

July 22, 1958

M. K. BUCHANAN

2,844,009

ICE TRAY

Filed Dec. 1, 1954

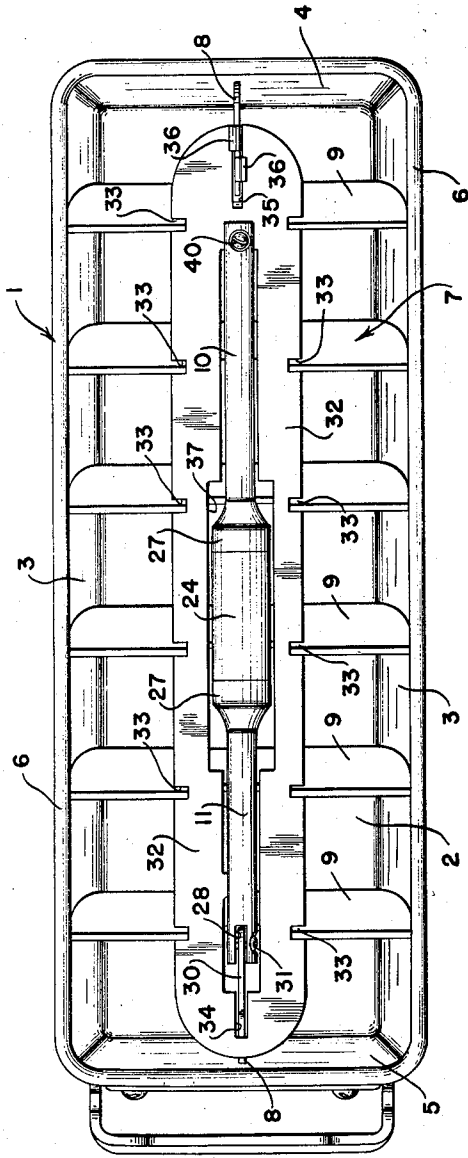

FIG. 1

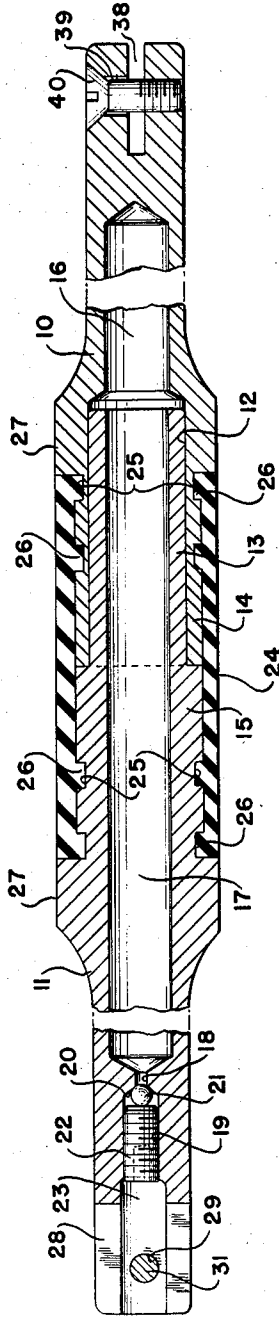

FIG. 2

INVENTOR.

Michael K. Buchanan

BY

Perme. Edwards, Minton, Barrows & Taylor

ATTORNEYS

1

2,844,009

ICE TRAY

Michael K. Buchanan, Norfolk, Va.

Application December 1, 1954, Serial No. 472,381

4 Claims. (Cl. 62—135)

This invention relates broadly to a fluid-tight connection between a pair of telescoping rods or tubes, and more specifically, in one of its applications, to an operating rod for an automatically releasable ice tray.

In one form of domestic ice tray, a pan of suitable size and shape is divided into compartments by means of a grid to produce ice cubes of a desired size. The grid consists of a longitudinal member and a plurality of transverse members. The transverse members are generally assembled with the longitudinal member to occupy an inclined position during the freezing of the cubes. Lever mechanism is arranged on the grid, generally with the lever pivoted to the longitudinal member, and connected by an intermediate member or transmitting member to the transverse members. The tray is filled with water, and placed in the freezing compartment of a refrigerator to form cubes. The bond between the cubes and the pan and grid is broken to remove the cubes from the tray by operating the lever to move the transverse members of the tray to a vertical or nearly vertical position.

In my prior Patent No. 2,599,972 granted June 10, 1952, I disclose an actuating member which will move the transverse members from their inclined position toward a vertical position when the water in the compartments is frozen to thus release the cubes. This actuating member consists of a telescoping unit containing water, or other liquid that expands on freezing. In the present invention I provide a device that may advantageously be employed as the actuating member of an ice tray of this type but which is actually capable of wider use, and can be employed in any construction in which a fluid or gas-tight connection is necessary between two telescoping members.

The construction preferably consists of two tubular members, one of which has an outside diameter at its end that may be snugly received in the end of the other member. The two members are also preferably of substantially the same outside diameter in portions adjacent the joint. A sleeve of rubber, or rubber-like material, surrounds the joint, and means are provided to anchor this sleeve to each of the members. When the members are retracted, the sleeve is normal, and when the members are extended the sleeve stretches to cover the joint. In either case it prevents leakage of the water or other fluid from the tubular members.

In the accompanying drawings I have shown one embodiment of the invention. In this showing:

Fig. 1 is a plan view of an ice tray showing the member applied; and

Fig. 2 is a longitudinal sectional view of the member.

Referring to Fig. 1 of the drawings, the reference numeral 1 designates generally a pan, which may be made of aluminum, metal, suitable plastic, or other material. The pan is provided with a bottom 2, side walls 3, a rear end wall 4 and a front end wall 5. The latter may be slightly inclined, as shown, to facilitate the release of the cubes. A bead 6 may be formed on the upper edge of the pan, as is conventional, to strengthen it. Within the pan I provide a grid 7, the

2

grid consisting of a centrally arranged upstanding, longitudinal member 8, and transverse members or fins 9. The grid members divide the interior of the pan into a plurality of compartments in which ice blocks or cubes are formed. The transverse members 9 are suitably secured to the longitudinal member 8 in such manner, as described in my prior patent, or by similar means, to permit them to assume the inclined position shown in Fig. 1 of the drawing during the freezing operation, and to be moved to a substantially vertical position to release the ice cubes, when the water in the pan is frozen.

The operating member consists of two tubular sections 10 and 11. Section 10 is provided with an enlarged bore 12 at the end where the joint is formed and section 11 is provided with a reduced end portion 13 of an external diameter to be snugly received in bore 12. Adjacent the joint the two sections are provided with portions 14 and 15, respectively, of substantially the same external diameter. As shown, portion 14 surrounds the end of the enlarged bore 12 of section 10, and portion 15 is adjacent the reduced end 13 of section 11. Thus, when the sections 10 and 11 are assembled, these portions 14 and 15 are brought together at the joint of the two sections.

The bore of section 10 extends from the enlarged portion 12 toward the other end of the section, as at 16, and terminates in a closed end or bottom. Bore 17 in section 11 extends toward the end remote from the joint and communicates with a reduced bore 18 which, in turn, communicates with a bore 19. Bore 19 is threaded and has a valve seat 20 formed at its inner end. A ball valve 21 is arranged on this seat and is retained in place by screw 22. Beyond bore 19 the section 11 is open to its end, as indicated at 23. Thus when the joint is used on an actuating member such as disclosed in my prior patent, and as herein illustrated, it is filled with water or other suitable fluid, the valve 21 placed at the bottom of bore 19, and the screw 22 tightened to hold the ball valve in place.

The joint between the two sections is surrounded by a fluid-tight sleeve 24 to prevent leakage of water in the specific embodiment herein disclosed, or of other fluid, when the invention is used as a fluid-tight seal in other applications. The sleeve is anchored to each of the sections to retain it in position over the joint. This may be done in various ways. Thus each of the portions 14 and 15 may be provided with one or more grooves 25 and the sleeve may be provided with ribs 26 which are received in these grooves. Beyond the ends of the sleeve the sections may be enlarged to external diameters corresponding to that of sleeve 24, as indicated at 27. This not only produces a construction of pleasing design and appearance, but these enlargements cooperate with the grooves 25 and ribs 26 to hold the sleeve in place. The sleeve may be of natural or synthetic rubber or other rubber-like material capable of stretching the necessary amount for the particular use to which the invention is being applied. I preferably employ a molded sleeve of Butyl rubber.

In the use of the extendible and contractible tube as the actuating member of an ice tray, one end, as illustrated, the section 11 is provided with a slot 28 which is vertically arranged when the parts are assembled. The end is provided with an opening 29 extending across the slot and tapped at one end. The longitudinal member 8 is provided with an ear 30 which is received in this slot. A screw 31 passes through opening 29 and an opening in ear 30 to secure this end of the actuating member to longitudinal member 8.

A transmitting member 32 is connected to the other end of the actuating member and to the transverse mem-

bers 9. As shown, the center portions of transverse members 9 are of reduced height and the transmitting member is arranged in this space. It is, however, of greater width than the reduced portion of the transverse members. The sides of the transmitting member which extend into the area occupied by the upper side portions of the transverse members are provided with slots 33 to receive the transverse members. When transmitting member 32 is moved toward the right in Fig. 1, the transverse members will be moved toward a vertical position. At the end adjacent the ear 30 the transmitting member is provided with a slot 34 through which the ear 30 passes. The other end is provided with an open-ended slot 35. A pair of ears 36, formed on longitudinal member 8, extend through this slot and are turned down on opposite sides to secure the parts to each other. The transmitting member is provided with a cut-out portion 37 which is of proper size to receive the actuating members.

Section 10 is also provided with a slot 38 that is horizontally arranged when the parts are assembled. An opening 39 extends across the slot, the lower half of the opening being tapped. The slot 38 receives the transmitting member adjacent the end of the cut-out 37 and the transmitting member is provided with an opening which is alined with opening 39 when the parts are assembled. A screw 40 passes through the openings to secure the parts to each other.

In assembling, the grid including the longitudinal member 8, transverse members 9 and transmitting member 32, are first assembled as in similar trays of the prior art, such as is shown, for instance, in Figs. 1 to 4 of my prior patent. The actuating member is then filled with water, valve 21 placed in bore 19 and screw 22 tightened in the bore to hold the ball valve in closed position. Screw 31 is then passed through the opening 29 and the opening in ear 30. Transmitting member 32 may be raised out of line with these openings to permit the screw to be inserted. The actuating member is then lowered into the cut-out 37. The actuating member is moved toward the left in Fig. 1 until end of section 10 clears the right end of the cut-out 37. It is then moved in the opposite direction to place the transmitting member in the slot 38 and aline opening 39 with the opening in the transmitting member. Screw 40 is then passed through these openings. The actuating member is arranged with its axis substantially in the plane of the transmitting member 32 and it is so dimensioned that when it is retracted, the transverse members 9 are in the inclined position shown in Fig. 1 of the drawings which, as heretofore stated, is conventional construction at the present time in domestic ice trays.

In operation, as one end of the actuating member is secured to longitudinal member 8 which is substantially of the same length as the length of the pan, and the other end secured to transmitting member 32, any extension of the actuating member will cause movement of the transmitting member toward the right in Fig. 1 of the drawing. When the pan is filled with water before placing it in a freezing unit, the water in the bore 16-17 is at substantially the same temperature as the water from which the ice cubes are to be formed. It is then placed in the freezing unit. As the contents of the tray are cooled, the liquid in the actuating member will probably be slightly higher than the temperature of the water in the compartments of the tray because of better heat transmission from the main body of water which is in contact with both walls of the pan and the walls of the grid. This compensates for the necessity of greater heat transfer from the compartments due to the greater dimensions of the bodies of water contained therein.

Thus the expansion due to freezing of the contained liquid and the consequent movement of transmitting member 32 moves the transverse members 9 of the grid to a vertical, or substantially vertical, position. This releases the cubes from the grid and pan and they may be

taken from the pan at any time when it is removed from the refrigerator. When the device is exposed to room temperature, the frozen or partly frozen liquid in the actuating member will liquefy and contract. The parts of the grid will then assume their original positions. The rubber sleeve 24 not only prevents leakage of liquid from the joint but it also aids in returning the grid parts to their normal positions when the material in the device liquefies and contracts in volume.

It will be apparent that, while the foregoing specification has been directed to an ice tray actuating member to give an illustration of the utility of the device, it has broader applications and can be used in any arrangement of a pair of telescoping, expanding members containing a fluid in which a fluid-tight joint is required between the members.

I claim:

1. In an ice tray comprising an open top pan, a grid arranged in the pan to divide it into a plurality of compartments, in which the grid comprises a longitudinal member and transverse members, and in which the transverse members are movable with respect to the longitudinal member to release the ice cubes from the tray, that improvement which comprises a pair of members, one end of one of said members being telescopically received in one end of the other, said members being provided with communicating bores, a body of liquid within the bores, one of said members being connected to the longitudinal member, the other being operatively connected to the transverse members, and a sleeve of rubber-like material surrounding the joint of the two members forming a fluid-tight seal and being sufficiently elastic to retain its position when the members are extended, the end portions of said members and the interior of said sleeve being provided with cooperating grooves and ribs to secure the sleeve to said members.

2. Apparatus in accordance with claim 1 in which a transmitting member is connected to the second telescoping member and to the transverse members to transmit movement from said member to the transverse members.

3. Apparatus in accordance with claim 1 in which the ends of the telescoping members adjacent the joint are provided with annular grooves, and the sleeve comprises a molded member having annular ribs received in the grooves.

4. An ice tray comprising an open top pan, a grid in the pan to divide it into a plurality of compartments, the grid comprising two sets of partition members relatively movable with respect to each other, that improvement which comprises a pair of members, one end of one of said members being telescopically received in one end of the other, said members being provided with communicating bores, a body of liquid within the bores, one of said members being operatively connected to one of said sets of partition members, the other being operatively connected to the other set of partition members, and a sleeve of rubber-like material surrounding the joint of the two members forming a fluid-tight seal and being sufficiently elastic to retain its position when the members are extended, the end portions of said members and the interior of said sleeve being provided with cooperating grooves and ribs to secure the sleeve to said members.

References Cited in the file of this patent

UNITED STATES PATENTS

1,844,488	Ward	Feb. 9, 1932
2,511,313	Yohe	June 13, 1950
2,576,591	Geyer	Nov. 27, 1951
2,599,972	Buchanan	June 10, 1952
2,776,545	Miller	Jan. 8, 1957

FOREIGN PATENTS

659,228	France	Feb. 4, 1929
---------	--------	--------------