



(12) **United States Design Patent**  
**Bacal**

(10) **Patent No.:** **US D1,007,186 S**  
(45) **Date of Patent:** **\*\* Dec. 12, 2023**

- (54) **ROLLER SHADE CASSETTE COVER**
- (71) Applicant: **Vertilux Limited**, Medley, FL (US)
- (72) Inventor: **Shike Bacal**, Miramar, FL (US)
- (73) Assignee: **VERTILUX LIMITED**, Medley, FL (US)
- (\*\*) Term: **15 Years**
- (21) Appl. No.: **29/854,699**
- (22) Filed: **Sep. 27, 2022**

3,454,073 A 7/1969 Man  
 3,524,491 A 8/1970 Olson  
 4,122,559 A 10/1978 Kelly  
 (Continued)

**FOREIGN PATENT DOCUMENTS**

AU 2009203048 10/2015  
 BG 6230-0011 9/2006  
 (Continued)

**OTHER PUBLICATIONS**

Bing Search, <http://www.quebanana.com/tienda/ver/herrajesmarino/145224>, Aug. 22, 2013.  
 (Continued)

**Related U.S. Application Data**

- (63) Continuation of application No. 29/755,755, filed on Oct. 22, 2020, now Pat. No. Des. 982,351, which is a continuation of application No. 29/699,110, filed on Jul. 23, 2019, now abandoned, which is a continuation-in-part of application No. 29/538,170, filed on Sep. 1, 2015, now Pat. No. Des. 878,103.
- (51) **LOC (14) Cl.** ..... **06-10**
- (52) **U.S. Cl.**  
USPC ..... **D6/580**
- (58) **Field of Classification Search**  
USPC ..... D6/575-577, 580-581; D13/155; D26/138  
CPC ..... A47H 1/14; A47H 1/142; A47H 1/144; A47H 11/04; E06B 9/323; E06B 9/388; E06B 9/42; E06B 9/46; E06B 9/48  
See application file for complete search history.

*Primary Examiner* — Kevin K Rudzinski  
*Assistant Examiner* — Clare Ann Gannon  
 (74) *Attorney, Agent, or Firm* — MALLOY & MALLOY, PL

(57) **CLAIM**

The ornamental design for a roller shade cassette cover, as shown and described.

**DESCRIPTION**

FIG. 1 is a front view illustrating my design for a roller shade cassette cover;  
 FIG. 2 is a front perspective view thereof;  
 FIG. 3 is a right side view thereof;  
 FIG. 4 is a left side view thereof;  
 FIG. 5 is a top view thereof;  
 FIG. 6 is a top perspective view thereof;  
 FIG. 7 is a rear view thereof;  
 FIG. 8 is a rear perspective view thereof;  
 FIG. 9 is a bottom view thereof; and,  
 FIG. 10 is a bottom perspective view thereof.  
 The broken lines depict portions of the claimed design that form no part of the claimed design.

(56) **References Cited**

**U.S. PATENT DOCUMENTS**

- 1,909,109 A 5/1933 Kopfstein
- 2,549,905 A 4/1951 Jablon
- 3,297,075 A 1/1967 Howell et al.
- 3,402,421 A 9/1968 Weber
- 3,417,519 A 12/1968 Hitter

**1 Claim, 7 Drawing Sheets**

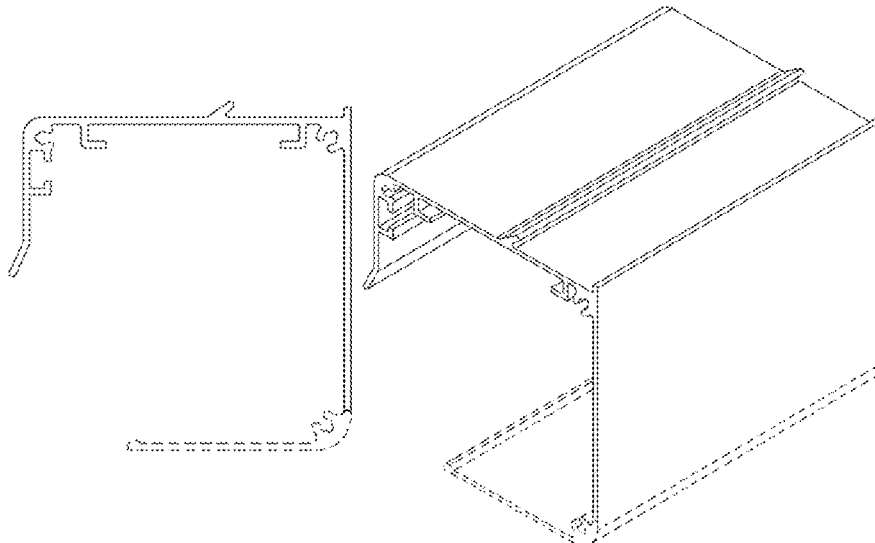

(56)

References Cited

U.S. PATENT DOCUMENTS

4,197,896	A	4/1980	Reichstadt	D652,568	S	1/2012	Trzesniowski	
D259,810	S	7/1981	Dallaire	8,136,569	B2	3/2012	Bohlen et al.	
D260,183	S	8/1981	Dallaire	8,220,520	B2	7/2012	Lukos	
4,393,915	A	7/1983	Olson	D675,050	S	1/2013	Garcia	
D271,055	S	10/1983	Cascone et al.	D680,357	S	4/2013	Wills et al.	
4,452,294	A	6/1984	Fukuchi	8,480,048	B2	7/2013	Krantz-Lilienthal	
D294,321	S	2/1988	Olofsson	8,528,623	B2	9/2013	Roberts	
4,840,216	A	6/1989	John	D691,398	S	10/2013	Chou	
4,935,988	A	6/1990	Ford et al.	D692,685	S	11/2013	Chou	
4,987,943	A	1/1991	Charest	D694,039	S	11/2013	Licciardi Di Stefano	
5,137,073	A	8/1992	Huang	D694,040	S	11/2013	Di Stefano	
5,232,039	A	8/1993	Shapiro et al.	8,584,317	B2	11/2013	Liebscher et al.	
5,259,687	A	11/1993	John	D695,042	S	12/2013	Licciardi Di Stefano	
5,271,687	A	12/1993	Holka et al.	D697,335	S	1/2014	Dekker et al.	
D345,498	S	3/1994	Fraser et al.	D699,976	S	2/2014	Chou	
5,296,964	A	3/1994	Shopp	D710,128	S	8/2014	Garcia	
5,330,821	A	7/1994	Lo	D715,629	S	10/2014	Grubb et al.	
D353,209	S	12/1994	Dallaire et al.	8,960,621	B2	2/2015	Wills	
D355,094	S	2/1995	Josephson	D727,659	S	4/2015	Kao	
D355,604	S	2/1995	De Baschmakoff	9,004,142	B2	4/2015	Marocco	
5,647,421	A	7/1997	Hoffman et al.	9,038,696	B2	5/2015	Lava et al.	
D382,651	S	8/1997	Colitto	9,060,636	B2	6/2015	Cannaverde	
D382,652	S	8/1997	Colitto	D740,589	S	10/2015	Ng	
5,803,144	A	9/1998	Ives	D742,138	S	11/2015	Chou	
D405,194	S	2/1999	Kenkel	9,175,512	B2	11/2015	Lu et al.	
5,924,255	A	7/1999	Vagedes	D753,933	S	4/2016	Ng	
5,975,186	A	11/1999	Day	D759,400	S	6/2016	Watkins	
5,983,972	A	11/1999	Chou	D762,398	S	8/2016	Ng	
D429,588	S	8/2000	Smederod	9,498,079	B2	11/2016	Sanchuk	
6,111,694	A	8/2000	Shopp	D775,939	S	1/2017	Ng	
6,173,825	B1	1/2001	Liu	D780,945	S	3/2017	Guillemi	
6,196,508	B1	3/2001	Nijs	D789,454	S	6/2017	Prisnie	
6,202,967	B1	3/2001	Fraczek	D791,580	S	7/2017	Chou	
D440,099	S	4/2001	Hortsen	D793,765	S	8/2017	Chou	
6,230,782	B1	5/2001	Reichert	D798,133	S	9/2017	Ng	
6,234,233	B1	5/2001	Biro	D808,684	S	1/2018	Santilli	
6,269,909	B1	8/2001	Grimes et al.	D808,685	S	1/2018	Raiti	
6,408,922	B2	6/2002	Desrochers	D813,570	S	3/2018	Santilli	
D468,453	S	1/2003	Schrader	9,976,346	B2	5/2018	Ng	
6,532,109	B1	3/2003	Shopp	D822,228	S	7/2018	Wang et al.	
D479,934	S	9/2003	Colson et al.	D828,052	S	9/2018	Bouroullec et al.	
6,666,251	B2	12/2003	Ikle	D833,175	S	11/2018	Miroshnichenko et al.	
D489,209	S	5/2004	Goldberg	D843,130	S	3/2019	Bacal	
6,739,373	B1	5/2004	Liu et al.	D843,131	S	3/2019	Chou	
D492,809	S	7/2004	Weitgasser	10,309,153	B2	6/2019	McPherson et al.	
D494,401	S	8/2004	Davies et al.	D854,192	S	7/2019	Rokvic	
6,817,399	B2	11/2004	Berman et al.	D854,855	S *	7/2019	Garcia Garcia	D6/580
6,817,402	B1	11/2004	Fraczek et al.	D854,856	S *	7/2019	Garcia Garcia	D6/580
6,978,821	B2	12/2005	Welfonder	10,407,905	B2	9/2019	Neal	
7,048,028	B2	5/2006	Wolfe et al.	D866,221	S *	11/2019	Chiquin	D6/579
D530,967	S	10/2006	Smith	10,544,621	B2	1/2020	Mocanu et al.	
7,141,164	B2	11/2006	Slack et al.	D878,103	S	3/2020	Bacal	
7,168,475	B2	1/2007	Colson et al.	10,619,412	B2	4/2020	Chen et al.	
D537,173	S	2/2007	Westphal et al.	D885,084	S	5/2020	Chiquin	
7,195,052	B2	3/2007	Nien et al.	10,648,230	B2	5/2020	Holt et al.	
D542,068	S	5/2007	Watkins et al.	D911,064	S	2/2021	Holt et al.	
7,210,513	B2	5/2007	Goldenberg et al.	D920,004	S *	5/2021	Chiquin	D6/580
D557,116	S	12/2007	Zakowski	D936,388	S *	11/2021	Schwandt	D6/580
7,353,857	B2	4/2008	Koop	D938,190	S *	12/2021	Tan	D6/575
7,367,536	B1	5/2008	Anderson et al.	D940,477	S	1/2022	Chiquin	
7,380,582	B1	6/2008	Anderson et al.	11,332,974	B2	5/2022	Chiquin	
D573,267	S	7/2008	Brinton et al.	D954,467	S	6/2022	Chiquin	
D577,138	S	9/2008	Kitagawa et al.	D955,140	S *	6/2022	Garcia Garcia	D6/575
D591,442	S	4/2009	Ford et al.	D955,141	S *	6/2022	Garcia Garcia	D6/575
D596,435	S	7/2009	Wills	D958,563	S *	7/2022	Bouroullec	D6/575
D599,051	S	8/2009	Wu et al.	D970,254	S	11/2022	Chiquin	
D604,885	S	11/2009	Ford et al.	D982,351	S *	4/2023	Bacal	D6/580
7,614,439	B2	11/2009	Lukos	D987,886	S *	5/2023	Wang	D26/138
D616,567	S	5/2010	Desrosiers et al.	D994,389	S *	8/2023	Bouroullec	D6/575
D616,568	S	5/2010	Desrosiers et al.	D996,372	S *	8/2023	Hu	D8/356
7,770,625	B2	8/2010	Lukos	2003/0178276	A1	9/2003	Fraczek et al.	
D628,715	S	12/2010	Gosling et al.	2004/0129391	A1	7/2004	Gottschall et al.	
D634,573	S	3/2011	Risher	2004/0182522	A1	9/2004	Strand et al.	
7,921,602	B2	4/2011	Ohanesian	2005/0247413	A1	11/2005	Nien et al.	
7,997,041	B2	8/2011	Slack et al.	2005/0269044	A1	12/2005	Nien	
				2006/0000559	A1	1/2006	Bohlen	
				2006/0049325	A1	3/2006	Jung	
				2006/0086874	A1	4/2006	Habel et al.	
				2006/0113046	A1	6/2006	Prince et al.	

(56)

## References Cited

## U.S. PATENT DOCUMENTS

2006/0243402	A1	11/2006	Chang
2007/0169900	A1	7/2007	Chen et al.
2007/0221344	A1	9/2007	Beach et al.
2007/0284051	A1	12/2007	Grimes et al.
2008/0035281	A1	2/2008	Kirby
2008/0121353	A1	5/2008	Detmer et al.
2008/0245489	A1	10/2008	Chuang et al.
2009/0229767	A1	9/2009	Mullet et al.
2009/0250177	A1	10/2009	Byeon
2009/0258752	A1	10/2009	Bohlen et al.
2010/0101741	A1	4/2010	Koop
2010/0175838	A1	7/2010	Faller et al.
2010/0300631	A1	12/2010	Sullivan
2011/0006176	A1	1/2011	Krantz-Lilienthal
2011/0049071	A1	3/2011	Hart et al.
2011/0114809	A1	5/2011	Ng
2012/0012262	A1	1/2012	Santoro et al.
2012/0031572	A1	2/2012	Ng et al.
2012/0061034	A1	3/2012	Ng
2012/0097346	A1	4/2012	Ng
2012/0255686	A1	10/2012	Huang
2013/0048229	A1	2/2013	Dwarka
2013/0068405	A1	3/2013	Lava et al.
2013/0098563	A1	4/2013	Jang
2013/0176743	A1	7/2013	Pfund et al.
2014/0009519	A1	1/2014	Kumagai et al.
2014/0048218	A1	2/2014	Ng
2014/0166218	A1	6/2014	Ng
2014/0251558	A1	9/2014	Chou
2014/0262076	A1	9/2014	Mullet et al.
2014/0305602	A1	10/2014	Kirby et al.
2014/0352897	A1	12/2014	Mullet et al.
2015/0027059	A1	1/2015	Lu et al.
2015/0047792	A1	2/2015	Lukosiunas et al.
2015/0075726	A1	3/2015	Byun
2015/0240851	A1	10/2015	Giacometti et al.
2015/0275571	A1	10/2015	Guhl
2015/0292261	A1	10/2015	Chou
2015/0292262	A1	10/2015	Miller et al.
2015/0297014	A1	10/2015	Cannaverde
2015/0368970	A1	12/2015	Chambers et al.
2016/0032646	A1	2/2016	Fleischman
2016/0051074	A1	2/2016	Chou
2016/0090779	A1	3/2016	Nurre et al.
2016/0130869	A1	5/2016	Cheng
2016/0298375	A1	10/2016	Wagner et al.
2016/0326800	A1	11/2016	Marocco
2016/0340972	A1	11/2016	Chou
2017/0009519	A1	1/2017	Marocco
2017/0079459	A1	3/2017	Filko
2017/0114593	A1	4/2017	Hebeisen et al.
2018/0087319	A1	3/2018	McPherson et al.
2018/0202157	A1	7/2018	Neal
2018/0310745	A1	11/2018	Giri et al.
2018/0313147	A1	11/2018	Krantz-Lilienthal et al.
2019/0186198	A1	6/2019	Kirby
2019/0249488	A1	8/2019	Campagna
2019/0264499	A1	8/2019	McNeill et al.
2019/0352963	A1	11/2019	Jang
2020/0052515	A1	2/2020	Nien et al.
2020/0095825	A1	3/2020	Chen et al.
2020/0131846	A1	4/2020	Hebeisen et al.
2020/0185965	A1	6/2020	Poirier et al.
2020/0208464	A1	7/2020	Guest et al.
2020/0284093	A1	9/2020	Dahlgren et al.
2020/0355026	A1	11/2020	Liu
2021/0131179	A1	5/2021	Campagna et al.
2021/0222490	A1	7/2021	Campagna et al.
2021/0310299	A1	10/2021	Chiquin
2022/0003041	A1	1/2022	Graybar et al.

## FOREIGN PATENT DOCUMENTS

BG	6230-0016	9/2006
BR	3020120013798	2/2013
BR	3020120056900	3/2016
CN	2012300548304	3/2013
CN	2012303568969	4/2013
CO	07051520	5/2007
CO	282	7/2012
EM	000113899-0003	4/2003
EM	000275839-0002	12/2004
EM	000279633-0001	1/2005
EM	000518923-0001	4/2006
EM	000795752-0001	9/2007
EM	001084370-0013	2/2009
EM	001102875-0002	3/2009
EM	0013369940001	7/2012
EM	003342013-0012	8/2016
GB	2052622	12/1995
GB	2391577	2/2004
MX	38640	5/2013
PE	002031-2018	1/2019
WO	WOD068016-0004	6/2006
WO	WOD086931-0004	6/2015

## OTHER PUBLICATIONS

Rollashade, Rollashade Contract Series, Feb. 5, 2018.  
 Rolleaseacmeda, System Quick Reference Guide; [https://www.rolleaseacmeda.com/docs/default-source/default-document-library/edge-side-channels\\_qrg\\_us\\_v1-0.pdf?sfvrsn=0&sfvrsn=0](https://www.rolleaseacmeda.com/docs/default-source/default-document-library/edge-side-channels_qrg_us_v1-0.pdf?sfvrsn=0&sfvrsn=0), Feb. 5, 2018.

\* cited by examiner



FIG. 1

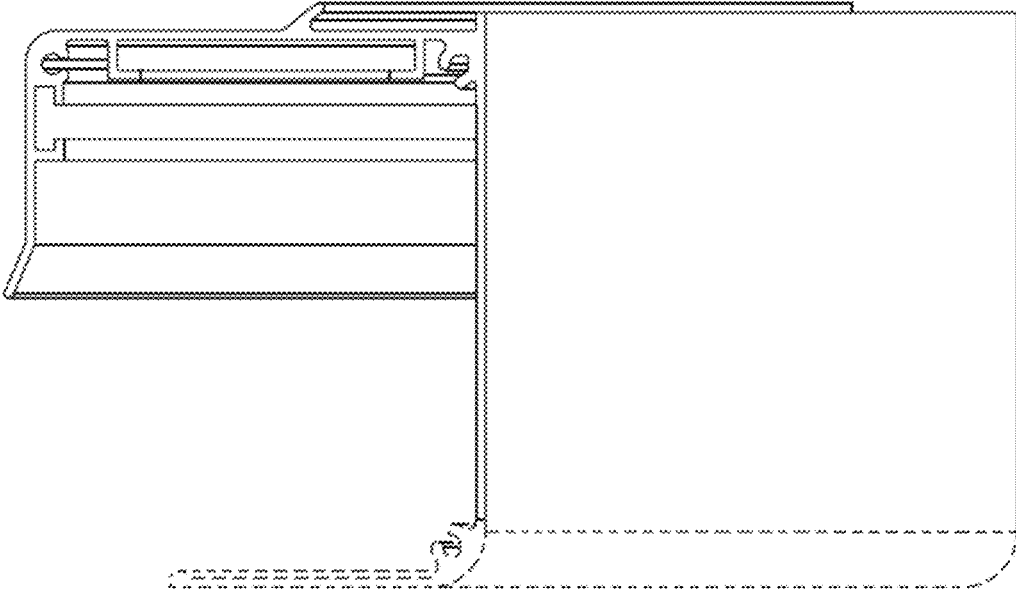

FIG. 2

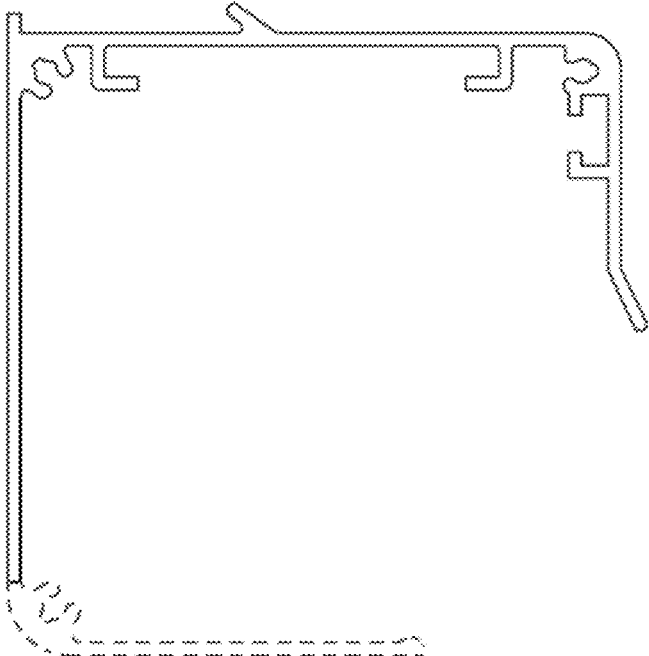

FIG. 3

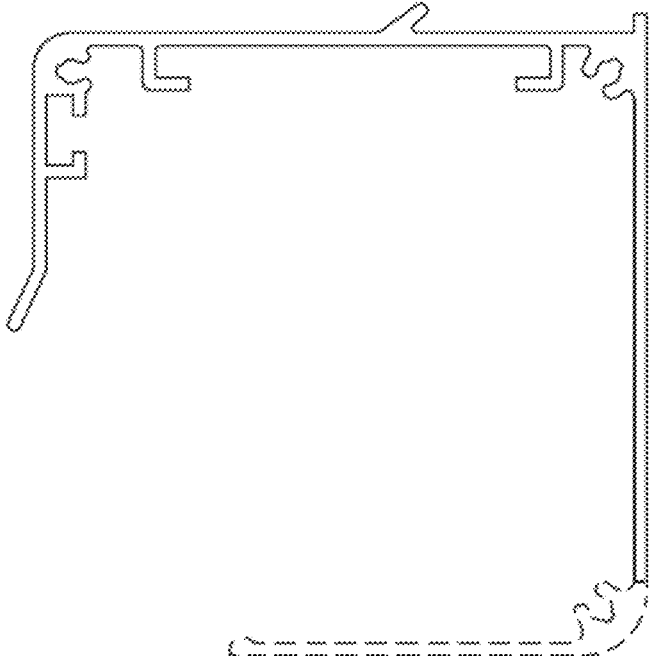

FIG. 4

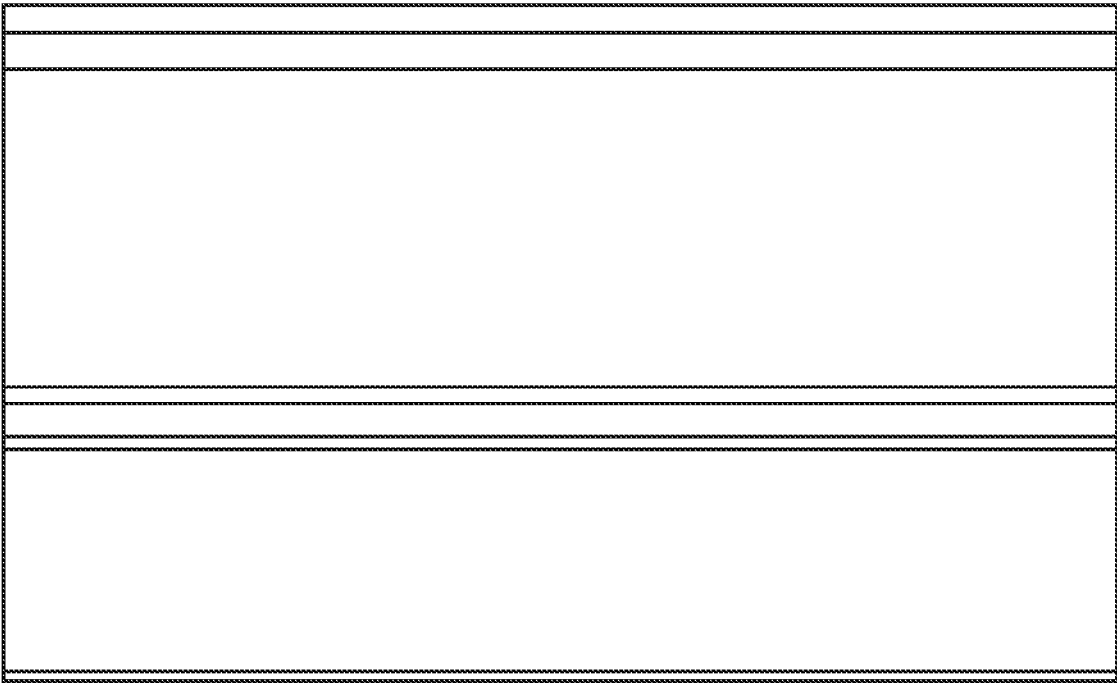

FIG. 5

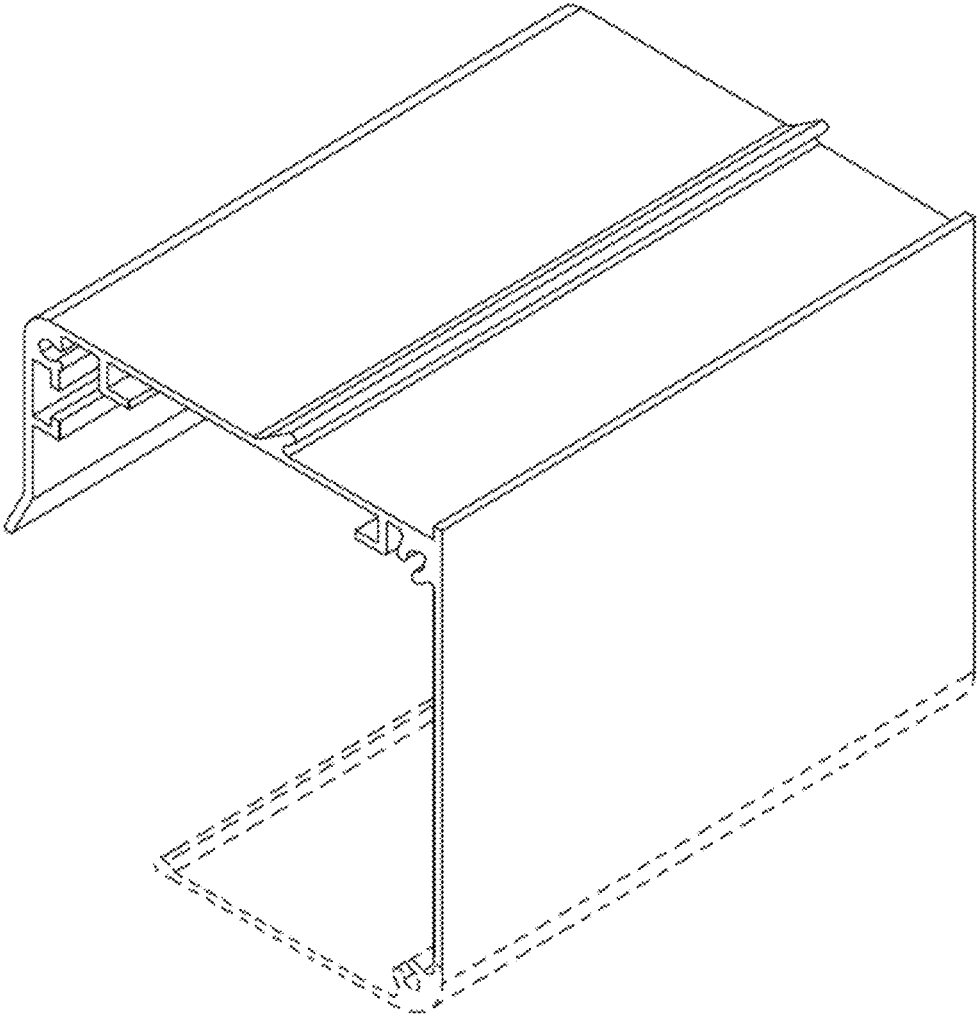

FIG. 6

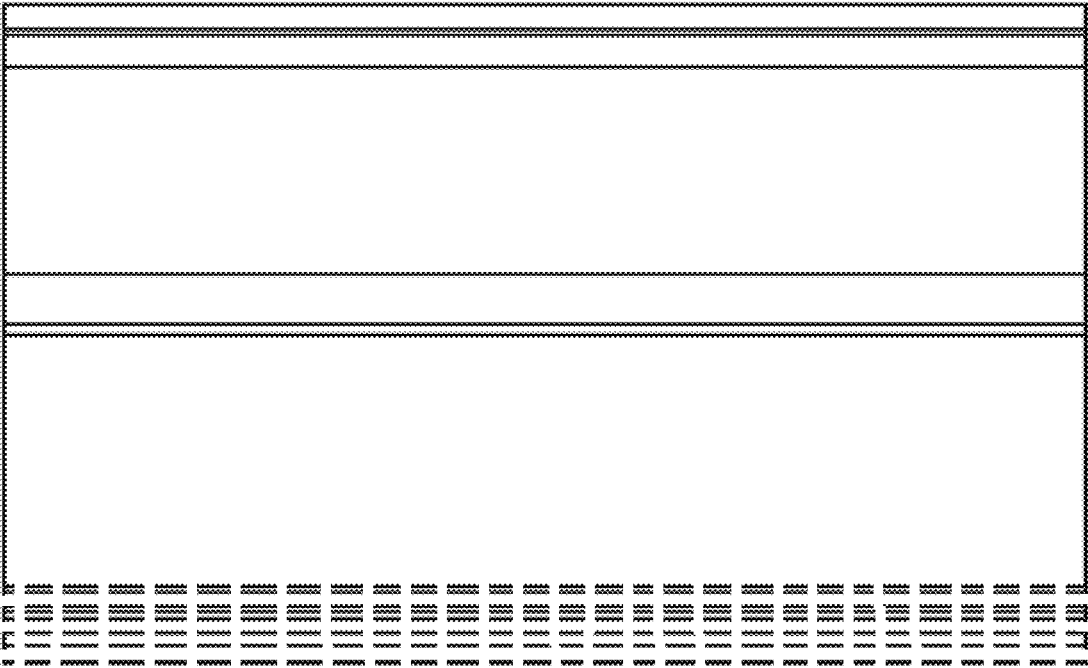

FIG. 7

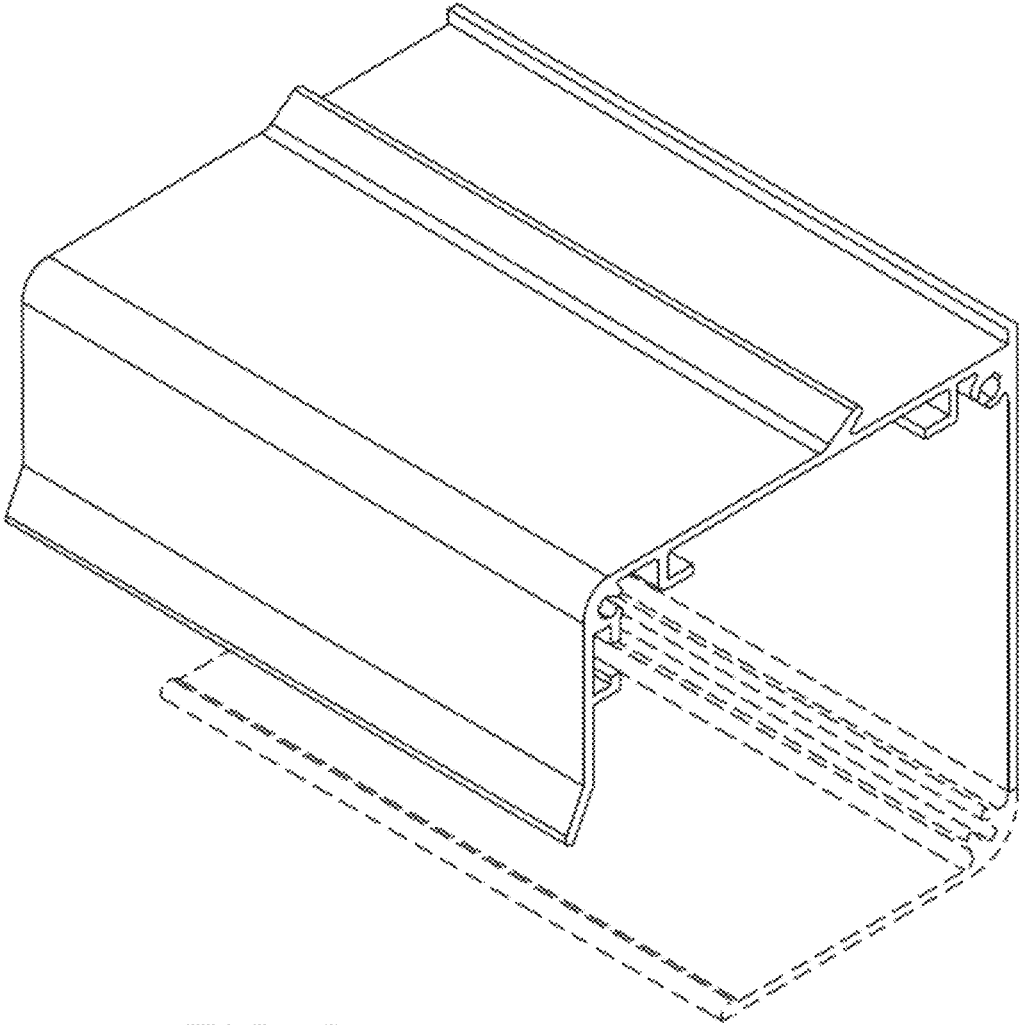

FIG. 8

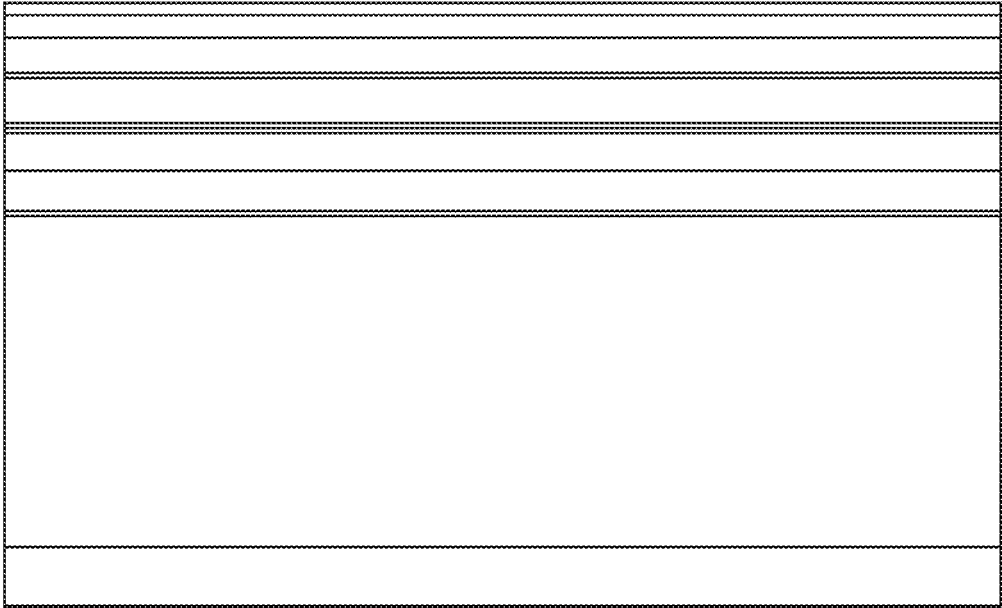

FIG. 9

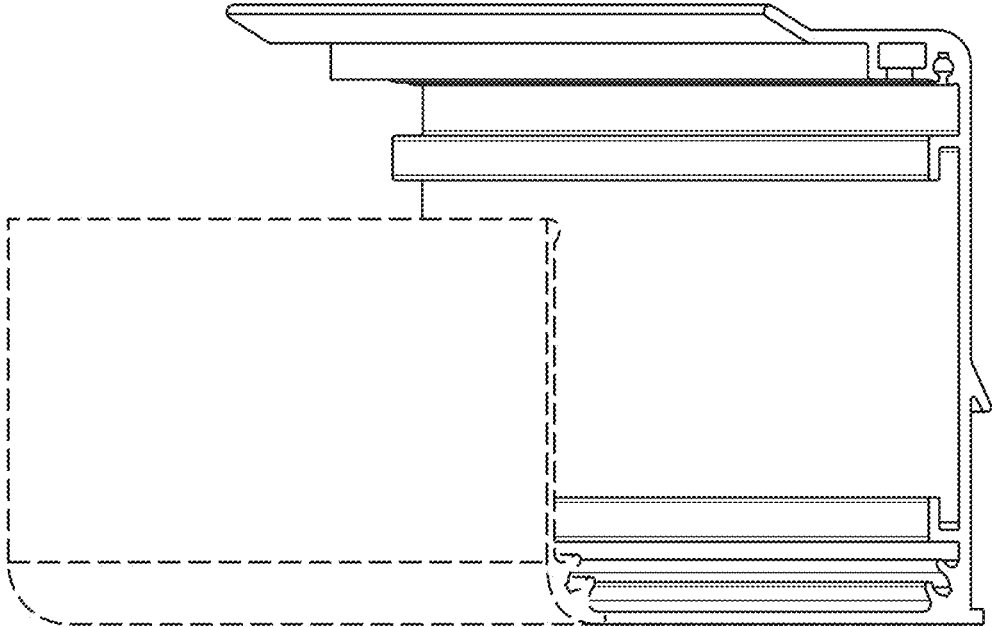

FIG. 10