

(12) STANDARD PATENT
(19) AUSTRALIAN PATENT OFFICE

(11) Application No. **AU 2006209823 B2**

(54) Title
Method and apparatus for harvesting and picking up sod

(51) International Patent Classification(s)
A01G 1/12 (2006.01)

(21) Application No: **2006209823** (22) Date of Filing: **2006.02.01**

(87) WIPO No: **WO06/081654**

(30) Priority Data

(31) Number	(32) Date	(33) Country
60/649,639	2005.02.04	US
60/663,246	2005.03.21	US
60/758,195	2006.01.12	US
60/715,135	2005.09.09	US

(43) Publication Date: **2006.08.10**

(44) Accepted Journal Date: **2011.11.24**

(71) Applicant(s)
1045929 Ontario Limited

(72) Inventor(s)
Milwain, Robert;Brouwer, Gerardus J.

(74) Agent / Attorney
Freehills Patent & Trade Mark Attorneys, Level 43 101 Collins Street, Melbourne, VIC, 3000

(56) Related Art
CA 2187603 A1
US 4294316 A
US 2005/0000704A1
US 5857527 A
US 3935904 A

(12) INTERNATIONAL APPLICATION PUBLISHED UNDER THE PATENT COOPERATION TREATY (PCT)

(19) World Intellectual Property Organization
International Bureau



(43) International Publication Date
10 August 2006 (10.08.2006)

PCT

(10) International Publication Number
WO 2006/081654 A1

- (51) International Patent Classification:
A01G 1/12 (2006.01)
- (21) International Application Number:
PCT/CA2006/000125
- (22) International Filing Date: 1 February 2006 (01.02.2006)
- (25) Filing Language: English
- (26) Publication Language: English
- (30) Priority Data:
60/649,639 4 February 2005 (04.02.2005) US
60/663,246 21 March 2005 (21.03.2005) US
60/715,135 9 September 2005 (09.09.2005) US
60/758,195 12 January 2006 (12.01.2006) US
- (71) Applicant (for all designated States except US): **1045929 ONTARIO LIMITED** [CA/CA]; 23965 Warden Avenue, Keswick, Ontario L4P 3E9 (CA).
- (72) Inventors; and
- (75) Inventors/Applicants (for US only): **BROUWER, Gerardus, J.** [CA/CA]; 23965 Warden Avenue, Keswick, Ontario L4P 3E9 (CA). **MILWAIN, Robert** [CA/CA]; 5 Patricia Place, Keswick, Ontario L4P 3T9 (CA).
- (74) Agent: **Bereskin & Parr**; 40 King Street West, 40th Floor, Toronto, Ontario M5H 3Y2 (CA).
- (81) Designated States (unless otherwise indicated, for every kind of national protection available): AE, AG, AL, AM, AT, AU, AZ, BA, BB, BG, BR, BW, BY, BZ, CA, CH, CN, CO, CR, CU, CZ, DE, DK, DM, DZ, EC, EE, EG, ES, FI, GB, GD, GE, GH, GM, HR, HU, ID, IL, IN, IS, JP, KE, KG, KM, KN, KP, KR, KZ, LC, LK, LR, LS, LT, LU, LV, LY, MA, MD, MG, MK, MN, MW, MX, MZ, NA, NG, NI, NO, NZ, OM, PG, PH, PL, PT, RO, RU, SC, SD, SE, SG, SK, SL, SM, SY, TJ, TM, TN, TR, TT, TZ, UA, UG, US, UZ, VC, VN, YU, ZA, ZM, ZW.
- (84) Designated States (unless otherwise indicated, for every kind of regional protection available): ARIPO (BW, GH, GM, KE, LS, MW, MZ, NA, SD, SL, SZ, TZ, UG, ZM, ZW), Eurasian (AM, AZ, BY, KG, KZ, MD, RU, TJ, TM), European (AT, BE, BG, CH, CY, CZ, DE, DK, EE, ES, FI, FR, GB, GR, HU, IE, IS, IT, LT, LU, LV, MC, NL, PL, PT, RO, SE, SI, SK, TR), OAPI (BF, BJ, CF, CG, CI, CM, GA, GN, GQ, GW, ML, MR, NE, SN, TD, TG).
- Published:
— with international search report
- For two-letter codes and other abbreviations, refer to the "Guidance Notes on Codes and Abbreviations" appearing at the beginning of each regular issue of the PCT Gazette.

(54) Title: METHOD AND APPARATUS FOR HARVESTING AND PICKING UP SOD

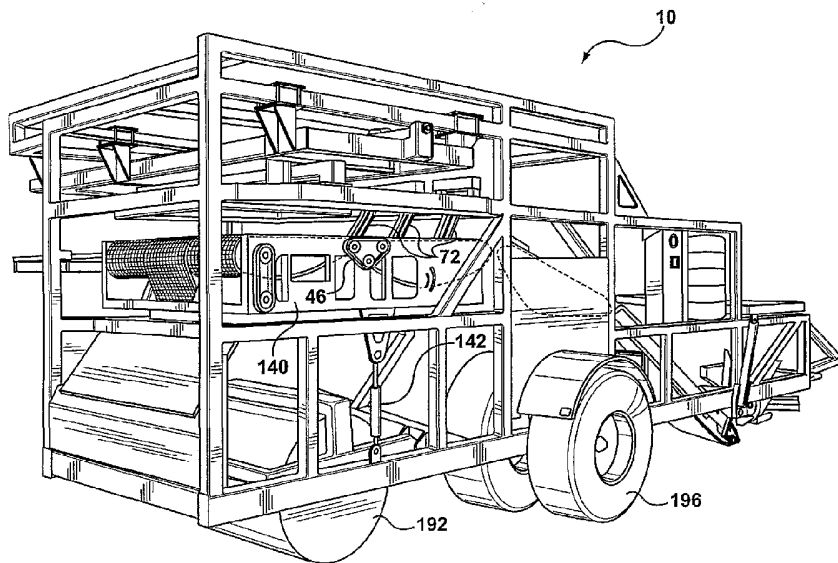

(57) Abstract: A sod harvester cuts several side-by-side strips of sod, preferably of total width equal to the width of a pallet, and directs the strips up three sets of conveyors arranged in sequence. The first conveyor set runs at or near ground speed; the second conveyor set runs at about double ground speed, and the third conveyor set runs at about triple ground speed. This creates a spatial and time gap between the trailing edges of a set of sod strips on the third conveyor and the leading edges of the next set of sod strips behind them on the second conveyor. The time gap is sufficient to stop the sod strips on the third conveyor and then pick them up and stack them on a pallet.

WO 2006/081654 A1

- 1 -

Title: **METHOD AND APPARATUS FOR HARVESTING
AND PICKING UP SOD**

Field of the invention

[0001] This invention relates to a sod harvester which, after harvesting sod, can pick up the cut sod and stack it, and to methods relating to sod harvesting.

5 **Background of the invention**

[0002] Sod harvesters for cutting a strip of sod from the ground and for stacking the sod as a set of slabs on a receiving surface (typically a pallet) have existed for many years. However, prior harvesters which have included a mechanism for automatically stacking slabs of sod on a pallet have been
10 extremely complex and costly. One problem has been that since the strip of sod is normally cut and delivered continuously from the ground, a buffer storage must be provided on the sod harvester to receive sod which continues to be delivered from the cutting knife at the same time when sod which has previously been cut is to be picked up and stacked or moved to another
15 location. The provision of buffer storage for the sod until it can be picked up has in the past added to the size, cost and complexity of the harvester.

Brief summary of the invention

[0003] It is therefore an object of the present invention, in one of its aspects, to provide a method and apparatus for handling sod in a harvester
20 which cuts a continuous strip of sod, such that the complexity of providing a separate buffer storage for newly cut sod while previously cut sod is being picked up, is reduced. In one aspect the present invention provides a sod harvester adapted for travel along a path of travel and comprising:

- a) a sod cutting knife for cutting pieces of sod from the
25 ground, each piece having a leading edge and a trailing edge,
- b) a conveyor mechanism for carrying sod away from said cutting knife to a first location,

2006209823 11 Oct 2011

c) a sod pick-up mechanism for picking up sod from said first location and for moving such sod to a second location and for then returning to said first location to again pick up sod at said first location,

5 d) said conveyor mechanism including a plurality of conveyors in sequence including a first conveyor for receiving a sod piece from said cutting knife and a second conveyor for receiving and accelerating said sod piece toward said first location to create a time period between the passage of the trailing edge of one sod piece and the arrival of the leading edge of the following sod piece,

10 e) said conveyor mechanism further including a mechanism for supporting a said sod piece in a stopped condition at said first location, while a following sod piece is moving towards said first location,

15 f) said time period being sufficient for a said sod piece to assume said stopped condition at said first location and for said sod pick-up mechanism to pick up and remove the stopped sod piece from said first location before the following sod piece arrives at said first location.

[0003a] In another aspect, the invention provides a sod harvester adapted for travel along a path of travel and further adapted to be mounted on the side of a tractor, said tractor having rear wheels having an axis, said sod harvester comprising a sod cutting knife for cutting pieces of sod from the ground, a conveyor mechanism for
20 carrying sod rearwardly from said cutting knife, and a support wheel located behind said cutting knife to support a portion of the weight of said harvester, said support wheel having an axis aligned in a front to rear direction with said axis of said tractor rear wheels, said support wheel including a suspension mounting said support wheel to said harvester, said suspension including a piston and cylinder connected to said harvester
25 and acting to control the proportion of the weight of the harvester placed on said support wheel.

[0003b] In a further aspect, the invention provides a method of harvesting and handling sod comprising:

2006209823 11 Oct 2011

a) cutting an elongated sod slab, and

b) cutting said sod slab into two sod sections, but leaving uncut at least one small sod connection between said two sod sections, thereby to tie together said sod sections in a stack containing said sod sections.

5 [0004] In another aspect the present invention provides a method of harvesting sod comprising:

a) continuously cutting pieces of sod, each piece having a leading edge and a trailing edge,

b) conveying said pieces of sod sequentially to a first location,

10 c) while performing said conveying, accelerating each sod piece away from the sod piece behind it to create a time interval between the passage of the trailing edge of one sod piece and the leading edge of the next sod piece,

d) stopping a sod piece at said first location and while said sod piece is stopped, picking up said sod piece and then moving such sod piece to a second
15 location,

e) the steps of stopping and picking up said sod piece being performed in said time interval.

[0004a] The invention also provides, in a still further aspect, a method of harvesting and handling sod comprising:

20 a) cutting an elongated sod slab,

b) moving said sod slab onto a conveyor using a sod carrier and stopping said sod slab on said conveyor,

c) cross-cutting said sod slab into at least two pieces while said sod slab is stopped on said conveyor, and

25 d) picking up said pieces of said sod slab for deposit of said pieces on a sod

stack

wherein said sod carrier includes at least first and second side-by-side and separately operable sod pick-up mechanisms, said moving step further comprising:

5 (i) positioning said sod carrier over said conveyor so that said first pick-up mechanism is over said sod slab,

(ii) picking up said sod slab with said first sod pick-up mechanism,

(iii) moving a new sod slab onto said conveyor,

(iv) moving said sod carrier to position said second sod pick-up mechanism over said new sod slab on said conveyor,

10 (v) picking up said new sod slab with said second sod pick-up mechanism, and moving said sod carrier to deposit sod picked up thereby onto a sod stack.

2006209823 11 Oct 2011

[0005] Further objects and aspects of the invention will appear from the accompanying disclosure, taken together with the accompanying drawings.

Brief description of the drawings

[0006] In the drawings:

5 [0007] Fig. 1 is a perspective view of a sod harvester according to the invention;

[0008] Fig. 2 is a diagrammatic side view of a portion of the sod harvester of Fig. 1;

10 [0009] Fig. 3 is a top view of sod cutting knives and rollers for the Fig. 1 harvester;

[0010] Fig. 4A is a perspective view of conveyors for the Fig. 1 sod harvester, with sod advancing up the first set of conveyors;

[0011] Fig. 4B is a perspective view of the middle conveyor from the third set of conveyors of the Fig. 1 sod harvester;

15 [0012] Fig. 4C is a perspective view similar to that of Fig. 4A but showing sod located on the first and second sets of conveyors;

[0013] Fig. 4D is a view similar to that of Fig. 4C but showing sod advancing up the first and second sets of conveyors and with sod also located on the third set of conveyors;

20 [0014] Fig. 5 is a diagrammatic view of a sensor for the Fig. 1 sod harvester;

[0015] Fig. 6 is a simplified perspective view showing a gantry and a sod carrier for the Fig. 1 sod harvester;

[0016] Fig. 7 is a top view of the gantry and sod carrier of Fig. 6;

25 [0017] Fig. 8A is another perspective view of the gantry and sod carrier of the Fig. 1 harvester, in place over the third conveyor set and over a pallet;

[0018] Fig. 8B is a view similar to that of Fig. 8A but showing sod located on the pallet, having been deposited there by the sod carrier;

- 4 -

- [0019]** Fig. 9A is a top view showing portions of the gantry and sod carrier of Fig. 6;
- [0020]** Fig. 9B is a top view similar to that of Fig. 9A but showing the sod carrier located over the pallet and rotated 90° from the position of Fig. 9A;
- 5 **[0021]** Fig. 9C is a view similar to that of Fig. 9A but showing sod on the pallet in the position in which it was deposited by the sod carrier from the Fig. 9B orientation;
- [0022]** Fig. 10 is a diagrammatic view of sensors, a computer and a hydraulic circuit for the Fig. 1 sod harvester;
- 10 **[0023]** Fig. 11 is a perspective view of a portion of a clamp on the sod carrier of the Fig. 1 harvester;
- [0024]** Fig. 12 is a front view of a pallet containing layers of sod placed by the Fig. 1 harvester;
- [0025]** Fig. 13 is a rear perspective view of a portion of the Fig. 1 sod
15 harvester, showing details of the forklift and pallet;
- [0026]** Fig. 14 is a perspective view showing further detail of the forklift of the Fig. 1 sod harvester;
- [0027]** Fig. 15 is a simplified perspective view showing portions of the forklift of the Fig. 1 sod harvester with an electric eye level adjusting
20 mechanism;
- [0028]** Fig. 16 is a side view showing a rear roller arrangement for the Fig. 1 sod harvester;
- [0029]** Fig. 17 is a diagrammatic view of another embodiment of the harvester according to the invention, mounted on the side of a tractor;
- 25 **[0030]** Fig. 18 is a side view of the tractor and harvester of Fig. 17;
- [0031]** Fig. 19 is a top view of a sod layer stacked on a pallet according to an aspect of the invention;
- [0032]** Fig. 20 is an edge view of the sod stack of Fig. 19;

- [0033]** Fig. 21 is a perspective view of the sod stack of Figs. 19 and 20;
- [0034]** Fig. 22 is a top view of another set of sod layers stacked on a pallet;
- [0035]** Fig. 23 is an edge view of the sod stack of Fig. 22;
- 5 **[0036]** Fig. 24 is a perspective view of the sod stack of Figs. 22 and 23;
- [0037]** Fig. 25 is a top view showing sod on a pallet on forks having a scissors connection to the forklift mast;
- [0038]** Fig. 26 is a side view of the arrangement of Fig. 25;
- [0039]** Fig. 27 is a top view similar to that of Fig. 25 but with the
10 scissors extended;
- [0040]** Fig. 28 is a side view of the Fig. 27 arrangement;
- [0041]** Fig. 29 is a perspective view of the Fig. 25 arrangement;
- [0042]** Fig. 30 is a perspective view of a sod slab and knives for cutting the sod slab into a number of pieces;
- 15 **[0043]** Fig. 31A is a top view of a pallet injector for supplying a pallet to the forklift of the Fig. 1 harvester, and also showing the forklift, in idle condition;
- [0044]** Fig. 31B is a side view of the Fig. 31A arrangement;
- [0045]** Fig. 31C is a perspective view of the Fig. 31A arrangement;
- 20 **[0046]** Fig. 32A is a top view similar to Fig. 31A and showing the pallet dispenser pulled back;
- [0047]** Fig. 32B is a side view of the Fig. 31A arrangement;
- [0048]** Fig. 32C is a perspective view of the Fig. 32A arrangement;
- [0049]** Fig. 33A is a top view of the Fig. 31A arrangement, with the
25 pallet dispenser having pushed a pallet over the forks;
- [0050]** Fig. 33B is a side view of the Fig. 33A arrangement;
- [0051]** Fig. 33C is a perspective view of the Fig. 33A arrangement;

- 6 -

- [0052]** Fig. 34A is a top view of the Fig. 31A arrangement, with a pallet supported by the pallet injector over the forks and sod stacked thereon;
- [0053]** Fig. 34B is a side view of the Fig. 34A arrangement;
- [0054]** Fig. 34C is a perspective view of the Fig. 34A arrangement;
- 5 **[0055]** Fig. 35A is a top view of the Fig. 31A arrangement, with the pallet now supported by the forklift forks;
- [0056]** Fig. 35B is a side view of the Fig. 35A arrangement;
- [0057]** Fig. 35C is a perspective view of the Fig. 35A arrangement;
- [0058]** Fig. 36A is a top view of the Fig. 31A arrangement, with the
10 pallet dispenser pulled back and the pallet on the forks loaded with sod and in a lowered position;
- [0059]** Fig. 36B is a side view of the Fig. 36A arrangement;
- [0060]** Fig. 36C is a perspective view of the Fig. 36A arrangement;
- [0061]** Fig. 37A is a top view of the Fig. 31A arrangement, with the
15 pallet injector having pushed a new pallet over the forks for loading, and with a loaded pallet still on the forks;
- [0062]** Fig. 37B is a side view of the Fig. 37A arrangement;
- [0063]** Fig. 37C is a perspective view of the Fig. 37A arrangement;
- [0064]** Fig. 38 is a plan view of cut slabs of sod on a pallet, and
20 showing each layer rotated by a few degrees with respect to the layer below it;
- [0065]** Fig. 39 is a perspective view of the sod layers of Fig. 38;
- [0066]** Fig. 40 is an end view of a piling cavity for stacking sod slabs, dimensioned to produce curled up edges for the sod and to produce overlap
25 in successive layers of sod;
- [0067]** Fig. 41 is a perspective view of a stack of sod on a pallet and having curled up edges;

- 7 -

- [0068]** Fig. 42A is an end view of a pallet having a concave upper surface;
- [0069]** Fig. 42B is a perspective view of the Fig. 42A pallet;
- [0070]** Fig. 43A is an end view of a modified pallet having a concave upper surface;
- 5 **[0071]** Fig. 43B is a perspective view of the Fig. 43A pallet;
- [0072]** Fig. 44A is an end view of a further modified pallet having a concave upper surface;
- [0073]** Fig. 44B is a perspective view of the Fig. 44A pallet;
- 10 **[0074]** Fig. 45A is an end view of a still further modified pallet having a concave upper surface;
- [0075]** Fig. 45B is a perspective view of the Fig. 45A pallet;
- [0076]** Fig. 46A is an end view of yet another modified pallet having a concave upper surface;
- 15 **[0077]** Fig. 46B is a perspective view of the Fig. 46A pallet;
- [0078]** Fig. 47A is an end view of another modified pallet having a concave upper surface;
- [0079]** Fig. 47B is a perspective view of the Fig. 47A pallet;
- [0080]** Fig. 48 is an end view of the Fig. 47A, Fig. 47B pallet with sod stacked thereon;
- 20 **[0081]** Fig. 49 is a perspective view of an elongated sod slab and a cutting knife for partially severing two portions of the sod slab;
- [0082]** Figs. 50A to 50E inclusive are side views of different versions of a cross-cut knife for partially severing an elongated sod slab into two partially connected sod slabs;
- 25

[0083] Fig. 51 is a top diagrammatic view of a portion of a harvester and showing three sod cutting heads mounted on the harvester for powered sideways movement of two of the heads;

[0084] Fig. 52 is a perspective view of the front of the harvester
5 showing a set of three cross-cut knives, each separately pivoted, for cross-cutting a wide strip of sod;

[0085] Fig. 53 is a front view of the cross-cut knives of Fig. 52;

[0086] Fig. 54 is a diagrammatic side view of third set conveyors and the sod pick-up mechanism illustrating another aspect of the invention;

10 [0087] Fig. 55 is a diagrammatic perspective view of the apparatus of Fig. 54; and

[0088] Fig. 56 is a diagrammatic perspective view of a modification of the apparatus of Fig. 55.

Detailed description of preferred embodiment

15 [0089] Reference is first made to Fig. 1, which shows a simplified diagrammatic view of a sod harvester **10** according to the invention. The sod harvester **10** is intended to be pulled by a towing vehicle, e.g. a tractor (not shown), but it will be appreciated that a sod harvester according to the invention can be self-propelled, or it can be mounted directly on the side of a
20 tractor, as is well known in the field.

[0090] The harvester **10** is intended to cut slabs of sod and to stack the slabs in flat condition on a pallet, as contrasted with sod harvesters which produce rolls of sod. Preferably, the sod harvester **10** cuts side-by-side strips of sod of sufficient total width to constitute an entire single layer on the pallet,
25 so as to simplify stacking the cut slabs of sod on the pallet (as will be explained). Typically, therefore, the harvester **10** may have three vibrating sod cutting knives **12-1**, **12-2**, **12-3** (best shown in Fig. 3) which undercut and side cut three side-by-side strips of sod **14-1**, **14-2**, **14-3** (Fig. 4A). Rollers **16-1**, **16-2**, **16-3** (Fig. 3) ahead of the cutting knives roll the sod before the sod
30 is cut, and vertically moving cross-cut knives **18-1**, **18-2**, **18-3** positioned

ahead of the rollers are driven into the ground at desired intervals to cut the strips of sod into lengths (i.e. into pieces or slabs of soil). Conventional fingers **20-1**, **20-2**, **20-3** attached to and extending rearwardly from the cutting knives guide the cut sod onto conveyors (to be described) of the sod harvester. Conventional means, not shown, are provided to lift the cutting knives and rollers above the ground when they are not being used for cutting, so that the harvester **10** can travel.

[0091] The vibrating sod cutting knives, rollers, cross-cut knives and fingers have all been well-known in the industry for many years and are shown, for example, in U.S. patent 3,509,944 issued May 5, 1970.

[0092] It is desirable that the three strips of sod **14-1**, **14-2**, **14-3** cut by harvester **10** be located closely adjacent each other from a side-by-side perspective, with minimal lateral gaps between them, so as not to leave narrow uncut (and wasted) strips of sod in the field being cut. Therefore, preferably the center sod cutting knife **12-2** and its associated roller **16-2** and cross-cut knife **18-2** are offset forwardly of the two outer sod cutting knives and rollers, as shown in Fig. 3. With this arrangement, the two outer knives and their associated mechanisms can be moved laterally inwardly toward the center sod cutting knife **12-2** to minimize or to reduce to zero any gaps between adjacent sod strips. (In some sod growing areas, where after harvesting sod is regrown from pieces of sod left in the field, then very narrow "ribbons" of uncut sod may be left between adjacent cut strips, to assist in regrowth of new sod after harvesting.)

[0093] In a typical harvester version, the center sod cutting knife **12-2** may be located, e.g. eight inches in front of the two outer sod cutting knives **12-1**, **12-3**, but this distance can be varied and different offset patterns can be used if desired. In the version shown in Fig. 3, the fingers **20-2** extending rearwardly from the center sod cutting knife **12-2** are longer than the fingers **20-1**, **20-3** of the two outer knives, to guide the cut sod onto the conveyors described below.

[0094] As best shown in Figs. 4A to 4D, the harvester **10** includes three sequential sets of conveyors **30**, **32**, **34** to move the cut sod pieces from the cutting knives rearwardly to a location from which the cut sod pieces can be picked up and transferred to a pallet or other desired support.

5 **[0095]** The first set of conveyors **30** includes two side-by-side conveyors **30-1**, **30-2** driven at slightly greater than ground speed (ground speed being the speed at which the machine travels over the ground) by a hydraulic motor diagrammatically indicated at **33**. The first set of conveyors **30** can consist of a single conveyor, or it can consist of three or four side-by-
10 side conveyors (any number can be used), but two side-by-side conveyors **30-1**, **30-2** have been found convenient from a production viewpoint. The conveyors **30-1**, **30-2** both operate at the same speed, and since they carry the cut sod upwardly at a relatively steep angle, elongated fingers **35**, pivotably mounted on a bridge **36** extending across the conveyors **30-1**, **30-2**,
15 are positioned to lie against the cut sod strips as the sod travels upwardly, to reduce slippage of the sod on the conveyors **30-1**, **30-2** and to prevent the leading edges of the cut sod strip from curling back downhill. As is well-known in the industry, the speed of hydraulic motor **33** is controlled by a hydraulic circuit (indicated at **145** in Fig. 10) which reads ground speed from a
20 conventional sensor **200**.

[0096] The second set of conveyors **32** also consist of two side-by-side conveyors **32-1**, **32-2** (although again, any desired number can be used). Again, elongated fingers **38** are provided, pivotably mounted on a bridge **40** extending across the second set of conveyors **32**, to overlies the sod strips as
25 they travel up the second conveyor set **32**, again to reduce slippage of the sod on the second conveyors and to prevent the leading edges of the sod strips from curling back. The second set of conveyors are driven in unison by a hydraulic motor diagrammatically indicated at **42**, preferably at approximately twice ground speed. Thus, when the sod strips **14-1** to **14-3**
30 reach the second set of conveyors **32**, as shown in Fig. 4C, the sod strips will

- 11 -

be accelerated away from the sod strips on the first set of conveyors **30**, leaving a gap indicated at **44** in Fig. 4C, for a reason to be described.

[0097] From the second set of conveyors **32**, the three side-by-side sod strips **14-1**, **14-2**, **14-3** next travel onto the third conveyor set **34**, which
5 consists of three side-by-side conveyors **34-1**, **34-2**, **34-3**, one to accommodate each sod strip. In a preferred embodiment, the outer third conveyors **34-1**, **34-3** are each divided into two sub-conveyors **34-1a**, **34-1b** and **34-3a**, **34-3b**. The sub-conveyors of each side conveyor **34-1**, **34-3** are
10 linked by a chain and sprocket mechanism **46** (Fig. 1) so that only one of the two sub-conveyors need be driven to drive both sub-conveyors of an outer conveyor. The division of each side third set conveyor **34-1**, **34-3** into two sub-conveyors provides a gap or depression **48-1**, **48-3** in the center of the top rear of these conveyors, to accommodate a cross-cut knife as will be explained.

15 **[0098]** Since there may not be space to divide the center third set conveyor **34-2** into two sub-conveyors, the center third set conveyor **34-2**, as shown in Fig. 4B, has a center depression **50** provided by three rollers **52**, to accommodate a cross-cut blade if a cross-cut is needed.

[0099] Each third set conveyor **34-1**, **34-2**, **34-3** is driven separately by
20 a hydraulic motor **60-1**, **60-2**, **60-3**. All three third set conveyors **34-1**, **34-2**, **34-3** preferably operate at approximately three times ground speed, thus accelerating the sod strips away from the sod strips following behind them on the second set conveyors **32** and producing a gap **62** (Fig. 4D) between the trailing edges of the sod strips on the third set conveyors and the leading
25 edges of the sod strips on the second set conveyors. The gap **62** is typically larger than the gap **44**.

[00100] In the operation of the sod harvester **10** as so far described, the three strips of sod **14-1** to **14-3** are cut by cutting knives **12-1** to **12-3** and cross-cut knives **18-1** to **18-3** and travel up the first and second conveyor sets
30 **30**, **32** as shown in Figs. 4A and 4C. Since the center cutting knife **12-2** and cross-cut knife **18-2** are positioned ahead of the two side knives, the center

- 12 -

sod strip **14-2** will be cut and released from the ground first and therefore its leading edge **64-2** on first conveyor set **30** will be ahead of (i.e. offset from) the leading edges **64-1**, **64-3** of the two side sod strips **14-1**, **14-3** (see Fig. 4A). This offset of leading edge **64-2** continues on the second set conveyors
5 **32** (see Fig. 4D).

[00101] When the sod strips **14-1** to **14-3** reach the third set conveyors **34**, they are accelerated onto those conveyors until their respective trailing edges **66-1**, **66-2**, **66-3** pass individual sensors **70** (Fig. 5) for each third set conveyor. The sensors **70** each consist of a tongue **72** which rests on its
10 associated third set conveyor and is attached at rotary connection **74** to a microswitch **76**. When a sod strip on a third set conveyor **34-1**, **34-2** or **34-3** passes out from under the tongue **72**, the tongue **72** drops slightly (by the thickness of the sod strip), operating the microswitch **76**. The three
15 microswitches **76** are connected to a computer (to be discussed) which then shuts off the third set conveyor **34-1**, **34-2** or **34-3** in question until the start of the next cycle (as will be described). The result of this individual control of the
20 third set conveyors **34** is that all three strips of sod **14-1** to **14-3** are automatically positioned on the third set conveyors **34** with their leading edges aligned (and therefore also with their trailing edges aligned), as shown in Fig. 4D (even though previously the leading edge **64-2** of the center sod strip **14-2** was ahead of the other two leading edges).

[00102] The third set conveyors **34** acts as a storage or buffer set of conveyors, providing a location from which the sod strips can be picked up and transferred to a pallet. The gap **62** between the leading edges of the sod
25 strips advancing up the second conveyor set **32**, and the trailing edges of the sod strips located on the third conveyor set **34**, provides a time period or time interval during which the sod strips on the third conveyor set **34** can be picked up and transferred to a pallet or other stacking location (or at least can be picked up and moved away from the third conveyor set) before the next set of
30 sod strips arrives at the third conveyor set.

[00103] A preferred mechanism for picking up the sod strips, moving them over a pallet, and depositing them on the pallet will next be described with reference to Fig. 6 and following. As there shown, the harvester **10** has a sod pick-up and transfer mechanism **80**. Mechanism **80** includes a gantry arrangement which comprises a guide frame **82** fixedly mounted on the harvester **10**, and a gantry **84** mounted on the guide frame **82** by wheels **86** (one at each corner of the gantry) so that the gantry can roll back and forth in a side-to-side direction on the frame **82**, with the wheels **86** supported and guided in channels **88** at the sides of the guide frame **82**.

[00104] The guide frame **82** extends over the third set conveyors **34** and also extends over a pallet **90** (Fig. 8A) supported on a forklift **92** located at one side of the third set conveyors **34**. A sod carrier **94** is suspended from the gantry **84** and serves to pick-up the sod from the third set conveyors **34**, after which (as will be described) the gantry **84** travels laterally to a position over the pallet **90**. The sod carrier **94** then deposits its layer of sod on the pallet **90**.

[00105] The sod carrier **94** includes side and end frame members **96**, **98** defining a frame for the sod carrier, and also includes upper frame members **100** spanning the side frame members **96** and connected thereto. A cross frame member **102** extends between the upper frame members **100** and supports half **104-1** of a ball joint **104**. The other half **104-2** of ball joint **104** is connected to a cross member **106** in the gantry **84**, so that the sod carrier **94** is suspended from the gantry **84** and is able to rock and tilt to a limited extent relative to the gantry **84**, and is also able to rotate with respect to the gantry **84**.

[00106] A rotate piston and cylinder **110** (Fig. 7) is connected between a frame member of the gantry **84** and the sod carrier **94**, the attachment point on the sod carrier being spaced from ball joint **104**. The piston and cylinder **110** is connected so that it can rotate the sod carrier **94** on the gantry **84** by 90° when commanded to do so. (Alternatively, a conventional rotary actuator can be used to rotate the sod carrier on the gantry.)

- 14 -

[00107] The gantry **84** is moved on guide frame **82** between a first position over the third set conveyors **34** (shown in Fig. 8A) and a second position over the pallet **90** (shown in Fig. 9B) by an elongated double-acting (two-ended) cylinder **112** which is mounted at **114** on upper frame member **106** of the gantry **84**. An elongated piston rod **118** extends through the cylinder **112** and is mounted at both ends, at **120**, **122**, to the guide frame **82**. A piston (not shown) is located in the cylinder **112**, so that as hydraulic fluid is injected into the cylinder **112** at either end (by hoses not shown), the cylinder **112** will travel back and forth in the direction of arrow **124**, carrying the gantry **84** with it, to move the gantry between the two positions described (one over the third set conveyors **34** and the other over the pallet **90**).

[00108] The sod carrier **94** suspended from the gantry **84** is essentially the same as that shown in U.S. patent application serial No. 10/780,616, filed February 19, 2004 entitled "Method and Apparatus for Picking Up Sod from the Top", published January 6, 2005, the description and drawings of which are incorporated by reference herein. Since the sod pick-up features of the sod carrier **94** are fully described and illustrated in such published patent application, those features will be described only briefly here. Specifically, the sod carrier **94** includes (see Figs. 7, 8A) a number of pairs of clamps **130** which extend parallel to each other at the bottom of the sod carrier **94**. The clamps **130** are strongly biased to a closed position by springs **132** but can be opened by a linkage **134** (not shown in detail in this application) which is operated by a piston and cylinder **136**.

[00109] In operation, as described, three sod strips travel up the first and second conveyor sets **30**, **32** and onto the third conveyor set **34**. Since the three sod strips are not usually perfectly aligned (as mentioned, the middle sod strip is ahead of the two side sod strips, and the two side sod strips may slip unequally on the conveyors), each conveyor of the third conveyor set is separately driven and controlled (as described) to shut off individually when its sod strip is properly positioned on the third conveyor in question. This ensures that all three sod strips on the third conveyor set are aligned evenly

- 15 -

with each other and ready to be picked up. If the sod is defective, the operator can manually override (using a manual control, not shown) the sensors which normally stop the third conveyor set **34** and can cause the third conveyor set **34** to continue operating, thus ejecting the defective sod pieces
5 onto the ground.

[00110] As shown in Fig. 1, the third conveyor set **34** is mounted in a bed frame **140** which can be raised and lowered using piston and cylinder sets **142** at each side of the bed frame (and with additional conventional guides, not shown). When the three sod strips are aligned on the third
10 conveyor set **34**, thus shutting off all of the third conveyors **34-1**, **34-2**, **34-3** as previously described, a computer **144** (described below in connection with Fig. 10) sends a signal to operate the pistons and cylinders **142** (part of hydraulic circuit **145**, Fig. 10), raising the conveyor bed frame **140** and pressing the sod strips on the third conveyor set **34** against the clamps **130** on
15 the underside of the sod carrier **94**. At this time, the sod carrier **94** is pushed against the gantry **84**, and the pressure is transmitted to the gantry by rubber pads **95** atop the sod carrier and which press against the underside of the gantry. Besides absorbing pressure when the sod carrier **94** is pushed against the gantry **84**, the rubber pads **95** serve an additional purpose. If the
20 sod strips on the third conveyor set **34** happen to be of uneven thickness, e.g. thicker at one side of the third conveyor set than the other, then the rubber pads **95**, together with the limited rocking and tilting permitted by ball joint **104**, permit the sod carrier **94** to tilt to compensate at least to some extent for the uneven thickness, allowing the clamps **130** to clamp all of the sod strips
25 on the third conveyor set **34**, rather than failing to clamp some of the sod strips.

[00111] If it is desired to cut the sod strips **14-1** to **14-3** each into two shorter pieces, a knife **146** (Fig. 4D) can be fixed in the underside of sod carrier **94** as described in the above-mentioned published pending
30 application, thus dividing each sod strip **14-1** to **14-3** into two parts. The computer **144** typically operates control solenoids valves **147** in the hydraulic

- 16 -

circuit **145** to operate the pistons and cylinders described. The pressure with which the conveyor bed frame **140** presses the sod strips on the third conveyor set **34** against the clamps **130** is preferably made adjustable, to allow better gripping of the sod by the clamps when the sod is of different soil
5 types. (For example, for tough soil, a higher pressure is needed.)

[00112] The pressure with which the bed frame **140**, and hence the sod strips **14-1** to **14-3** are pressed against the underside of the sod carrier **94** is sensed by a pressure sensor **148** (Fig. 10) connected to one of the piston and cylinders **142** which raise the bed **140**. When the pressure is sufficiently high,
10 this is detected by the computer **144** which then sends a signal to a solenoid valve controlling the clamp piston and cylinder **136**, depressurizing this piston and cylinder and allowing the springs **132** to snap the clamps **130** closed. The clamps **130** then grip the sod by its blades, as described in the above published co-pending application. In some cases, if the equipment is likely to
15 operate over muddy ground and if the mud may clog the clamps **130** and prevent them from gripping the sod strips properly, a series of hooks **150** (Fig. 11) may be added to the clamps, to provide improved grip by the sod carrier **94** on the sod strips. The hooks **150** are relatively short and will not support the sod strips by themselves, so that when the clamps **130** are opened, the
20 sod strips **14-1** to **14-3** (which are heavy) will quickly drop away from the sod carrier **94**. (If a sufficient number of closely spaced hooks **150** are used, then these hooks are capable of supporting the sod strips by themselves and can in effect constitute a clamp. When the hooks are separated by the clamp opening action, then the heavy sod strips will drop away from the hooks **150**.)
25 Alternatively, the clamps can be formed as a series of straight or curved fingers.

[00113] After sufficient time has been provided for the clamps **130** to close and to grip the sod strips (typically only a very short time will be required for this), the computer **144** sends a signal to a solenoid valve in the hydraulic
30 circuit **145** controlling pistons and cylinders **142** to lower the conveyor bed frame **140** so that the third conveyors will be in position to receive the next set

- 17 -

of sod strips when they arrive from the second conveyor set **32**. The computer **144** then also sends a signal to activate the gantry travel cylinder **112**. The gantry **84** then moves to the right as shown in Fig. 9A until the gantry **84** with the sod carrier **94** and the sod strips **14-1** to **14-3** suspended therefrom is over the pallet **90**. At this point, a proximity sensor **152** (Fig. 9A) on the guide frame **82** operates, sending a signal to the computer **144** which then stops the operation of cylinder **112**, ending further lateral travel of the gantry **84**. At the same time (or a few milliseconds later) the computer **144** sends a signal to the hydraulic circuit **145** to operate the clamp piston and cylinder **136** to open the clamps **130**, thus allowing the sod strips **14-1** to **14-3** which were suspended from the sod carrier **94** to drop onto the pallet **90**. After this operation has occurred, the computer **144** signals the hydraulic circuit **145** to operate gantry cylinder **112** in the opposite direction, to return the gantry and the sod carrier to the position shown in Figs. 8A and 9A, over the third conveyor set **34** and ready to pick-up another set of sod strips. A proximity sensor **153** at the other (home) end of guide frame **82** signals the computer **144** to stop this return gantry movement when the gantry **84** has returned to its starting (home) position. It will be realized that instead of, or in addition to, raising the conveyor bed frame **140**, the sod carrier **94** can be lowered so that the sod strips are contacted by the clamps **130** which press against the sod strips on the third conveyor set **34**, to then lift the sod strips.

[00114] When a pallet **90** is being loaded with sod strips or slabs, then after a number of layers have been deposited with the sod strips oriented in one direction, additional layers can be deposited with the sod strips oriented at 90° to the first direction, to tie together the load of sod strips on the pallet and to render it more stable. A typical loaded pallet **90** is shown in Fig. 12, with four layers of sod strips **160** running in one direction (perpendicular to the page) and the next four layers **162** running at 90° to the first direction. To accomplish this, the sod carrier **94** is, as previously described, mounted on the gantry **84** so that the sod carrier **94** can rotate through 90°, powered by piston and cylinder **110**. For this purpose, the gantry **84** contains (Figs. 7, 8A) a home sensor **166** and a home stop **170**, while the sod carrier **94** includes a

- 18 -

home stop **174** and an away stop **176** and an away sensor **168**. When the sod carrier is in the non-rotated position shown in Figs. 7, 8A, home stop **174** on the sod carrier **94** presses against home stop **170** and home sensor **166** on the gantry. In this condition, the computer **144** is signalled to maintain low
5 pressure in rotate cylinder **110** to hold the sod carrier **94** in the home position shown in Fig. 8A, and not to rotate the sod carrier **94** to a different position.

[00115] After a desired number of layers of sod have been deposited on the pallet **90**, then the computer will be signalled (by means to be described), after the sod carrier has picked up a load of sod strips to operate the rotate
10 cylinder **110** to rotate the sod carrier **94** by 90° with respect to gantry **84**. When the sod carrier **94** has rotated 90°, away sensor **168** on the sod carrier **94** will press against away stop **176** on the gantry **84**. The away sensor **168** sends a signal to the computer **144** to terminate the rotation but to maintain low pressure in the rotate cylinder **110** to hold the sod carrier **94** in the 90°
15 rotated position, so that sod strips can be deposited on the pallet **90** at 90° to the first set of sod strips. The computer **144** can be programmed to set as desired the number of layers of sod strips to be deposited on the pallet in one orientation before the next set of layers is deposited at 90° to the first set, and can also be programmed to adjust the number of sod layers deposited in one
20 orientation before a 90° rotation occurs. After the clamps **130** are activated to release the sod, the computer reverses the operation of the rotate cylinder **110** to return the sod carrier **94** to its non-rotated condition (as it returns to its home position).

[00116] The pallet **90** is supported on the forks **180** of a conventional
25 forklift **182** (best shown in Figs. 13, 14). The forklift **182** is located in a space beside the third conveyor set **34**, which space is of sufficient size to accommodate the pallet **90**. At the beginning of a sod harvesting operation, the forks **180** are raised upwardly so that the pallet **90** is positioned only a short distance below the sod carrier **94**, so that the sod strips when released
30 from the sod carrier will fall only a short distance and will be properly aligned on the pallet **90**.

- 19 -

[00117] As layers of sod strips are deposited on the pallet **90**, the pallet **90** will have to be lowered to make room for the increasing height of the layers stacked on the pallet. The lowering operation is controlled by an "electric eye", consisting of a light beam projector **184** (Fig. 15) mounted at one side of the pallet **90** and projecting its light beam **186** over the upper surface of the pallet to a photocell **188** on the opposite side of the pallet. Signals from the photocell are directed to the computer **144**. A brief interruption of the light beam **186** (caused by sod dropping from the sod carrier through the light beam onto the pallet) will not trigger any lowering of the pallet, but a longer duration interruption of the light beam **186** (e.g. one second or more) will cause the photocell **188** to send a signal to the computer **144**. The computer **144** then signals the hydraulic circuit **145** to cause the forklift left cylinder **180** to lower the forks **180**. The lowering can be by a fixed amount which is approximately equal to the thickness of a sod strip, or it can be until the photocell **188** receives the light beam again from the projector **184**, at which time the lowering operation is stopped by the computer **144**. The number of lowering steps which occur after the pallet **90** is loaded onto the forks **80** is counted by the computer **144**, and when the desired number of lowering steps has occurred, then the computer sends a rotate signal so that the next predetermined number of sod layers will be loaded onto the pallet **90** with the sod strips oriented at 90° to the previous set of layers.

[00118] It will be appreciated that for the 90° rotation feature to be effective, the sod carrier must pick-up the sod strips while in one orientation and must then rotate 90° in order to deposit the sod strips (on the pallet) at 90° to the first orientation. Therefore, the sequencing by the computer **144** is such that when the sod carrier **94** is positioned over the third conveyor set **34**, the sod carrier **94** is always in the "home" position indicated in Figs. 7 and 8A. The gantry **84** with the sod carrier **94** suspended therefrom can then travel to the "away" position shown in Fig. 9B, with the sod carrier **94** either in the Fig. 8A position, or rotated through 90° therefrom. The two alternative "away" positions of the sod carrier **94** can be referred to as the "unrotated away position" and the "rotated away position". The sod carrier **94** must be fully in

- 20 -

one of these two positions before the computer **144** will signal the hydraulic circuit **145** to open the clamps **130** and drop the sod strips onto the pallet **90**. Therefore, the signals from the proximity sensor **152** indicating that the gantry **84** has fully reached the "away" position, and from the sensors **166**, **168**
5 indicating that the sod carrier is fully either in the unrotated away position or in the rotated away position, are required before the clamps **130** are opened to release the sod strips.

[00119] It will be appreciated that the gantry **84** must travel back and forth rapidly, and that the sod carrier must rotate rapidly, to complete their
10 required movements in the relatively short time period available between the arrivals of successive sets of sod strips. The resultant rapid accelerations and decelerations can heavily shake the sod harvester **10**. To reduce this tendency, the sod harvester **10** is supported at its rear end, beneath the third set of conveyors **34**, by a heavy roller **192** (Fig. 15). The roller **192** serves to
15 dampen and reduce the amplitude of vibrations occurring when the gantry and sod carrier are accelerating and decelerating. The roller **192** also helps to support the load of the harvester, particularly when it is carrying a pallet loaded with sod and a stack of empty pallets, and also serves better to balance the machine. A piston and cylinder **194** can be provided to adjust the
20 weight division between the roller **192** and the rear wheels **196** of the harvester, and also to raise the roller **192** off the ground when the cutting knives are raised from the ground, so that the harvester **10** can travel.

[00120] In place of roller **192**, a set of wheels of a suitable hardness may be used.

25 **[00121]** When the pallet **90** is full of sod and is ready to be discharged, it is preferred that it be placed on the ground in a position in which it will be out of the path of the return movement of the sod harvester during a harvesting operation. Therefore, the forklift mast **200** is preferably mounted on a rod **202** (Figs. 13, 14) and can be side shifted using a side shift piston and cylinder
30 **204**, as is well-known in the industry, so that before the pallet **90** is lowered

- 21 -

onto the ground, it is side shifted as far as possible to one side of the harvester.

[00122] The foregoing description has discussed harvesting three side-by-side strips so that a complete layer for the pallet can be picked up and deposited on the pallet, thus eliminating the need for separate movements to build up a layer on the pallet from separate pieces. Transferring an entire layer onto the pallet is more efficient than transferring only part of a layer, although if desired, the features of the invention can be used to transfer part of a layer in one operation and then to transfer further parts of the layer in additional operations.

[00123] If the harvester **10** is used to harvest only a single wide slab or strip of sod and then send that strip up conveyors to be picked up and placed on a pallet, then variations can be made in the apparatus described. For example, while three sequential sets of conveyors are still desirable, with each travelling faster than the preceding set to produce a gap or time interval between the times when successive pieces of sod arrive at the buffer conveyor (i.e. at the third conveyor), it may be less necessary to have the third conveyor travelling faster than the second conveyor, since the gap produced by the differences in speed between the first and second conveyors may be sufficient for sod pick-up and deposit operations. In any event, while a one/two/three speed ratio is preferred for the three conveyor sets (i.e. ground speed for the first set, double ground speed for the second set, and three times ground speed for the third set), these speeds can be varied depending on the need, so long as a sufficient time interval is produced between the arrivals of successive sets of sod pieces to allow the set on the buffer conveyor or conveyors to be picked up. Also, additional conveyor sets can be included in the sequence, either for further movement of the sod, or to increase the size and duration of the gap between sod strips arriving at the buffer conveyor, or both.

[00124] Reference is next made to Figs. 17 and 18, which show diagrammatic views of a sod harvester according to the invention mounted on

- 22 -

the side of a tractor, rather than being pulled by a tractor. Prime reference numerals are used to indicate parts corresponding to those of Figs. 1 to 16.

[00125] The sod harvester **10'** shown in Fig. 17, 18 is essentially the same as that shown in the preceding Figs., with respect to the components used to harvest sod, move it upwardly and rearwardly along three sets of conveyors **30'**, **32'**, **34'**, and then pick up the sod slabs using the sod pick-up and transfer mechanism **80'**. However, the harvester **10'** is now mounted on the side of a tractor **210**, employing a conventional mounting mechanism (not shown).

10 **[00126]** The feature of particular interest in the harvester **10'** is the use of "bogie" wheels **214** which help to support the harvester. If the harvester is designed to cut a wide set of sod slabs, then the harvester will be heavy and needs the bogie wheels for support. As shown in Fig. 17, 18, the bogie wheels **214** are mounted on an axle **216** which has its axis aligned (in a front to rear direction) with the axis of axle **218** of the tractor rear wheels **220**. (As shown in Fig. 18, since bogie wheels **214** are of smaller diameter than the tractor rear wheels **220**, the bogie axle **216** is not aligned in a vertical direction with axis **218** of the tractor rear wheels, i.e. axle **216** is below axle **218**.)

[00127] The bogie wheels **214** are not fixed immovably to the harvester **10'**, but rather are mounted on a suspension comprising a beam **222** extending in a front to rear direction and supporting the axle **216**. The front end of beam **222** is mounted at pivot **224** on a cross beam **226** of the harvester **10'**, so that the harvester bogie wheels **214** can move upwardly and downwardly in the direction of arrow **228**.

25 **[00128]** The rear end of beam **222** is pivotably connected at **230** to a piston and cylinder **232**, the upper end of which is connected at pivot **234** to another cross beam **236** of the harvester **10'**.

[00129] With the arrangement shown, a desired amount of pressure can be applied to the bogie wheels **214**, using piston and cylinder **232**, to support a portion of the weight of the harvester. Appropriate damping means (similar

- 23 -

to a shock absorber) can if desired be incorporated into piston and cylinder **222**, to absorb shocks and provide some resiliency as the harvester **10'** travels over undulating ground. In fact, piston and cylinder **222** can be a shock absorber, pressurized with air. In addition, other suspension
5 arrangements can be used, e.g. a piston and spring combination.

[00130] Similar to the previous embodiment, the axle of the rear roller **192'** is supported by a beam **240** pivotably mounted at **242** to a fixed member **244** of the harvester. A piston and cylinder **246** pivotably connected between an extension **248** of the beam **240** and a fixed member **250** of the harvester
10 allows a desired amount of pressure to be transferred to the rear roller **192'**. In addition, as before, when the cutting knives of the harvester **10'** are raised out of the ground, the rear roller **192'** will normally also be automatically raised above the ground by piston and cylinder **246**, to allow for travel of the harvester **10'**. During such travel, the weight of the harvester **10'** will be
15 supported by the tractor **210** and by the bogie wheels **214**.

[00131] While the cutting knives **12-1'**, **12-2'**, **12-3'** have been shown in fixed relation, they can if desired be made adjustable. For example, as shown in Fig. 17, the right hand cutting knife **12-3'** can be fixed to the harvester, but the two left hand cutting knives **12-1'** can be made adjustable in a side-to-side
20 direction, e.g. by mounting them on a beam **252** with a number of sets of mounting holes, so that the knives **12-1'**, **12-2'** can be bolted to beam **252** using one of several available sets of mounting holes for each knife. In this way, the size of the narrow sod strip to be left in the field for regrowth after sod slabs have been cut and removed, can be varied depending on the sod
25 grower's preference. In Fig. 17, the sod cutting knives **12-1'** to **12-3'** have been shown as aligned in a front to rear direction, which assumes a moderate spacing between the sides of the sod slabs being cut. If a zero spacing is desired (as previously described), then the center knife **12-2'** can be offset forwardly or rearwardly, as previously discussed.

30 **[00132]** Reference is next made to Figs. 19 to 21, which show a different way of stacking sod on a pallet from that shown in Fig. 12, but which also

- 24 -

serves to tie the stacked sod on the pallet together. As shown in Figs. 19 to 21, a first layer **300** consisting of three sod strips is deposited on the pallet **90**. A second layer **302** also consisting of three sod strips is then deposited on top of the first layer **300**, but layer **302** is offset sideways by a small amount (e.g. one inch to two and a half inches, or more if desired) with respect to layer **300**. Then the next layer **304** is deposited on top of layer **302**, but with the side edges **304a** of layer **304** aligned with the side edges **300a** of the first layer **300** and therefore overlapping the side edges **302a** of layer **302**. The overlap is indicated at **305** in Fig. 19. As successive layers are stacked, each layer overlaps the side edges of the sod strips on the layer beneath it. The weight of the sod pressing on the overlapped portions ties the slabs of sod together when stacked on a pallet and makes unnecessary the need for rotating sets of layers through 90°, as described in connection with Fig. 12. This eliminates the need for the rotating mechanism of the sod carrier **94**, thus substantially simplifying the apparatus.

[00133] To practice the method described in connection with Figs. 19 to 21, the proximity switch **152** (Fig. 9A) which controls the position at which the sod carrier **94** ends its sideways travel and drops a layer of sod onto the pallet **90**, can be modified to sense the two overlapped positions required, or alternatively (and preferably) the computer **144** may be programmed simply to allow (for example) one inch or more of additional movement of the sod carrier **94** on each alternating trip of the sod carrier **94** over the pallet **90**.

[00134] Another way to practice the method described in connection with Figs. 19 to 21 is to use the feature that the forklift **182** has a side shift piston and cylinder **204** (Fig. 13). The side shift piston and cylinder **204** may be controlled by the computer **144** to shift the pallet **90** sideways by the required distance (e.g. one to two and a half inches, or more) just before the sod carrier **94** drops a layer of sod on the pallet **90**, so that alternating layers are overlapped as described.

[00135] In addition, instead of offsetting alternating layers (in which case each layer is offset with respect to the layer beneath it), such offsetting can be

- 25 -

done every third layer, or every fourth layer, or as desired, so long as the stack of layers are adequately tied together on the pallet **90**.

[00136] Reference is next made to Figs. 22 to 24, which show the situation when each sod strip **14-1** to **14-3** is cut into two pieces by a cross cut
5 knife such as knife **146** of Fig. 4D. In the example illustrated, this results in six sod pieces **14-10** to **14-15** inclusive. Each piece has a pair of longitudinal edges, indicated at **350**, and a pair of lateral or widthwise edges, indicated at **352**. When these layers are stacked on a pallet, overlap can be provided both
10 widthwise (as also shown in Figs. 19 to 21) and lengthwise (in which case at least some of the widthwise edges **352** are overlaid by the sod above them).

[00137] The overlapping of the longitudinal edges **350** can be accomplished, as described for Figs. 19 to 21, by programming the computer
15 **144** to cause the sod carrier **94** to travel to different positions over the pallet **90** as alternate layers of sod are deposited. Thus, using the signal from proximity switch **152**, and under control of computer **144**, the sod carrier **94** alternately deposits the sod on the pallet **90** in two positions, one overlapping the other by between one and two and a half inches (all dimensions are exemplary) to provide the widthwise overlap indicated at **354** (Fig. 22).

20 **[00138]** The lengthwise overlap of the widthwise edges **352**, such overlap being indicated at **356** in Fig. 22, may be provided in various ways. One method, as shown in Figs. 25 to 29, is to mount the forks **180** on the forklift mast **360** by a scissors mechanism diagrammatically indicated at **362**. The scissors mechanism **362** may be operated in conventional manner by a
25 piston and cylinder (not shown) to move the forks **180** in a lengthwise direction, towards and away from the mast **360** as shown in Figs. 25 to 28. This movement will shift the sod pieces in a lengthwise direction, producing the lengthwise offset or overlap indicated at **356** in Fig. 22. Again, operation of the scissors mechanism **362** is controlled by computer **144**, so that the
30 correct movement occurs at the correct time. The amount by which the

- 26 -

scissors are extended can be controlled by a microswitch or a proximity sensor, not shown.

[00139] As described in connection with Figs. 19 to 21, the lengthwise overlap **356**, as well as the widthwise overlap, can be of every alternate layer, or every second, third or fourth layer, or as desired so long as the stacks of sod pieces are tied together sufficiently to result in a stable pile of sod on the pallet **90**.

[00140] Figs. 25 and 26 show the scissors **362** retracted and the forks side shifted right, while Figs. 27 and 28 show the scissors **362** extended and the forks side shifted left.

[00141] In some cases, the harvester may cut a single wide sod strip **14**, as shown in Fig. 29, and such wide sod strip may then be cut into desired pieces **400-14** by knives **146A** (similar to knife **146**) located in the bottom of the sod carrier **94**. As before, the cutting occurs when the conveyor bed frame **140** carrying the sod strip **14** is pressed against the bottom of the sod carrier **94** (or when the sod carrier **94** is pressed against the third set conveyors **34** on the bed frame **140**). The sod piece **14** can in this manner be cut into any desired number of pieces, e.g. two pieces, three pieces, four or six pieces. Stacking of these pieces may be performed as described for Figs. 19 to 24, with each layer offset in a widthwise (lateral direction) as described for Figs. 19 to 21, and if the sod slab is cut crosswise into several pieces in a lengthwise direction, then the overlap will also be as described for Figs. 22 to 24, i.e. in a front to rear (lengthwise) direction.

[00142] Reference is next made to Figs. 31 to 37A, B, C which show diagrammatically an automatic pallet injector **400** according to the invention, to enable the harvester to cut sod continuously without having to stop to eject a completed sod stack and load a new pallet. It will be appreciated that if the harvester has to stop each time a loaded pallet is to be discharged, then use of the harvester will be much less efficient than if continuous operation were possible.

- 27 -

[00143] As shown in Figs. 31A, B, C, the pallet injector **400** includes a pallet support structure **402** comprising a set of support rails **404**. The rails **404** are spaced laterally apart to carry a stack **406** of pallets. The stack **406** of pallets is normally confined in a hopper shown in dotted lines at **408**. The
5 rails **404** and the bottom pallet **410** in the stack are located beneath and clear of the bottom of the hopper **408**.

[00144] The rails **404** support an injector sheet **412** which in turn supports the bottom pallet of the stack **406** and is movable on wheels **414** rolling on rails **404** between an extended position shown in Figs. 31A, B, C
10 and a retracted position shown for example in Figs. 32A, B, C. In the retracted position, the injector sheet **412** is located over the rails **404** and does not protrude beyond the front edge **413** of the hopper **408**. Any desired mechanism, e.g. pistons and cylinders (not shown) can be used to move the injector sheet **412** between its extended and retracted positions. Injector
15 sheet **412** can also move on slides or in any other known way. Proximity sensors or microswitches (not shown) control the extent of the extension and retraction of the injector sheet **412**, by sending position signals in conventional manner to computer **144**.

[00145] In Figs. 31 to 34A, B, C, the forks **180** are in a lowered position
20 (it is assumed that they have just discharged a pallet loaded with sod). In Figs. 32A, B, C, the injector sheet **412** is in its retracted position, and in Figs. 33A, B, C, the injector sheet **412** is shown in its extended position, supporting a pallet **410** over the forks **180**. The injector sheet **412** may typically include small barbs or the like, e.g. crosswise bars or tubes (not shown) to grip the
25 bottom of the bottom pallet **410** and move it forwardly, out from under the remaining pallets in the stack **406**. Movement of the remaining pallets in stack **406** is prevented by the walls of the hopper **408** in which they are located.

[00146] After the bottom pallet **410** has been dispensed from the stack
30 **406** of pallets and is located over the forks **180**, the pallet **410** is temporarily supported by the injector sheet **412** while stacking of sod pieces on pallet **410**

- 28 -

begins. It is necessary for injector sheet **412** to temporarily support the pallet **410** at this time, since the forks **180** will have just finished supporting a previously fully loaded pallet of sod and are not yet available to hold a new pallet. Since the harvester is continuing to harvest sod and needs to stack the
5 newly harvested sod without interruption, therefore the required temporary support of pallet **410** is provided by the injector sheet **412**.

[00147] Figs. 34A, B, C show the pallet **410** supported temporarily by the injector sheet **412** and with the first two, three or four (or more) layers of sod **420** stacked on the pallet **410**. The forks **180** are still shown in their lowered
10 position.

[00148] Figs. 35A, B, C show the forks **180** in raised position in which they have now taken over the job of supporting the pallet **410**, with several layers of sod **420** thereon. As will be evident from Figs. 31 to 33A, the injector sheet **412** contains laterally spaced apart slots **421** through which the forks
15 **180** can pass, so the forks can take over supporting the pallet from the injector sheet **412**. Although injector **412** has been shown as a sheet, separate tubes or rods can be used if desired to form the injector and to provide sufficient temporary support for the partly loaded pallet **410**. When the forks **180** take over the job of supporting the pallet **410**, they raise the
20 pallet above the position in which it was formally supported by the injector sheet **412**, by about two inches. The precise amount by which the forks lift the pallet above the injector sheet can be varied, but should be enough to ensure that the pallet is above the injector sheet **412** and does not obstruct withdrawal of the injector sheet **412** to its retracted position.

[00149] Once the forks **180** have taken over the task of supporting the loaded pallet **410**, the injector sheet **412** may be withdrawn to its retracted position (shown for example in Figs. 32, 36A, B, C). The harvester **10** then continues to stack sod on the pallet **410** until the pallet is fully loaded, as previously described, at which time the electric eye **184**, **188** (Fig. 15) causes
30 the computer **144** to control the forks **180** to lower the fully loaded pallet **410** to the ground for discharge (Figs. 36A, B, C). When the pallet **410** is lowered

- 29 -

to the ground, then since it is facing rearwardly, it will be discharged as the harvester moves forwardly away from it. Downward movement of the forks **180** at this time is terminated by a proximity sensor **421** at the bottom of the fork mast. Sensor **421** signals the computer **144** to end lowering of the forks
5 at this time. After the loaded pallet has been discharged from the forks **180** (the computer provides a short time interval for this after proximity sensor **421** has been activated to stop the lowering of the forks), then the computer **144** causes the forks to be raised again, to support a new pallet which has been injected.

10 **[00150]** A second electric eye sensor, shown in Fig. 35C as having a light beam projector **422** and a photocell **424**, is located below the electric eye **184, 188**. Electric eye **422, 424** senses when the top of the finished sod stack passes photocell sensor **424** on the travel of the finished sod stack down to the ground. The signal from the second electric eye **422, 424** is transmitted to
15 the computer **144** to inform the computer that the top of the loaded pallet being lowered is now below the level of the injector sheet **412**. The computer then actuates the injector sheet **412** to remove a new pallet from the bottom of the stack **406** and to move it forward into the sod stacking position shown for example in Fig. 34A, B, C. As described, the injector sheet **412** remains in its
20 extended position and supports the new pallet **410** for stacking of the first two or more layers of sod, to allow time for the previous sod laden pallet to be ejected and for the forks **180** to rise back up to support the new pallet **410**. The upward travel of the forks **180** at this time may be controlled and stopped by a proximity sensor, diagrammatically indicated at **426**, on the mast **360**. As
25 mentioned, the forks are stopped after they have raised the new pallet **410** clear of the injector sheet, to allow the injector sheet to be withdrawn. A sequence detector function in the computer **144** detects that the upward movement of the forks has terminated, and then signals the injector sheet **412** to return to its retracted position shown, for example, in Figs. 32A, B, C.

30 **[00151]** The proximity sensor or microswitch (not shown) which terminates the movement of the pallet injector sheet **412** back to its retracted

- 30 -

position, also signals or enables the start of the first set **184, 186** (Fig. 15) of electric eyes' function to lower the forks **180** during stack building as required. (It will be understood that the forks **180**, when they are supporting a loaded pallet, should not be lowered until after the injector sheet **412** has been fully retracted, so that the pallet does not interfere with the injector sheet retraction.)

[00152] While the lowering of the fully loaded pallet during stack building has been described as initiated by the first electric eye set **184, 185**, such lowering can be accomplished in other ways. For example, the computer **144** can count the layers deposited on the pallet by the sod carrier, and after the count has reached (for example) 30 to 35 layers, then lowering of the loaded pallet can be initiated.

[00153] Reference is next made to Figs. 38, 39 which show an alternative and relatively low cost way of obtaining overlap between slabs of sod stacked in successive layers on a pallet. As shown in Figs. 38, 39, each layer **500, 502** (only two layers are shown) may be rotated slightly, typically between 5° and 10°, with respect to the layer below it. For example, the second layer **502** may be rotated 5° to 10° counterclockwise (as shown) with respect to the first layer **500**. The third layer (not shown) may be aligned with the first layer **500**. The fourth layer (not shown) may be aligned with the second layer **502**. A 5° rotation of a sod layer that is 48" by 48" will produce approximately a two inch overlap, or overhang, as indicated at **504** in Fig. 38.

[00154] With the method of stacking shown, sufficient overlap is achieved to tie the stack together so that it is more resistant to damage when travelling. Since the amount of rotation used is small, the limited rotation needed can be achieved quickly (in much less time than that needed for a 90° rotation). In addition, since only limited rotation is used, the loaded pallet is not appreciably larger in plan view from a pallet where no overlap between successive sod layers is provided.

- 31 -

[00155] The rotation needed for the overlap in Figs. 38, 39 can be achieved by any appropriate mechanism. For example, the rotate cylinder mechanism 110 of Fig. 7 can be used.

[00156] Reference is next made to Figs. 40, 41, which show another way of achieving overlap between successive layers of sod slabs. As shown in Fig. 40, a pair of vertical piling walls 510, 512 are provided. The walls 510, 512 define a piling cavity 514 which accommodates a pallet 520 with very close tolerances, thus forming a "tight" piling cavity. The pallet 520 is located in cavity 514 and is initially above the bottom edges 516 of the piling walls 510, 512.

[00157] In operation, a first layer 520 (formed by three sod slabs) is deposited into the cavity 514 in a position displaced toward one of the piling walls 510, so that one edge 522 of the first sod layer is curled upwardly.

[00158] A second sod layer 524 is then deposited into the piling cavity 514 in a position such that the edge 526 of the second sod layer opposite to the edge 522 of the first sod layer is displaced toward the piling wall 512, causing the edge 526 of the second sod layer to curl upwardly. This process is continued with alternate sod layers, resulting in the stack shown in Figs. 40, 41, in which sod layers slightly overlap the sod layers beneath them. To achieve this result, each sod layer must be moved to a sideways offset position with respect to the sod layer below it. This can be accomplished, for example, by any of the mechanisms previously described. Since the sod is not resilient, but rather is somewhat moldable, it is found, as shown in Fig. 41, that the upturned edges of the sod layers remain upturned when the pallet is removed from the cavity 514, thus helping to tie the sod stack together. An advantage of this system is, for example, that 54 inch side sod slabs can be cut (instead of the usual 48 inch slab), and yet because of these upturned edges on the pallet, they will only occupy a width of (for example) 50 inches, thus enabling storage of more sod on a pallet of given width.

[00159] Reference is next made to Figs. 42A, 42B to Figs. 47A, 47B, all of which show various forms of pallet which cause a concave (as viewed from

- 32 -

above) stack of sod slabs to be formed. In Figs. 42A, 42B, a pallet **540** is shown having a shallow V-shaped upper surface **542** (as viewed from one end of the pallet). The V-shaped upper surface **542** results from forming the pallet to be thicker at its side edges **544** than at its center **546**.

5 **[00160]** When sod is stacked on the pallet **540**, as shown in Fig. **48**, the stack **550** of sod layers will have a concave upper surface **552**, i.e. its outer edge portions will extend upwardly as well as outwardly. This acts in a manner similar to overlapping the sod slabs and thus strengthens the sod stack against falling apart during travel. Since this method does not require
10 any side shifting or rotation of the sod slabs, the machine for stacking the sod can be simplified, although there is a cost for the special pallets.

[00161] The pallet **540-2** shown in Figs. 43A, 43B is similar to pallet **540** shown in Figs. 42A, 42B except that the upper surface **542-2** of the pallet **540-2** is concavely curved, rather than being V-shaped.

15 **[00162]** The pallet **540-3** shown in Figs. 44A, 44B is simplified in that it has a flat upper surface with upwardly protruding edges **552** (which if the pallet is made of wood can be formed simply by adding an extra piece of wood or rail **554** to each side of the pallet). Provided that the pallet is no wider than the layer of sod to be deposited on it, the upwardly protruding
20 edges **552** will cause a sod stack deposited on the pallet to have a concave upper surface, with upwardly and outwardly protruding edges, as described in connection with Fig. 48.

[00163] If desired, and as shown in Figs. 45A, 45B, the upwardly protruding rails **554** which have been added to the side edges of the pallet
25 can be located on all four sides of the pallet **540-4**, thus making the sod stack piled on this pallet even more resistant to vibration.

[00164] Figs. 46A, 46B show a pallet **540-5** having a concave upper surface formed from three flat sections **560**, **562**, **564**. The outer sections **560**, **564** provide openings **566** at each lower side of the pallet for a forklift.

[00165] Alternatively, the pallet **540-6** can as shown in Figs. 47A, 47B have a V-shaped upper surface with side edges dimensioned such that the bottom center of the "V" **570** as well as the bottoms of the side edges **544-6** all rest on the ground, providing three lines of support for the pallet **540-6**.

5 [00166] In some cases, it may be desirable to cut an elongated slab of sod, as shown at **580** in Fig. 49, and then to cut slab **580** partially into two sections **580-1**, **580-2** which are connected by small pieces of earth and root **582**. The two pieces or sections **580-1**, **580-2** can readily be pulled apart when the sod is to be laid, but prior to being pulled apart, the connecting
10 portions **582** perform a function similar to overlapping, in that they tie the two pieces **580-1**, **580-2** together and thus help stabilize the sod stack against falling apart during activities such as transporting the sod stack.

[00167] To perform its function of leaving the two parts of the sod slab **580** connected, the cross-cut knife **584** (which normally cross-cuts the sod
15 while the sod is still in the ground) is provided with two notches **586**, each extending from the lower edge **588** of the cutting knife **584** upwardly and having a height approximately equal to the thickness of the sod slab. The height can be slightly less than the thickness of the sod slab (which would weaken the connection) or it can be equal to or greater than the height of the
20 sod slab, which would leave a connection of thickness equal to the full thickness of the sod slab **580**.

[00168] Reference is next made to Figs. 50A, 50B, 50C, which show variations of the notches in the cross-cut knife **584**. In Fig. 50A, a single V-shaped central notch **590** is provided in the bottom of the cross-cut knife **584**,
25 so that the two sections of the sod slab **580** will be connected by a single connecting portion, which can be of desired width to achieve a suitable compromise between having the two sod sections **580-1**, **580-2** connected together strongly enough to resist falling apart of the sod stack, and being able to pull the two sections **580-1**, **580-2** of the sod slab apart for sod laying
30 purposes.

[00169] In Fig. 50B, a single rectangular notch **592** is provided at the center of the lower edge of the cross-cut knife **584**.

[00170] In Fig. 50C, the two bottom outer corners of the cross-cut knife **584** are each bevelled or sloped, as indicated at **594**, so that a connecting portion of sod slab will occur at each side of the sod slab **580**. (It is assumed
5 that the width of the sod slab, which is set by the standard side cutting knives used in sod harvesters, is equal to the width of the cut-off knife **584**.)

[00171] Fig. 50D shows a cut-off knife **584** similar to that shown in Fig. 50C, but with a rectangular notch **596** at each bottom corner of the knife **584**,
10 thus also leaving a connecting portion at each side of the sod slab **580**, connecting the two sections of the sod slab.

[00172] Fig. 50E shows a combination of a cross-cut knife **584**, and two conventional side cutting knives **600**, with the side cutting knives **600** spaced slightly outwardly laterally of the side edges of the cross-cut knife **584**. In
15 other words, the cross-cut knife **584** does not span the full width of the sod slab being cut, and thus also leaves small connecting portions **582** between adjacent sections.

[00173] It may be desired to leave the small connecting portion or portions **582** between some sod slab sections, but not others. For example,
20 sod slab **580** may be cut into two connected portions **580-1**, **580-2** as described, but it may be desired to cut the next slab (not shown) completely free of slab **580**. This can be accomplished by providing additional cut-off knife sections shown in dotted lines at **602** in Fig. 50E. Knife sections **602** are normally positioned out of the gaps **582** but can be moved into gaps **582** by
25 any desired means, to produce a full cut completely across the width of the sod slab **580**.

[00174] It will be realized that sod harvesting and stacking machines of the kind described may be used to harvest sod from many different fields of sod. In some cases, it may be important not to contaminate a field containing
30 one variety of sod with seeds and roots from a different variety of sod which

- 35 -

was growing in a field on which the harvester was previously working. The danger of such cross-contamination between two fields of sod can be reduced by providing the harvester with an air compressor, shown for example in dotted lines at **610** in Fig. 2. The air compressor **610** is connected to one or
5 more air hoses **612** (also shown in dotted lines in Fig. 2), and each equipped with a conventional trigger operated blowing nozzle **614**. The air compressor **610** can be separately powered by its own gasoline engine, or it can be operated by a hydraulic motor on the harvester **10**, or it can be operated from the powered take-off of the towing vehicle. In use, when the harvester is
10 moving to a new field containing a different variety of sod than was previously harvested, the air compressor **610** is started and the nozzles **614** are used to clean with compressed air the parts of the harvester **10** which are most likely to carry seeds or root portions, e.g. the undercutting, side cutting and cross-cutting knives, the roller, and the sod conveyors and sod transport
15 mechanisms.

[00175] As previously discussed in connection with Figs. 17, 18, the harvester may have a plurality of sod cutting heads, e.g. three such heads to cut three side-by-side strips of sod. Depending on the nature of the sod, it may be desirable to leave uncut strips of sod in the field between the cut
20 strips which have been removed. The uncut strips may need to be of various widths, depending on the nature of the sod, the soil and the growing conditions. In some cases, it may be desired not to leave any uncut strip between the cut strips, but rather to clear cut the field and then to regrow a new crop of sod by reseeding the field. To facilitate adjustment of the sod
25 cutting heads for this purpose, for example, where three sod cutting heads **650, 652, 654** (Fig. 51) are used, two of the sod cutting heads **650, 652, 654** may be mounted for transverse sliding movement on a mounting frame **656** at the front of the harvester **10**". Where the harvester **10**" is mounted on the side of a tractor **210**, the two movable heads can be the two outermost heads
30 (away from the tractor), i.e. heads **650, 652**. Each head **650, 652, 654** will preferably include a complete conventional sod strip cutting mechanism, including cross-cut knife, undercutting knife with side cutting blades, a

- 36 -

hydraulic motor and mechanism to power the knives, a depth adjustment linkage, and a sod roller (all of these parts are conventional). The heads **650**, **652** are both mounted for lateral sliding movement on a transverse frame **660** and can be moved laterally back and forth by pistons and cylinders
5 diagrammatically indicated at **662**, **664**. In this manner, the lateral distance between the sod cutting heads **650**, **652**, **654** can be easily adjusted to set the width of the uncut strips between the cut sod strips. If desired, additional clamp locks (not shown) can be provided to clamp the cutting heads to the transverse frame **660** at their set positions, in case of hydraulic fluid leakage
10 from the pistons and cylinders **662**, **664**.

[00176] Finally, reference is made to Figs. 52, 53, which show a modified cross-cut blade arrangement which is suitable for use when a very wide sod slab is to be cut from the ground. When a wide sod slab is to be cut, a set of several undercutting knives may be used, one positioned beside the
15 other, and with only the outer sod undercutting knives having side cutting blades to cut the edges of the slab. With such an arrangement, if the ground being cut is uneven, the side-by-side sod undercutting knives can adjust to the unevenness (since each is supported by a roller of relatively short lateral width). However, if a single cross-cut knife is used, and if the ground is
20 uneven (for example, if there is a shallow V-shaped gully in the ground being cut), then the cross-cut knife will not cross-cut the full width of the sod slab uniformly and may not penetrate deeply enough into the ground at certain points. If this occurs, then the sod slabs being cut may not be sufficiently separated from each other, and this can cause serious problems during rolling
25 or stacking.

[00177] In the arrangement shown in Figs. 52, 53, three cross-cut knives **700**, **702**, **704** are mounted side-by-side on a cross-cut frame **706**. Each knife **700**, **702**, **704** is pivotably mounted by a pivot **710**, **712**, **714** on a plate **720**, **722**, **724**. The plates **720**, **722**, **724** are supported by further pivots **730**, **732**,
30 **734** on the cross-cut frame **706**.

- 37 -

[00178] The pivots **710**, **712**, **714** have axes which are generally horizontal and which are generally aligned with the path of travel of the harvester, so that the cross-cut knives can align themselves with the contours of the ground being cut. The pivots **730**, **732**, **734** have axes which are
5 generally horizontal and generally transverse to the path of harvester travel, so that (as is conventional), after the cross-cut knives penetrated the ground, these knives can tilt rearwardly (as the harvester travels forwardly) until they are lifted out of the ground.

[00179] A conventional mechanism is used to operate the cross-cut
10 knives shown. In a conventional cross-cut mechanism, the cross-cut blade is raised against the pressure of a heavy spring by a cam; then the cam suddenly removes lifting support, allowing the spring or springs to drive the cross-cut blade into the ground. A similar arrangement is used in the embodiment of Figs. 52, 53. As shown, the cross-cut frame **706** is mounted
15 to the main frame **750** of the harvester, with guides (not shown) constraining the cross-cut frame **706** to move vertically up and down on the harvester frame **750**. As is usual for cross-cut mechanisms, leaf springs (not shown) are provided to strongly bias the cross-cut frame **706** downwardly. The cross-cut frame **706** is, however, supported by two laterally spaced cam followers
20 **754**, **756** which ride on the peripheries of a pair of cams **760**, **762** mounted on a shaft **764** which is supported at its ends on the main frame **750** of the harvester. As is usual, the cams **760**, **762** rotate at ground speed, periodically raising the cross-cut frame **706** and then suddenly removing lifting support from it (at the rearwardly inwardly extending sections **770**, **772** of the cam
25 profiles), thus periodically allowing the cross-cut frame to drive the cross-cut knives **710**, **712**, **714** into the ground to cross-cut the sod.

[00180] Reference is next made to Figs. 54 and 55, which show another aspect of the invention. As there shown, there are two third set conveyors **34-1**, **34-2**. Each third set conveyor is divided into (for example) three
30 subconveyors **34-1a**, **34-1b**, **34-1c**, and **34-2a**, **34-2b**, **34-2c**. The subconveyors of each third set conveyor **34-1**, **34-2** are linked together by

- 38 -

chain and sprocket mechanisms (not shown) similar to chain and sprocket mechanism **46** of Fig. 1, so that only one of the three subconveyors of each third set conveyor need be driven to drive all three subconveyors of a third set conveyor.

5 **[00181]** The division of each third set conveyor **34-1**, **34-2** into three subconveyors provides two gaps or depressions **800**, **802** in the top of each of these conveyors, to accommodate cross-cut knives as will be explained.

[00182] To bridge the gaps between the subconveyors of each third set conveyor **34-1**, **34-2**, pairs of wedge-shaped members **804** are mounted one
10 between each adjacent pair of third set subconveyors (and are supported on the conveyor frame by means not shown). Each wedged-shaped member **804** has a slot **806** therein to accommodate the blade of a cross-cut knife (to be described).

[00183] The sod carrier **808** (which may be essentially the same as sod carrier **94** of Figs. 1 and following) supports two cross-cut knives **810**, **812**,
15 which are suspended over the slots **806** in the third set conveyors **34-1**, **34-2**. Thus, when the sod carrier **808** is lowered onto sod (not shown) on the third set conveyors **34-1**, **34-2**, the cross-cut knives **810**, **812** penetrate the sod and cut it into shorter lengths. The slots **806** allow the cross-cut knives **810**, **812**
20 to penetrate fully through and slightly beyond the full thickness of the sod on the third set conveyors during the cross-cut operation. As previously described, either the sod carrier **808** can be lowered onto the sod on third set conveyors **34-1**, **34-2**, or the third set conveyors can be raised and pushed against the sod carrier **808**, or a combination of these two operations may
25 occur. At this time, as previously described, the third set conveyors **34-1**, **34-2** are stationary (this is possible because of the wide gap between successive strips of sod; see Fig. 4c), thus allowing the sod strips on them to be cross-cut and picked up from the third set conveyors before the next set of sod strips arrives.

30 **[00184]** By way of example, the sod strip on each third set conveyor **34-1**, **34-2** can be 48 inches long by 24 inches wide. When the 48 inch length is

- 39 -

cut into three equal length pieces, each piece will be 16 inches long. Thus, after cross-cutting, each third set conveyor will carry three sod slabs, each sod slab being 16 inches by 24 inches, for a total sod dimension of 48 inches by 48 inches (divided into six easy to handle sod slabs). The entire set of six
5 sod slabs can be picked up and deposited on a standard 48 inch by 48 inch pallet, using the sod carrier **808** in the same manner as sod carrier **94**, as described previously in this application.

[00185] As another example, the sod strip on each third set conveyor can be 48 inches long by 48 inches wide, and can be cut into four 24 by 24
10 inch pieces. Alternatively it can be cut into six 16 by 24 inch pieces. The third set conveyors can be divided into subconveyors as needed for the dimensions selected, and the cutting knives can be positioned as needed.

[00186] If desired, the sod strip on each of the third set conveyors **34-1**, **34-2** can be divided into only two pieces (as previously described), or it can
15 be divided into more than three pieces, by using additional cross-cut knives and third set conveyor subsections (not shown).

[00187] If the sod harvester **10** is cutting with only one cutting head **12-1**, then there will be only one third set conveyor **34-1**, divided (for example) into three subconveyors **34-1a**, **34-1b**, **34-1c**. In that case, the sod carrier **808**
20 may be divided into two or three sections across its width, with the sod gripping clamps **130** of each section being separately operable (e.g. using separate actuating cylinders) to pick up sod. The three sections are indicated at **820**, **822**, and **824** in Fig. 56 (with the clamp mechanisms omitted for clarity). In that case, the sod carrier **808** can be positioned with section **824**
25 over the third set conveyors **34-1** to cross-cut and pick up a strip of sod on those conveyors. The sod carrier **808** can then be raised and moved laterally one conveyor width in the direction of arrow **826**, to bring the center section **822** of the sod carrier **808** over the third set conveyor **34-1**. After the next strip of sod arrives and stops on the third set conveyor **34-1**, the sod carrier
30 **808** is lowered so that its center section **822** cross cuts and picks up that strip of sod. The sod carrier **808** is then stepped once more in the direction of

- 40 -

arrow **826** so that its third section **820** is located over the third set conveyor **34-1**, ready to pick up the next sod strip which arrives and stops there. When the sod carrier **808** has been filled in this manner, it is then moved over a pallet to deposit its sod on the pallet, as previously described.

- 5 **[00188]** While preferred embodiments of the invention have been described, it will be appreciated that various changes can be made, and such changes are intended to be included within the appended claims.

Claims:

1. A sod harvester adapted for travel along a path of travel and comprising:
 - a) a sod cutting knife for cutting pieces of sod from the ground, each piece having a leading edge and a trailing edge,
 - b) a conveyor mechanism for carrying sod away from said cutting knife to a first location, and
 - c) a sod pick-up mechanism for picking up sod from said first location and for moving such sod to a second location and for then returning to said first location to again pick up sod at said first location,
 - d) said conveyor mechanism including a plurality of conveyors in sequence including a first conveyor for receiving a sod piece from said cutting knife and a second conveyor for receiving and accelerating said sod piece toward said first location to create a time period between the passage of the trailing edge of one sod piece and the arrival of the leading edge of the following sod piece,
 - e) said conveyor mechanism further including a mechanism for supporting a said sod piece in a stopped condition at said first location, while a following sod piece is moving towards said first location,
 - f) said time period being sufficient for a said sod piece to assume said stopped condition at said first location and for said sod pick-up mechanism to pick up and remove the stopped sod piece from said first location before the following sod piece arrives at said first location.

2. A sod harvester according to claim 1 wherein said conveyor mechanism comprises three conveyors in sequence, namely a first conveyor, a second conveyor and a third conveyor, said first conveyor receiving sod from said cutting knife, said second conveyor receiving sod from said first conveyor, said third conveyor receiving sod from said second conveyor, wherein said third conveyor constitutes said first location.

2006209823 11 Oct 2011

3. A sod harvester according to claim 2 wherein said third conveyor is driven faster than said second conveyor.
4. A sod harvester according to claim 3 and being adapted to travel over the ground at a ground speed while harvesting, and wherein said first conveyor is driven at a speed which is equal to or slightly greater than said ground speed, said second conveyor is driven at a speed which is approximately double said ground speed, and said third conveyor is driven at a speed which is approximately three times said ground speed.
5. A sod harvester according to claim 2 and having a plurality of cutting knives located side-by-side to cut a plurality of side-by-side sod pieces.
6. A sod harvester according to claim 5 wherein there are three sod cutting knives, namely, a center sod cutting knife and two outer sod cutting knives one on each side of said center sod cutting knife, and wherein said center sod cutting knife is offset along said path of travel from said outer sod cutting knives.
7. A sod harvester according to claim 6 wherein said center sod cutting knife is offset forwardly along said path of travel with respect to said outer sod cutting knives.
8. A sod harvester according to claim 2 and including a pallet support beside said third conveyor for supporting a pallet, said pallet support constituting said second location, a gantry guide structure mounted over said pallet support and said third conveyor, a gantry mounted on said gantry guide structure for movement back and forth over said first and second locations, and a sod pick-up carrier mounted on said gantry for picking up sod from said first location and releasing said sod at said second location.
9. A sod harvester according to claim 8 wherein said sod pick-up carrier includes clamps for clamping an upper portion of said sod to pick up said sod and for releasing said upper portion to release said sod at said second location.

2006209823 11 Oct 2011

10. A sod harvester according to claim 9 wherein said third conveyor is mounted on a third conveyor bed, and including a mechanism for raising said third conveyor toward and pressing it against said clamps so that said clamps can grip sod on said third conveyor, and for then lowering said third conveyor for said third conveyor to receive new sod.

11. A sod harvester according to claim 10 and including a knife mounted in said sod carrier for cutting said sod on said third conveyor when said third conveyor is pressed against said sod carrier.

12. A sod harvester according to claim 8 wherein said sod carrier is mounted for rotary movement on said gantry, said harvester including a control circuit for rotating said sod carrier through 90° at selected times after said sod carrier has picked up sod, thereby to tie together pieces of sod stacked on a pallet.

13. A sod harvester according to claim 8 wherein said sod pickup carrier is mounted on said gantry for limited tilting with respect to said gantry, thereby to provide at least some compensation for uneven thickness of sod on said third conveyor.

14. A sod harvester according to claim 1 and including a forklift for supporting a pallet on which sod is to be stacked, and further including a control circuit for lowering said pallet by approximately the thickness of said sod after a piece of said sod has been deposited on said pallet.

15. A sod harvester according to claim 1 and adapted to be mounted on the side of a tractor, said tractor having rear wheels having an axis, said harvester including at least one support wheel mounted behind said sod cutting knife for supporting a portion of the weight of said harvester, said support wheel having an axis aligned in a front to rear direction with said axis of said wheels of said tractor, a suspension connecting said support wheel to said harvester, said suspension permitting upward and downward movement of said support wheel as said harvester travels over undulating ground.

16. A sod harvester according to claim 15 wherein said suspension includes a piston and cylinder, and a control for controlling the pressure in said piston and cylinder to adjust the portion of weight of said harvester which is supported by said rear wheel.

17. A sod harvester adapted for travel along a path of travel and further adapted to be mounted on the side of a tractor, said tractor having rear wheels having an axis, said sod harvester comprising a sod cutting knife for cutting pieces of sod from the ground, a conveyor mechanism for carrying sod rearwardly from said cutting knife, and a support wheel located behind said cutting knife to support a portion of the weight of said harvester, said support wheel having an axis aligned in a front to rear direction with said axis of said tractor rear wheels, said support wheel including a suspension mounting said support wheel to said harvester, said suspension including a piston and cylinder connected to said harvester and acting to control the proportion of the weight of the harvester placed on said support wheel.

18. A sod harvester according to claim 17 and further including a rear rolling support located behind said support wheel, said rear rolling support being connected to said harvester by a movable linkage, and a piston and cylinder connected between said movable linkage and said harvester to control the proportion of the weight of said harvester supported by said rear rolling support.

19. A method of harvesting sod comprising:

a) continuously cutting pieces of sod, each piece having a leading edge and a trailing edge,

b) conveying said pieces of sod sequentially to a first location,

c) while performing said conveying, accelerating each sod piece away from the sod piece behind it to create a time interval between the passage of the trailing edge of one sod piece and the leading edge of the next sod piece, and

d) stopping a sod piece at said first location and while said sod piece is stopped, picking up said sod piece and then moving such sod piece to a second location,

- e) the steps of stopping and picking up being performed in said time interval.
20. A method according to claim 19 wherein said sod piece at said first location is on a conveyor, and wherein the step of picking up said sod piece is performed by a sod carrier, the step of picking up said sod piece including pressing one of said conveyor and said sod carrier toward the other of said conveyor and sod carrier.
21. A method of harvesting and handling sod comprising:
 - a) cutting an elongated sod slab, and
 - b) cutting said sod slab into two sod sections, but leaving uncut at least one small sod connection between said two sod sections, thereby to tie together said sod sections in a stack containing said sod sections.
22. A method according to claim 21 and including leaving at least two small sod connections between said two sod sections.
23. A method according to claim 22 wherein said two sod connections are at the outer edges of said sod sections.
24. A method according to claim 22 wherein said two sod connections are spaced inwardly from the outer edges of said sod sections.
25. A method according to any one of claims 21 to 24 wherein the step of cutting is performed by a cross-cut knife while said sod is in the ground and before it has been undercut and side cut.
26. A method of harvesting and handling sod comprising:
 - a) cutting an elongated sod slab,
 - b) moving said sod slab onto a conveyor using a sod carrier and stopping said sod slab on said conveyor,

2006209823 08 Nov 2011

c) cross-cutting said sod slab into at least two pieces while said sod slab is stopped on said conveyor, and

d) picking up said pieces of said sod slab for deposit of said pieces on a sod stack

wherein said sod carrier includes at least first and second side-by-side and separately operable sod pick-up mechanisms, said moving step further comprising:

(i) positioning said sod carrier over said conveyor so that said first pick-up mechanism is over said sod slab,

(ii) picking up said sod slab with said first sod pick-up mechanism,

(iii) moving a new sod slab onto said conveyor,

(iv) moving said sod carrier to position said second sod pick-up mechanism over said new sod slab on said conveyor,

(v) picking up said new sod slab with said second sod pick-up mechanism, and moving said sod carrier to deposit sod picked up thereby onto a sod stack.

27. A method according to claim 26 wherein said sod carrier having at least one cross-cut knife mounted thereon for performing the step of cutting said sod slab into said at least two pieces.

28. A method according to claim 27 and including the step of cross-cutting said sod slab into at least three pieces.

29. A method according to claim 28 wherein said sod slab is approximately 48 inches long by 24 inches wide and in said step of cross-cutting, said sod slab is cut into three pieces each approximately 16 inches long by 24 inches wide.

30. A method according to claim 28 wherein said sod slab is approximately 48 inches long by 48 inches wide, and in said step of cross-cutting, said slab is cut into 4 pieces each approximately 24 inches long by 24 inches wide.

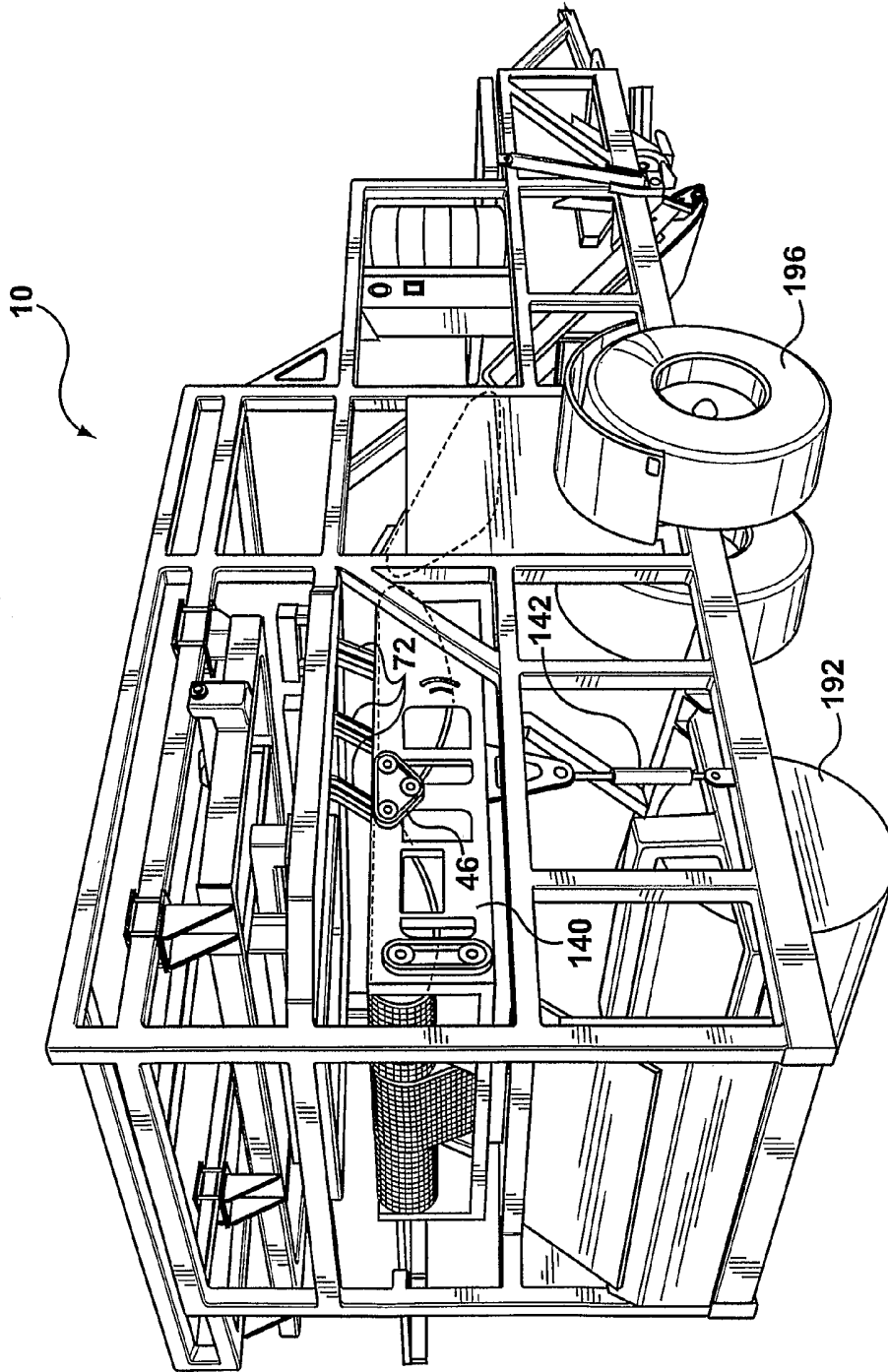

FIG. 1

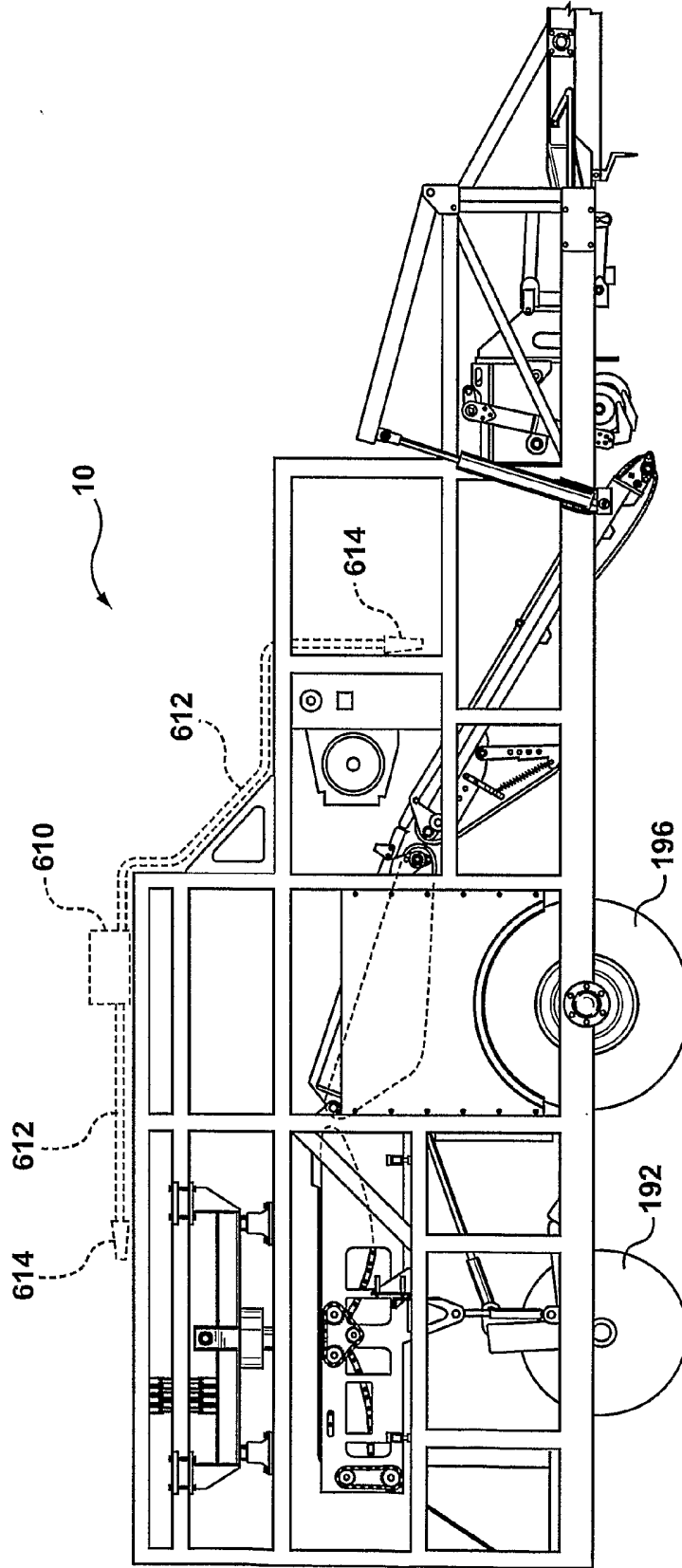

FIG. 2

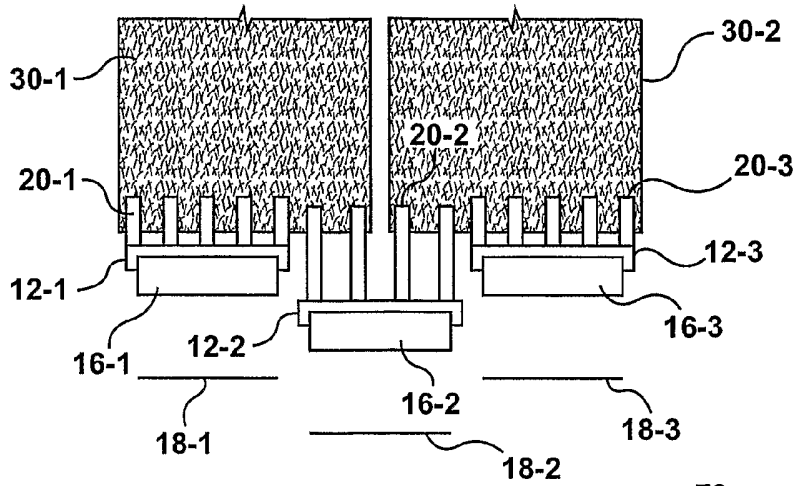

FIG. 3

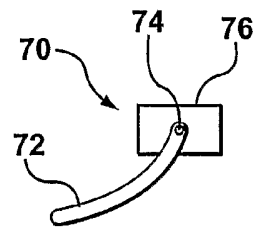

FIG. 5

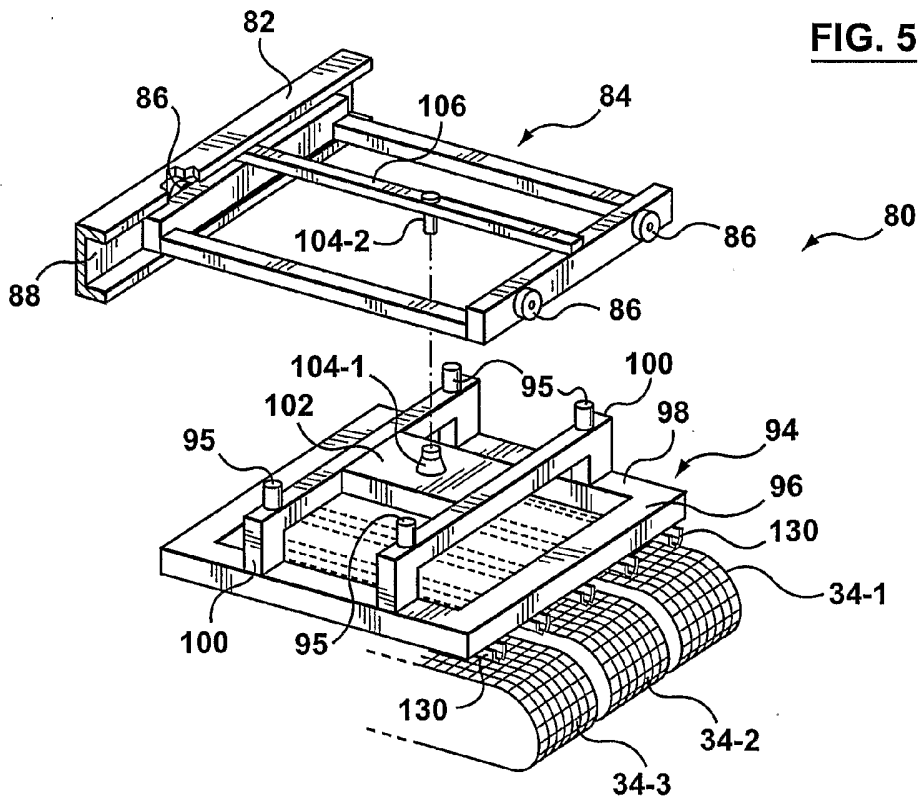

FIG. 6

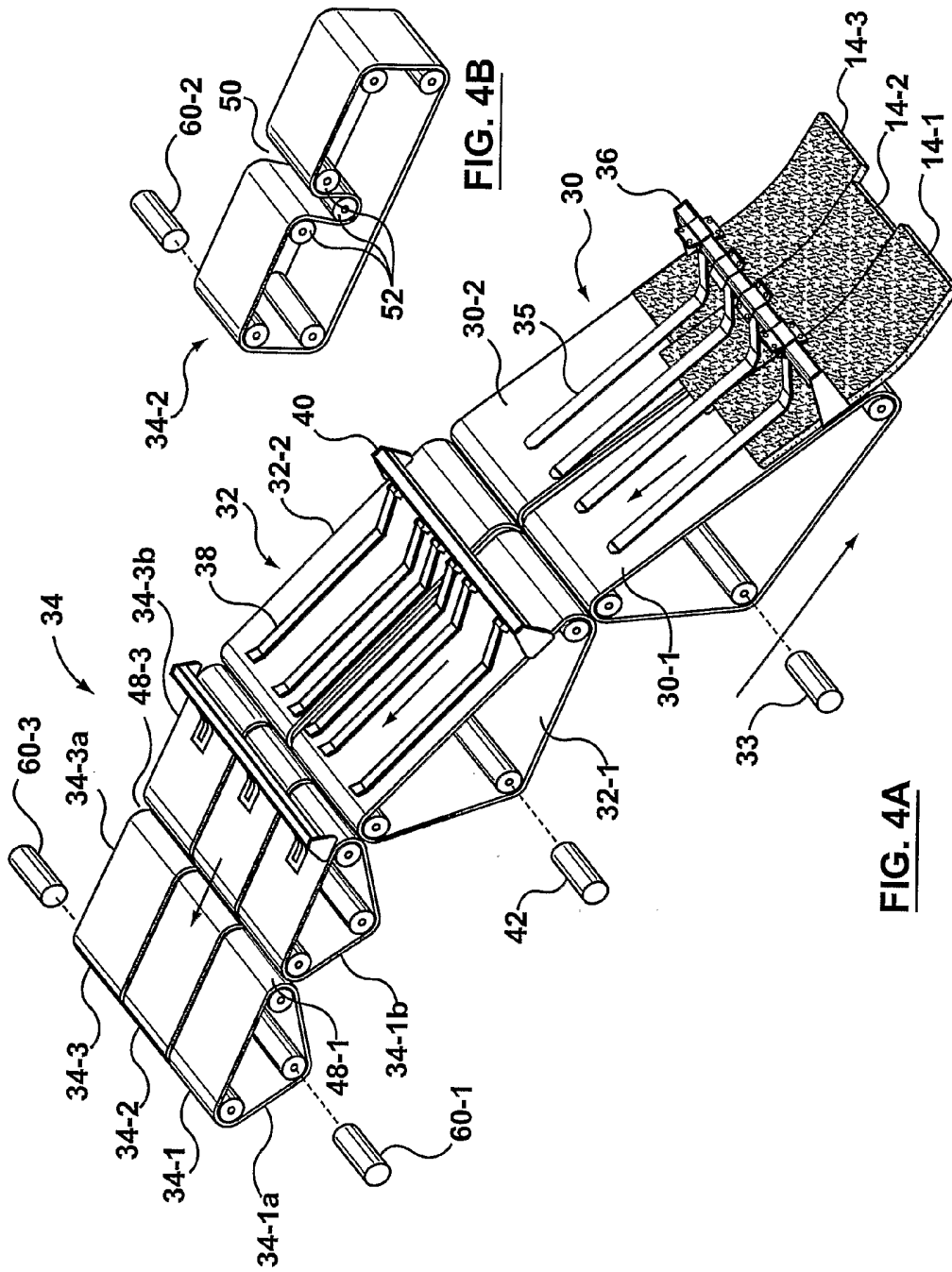

FIG. 4B

FIG. 4A

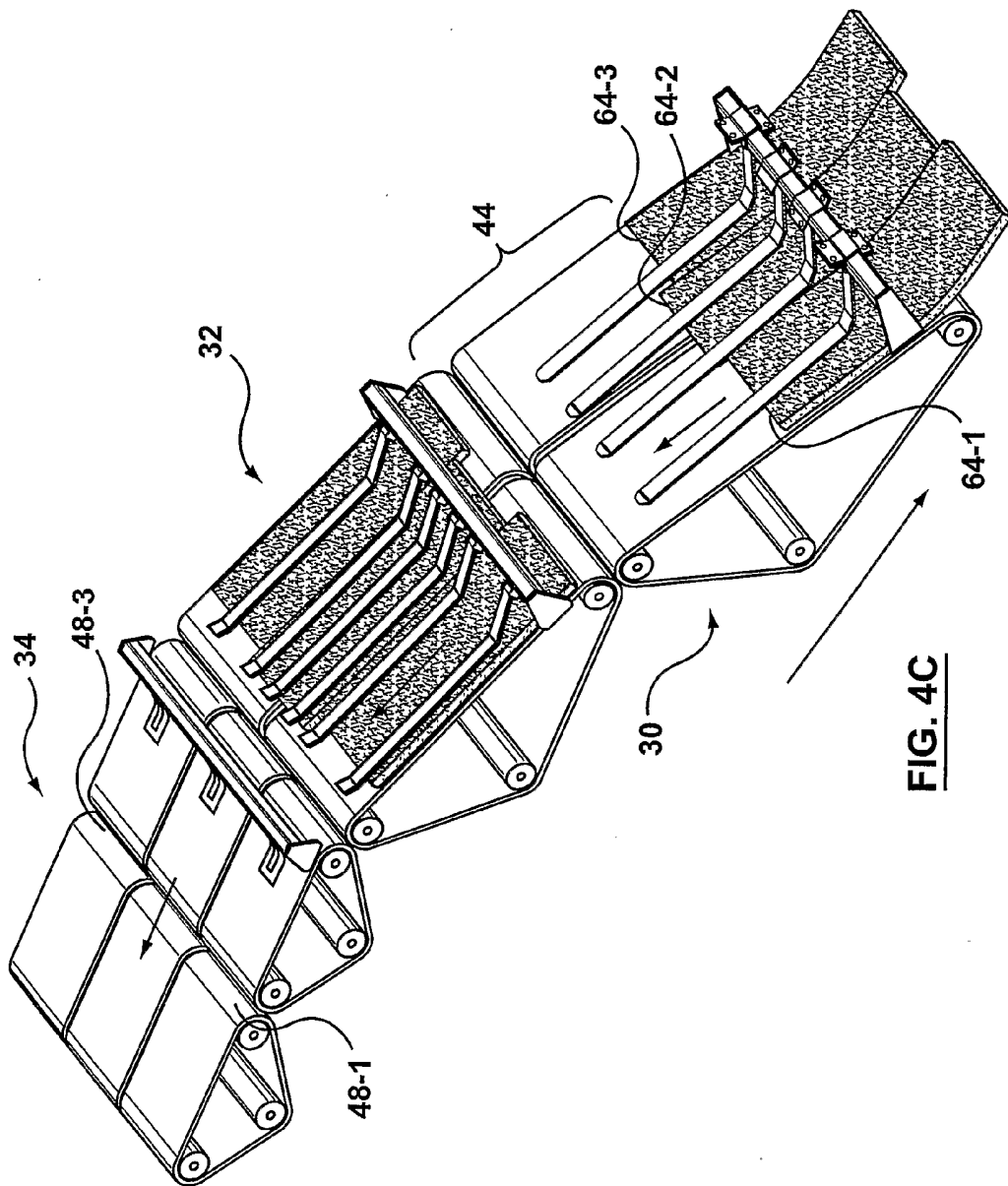

FIG. 4C

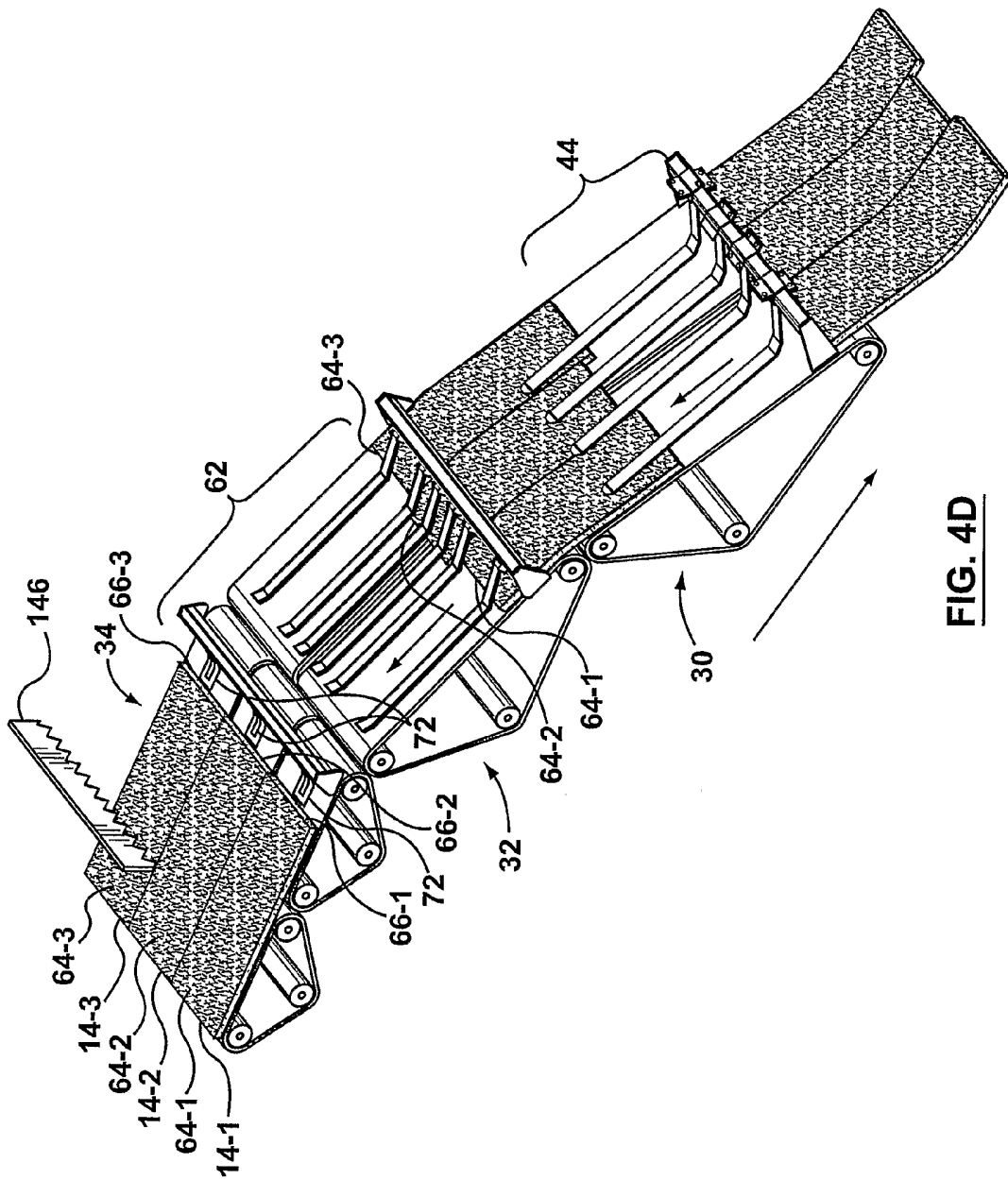

FIG. 4D

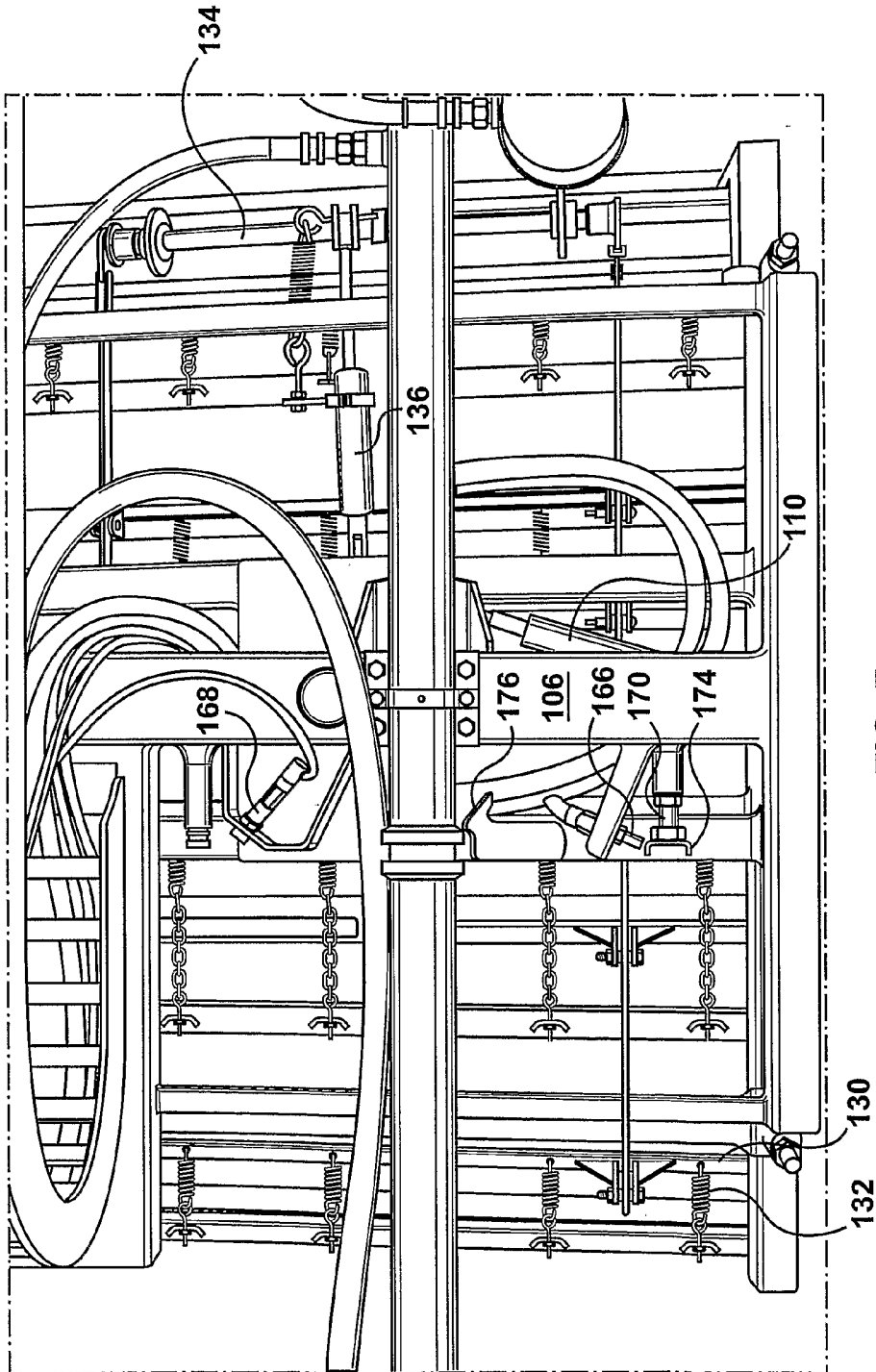

FIG. 7

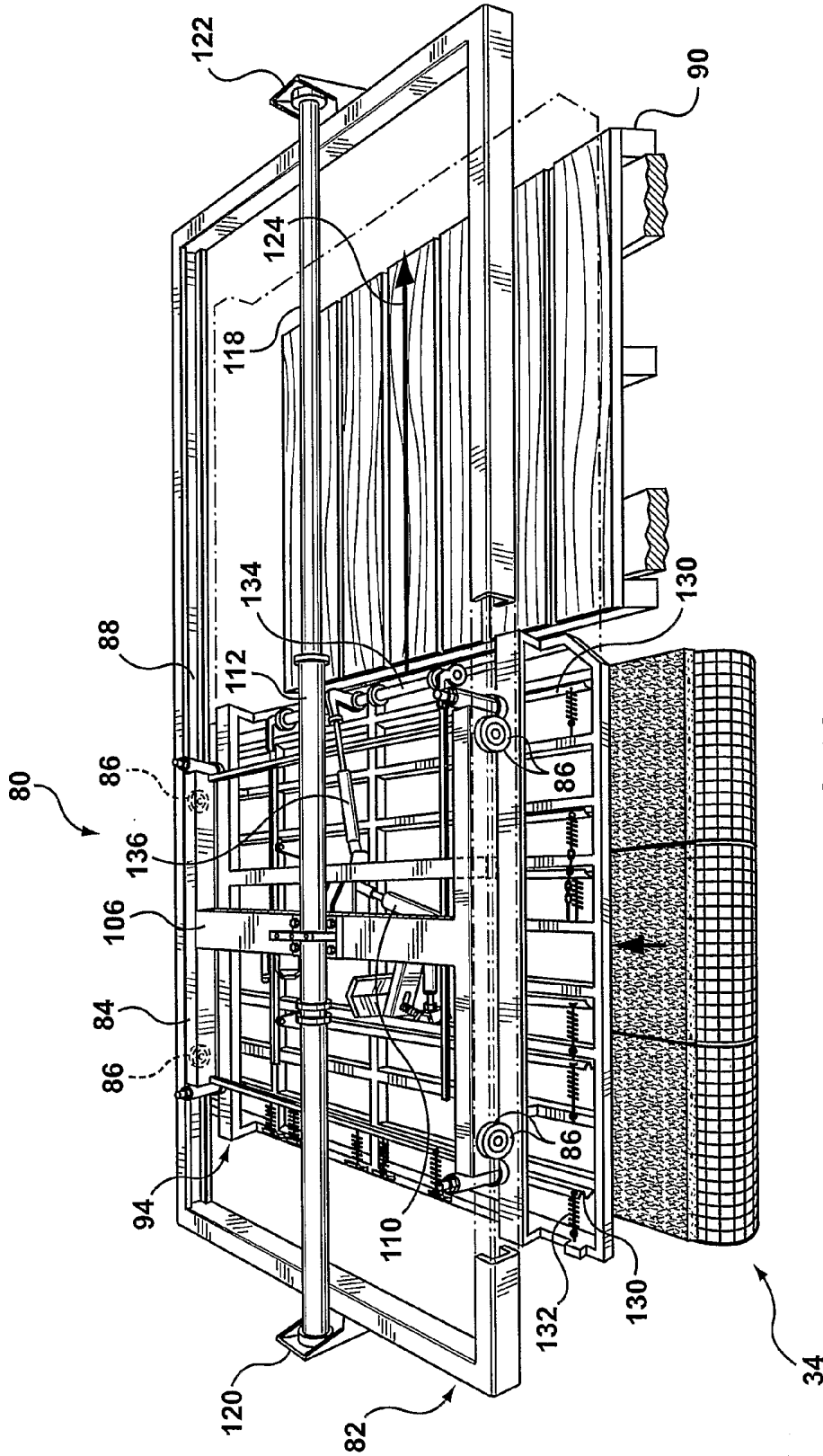

FIG. 8A

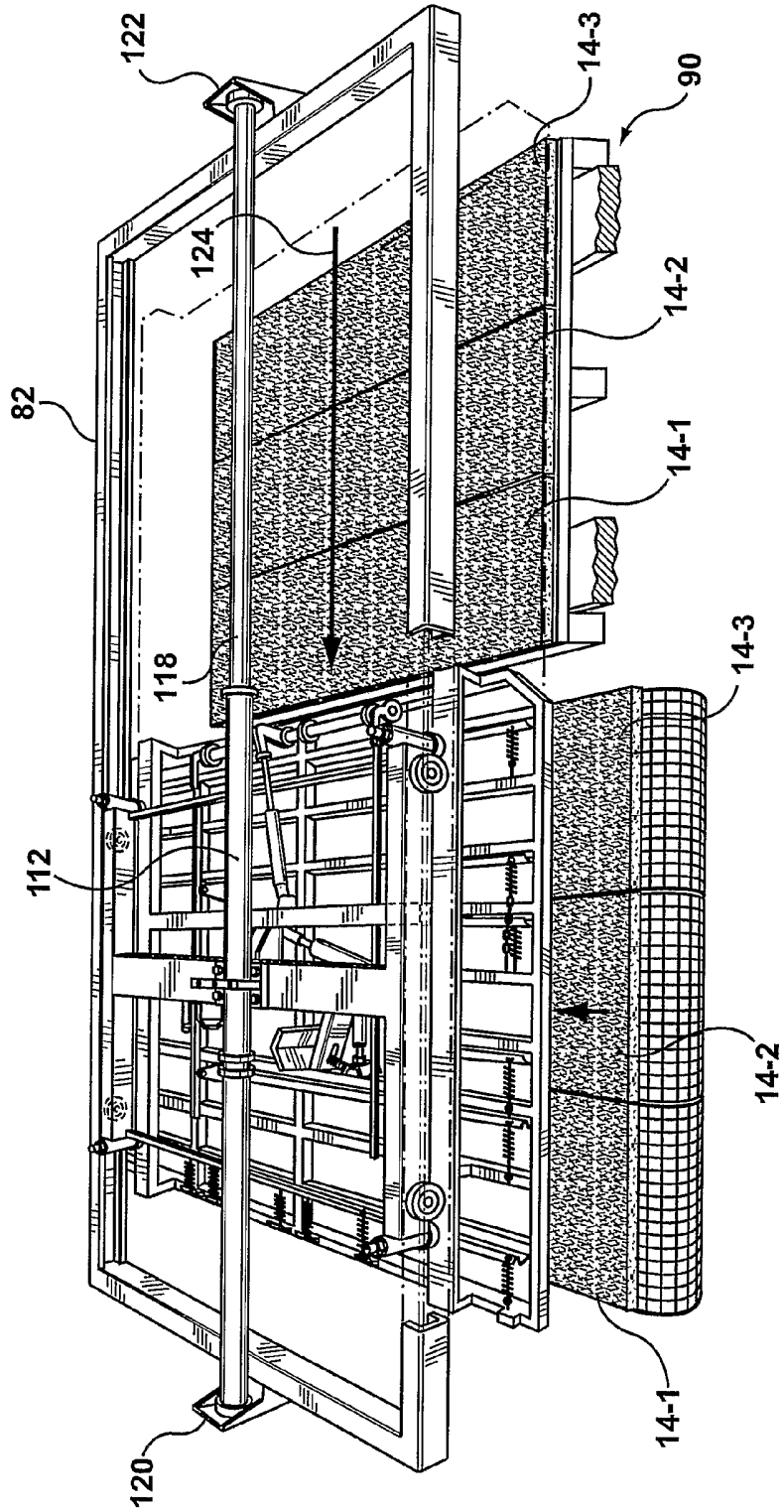

FIG. 8B

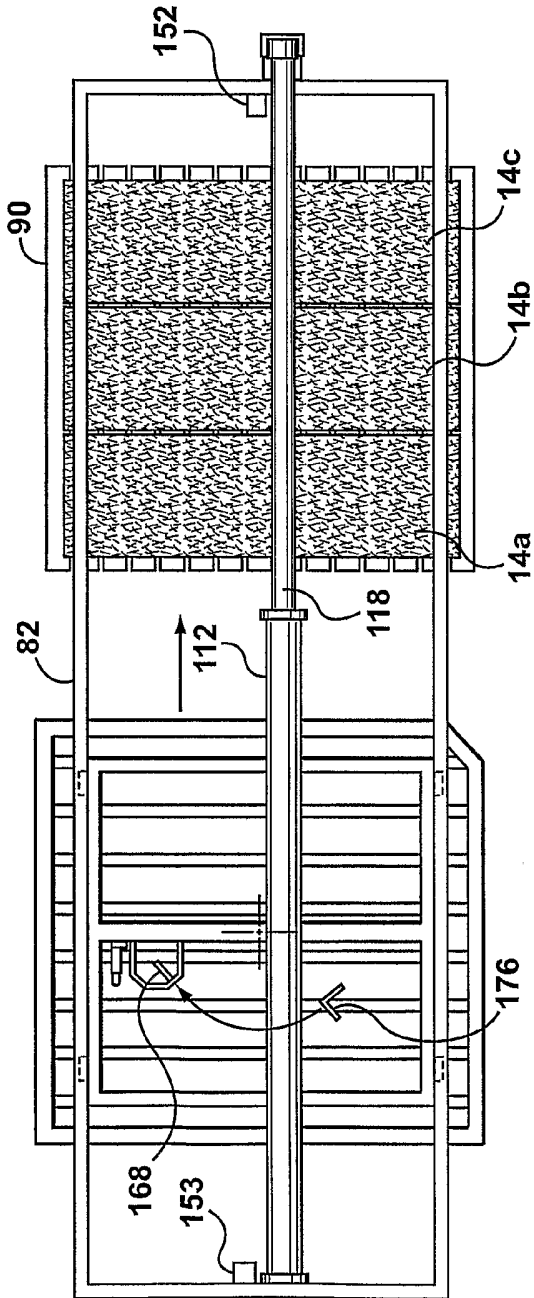

FIG. 9A

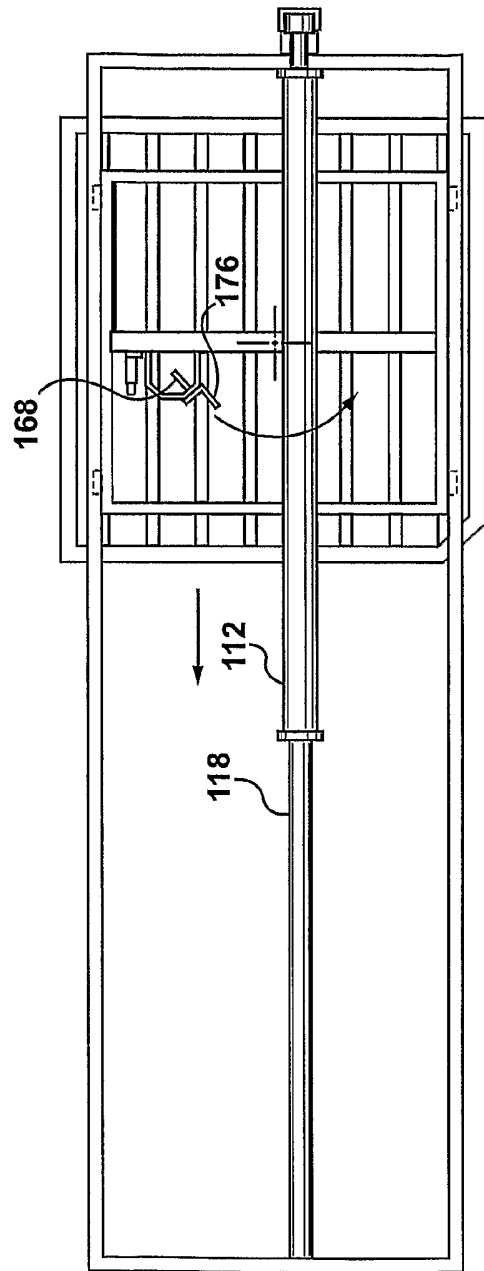

FIG. 9B

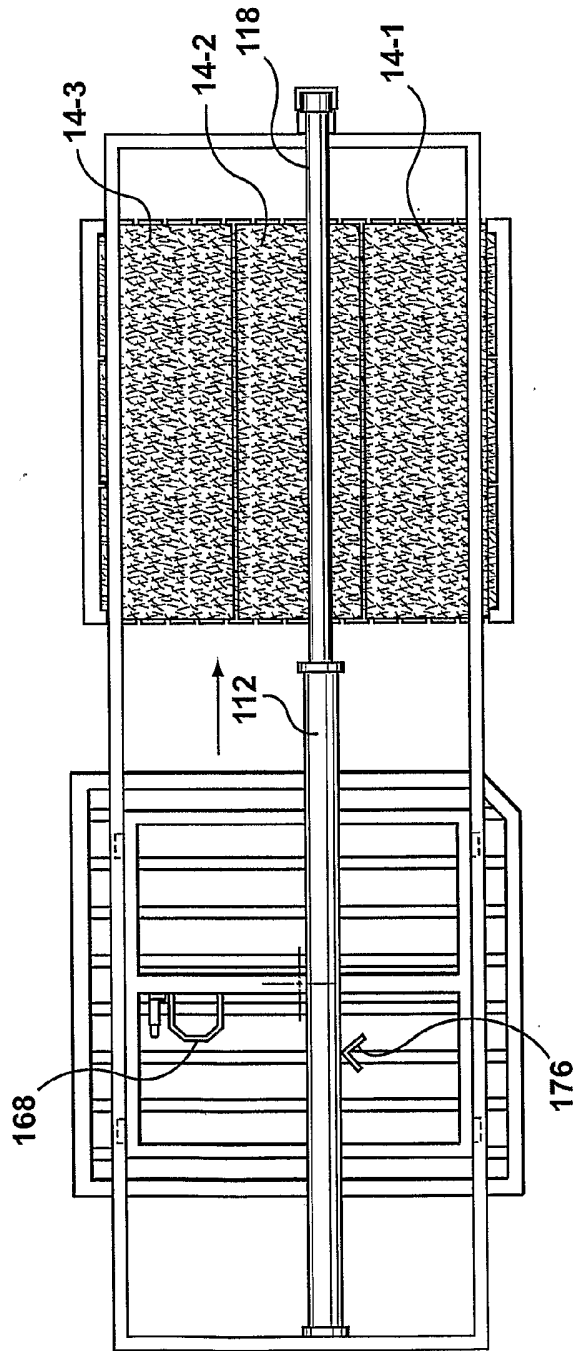

FIG. 9C

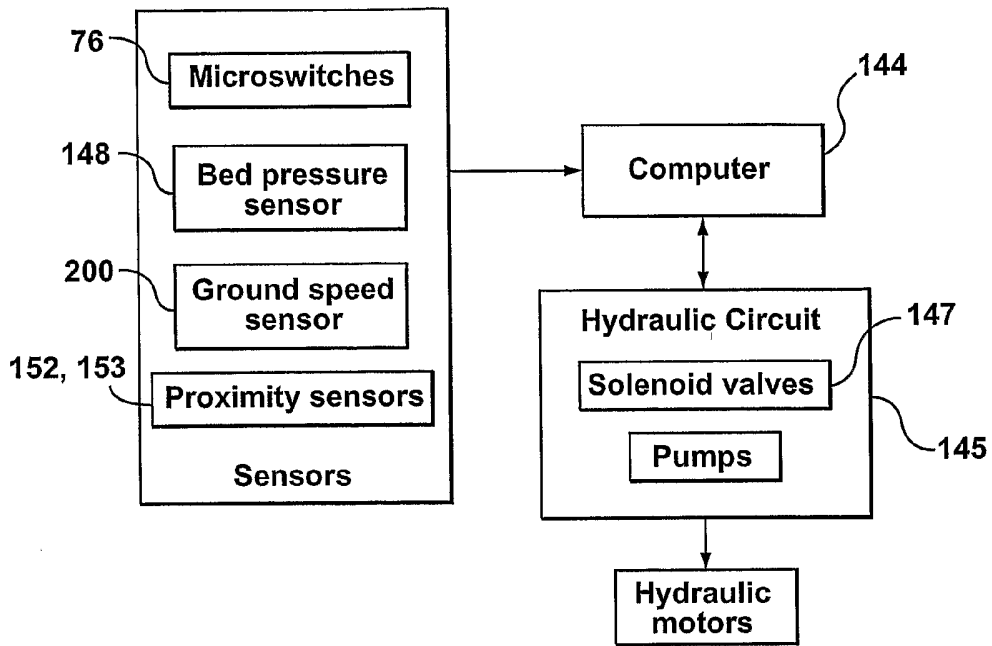

FIG. 10

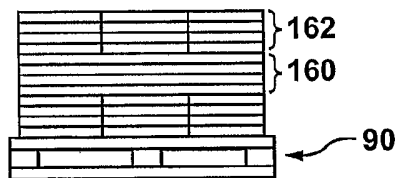

FIG. 12

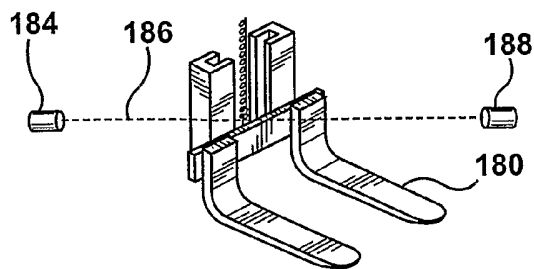

FIG. 15

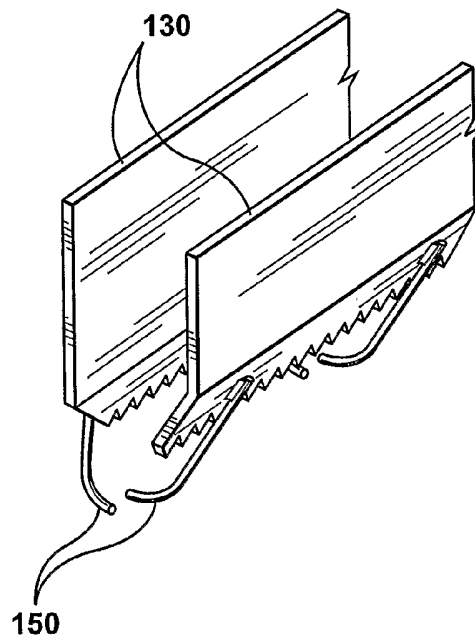

FIG. 11

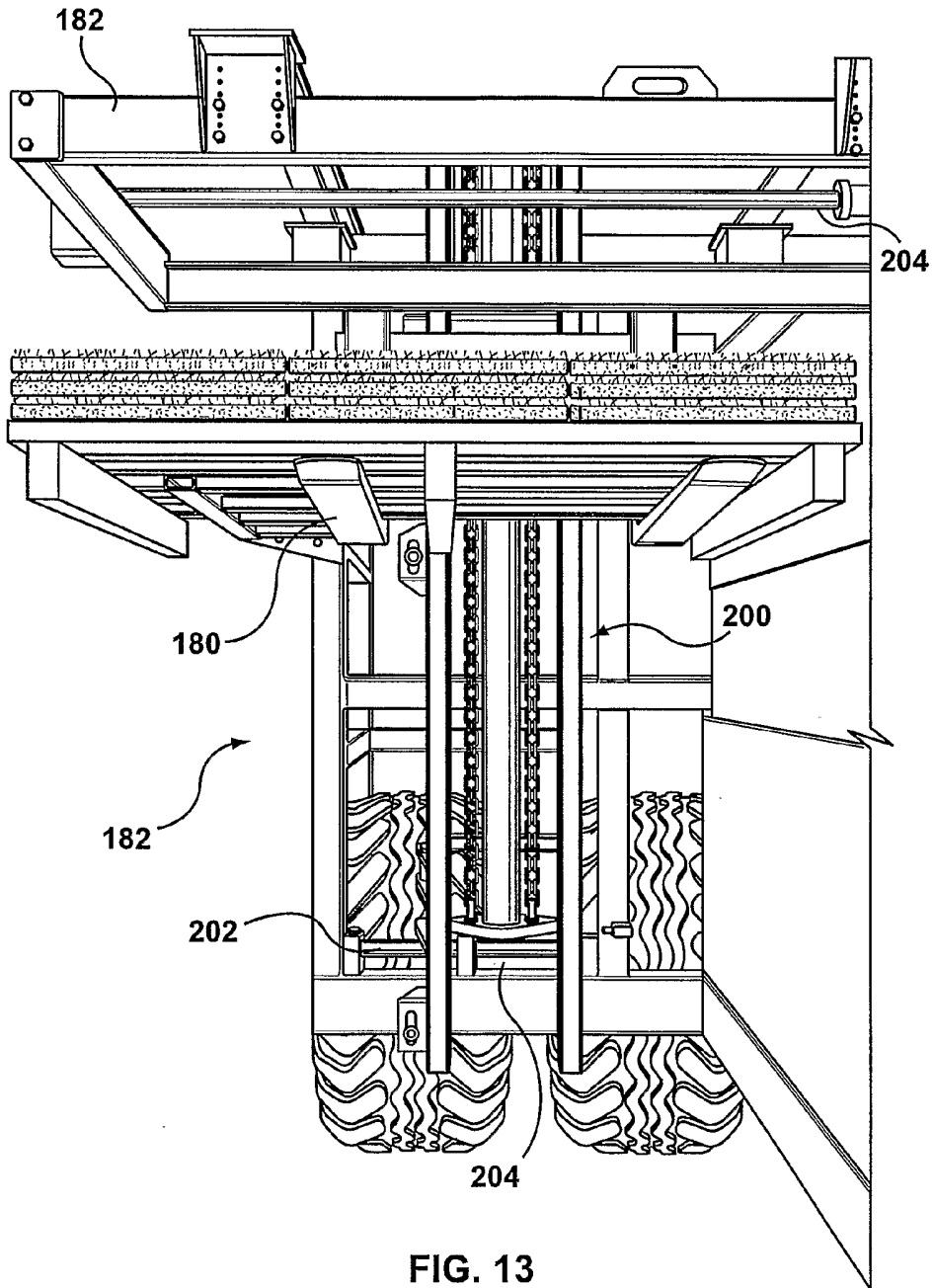

FIG. 13

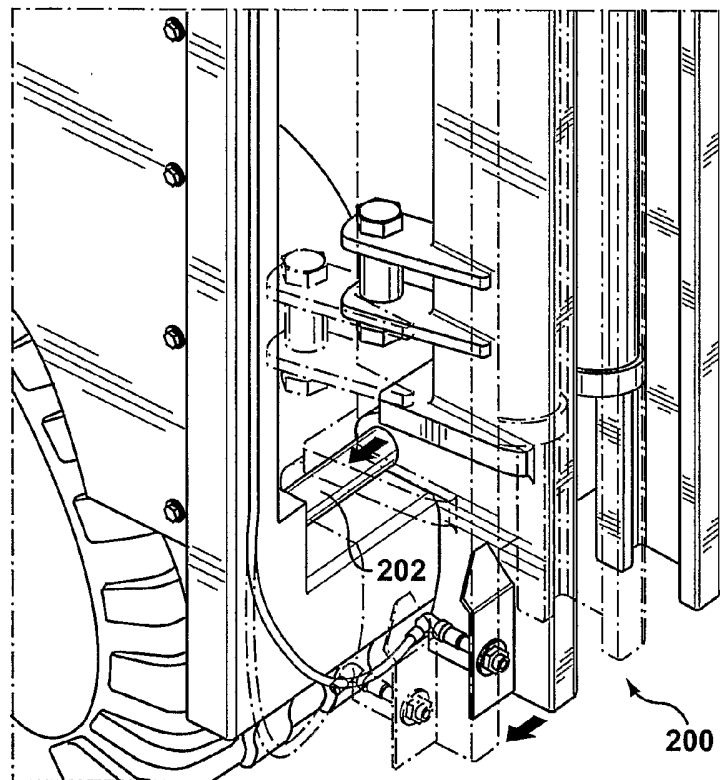

FIG. 14

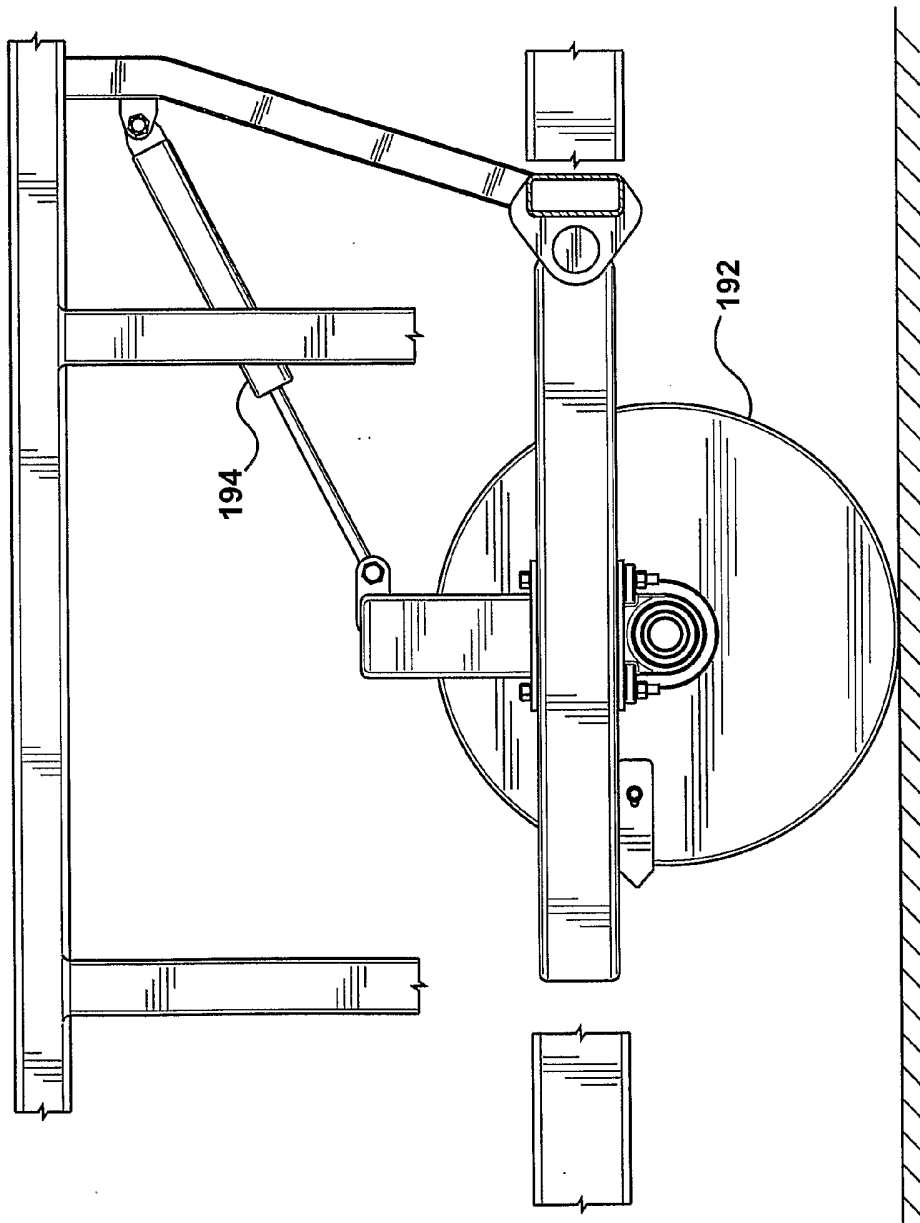

FIG. 16

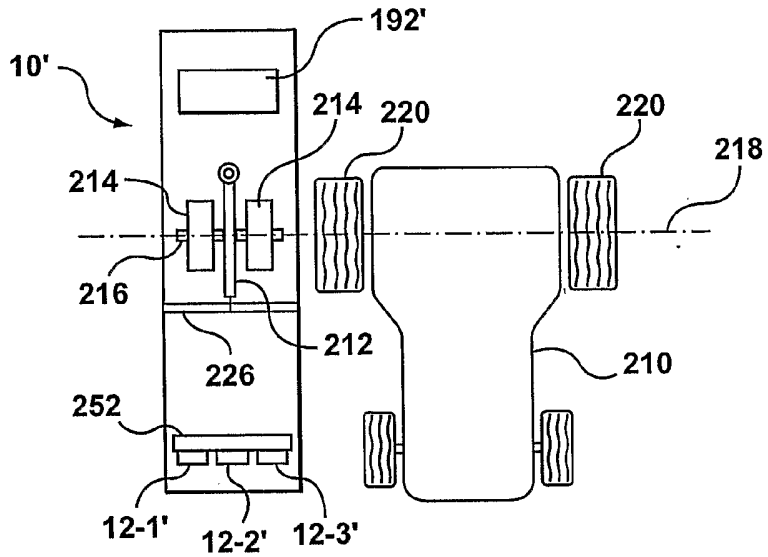

FIG. 17

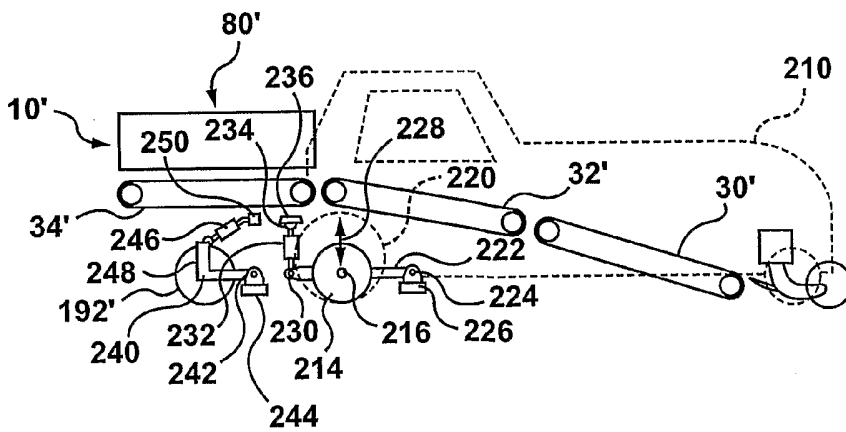

FIG. 18

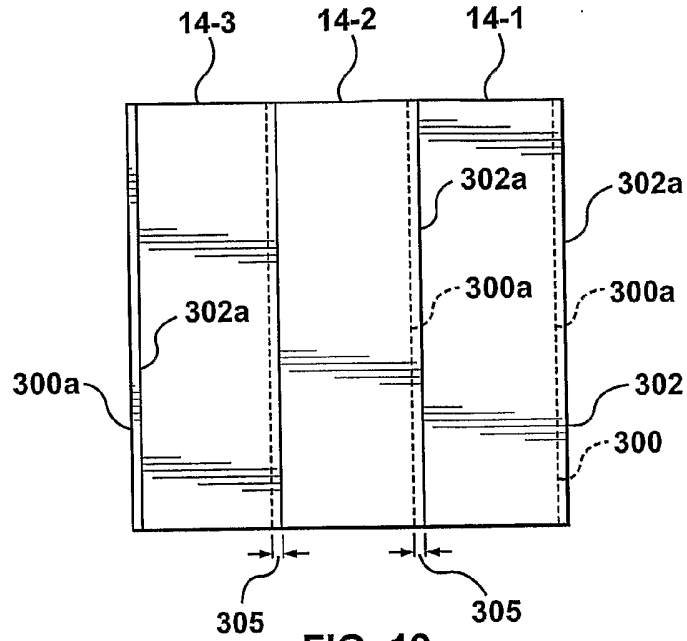

FIG. 19

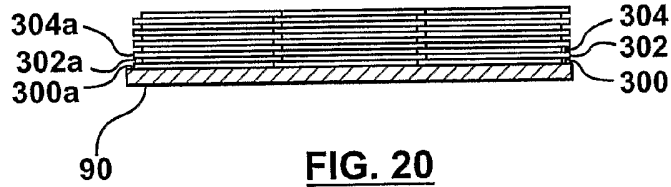

FIG. 20

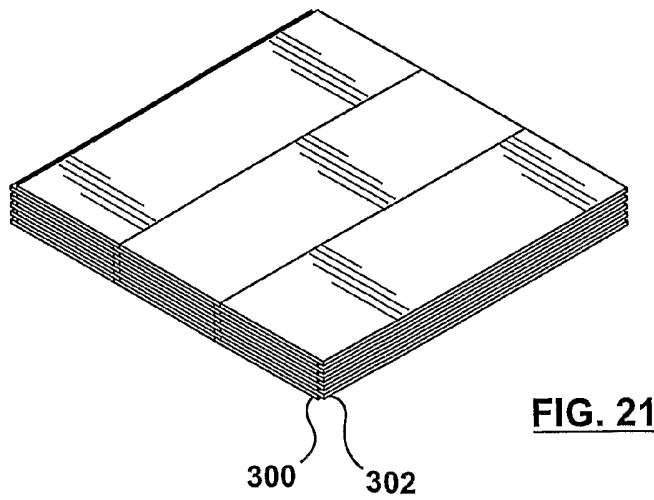

FIG. 21

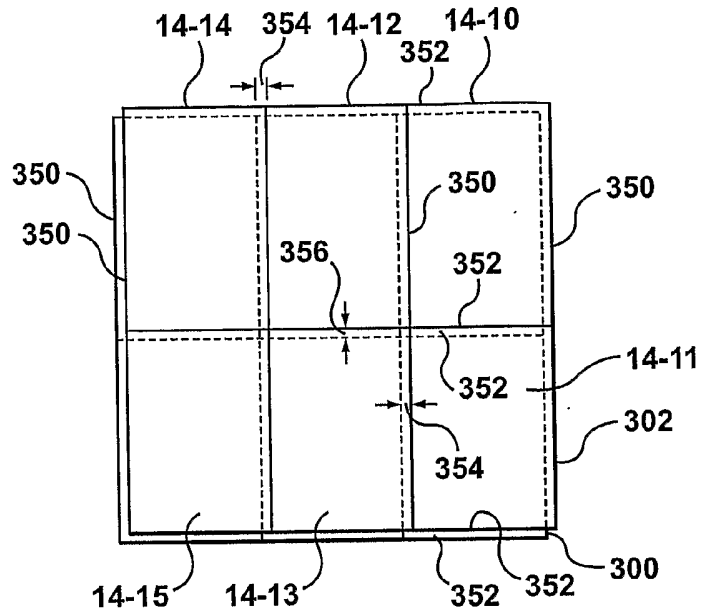

FIG. 22

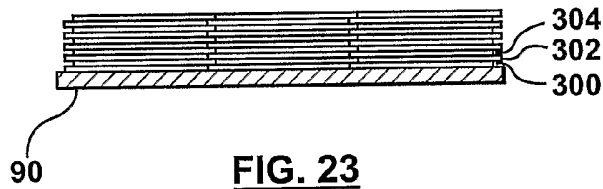

FIG. 23

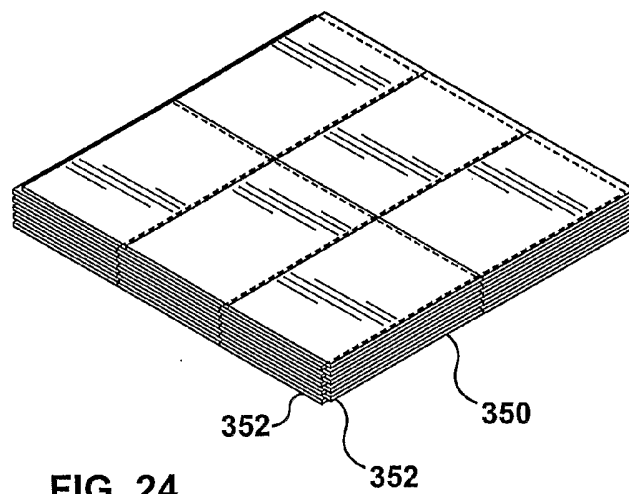

FIG. 24

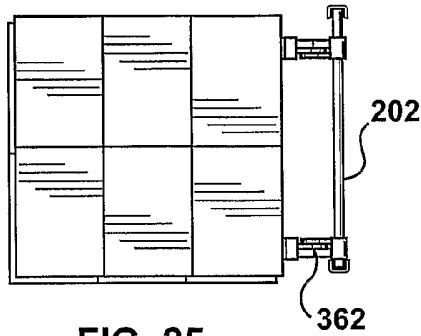

FIG. 25

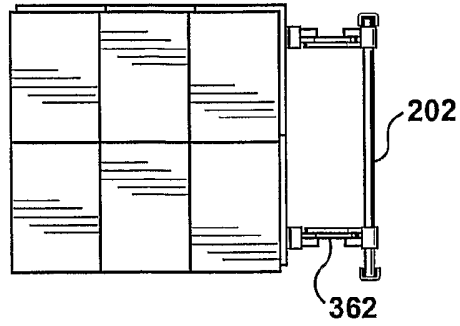

FIG. 27

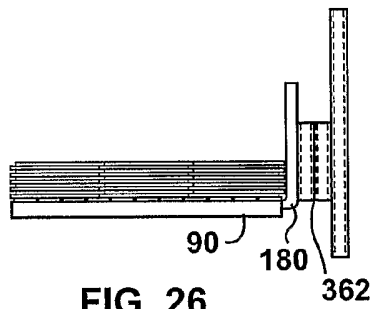

FIG. 26

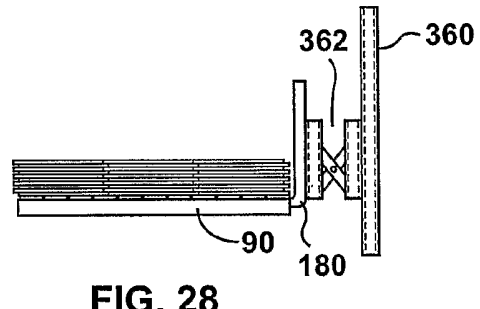

FIG. 28

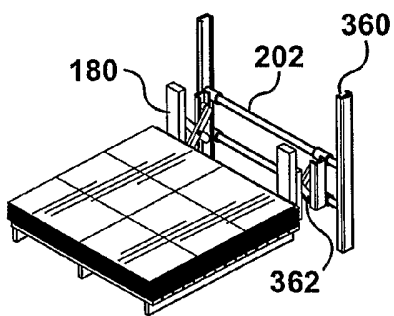

FIG. 29

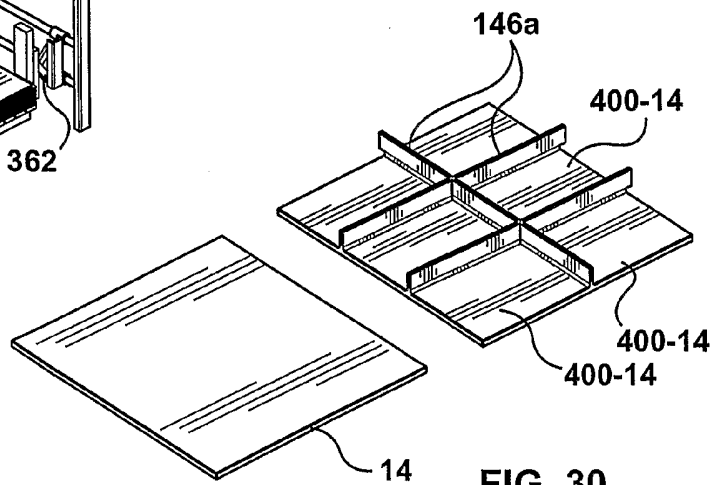

FIG. 30

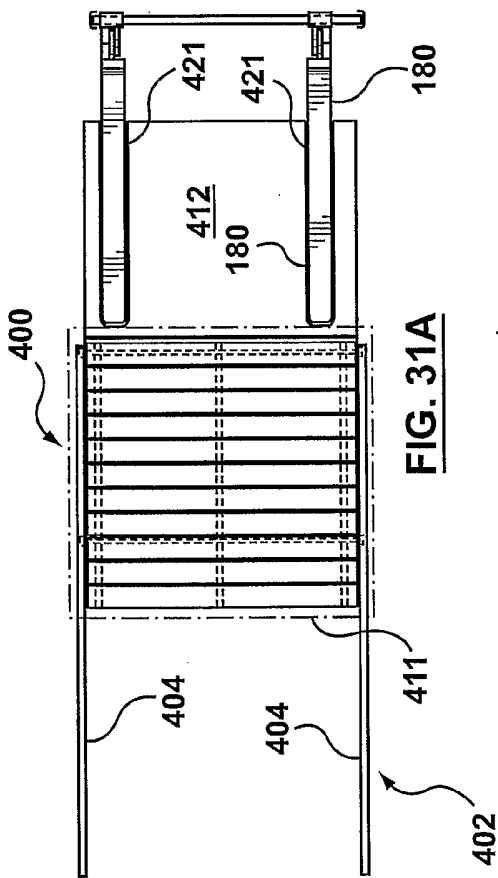

FIG. 31A

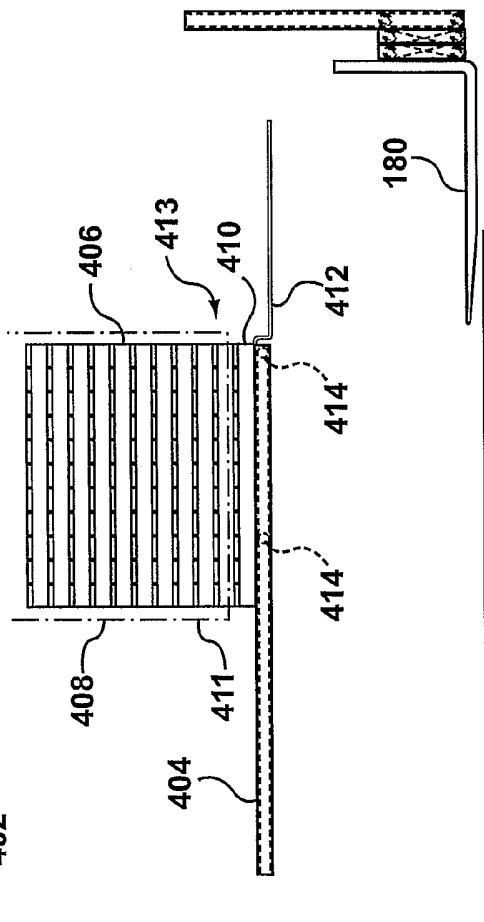

FIG. 31B

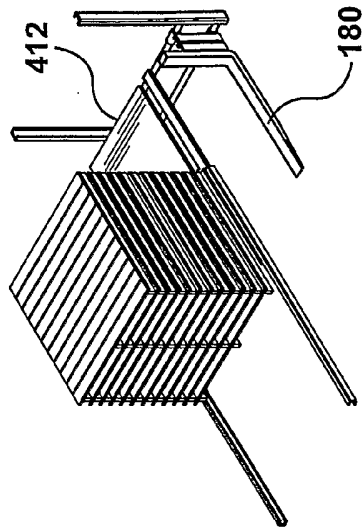

FIG. 31C

22/35

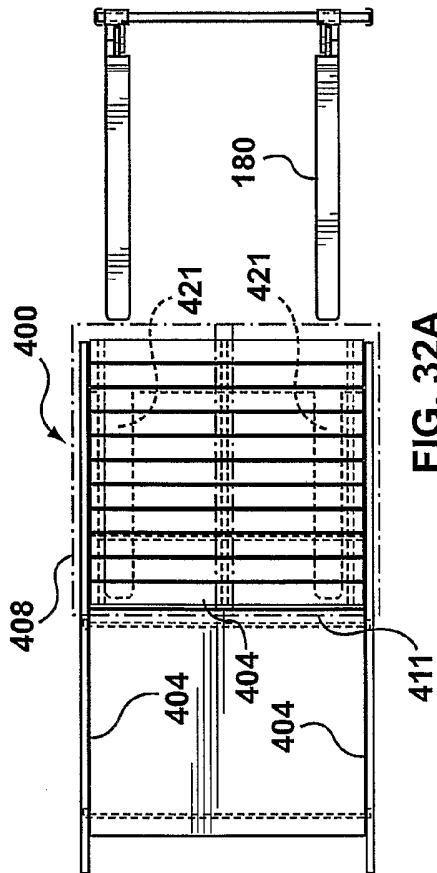

FIG. 32A

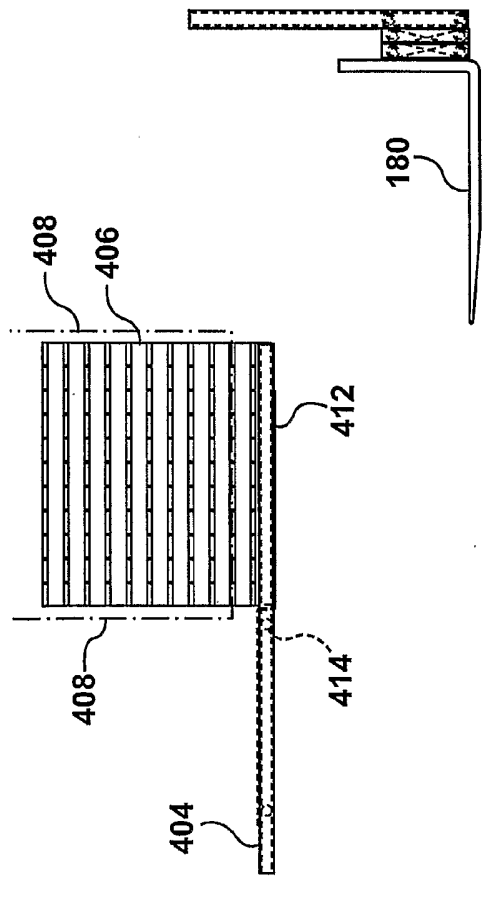

FIG. 32B

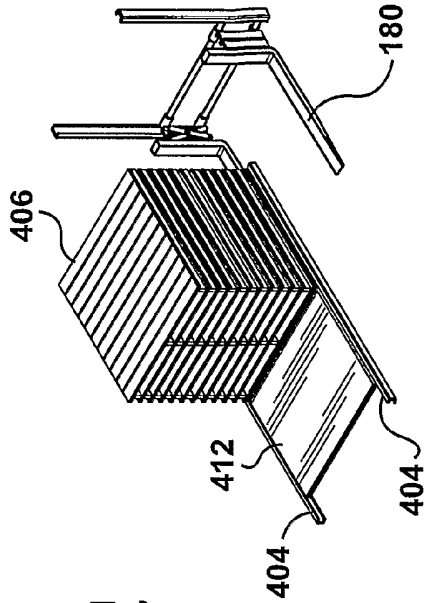

FIG. 32C

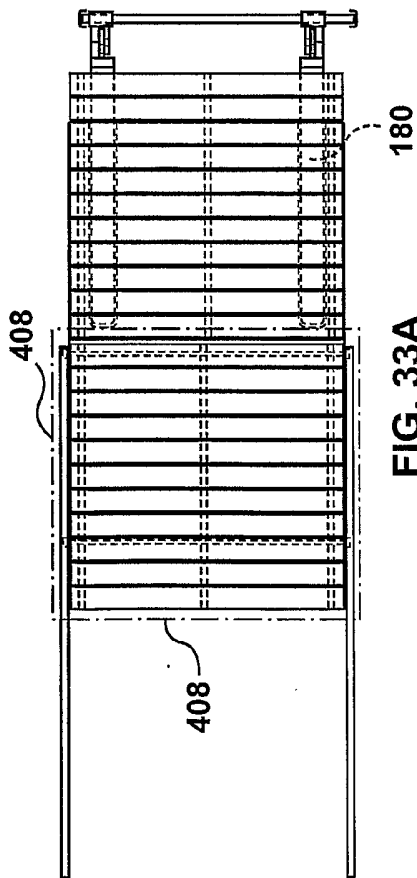

FIG. 33A

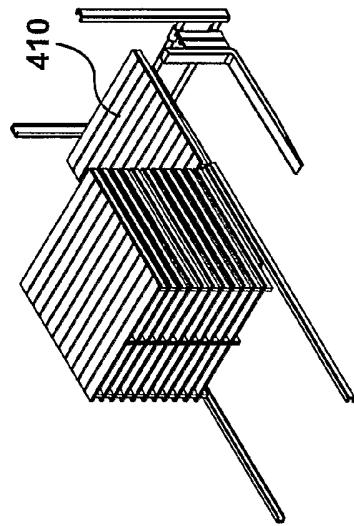

FIG. 33C

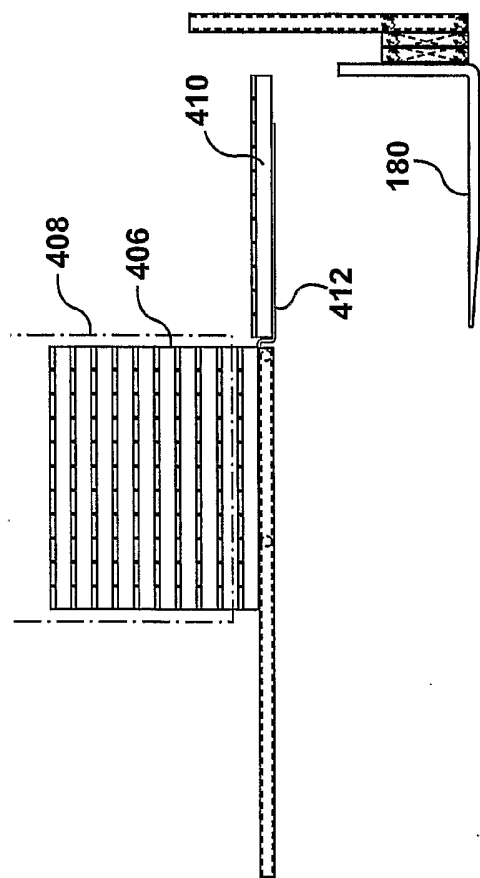

FIG. 33B

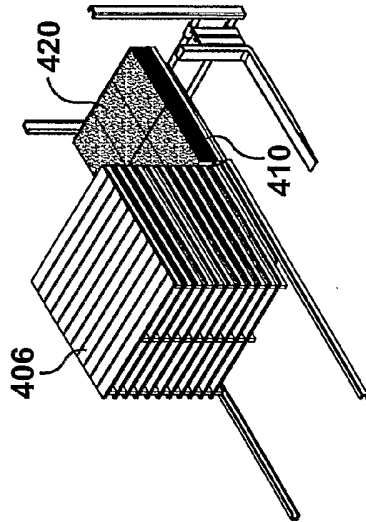

FIG. 34C

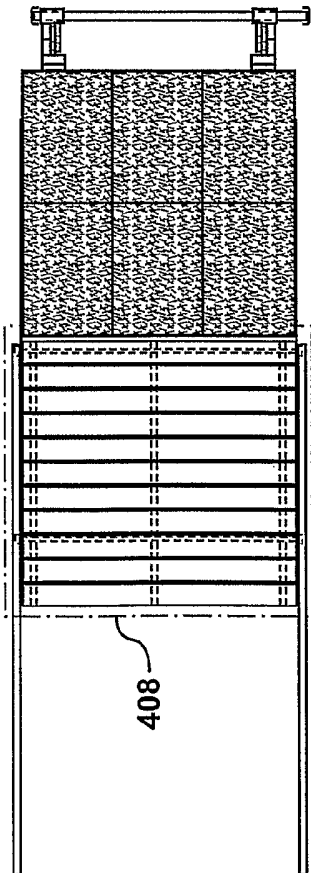

FIG. 34A

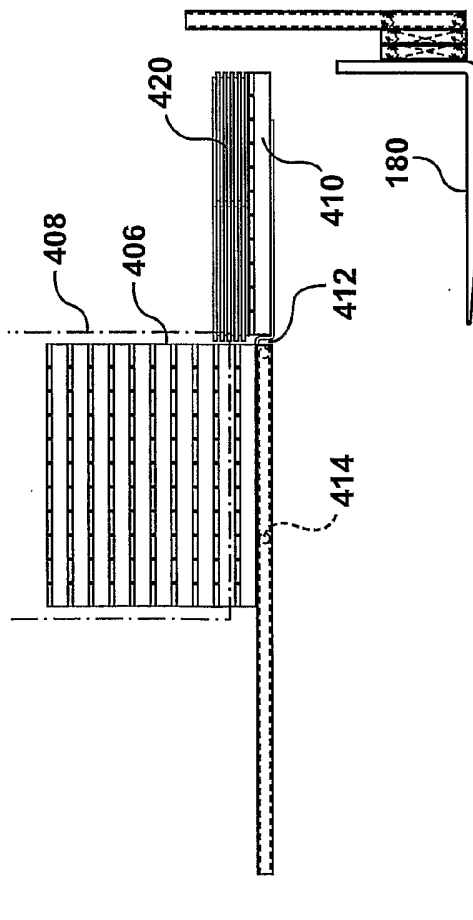

FIG. 34B

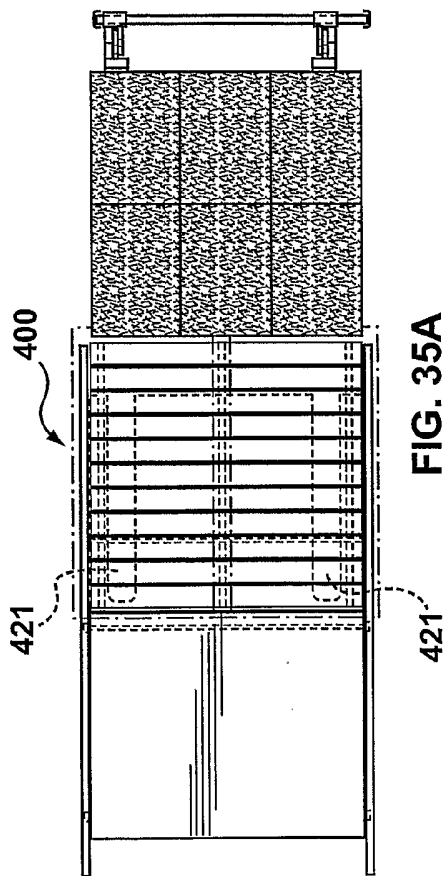

FIG. 35A

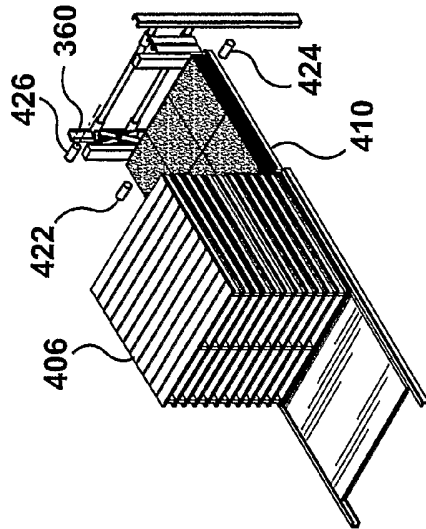

FIG. 35C

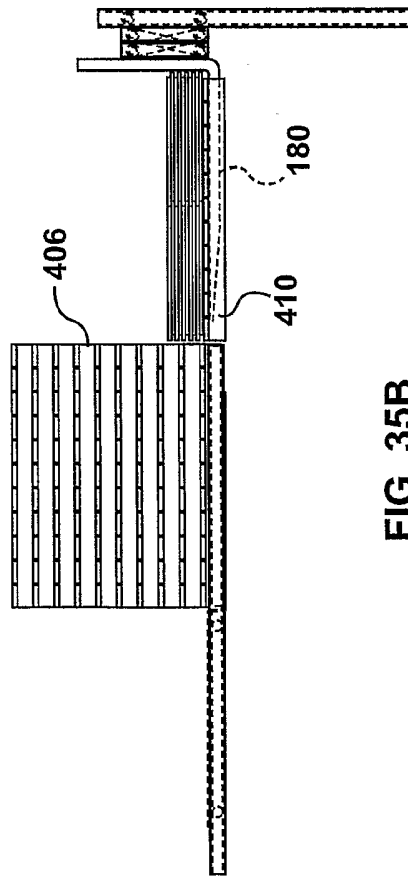

FIG. 35B

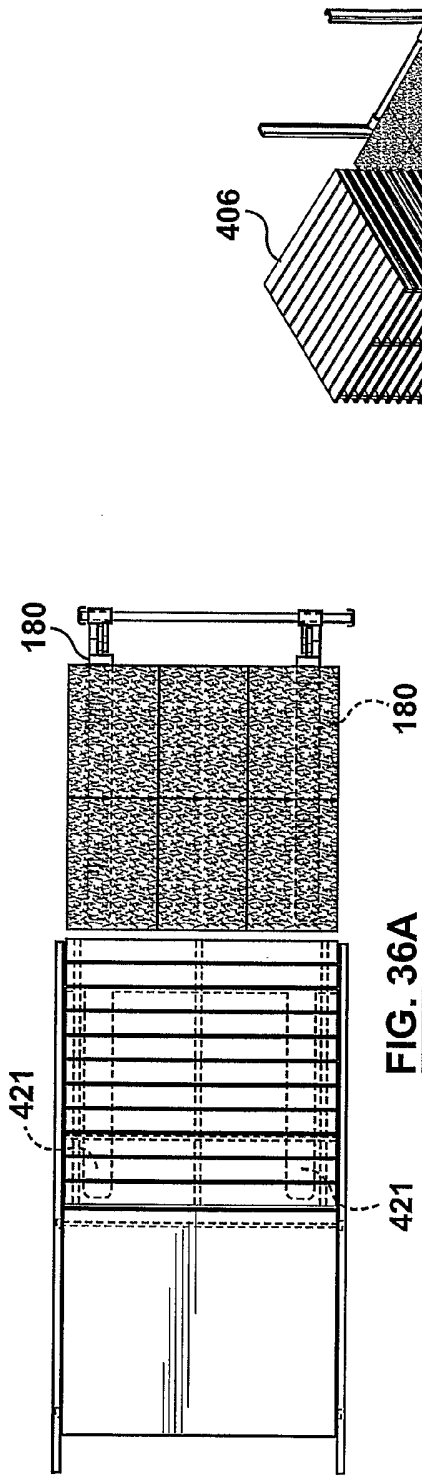

FIG. 36A

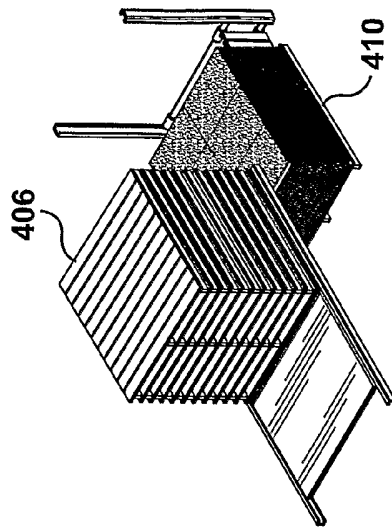

FIG. 36C

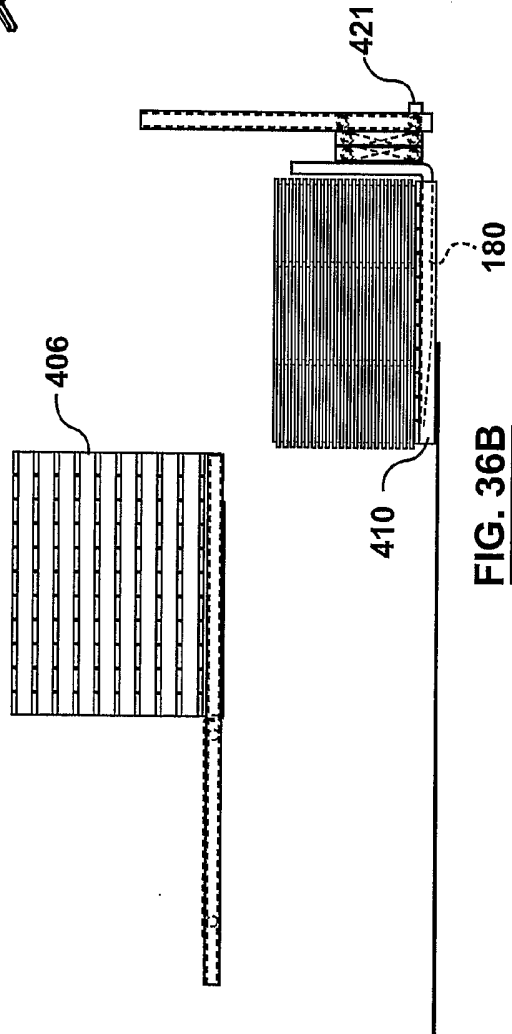

FIG. 36B

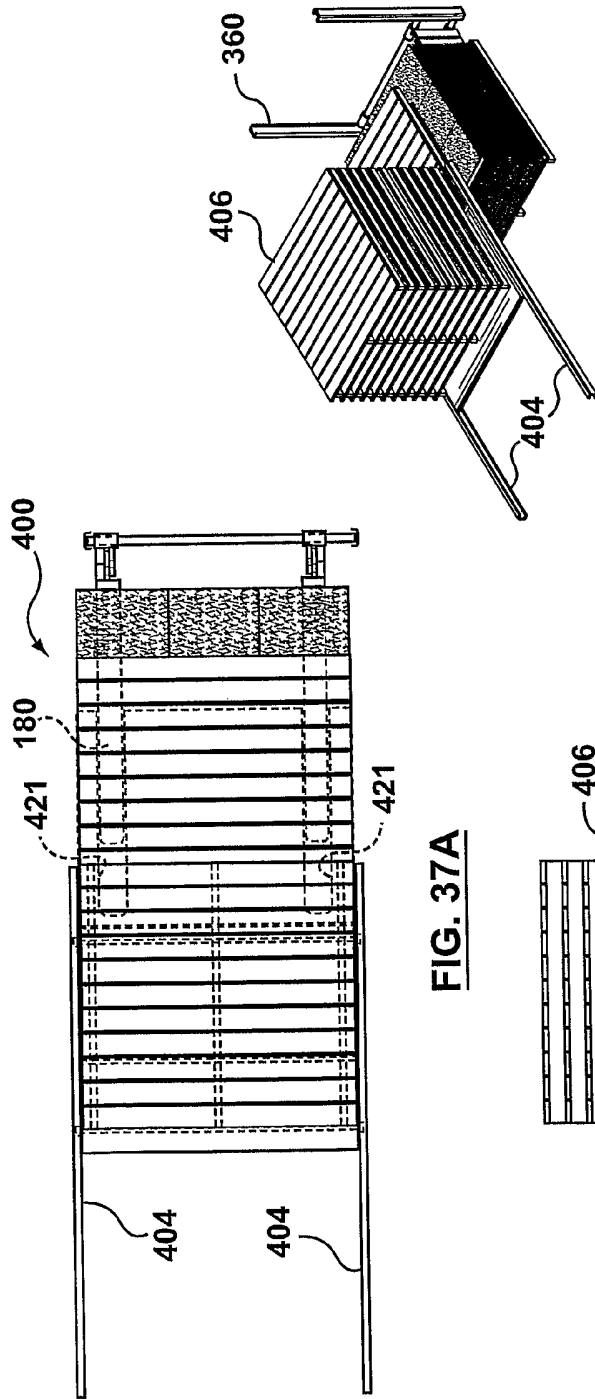

FIG. 37A

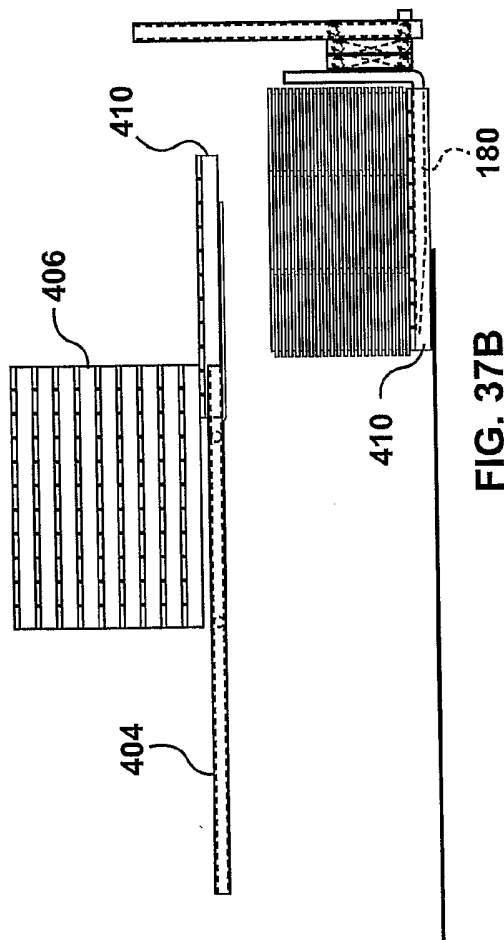

FIG. 37B

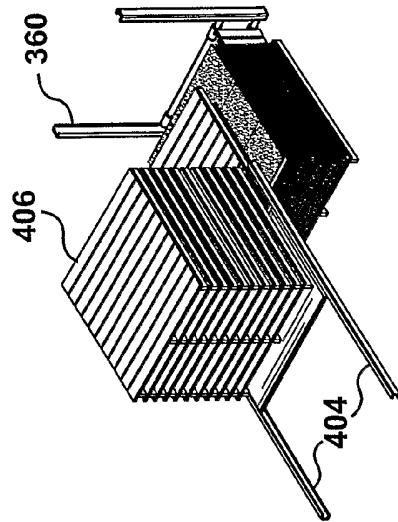

FIG. 37C

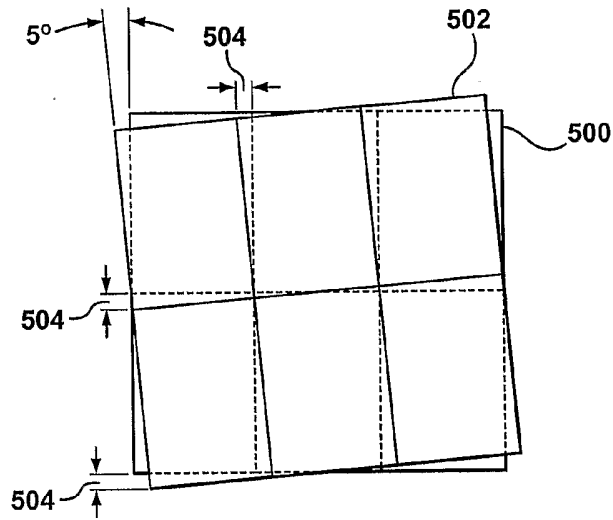

FIG. 38

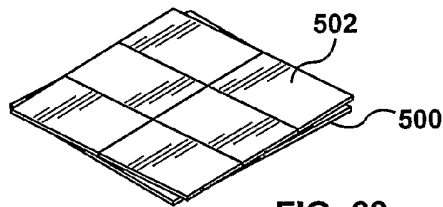

FIG. 39

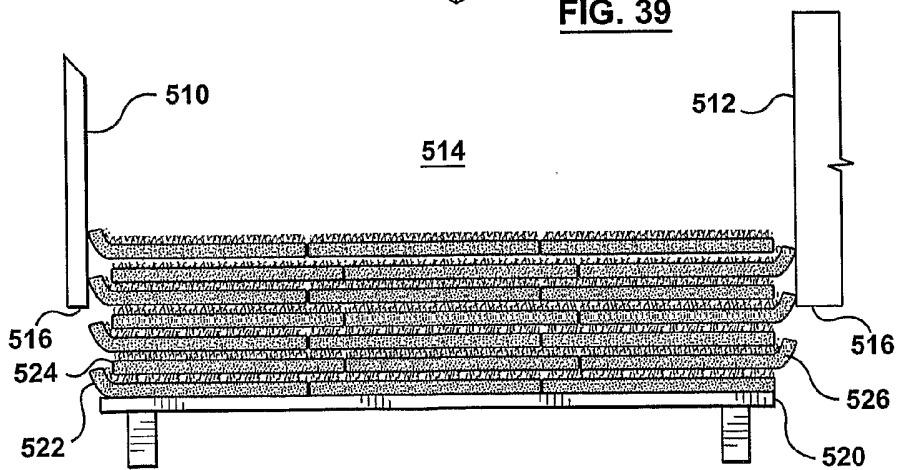

FIG. 40

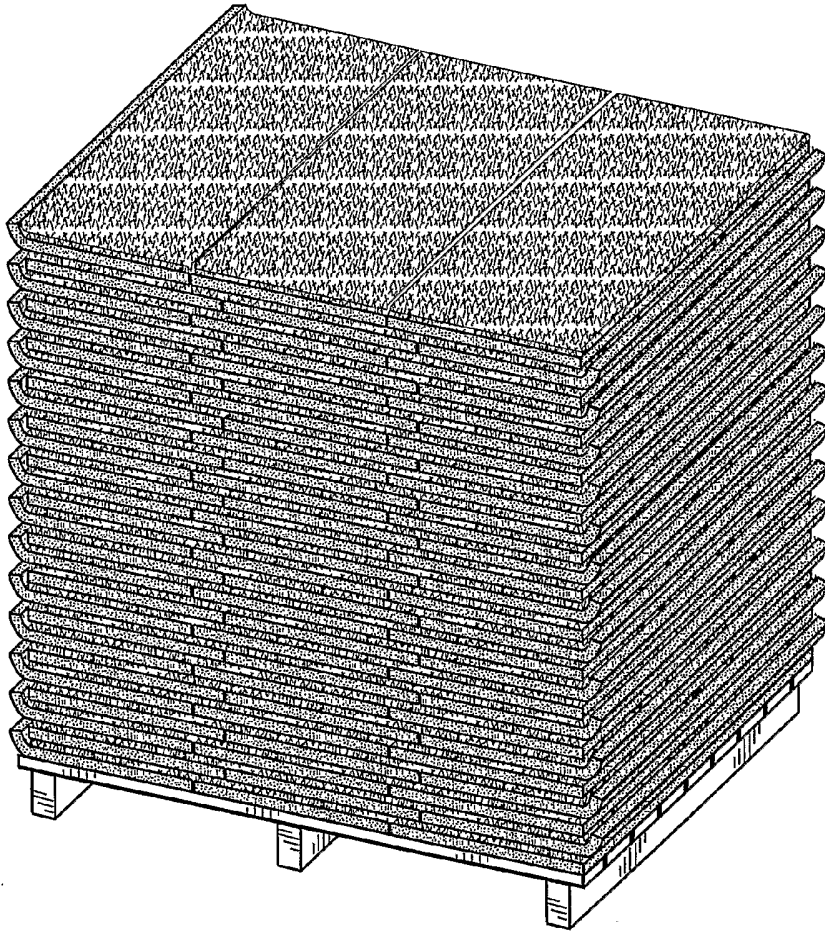

FIG. 41

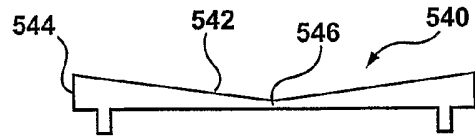

FIG. 42A

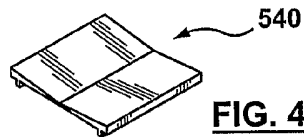

FIG. 42B

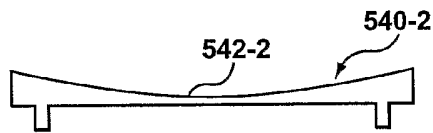

FIG. 43A

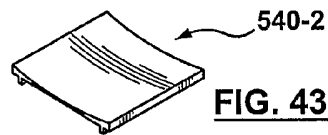

FIG. 43B

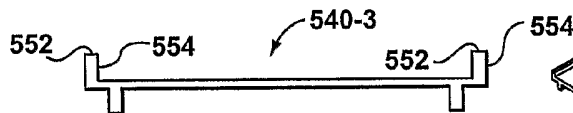

FIG. 44A

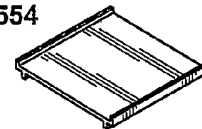

FIG. 44B

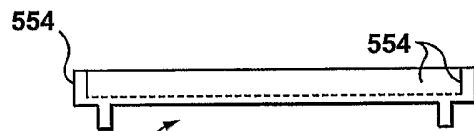

FIG. 45A

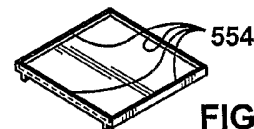

FIG. 45B

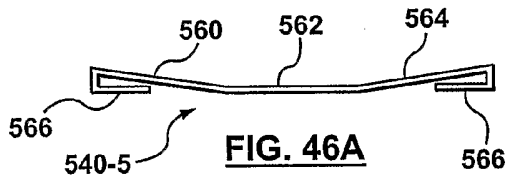

FIG. 46A

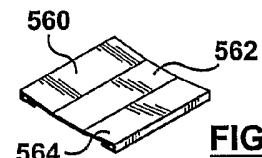

FIG. 46B



FIG. 47A

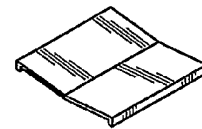

FIG. 47B

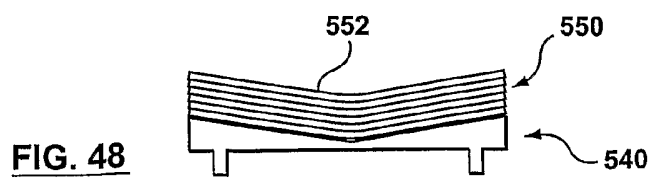

FIG. 48

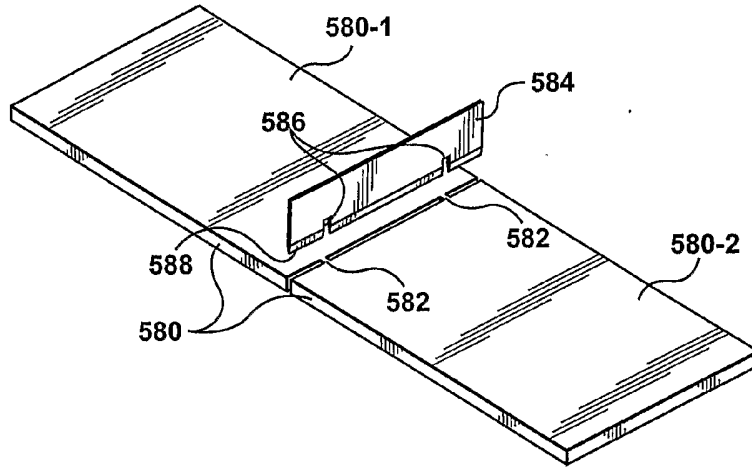

FIG. 49

FIG. 50A

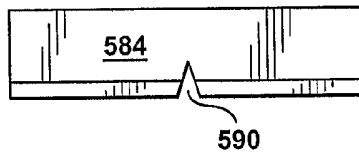

FIG. 50B

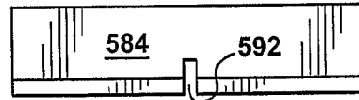

FIG. 50C

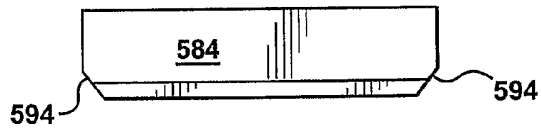
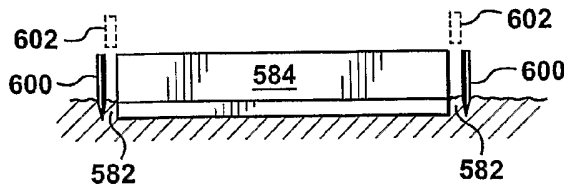

FIG. 50D



FIG. 50E



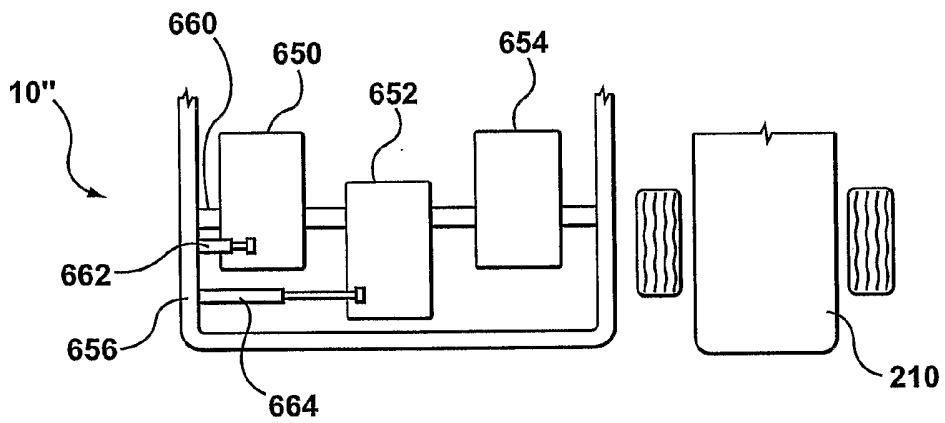

FIG. 51

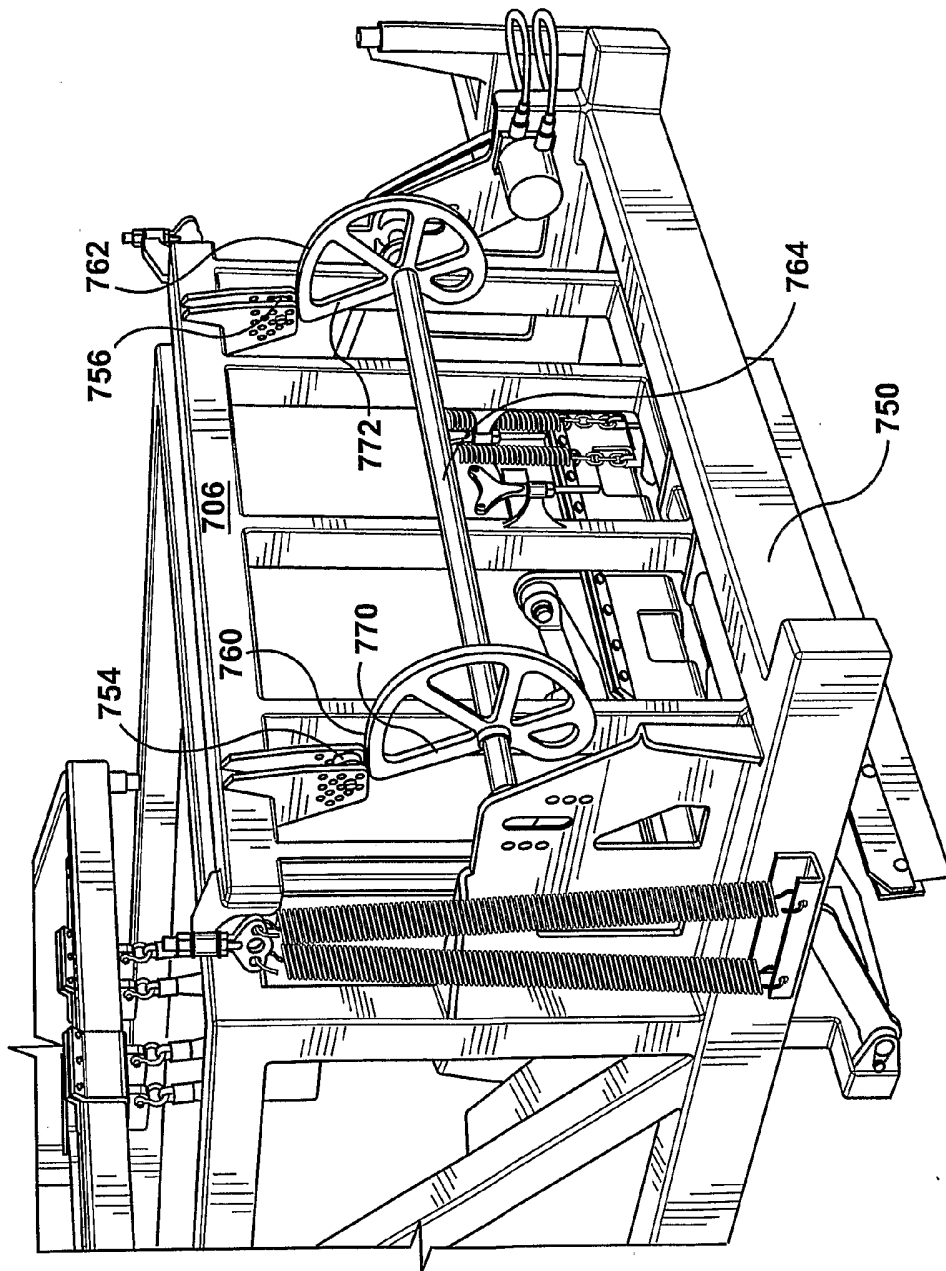

FIG. 52

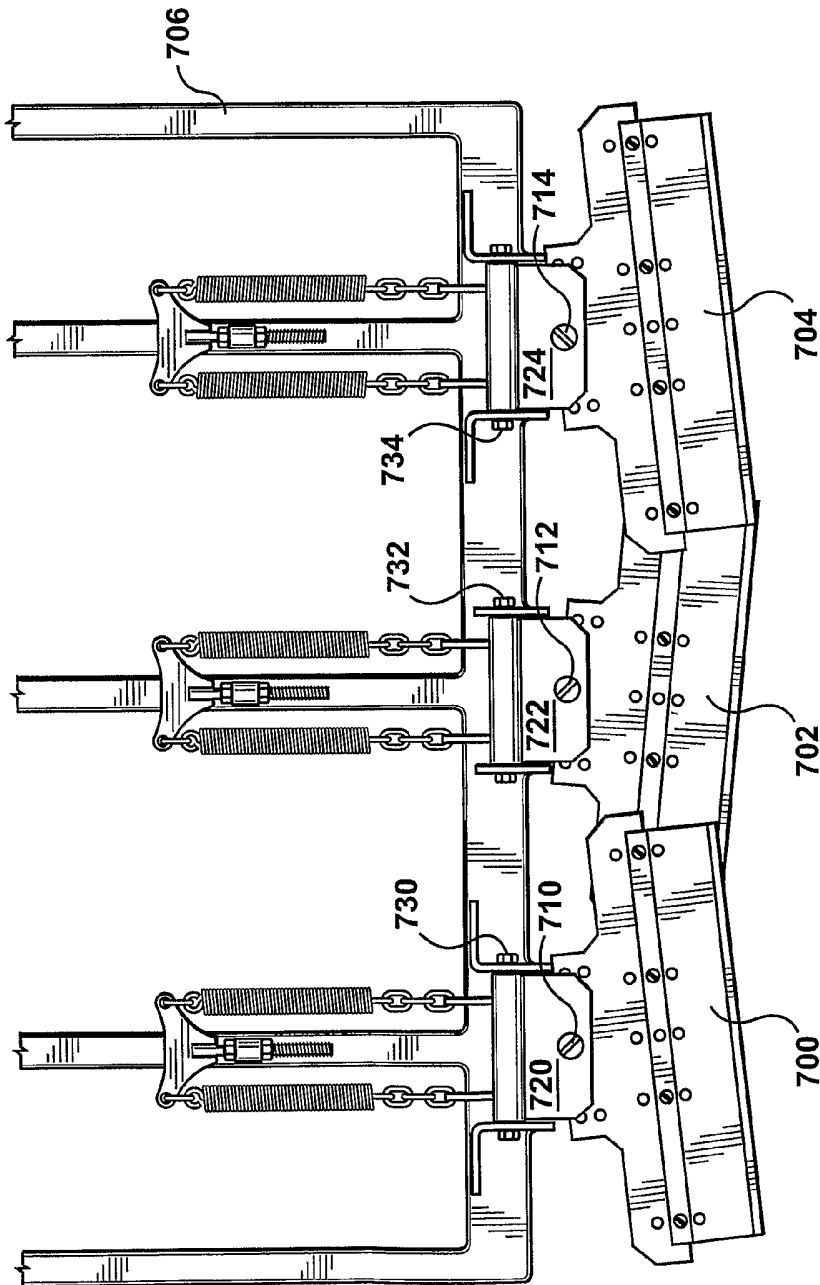

FIG. 53

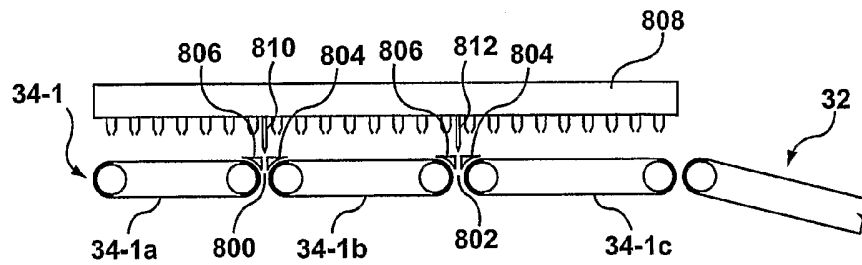

FIG. 54

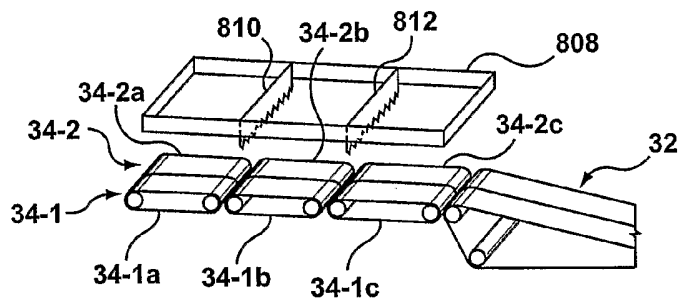

FIG. 55

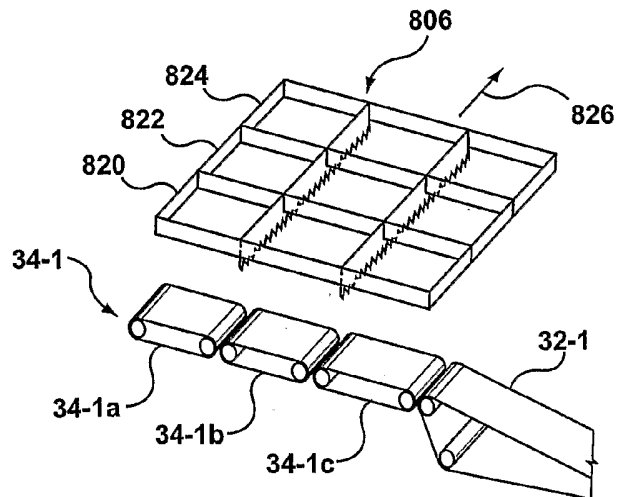

FIG. 56