

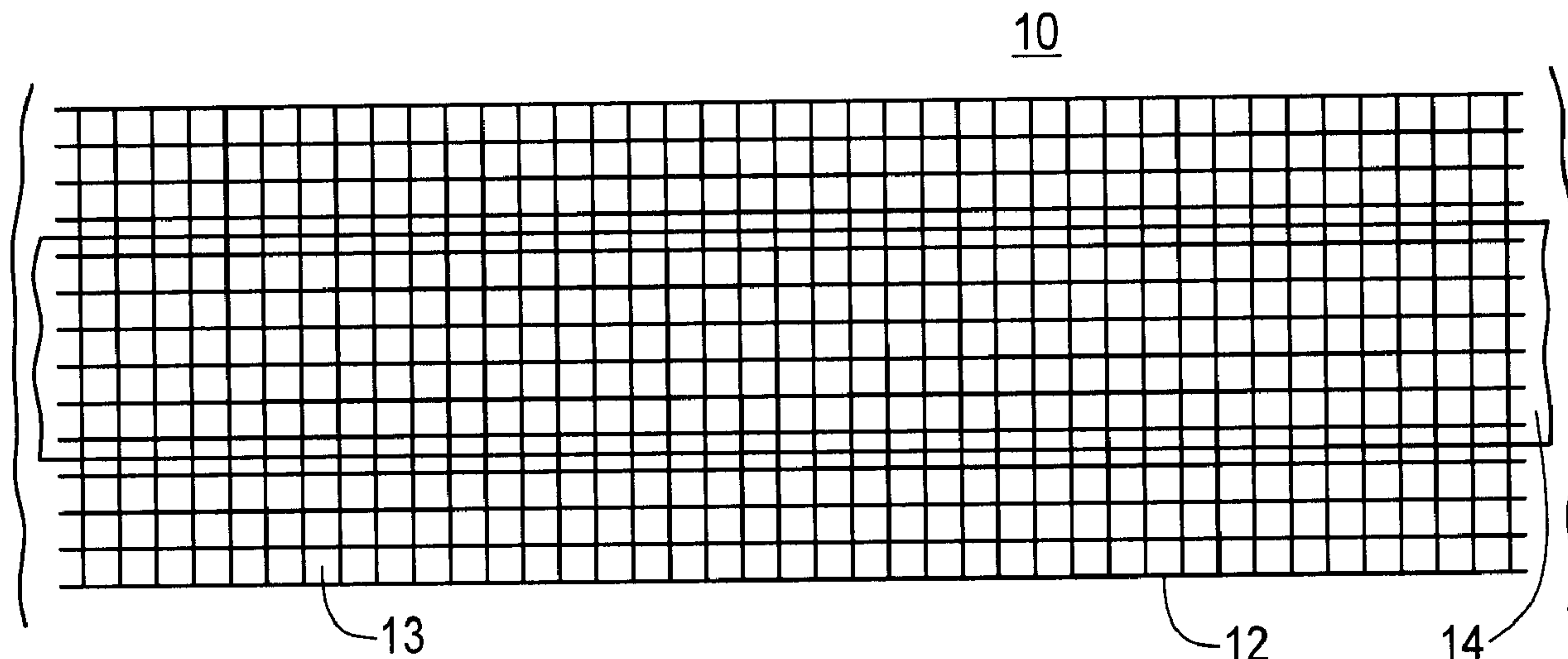

(22) Date de dépôt/Filing Date: 2011/03/02  
 (41) Mise à la disp. pub./Open to Public Insp.: 2011/09/04  
 (45) Date de délivrance/Issue Date: 2013/02/12  
 (30) Priorité/Priority: 2010/03/04 (US61/310,539)

(51) Cl.Int./Int.Cl. *C09J 7/02* (2006.01),  
*A47G 27/00* (2006.01), *A47G 27/04* (2006.01),  
*C09J 5/00* (2006.01), *E04F 15/00* (2006.01),  
*E04F 19/00* (2006.01)  
 (72) Inventeurs/Inventors:  
 DESPINS, MAURICE L., CA;  
 DESPINS, DAVID L., CA  
 (73) Propriétaire/Owner:  
 OMNIMART DISTRIBUTIONS INC., CA  
 (74) Agent: PARLEE MCLAWS LLP

(54) Titre : RUBAN DE JONCTION ET SA METHODE D'UTILISATION  
 (54) Title: SEAMING TAPE AND METHOD FOR USING SAME



(57) Abrégé/Abstract:

A seaming tape for joining pieces of floor-covering together, such as carpet or resilient floor covering material, and a method for using the same to join adjacent pieces of planar material is provided. The seaming tape can include an upper mesh tape portion and a lower blocking tape portion that is narrower in width than the mesh tape portion. The mesh tape portion can further include a pressure-sensitive adhesive to hold the blocking tape portion in position.

**ABSTRACT**

A seaming tape for joining pieces of floor-covering together, such as carpet or resilient floor covering material, and a method for using the same to join adjacent pieces of planar material is provided. The seaming tape can include an upper mesh tape portion and a lower blocking tape portion that is narrower in width than the mesh tape portion. The mesh tape portion can further include a pressure-sensitive adhesive to hold the blocking tape portion in position.

**TITLE:** SEAMING TAPE AND METHOD FOR USING SAME

**INVENTORS:** Maurice L. Despins and David L. Despins

**CROSS REFERENCE TO RELATED APPLICATIONS:**

[0001] This application claims priority of U.S. provisional patent application serial no. 61/310,539 filed March 4, 2010.

**TECHNICAL FIELD:**

[0002] The present disclosure is related to the field of seaming tapes, in particular, seaming tapes used in the seaming of planar materials, such as floor-coverings including carpet, resilient flooring material and the like.

**BACKGROUND:**

[0003] There is a need for a seaming tape for use in joining floor-coverings with liquid or thermoplastic seaming adhesives that prevents the intermingling of the seaming adhesives used to join pieces of floor-coverings with adhesive used to glue the floor-covering to a floor.

**SUMMARY:**

[0004] A seaming tape is provided that, in one embodiment, comprises an open mesh tape that overlays a strip of solid blocking tape that is narrower in width than the width of the mesh tape. In another embodiment, the mesh tape can be comprised of fiberglass mesh further comprising a plurality of openings approximately 1/8" square. In a further embodiment, the mesh tape can comprise a pressure-sensitive adhesive. In yet another embodiment, the blocking tape can be comprised of coated paper that can be disposed on the mesh tape and held in place by the pressure-sensitive adhesive disposed on the mesh tape.

[0005] In application and use, the seaming tape can be used to join adjacent pieces of floor-covering that can “float” on a floor, or that can be glued to the floor using floor adhesive. In the latter example where floor adhesive is used to glue the floor-covering to the floor, the seaming tape is placed on the floor with the blocking tape portion disposed between the floor and the mesh tape portion. The pieces of floor-covering to be joined can then be placed adjacent to each other on top of the seaming tape and then glued together using seaming adhesive dispensed by a seaming adhesive applicator tip, as well known to those skilled in the art. For the purposes of this specification, the term “seaming adhesive” can comprise liquid adhesives, thermoplastic adhesives (such as hot-melt glue) and any other form of adhesives used in the seaming of floor-covering materials as well known to those skilled in the art.

[0006] As seaming adhesive is dispensed between and underneath the edges of the pieces of floor-covering being joined together, the seaming adhesive can permeate the openings of the mesh tape. The blocking tape can act as a barrier to prevent the seaming adhesive from passing through the mesh tape. The blocking tape can also act to prevent the seaming adhesive and the floor adhesive from intermingling together, which can prevent the seaming adhesive from properly bonding the pieces of floor-covering together.

[0007] The applicant’s U.S. Patent No. 5,250,145 issued on October 5, 1993; U.S. Patent No. 6,997,227 issued on February 14, 2006; and U.S. Patent No. 7,381,289 issued on June 3, 2008 disclose examples of prior art applicator tips, and their use with seaming adhesives and tapes.

[0008] Broadly stated, in some embodiments, a seaming tape is provided, comprising: a mesh tape portion; and a blocking tape portion disposed beneath the mesh tape portion, the blocking tape portion being narrower in width than the width of the mesh tape portion.

[0009] Broadly stated, in some embodiments, a method is provided for seaming abutting side-by-side layers of planar material, the method comprising the steps of: fitting abutting edges of the abutting layers of planar material to one another to form a line of abutment; placing a length of seaming tape underneath the planar material along the line of abutment, the seaming tape further comprising a mesh tape portion and a blocking tape portion disposed beneath the mesh tape portion, the width of the blocking tape portion being narrower than the width of the mesh tape portion; dispensing seaming adhesive along one or both of the abutting edges and onto a top surface of the seaming tape abutting the planar material; and pressing the abutting edges of the abutting layers of planar material against each other and against the tape until the seaming adhesive has at least partially set so as to form a finished seam along the line of abutment.

[0010] Broadly stated, in some embodiments, a kit is provided for seaming abutting side-by-side layers of planar material, the kit comprising: a length of seaming tape, further comprising: a mesh tape portion, and a blocking tape portion disposed beneath the mesh tape portion, the width of the blocking tape portion being narrower than the width of the mesh tape portion.

[0011] Broadly stated, in some embodiments, a method is provided for seaming abutting side-by-side layers of planar material on an installation surface, the method

comprising the steps of: placing or installing one of the side-by-side layers of the planar material; marking a guide line along an abutting edge of the placed or installed planar material on the installation surface; placing a length of seaming tape underneath the placed or installed planar material along the guide line, the seaming tape further comprising a mesh tape portion and a blocking tape portion disposed beneath the mesh tape portion, the width of the blocking tape portion being narrower than the width of the mesh tape portion; placing or installing the other of the side-by-side layers of the planar material, and fitting abutting edges of the abutting layers of planar material to one another to form a line of abutment; dispensing seaming adhesive along one or both of the abutting edges, and dispensing adhesive onto a top surface of the seaming tape abutting the planar material; and pressing the abutting edges of the abutting layers of planar material against each other and against the tape until the adhesive has at least partially set so as to form a finished seam along the line of abutment.

**BRIEF DESCRIPTION OF THE DRAWINGS:**

[0012] Figure 1 is a top plan view depicting one embodiment of a seaming tape.

[0013] Figure 2 is a bottom plan view depicting the seaming tape of Figure 1.

[0014] Figure 3 is an exploded side elevation view depicting the seaming tape of Figure 1 joining two pieces of floor-covering together.

[0015] Figure 4 is a top perspective view depicting an alternate embodiment of the seaming tape of Figure 1.

[0016] Figure 5 is a top perspective view depicting a marking tool for use in the installation of the seaming tape of Figure 1.

[0017] Figure 6 is an end elevation view depicting the marking tool of Figure 5 being used in the installation of the seaming tape of Figure 1.

[0018] Figure 7 is a top perspective view depicting a second embodiment of a marking tool for use in the installation of the seaming tape of Figure 1.

[0019] Figure 8 is a top plan view depicting the marking tool of Figure 7 being used in the installation of the seaming tape of Figure 1.

#### **DETAILED DESCRIPTION OF EMBODIMENTS:**

[0020] Referring to Figures 1 and 2, one embodiment of seaming tape 10 is illustrated. In this embodiment, seaming tape 10 can comprise mesh tape portion 12 overlaid on blocking tape portion 14. In one embodiment, mesh tape portion 12 can be comprised of fiberglas mesh, such as the type used in the installation and repair of stucco although it is obvious to those skilled in the art that any suitable material for joining pieces of floor-covering together can be used for mesh tape portion 12, such as plastic mesh materials (including polypropylene and nylon mesh or webbing), textile materials (including fabrics and the like) or any other suitable materials known for reinforcing the seams between pieces of floor-covering materials.

[0021] In a representative embodiment, mesh tape portion 12 can have a width in the range of 2" to 3" although it is obvious to those skilled in the art that mesh tape portion 12 can be of any suitable width for joining adjacent pieces of floor-covering, whether that floor-covering is carpet or of resilient flooring material. In a further embodiment, mesh tape portion 12 can comprise a plurality of openings 13. In a representative embodiment, openings 13 are approximately 1/8" square although

any suitable sized opening for receiving seaming adhesive can be used. In a further embodiment, mesh tape portion 12 can comprise a pressure-sensitive adhesive.

[0022] In yet another embodiment, blocking tape portion 14 can be comprised of coated paper that can be disposed on mesh tape portion 12. It is obvious to those skilled in the art that other materials can be used for blocking tape portion 14, which can include plastic tape and/or fabric and other suitable textile materials that can provide a barrier between a floor and mesh tape portion 12. In a representative embodiment, blocking tape portion 14 can be approximately 1" to 1-1/2" wide although any suitable width can be used, as obvious to those skilled in the art, that is narrower in width than the width of mesh tape portion 12.

[0023] In one embodiment, blocking tape portion 14 can be held in place to mesh tape portion 12 by the pressure-sensitive adhesive disposed on mesh tape portion 12. It is obvious to those skilled in the art that seaming tape 10, when manufactured in volume, can be manufactured using mesh tape portion 12 that is not treated with a pressure-sensitive adhesive, and by applying a suitable adhesive between mesh tape portion 12 and blocking tape portion 14 and then sandwiching the tape portions together thereby bonding them together.

[0024] Referring to Figure 3, an exploded view of seaming tape 10 is shown in the seaming of two adjacent pieces of carpet 16 on floor 20. In this representative embodiment, seaming tape 10 is configured with mesh tape portion 12 facing up towards carpet 16, and blocking tape portion 14 facing down towards floor 20. Floor adhesive 22, as well known to those skilled in the art, is placed on floor 20. Seaming tape 10 is placed on top of floor adhesive 22 along the line where the

adjacent pieces of carpet 16 will join together along seam 17. Seaming adhesive 18 can be applied between and beneath the edges of carpet 16 being joined together using a seaming adhesive applicator tip (not shown) as well known by those skilled in the art. Openings 13 in mesh tape portion 12 receive seaming adhesive 18 dispensed between the pieces of carpet 16 and aid in distributing the hot glue to carpet 16. Blocking portion 14, disposed beneath mesh tape portion 12 and above floor adhesive 22 acts as a barrier with at least two functions. A first function of blocking tape portion 14 is to prevent hot glue 18 from passing through openings 13 of mesh tape portion 12, thereby preventing full adhesion of seaming adhesive 18 to pieces of carpet 16. A second function of blocking tape portion 14 is to prevent the intermingling of floor adhesive 22 with seaming adhesive 18 that can prevent seaming adhesive 18 from fully bonding pieces of carpet 16 to each other.

[0025] Referring to Figure 4, an alternate embodiment of seaming tape 10 is shown. In this embodiment, seaming tape 10 can further comprise center line 24 disposed on a top surface thereof. In some embodiments, center line 24 can be disposed along the length of seaming tape 10 substantially in the middle or centered between edges 15 of seaming tape 10. Center line 24 can provide means to visually guide an installer to place seaming tape 10 substantially centered underneath the gap between two pieces of floor-covering to be joined or seamed together. In some embodiments, center line 24 can be a solid line. In other embodiments, center line 24 can be a dashed or dotted line, or combinations thereof. In further embodiments, center line 24 can be a line of printed text, such as the manufacturer's name, the lot number or production run number, the date of manufacture, or any other text, or any

other visual marking disposed substantially down the center of seaming tape 10 between edges 15 wherein center line 10 that can function as a visual guide to indicate the center of seaming tape 10.

[0026] In some embodiments, center line 24 can comprise a colored thread disposed in mesh tape portion 12. In other embodiments, center line 24 can be printed on blocking tape portion 14. In further embodiments, center line 24 can comprise painting or marking a line of paint or ink on mesh tape portion 12 or on blocking tape portion 14. In further embodiments, center line 24 can comprise a colored tape disposed on mesh tape portion 12 or between mesh tape portion 12 and blocking tape portion 14.

[0027] Referring to Figure 5, marking tool 26 is shown, which can be used in the installation of seaming tape 10 when seaming pieces of floor-covering together. In some embodiments, marking tool 26 can comprise flat substrate 27 and stop 28 disposed on top thereof, thereby forming floor-covering side 30 and marking side 32 further comprising marking edge 34.

[0028] Referring to Figure 6, marking tool 26 is shown being used with piece of carpet 16. Floor-covering side 30 of marking tool 26 can be placed underneath carpet 16 wherein carpet 16 abuts stop 28. In some embodiments, the dimension of marking side 32 can be selected wherein the distance "X", as shown in Figure 6, is approximately the same as the lateral distance between center line 24 and edge 15 of seaming tape 10, as shown in Figure 4.

[0029] When installing seaming tape 10 between abutting side-by-side layers of planar material, such as floor-coverings, carpet, etc., an installer can first place or

install one of the side-by-side layers of the planar material. While the planar material is typically installed on a horizontal surface such as a floor or stair treads or other horizontal surfaces as obvious to those skilled in the art, the planar material can also be installed on non-horizontal surfaces as obvious to those skilled in the art. Upon installing the first piece of planar material to be seamed, such as carpet 16 shown in Figure 6, the installer can run marking tool 26 along an abutting edge of carpet 16 while using marking pen or pencil 36 to draw a guide line along marking edge 34 on the floor adjacent to the abutting edge of carpet 16. Once a line has been drawn on an installation surface (the floor in the illustrated example shown in Figure 6) along the edge of carpet 16, the drawn line can provide a visual guide to the installer as to where edge 15 of seaming tape 10 should lay underneath carpet 16 when seaming carpet 16 to another piece of carpet. In so doing, center line 24 should lay along the edge of carpet 16 where the seam is to be made to provide a visual guide to the installer that seaming tape 10 is properly positioned underneath carpet 16.

[0030] Referring to Figure 7, an alternate embodiment of a marking tool is shown for drawing a guide line. In some embodiments, marking tool 38 can comprise cylindrical portion 40 disposed on top of flange portion 42, with marking pen opening 44 extending therethrough. In some embodiments, the diameter of cylindrical portion 40 can be selected wherein its radius can be approximately distance "X" as shown in Figure 6.

[0031] Referring to Figure 8, marking tool 38 is shown in use to mark guide line 46. Flange portion 42 can be placed under carpet 48 until cylindrical portion 40 abuts edge 50 of carpet 48. Marking pen 36 can be inserted through opening 44 to mark

guide line 46 on the floor. An installer can then move marking tool 38 down along edge 50 whereby cylindrical portion 42 rolls along edge 50 resulting in marking pen 36 marking guide line 46 on the floor substantially parallel to edge 50.

[0032] In some embodiments, a kit is provided for seaming abutting side-by-side layers of planar material. The kit can comprise a length of seaming tape 10. In other embodiments, the kit can comprise a set of instructions explaining how seaming tape 10 can be used to seam abutting side-by-side layers of planar material. In further embodiments, the kit can comprise marking tool 26. In other embodiments, the kit can comprise marking tool 38. In yet further embodiments, the kit can further comprise a marking pen or pencil for use with marking tool 26 or marking tool 38.

[0033] Although a few embodiments have been shown and described, it will be appreciated by those skilled in the art that various changes and modifications might be made without departing from the scope of the invention. The terms and expressions used in the preceding specification have been used herein as terms of description and not of limitation, and there is no intention in the use of such terms and expressions of excluding equivalents of the features shown and described or portions thereof, it being recognized that the scope of the invention is defined and limited only by the claims that follow.

**WE CLAIM:**

1. A seaming tape, comprising:
  - a) a mesh tape portion; and
  - b) a blocking tape portion disposed beneath the mesh tape portion, the width of the blocking tape portion being narrower than the width of the mesh tape portion.
2. The seaming tape as set forth in claim 1, wherein the mesh tape portion is comprised of fiberglass mesh tape.
3. The seaming tape as set forth in claim 2, wherein the fiberglass mesh tape further comprises a pressure-sensitive adhesive disposed thereon.
4. The seaming tape as set forth in claim 3, wherein the pressure-sensitive adhesive holds the blocking tape portion to the mesh tape portion.
5. The seaming tape as set forth in any one of claims 1 to 4, wherein the blocking tape portion is comprised of coated paper.
6. The seaming tape as set forth in any one of claims 1 to 5, further comprising a center line disposed thereon.
7. A method of seaming abutting side-by-side layers of planar material, the method comprising the steps of:
  - a) fitting abutting edges of the abutting layers of planar material to one another to form a line of abutment;
  - b) placing a length of seaming tape underneath the planar material along the line of abutment, the seaming tape further comprising a mesh tape portion and a blocking tape portion disposed beneath the mesh tape portion, the

width of the blocking tape portion being narrower than the width of the mesh tape portion;

- c) dispensing seaming adhesive along one or both of the abutting edges and dispensing adhesive onto a top surface of the seaming tape abutting the planar material; and
  - d) pressing the abutting edges of the abutting layers of planar material against each other and against the tape until the adhesive has at least partially set so as to form a finished seam along the line of abutment.
8. The method as set forth in claim 7, wherein the mesh tape portion is comprised of fiberglass mesh tape.
9. The method as set forth in claim 8, wherein the fiberglass mesh tape further comprises a pressure-sensitive adhesive disposed thereon.
10. The method as set forth in claim 9, wherein the pressure-sensitive adhesive holds the blocking tape portion to the mesh tape portion.
11. The method as set forth in any one of claims 7 to 10, wherein the blocking tape portion is comprised of coated paper.
12. The method as set forth in any one of claims 7 to 11, wherein the seaming tape further comprises a center line disposed thereon.
13. A kit for seaming abutting side-by-side layers of planar material, the kit comprising:
- a) a length of seaming tape, further comprising:
    - i) a mesh tape portion, and

- ii) a blocking tape portion disposed beneath the mesh tape portion, the width of the blocking tape portion being narrower than the width of the mesh tape portion.
14. The kit as set forth in claim 13, wherein the mesh tape portion is comprised of fiberglass mesh tape.
  15. The kit as set forth in claim 14, wherein the fiberglass mesh tape further comprises a pressure-sensitive adhesive disposed thereon.
  16. The kit as set forth in claim 15, wherein the pressure-sensitive adhesive holds the blocking tape portion to the mesh tape portion.
  17. The kit as set forth in any one of claims 13 to 16, wherein the blocking tape portion is comprised of coated paper.
  18. The kit as set forth in any one of claims 13 to 17, further comprising a center line disposed thereon.
  19. The kit as set forth in any one of claims 13 to 18, further comprising a marking tool.
  20. The kit as set forth in claim 19, wherein the marking tool comprises:
    - a) a substrate; and
    - b) a stop disposed thereon, thereby forming a floor-covering side and a marking side further comprising a marking edge.
  21. The kit as set forth in claim 19, wherein the marking tool comprises:
    - a) a cylindrical portion;
    - b) a flange portion comprising the cylindrical portion disposed thereon; and

- c) an opening extending through the cylindrical portion and the flange portion.
22. A method of seaming abutting side-by-side layers of planar material on an installation surface, the method comprising the steps of:
- a) placing or installing one of the side-by-side layers of the planar material;
  - b) marking a guide line along an abutting edge of the placed or installed planar material on the installation surface;
  - c) placing a length of seaming tape underneath the placed or installed planar material along the guide line, the seaming tape further comprising a mesh tape portion and a blocking tape portion disposed beneath the mesh tape portion, the width of the blocking tape portion being narrower than the width of the mesh tape portion;
  - d) placing or installing the other of the side-by-side layers of the planar material, and fitting abutting edges of the abutting layers of planar material to one another to form a line of abutment;
  - e) dispensing seaming adhesive along one or both of the abutting edges, and dispensing adhesive onto a top surface of the seaming tape abutting the planar material; and
  - f) pressing the abutting edges of the abutting layers of planar material against each other and against the tape until the adhesive has at least partially set so as to form a finished seam along the line of abutment.
23. The method as set forth in claim 22, wherein the guide line is marked using a marking tool.

24. The method as set forth in claim 22 or claim 23, wherein the mesh tape portion is comprised of fiberglas mesh tape.
25. The method as set forth in claim 24, wherein the fiberglas mesh tape further comprises a pressure-sensitive adhesive disposed thereon.
26. The method as set forth in claim 25, wherein the pressure-sensitive adhesive holds the blocking tape portion to the mesh tape portion.
27. The method as set forth in any one of claims 22 to 26, wherein the blocking tape portion is comprised of coated paper.
28. The method as set forth in any one of claims 22 to 27, wherein the seaming tape further comprises a center line disposed thereon.

1/5

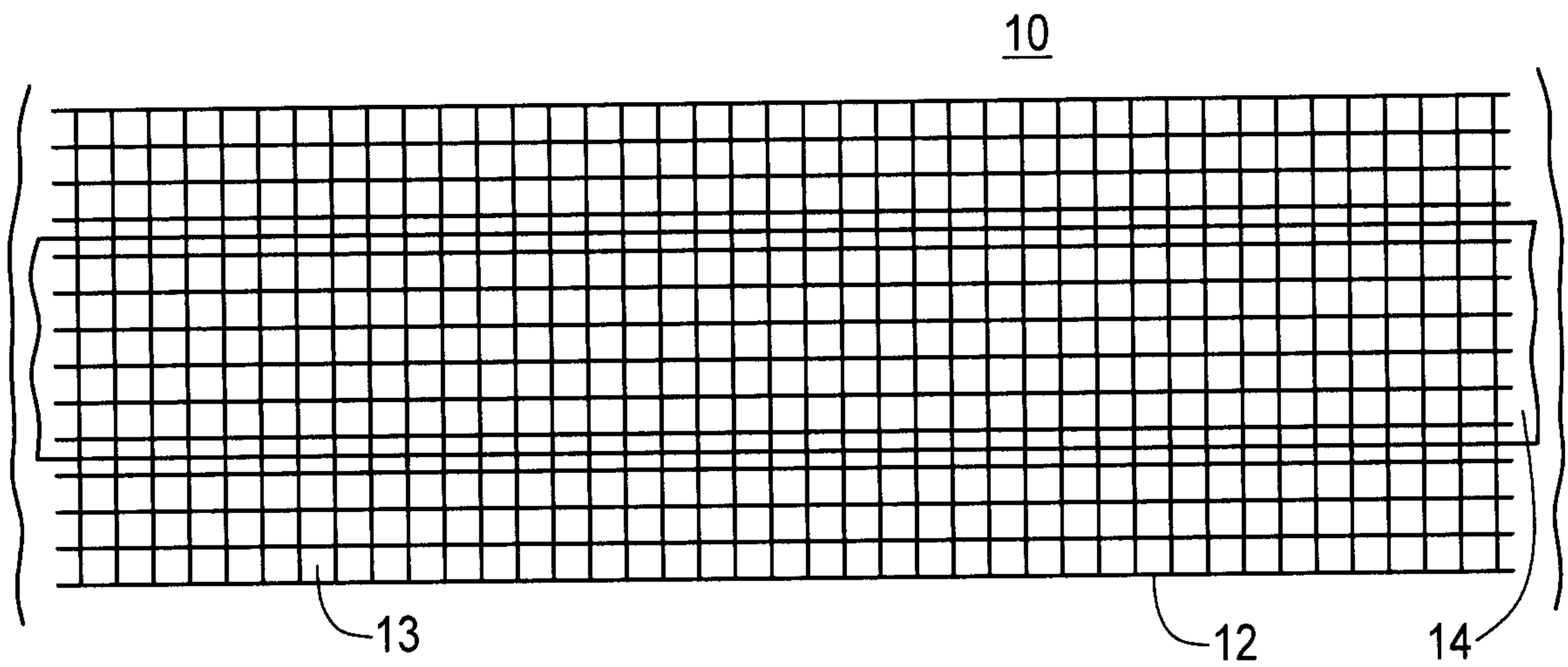

FIG. 1

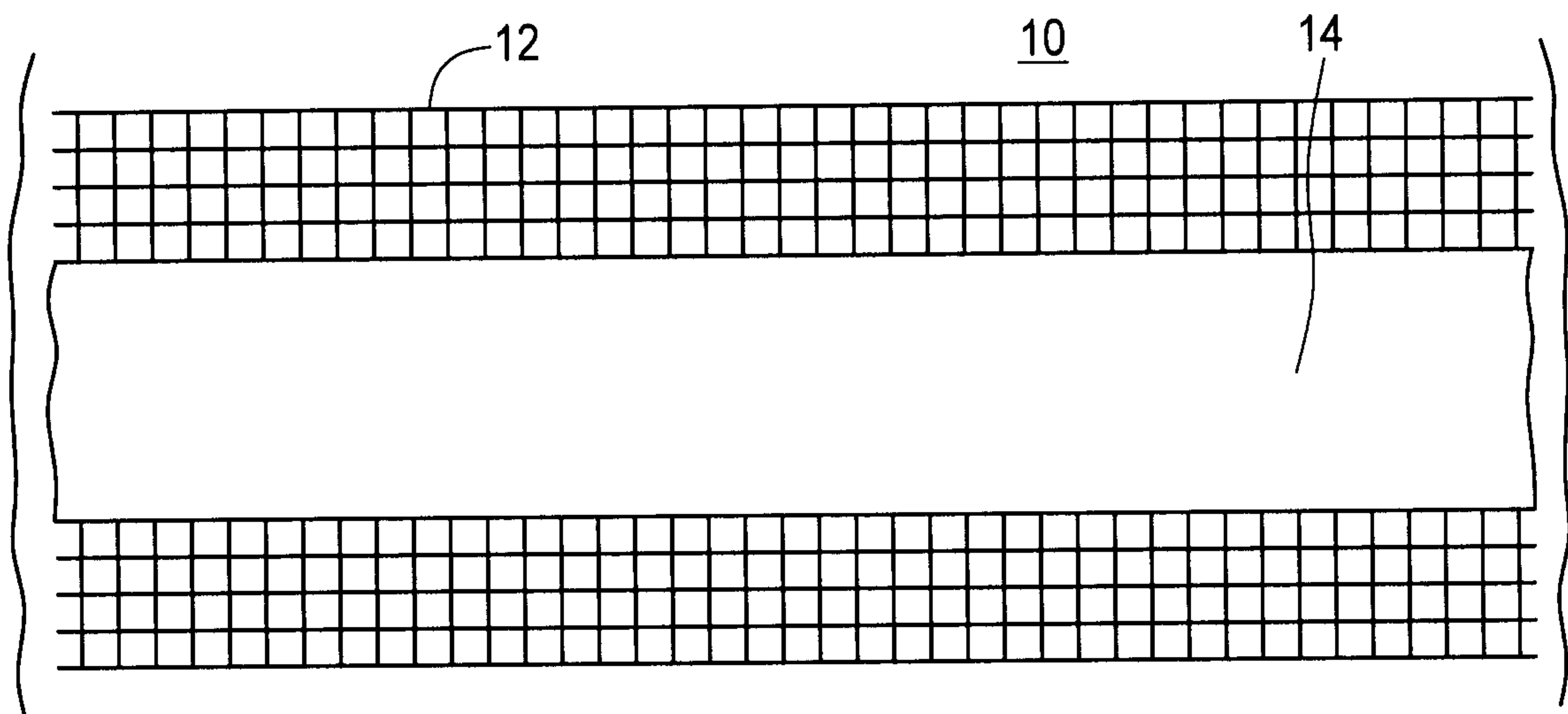

FIG. 2

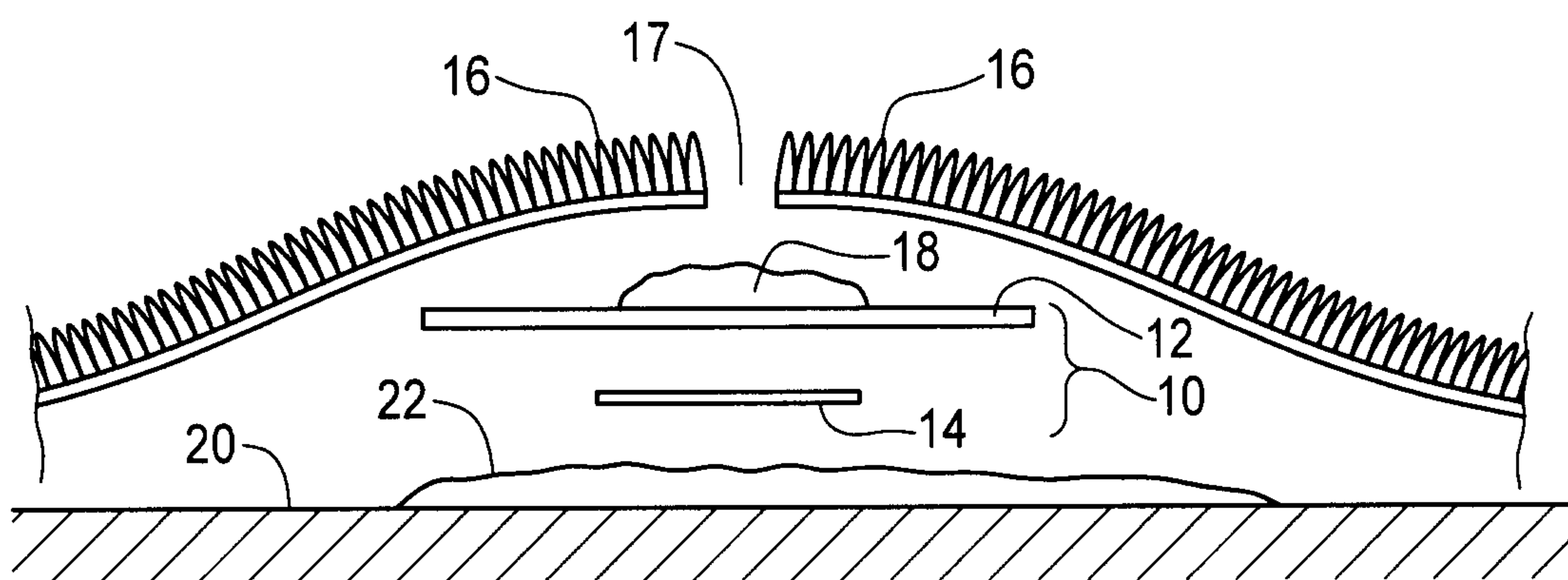

FIG. 3

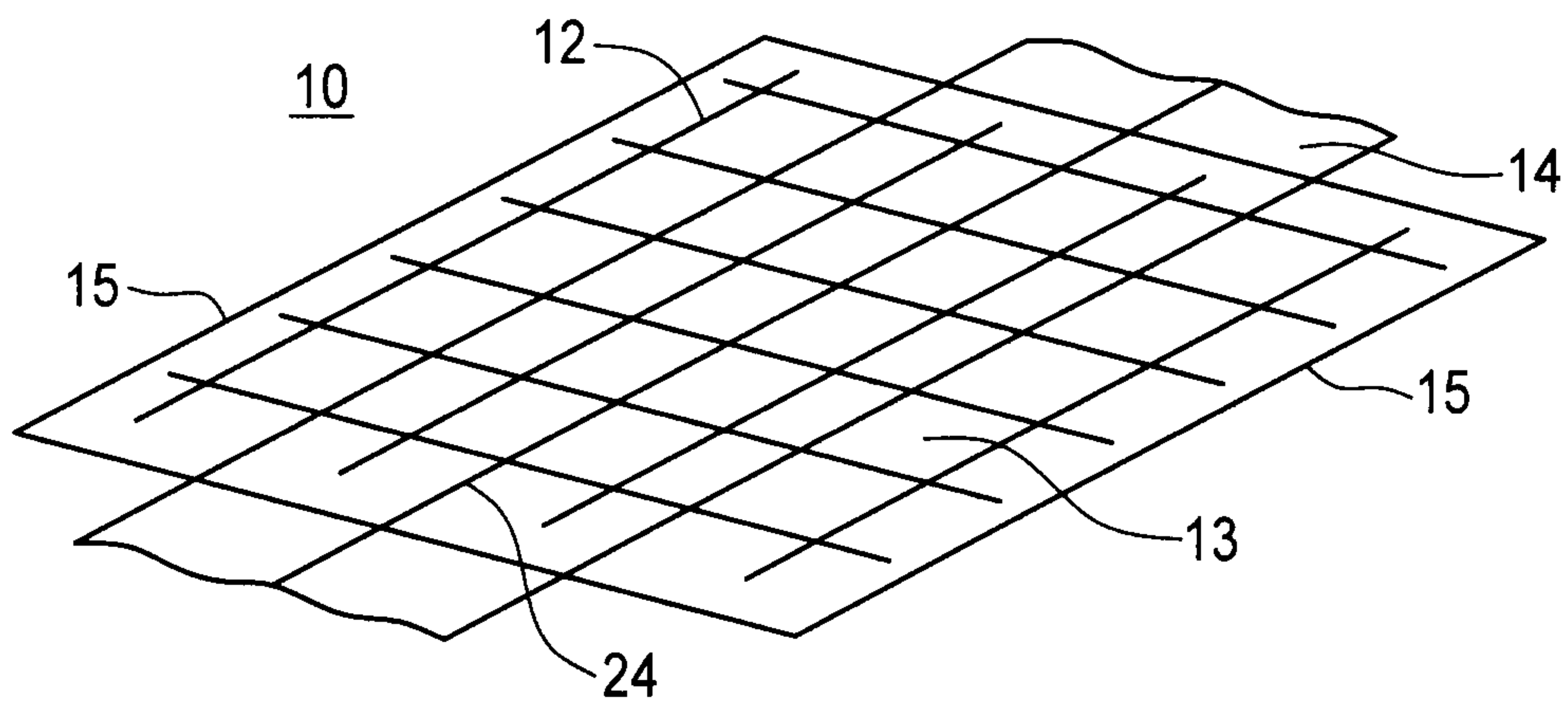

FIG. 4

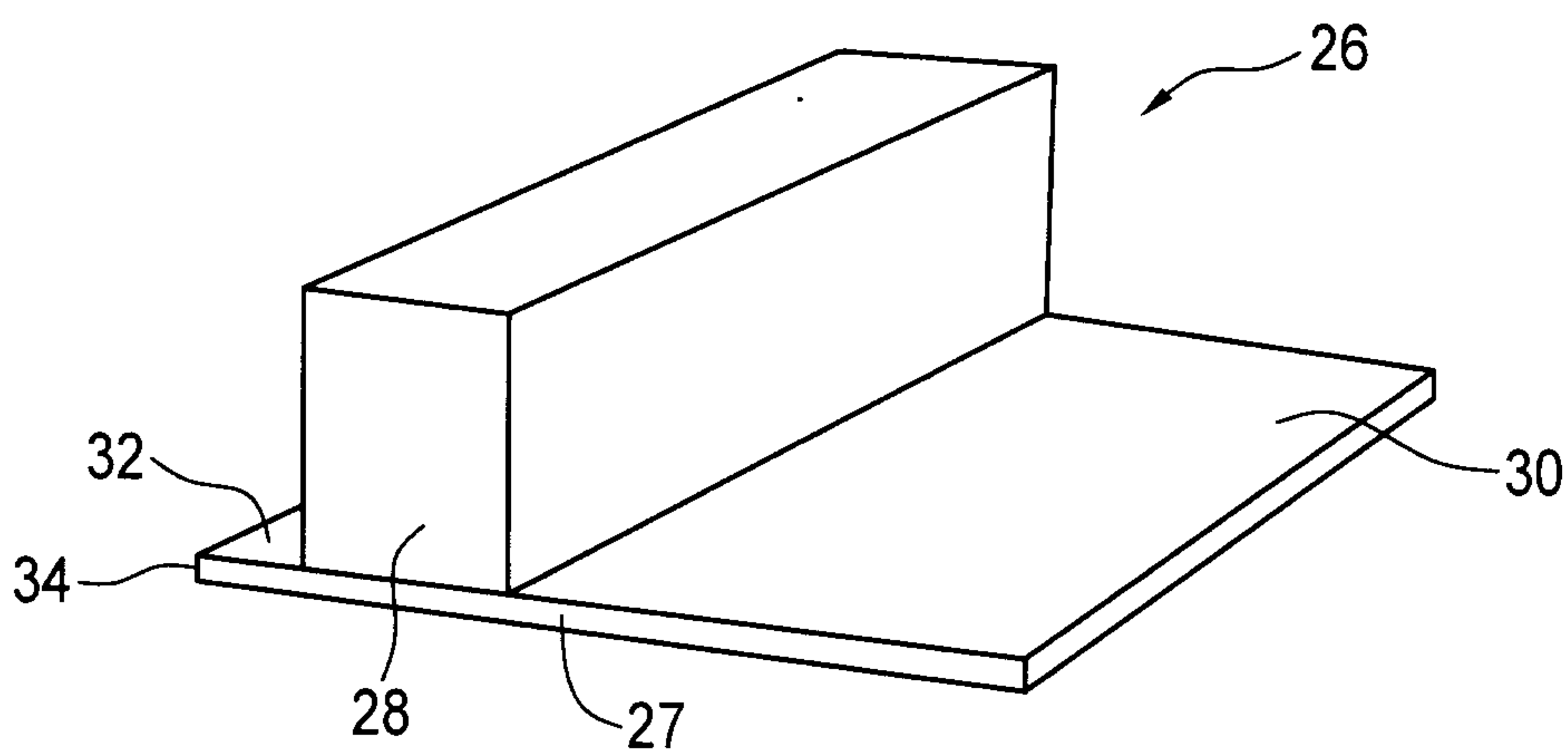

FIG. 5

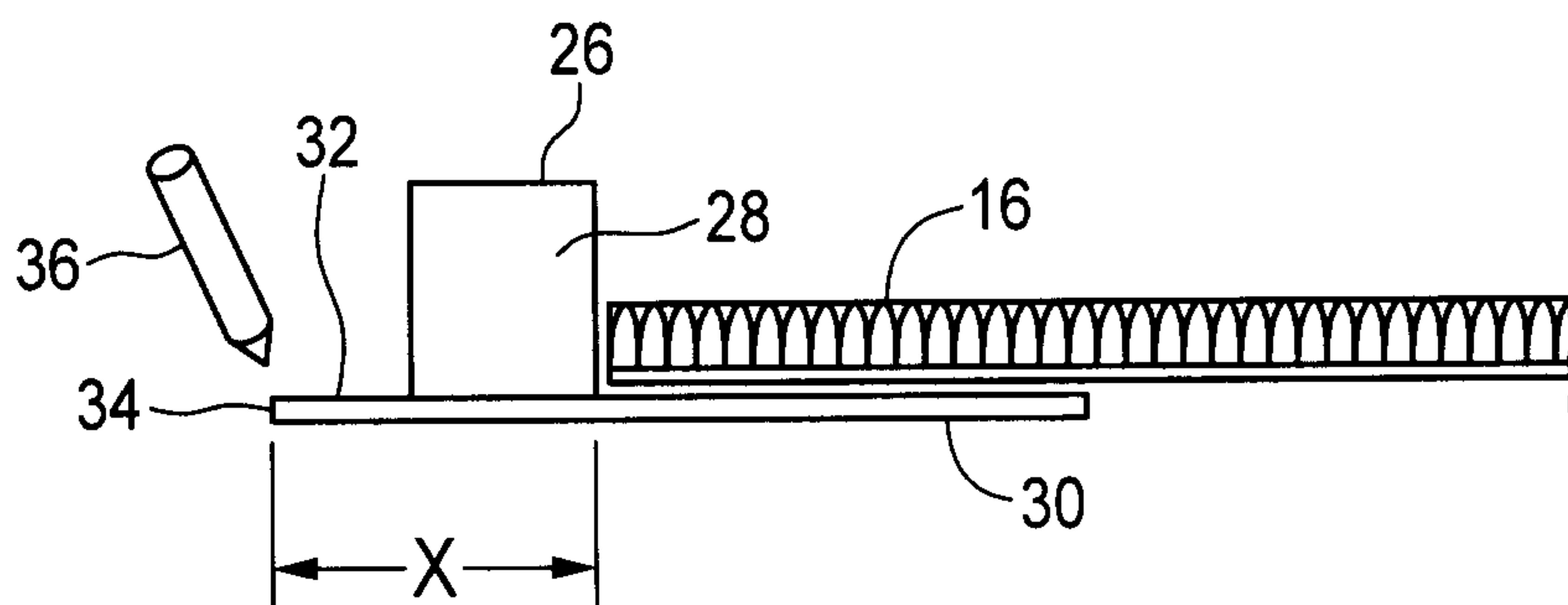

FIG. 6

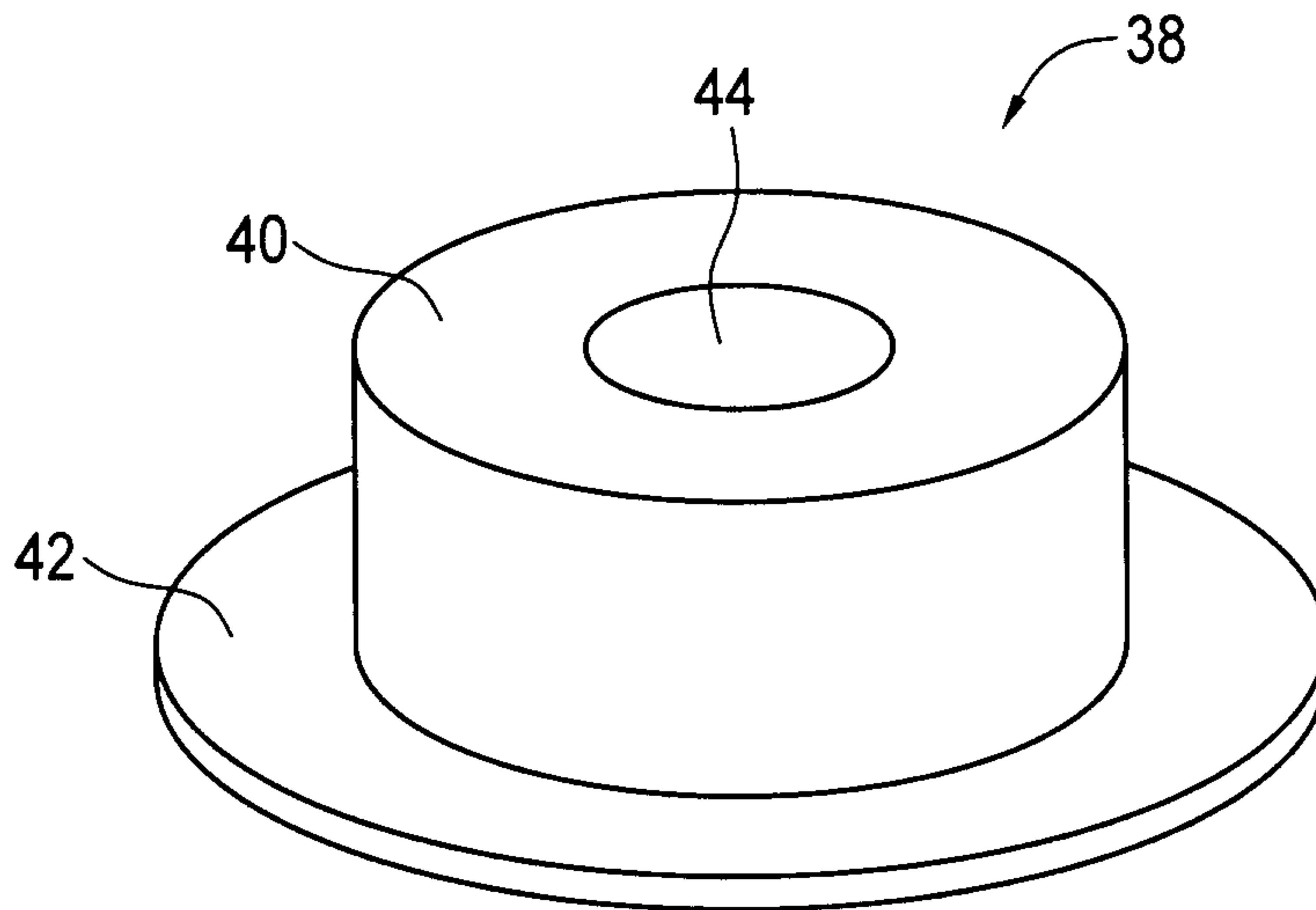

FIG. 7

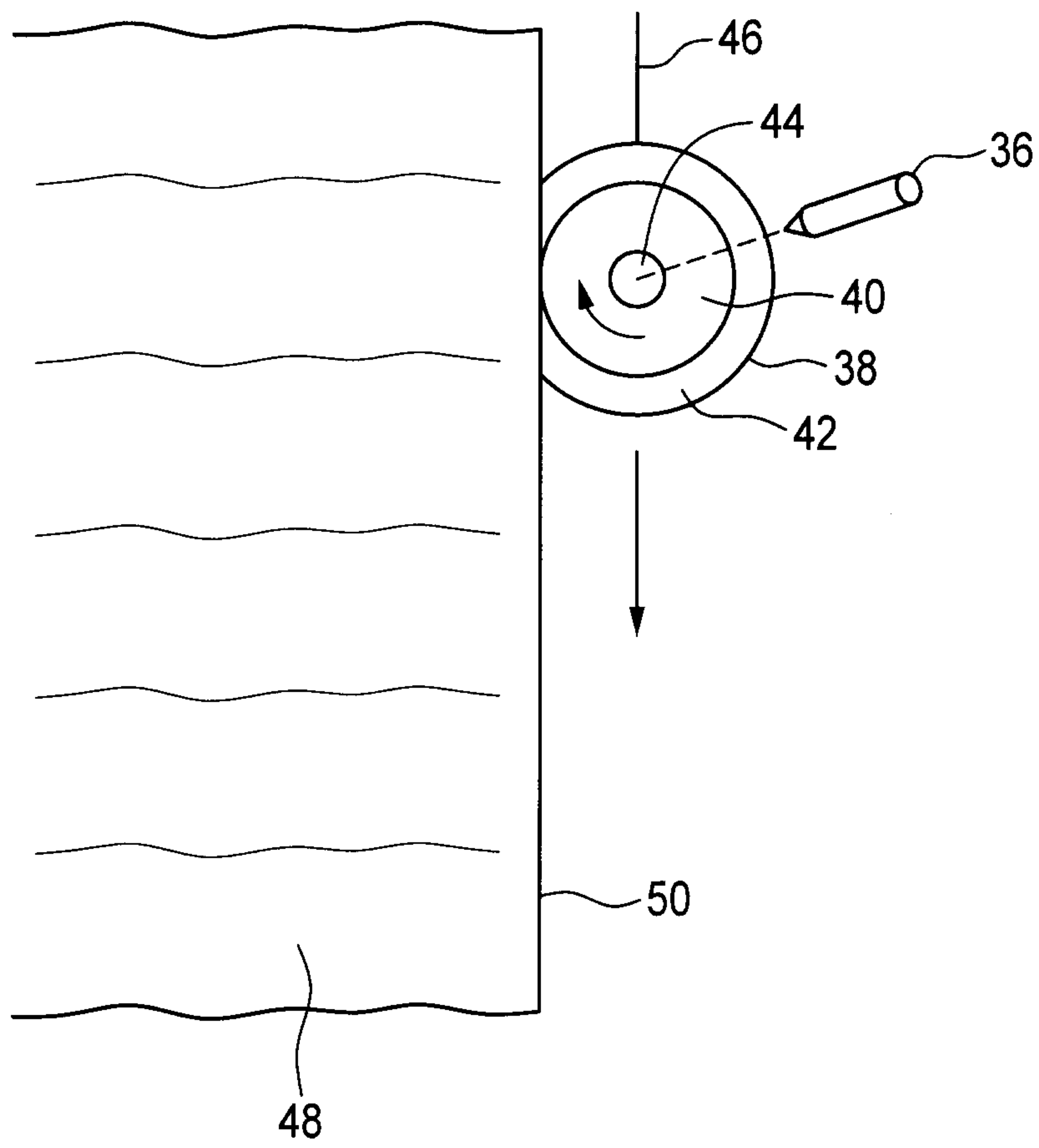
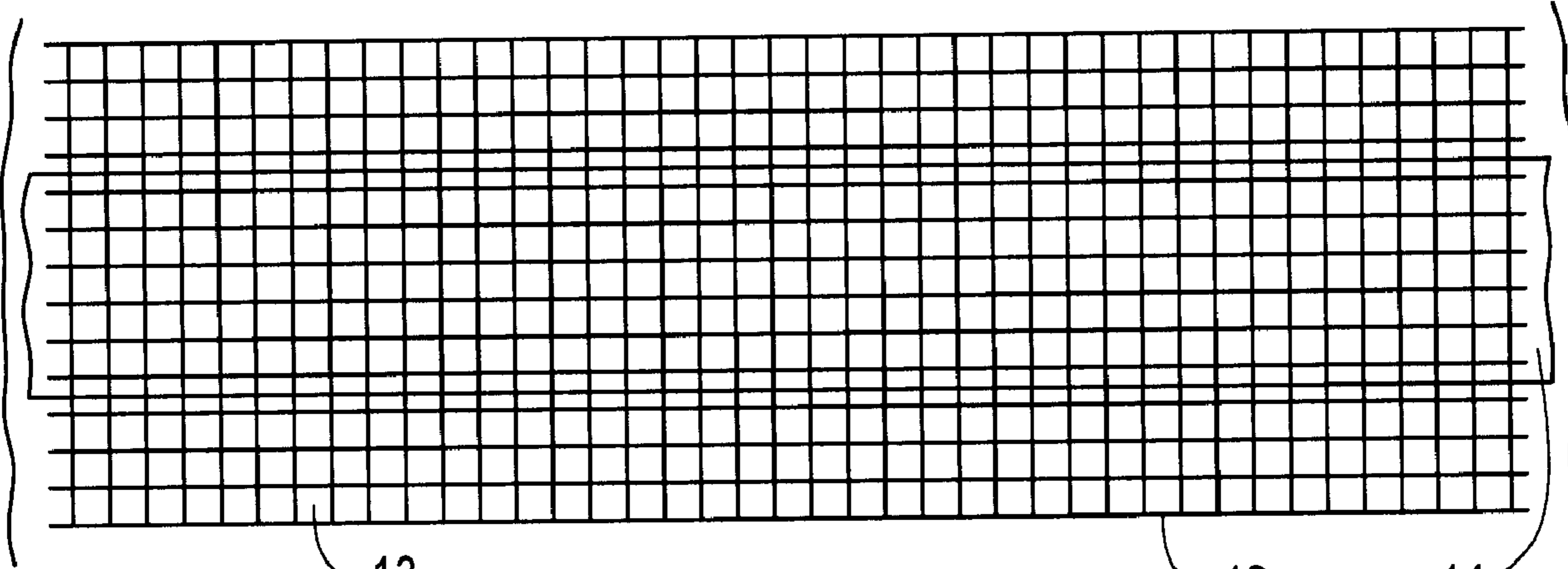

FIG. 8

10



13

12

14