



12

EUROPEAN PATENT SPECIFICATION

45 Date of publication of patent specification :
28.04.93 Bulletin 93/17

51 Int. Cl.⁵ : **F24F 9/00, F24F 13/075**

21 Application number : **89202490.2**

22 Date of filing : **02.10.89**

54 **Air curtain device.**

30 Priority : **04.10.88 NL 8802430**

43 Date of publication of application :
11.04.90 Bulletin 90/15

45 Publication of the grant of the patent :
28.04.93 Bulletin 93/17

84 Designated Contracting States :
AT BE CH DE ES FR GB GR IT LI LU NL SE

56 References cited :
DE-U- 8 716 517
US-A- 2 057 494
US-A- 3 229 609
US-A- 3 291 027
US-A- 3 327 935
US-A- 3 332 334
US-A- 3 362 469

56 References cited :
PATENT ABSTRACTS OF JAPAN, vol. 1, no. 137, 11th November 1977, page 4774 M 77; & JP-A-52 78 152 (FUJI DENKI SEIZO K.K.) 01-07-1977
PATENT ABSTRACTS OF JAPAN, vol. 1, no. 22, 25th March 1977, page 1631 M 76; & JP-A-51 134 462 (SANYO DENKI K.K.) 20-11-1976

73 Proprietor : **F.H. BIDDLE B.V.**
Markowei 4
NL-9288 HA Kootsertille (NL)

72 Inventor : **Ligtenberg, Petrus Josephus**
Joannes Hubertus, Ir.
Slinge 23
NL-9204 KK Drachten (NL)

74 Representative : **'t Jong, Bastiaan Jacobus et al**
OCTROOIBUREAU ARNOLD & SIEDSMA
Sweelinckplein 1
NL-2517 GK 's-Gravenhage (NL)

EP 0 362 958 B1

Note : Within nine months from the publication of the mention of the grant of the European patent, any person may give notice to the European Patent Office of opposition to the European patent granted. Notice of opposition shall be filed in a written reasoned statement. It shall not be deemed to have been filed until the opposition fee has been paid (Art. 99(1) European patent convention).

Description

The invention relates to an air curtain device as described in the preamble of claim 1.

Such a device is known from US-A-3 229 609 and is generally used in the passage openings of buildings, for instance shops and department stores. The air curtain generated by the device at the location of the passage opening is intended to maintain a separation between the climate in the building and the climate outside it. Due to the air curtain it is possible to have a visually completely free passage opening, without the energy loss resulting from the escape of for instance heated or cooled air from the building assuming inadmissible proportions. The air flowing out of the air outflow opening of the device is itself usually heated or cooled. Since at least some air escapes from a building, for instance through gaps and ventilation openings, air from outside the building will flow inside at the location of the passage opening into the building. This air is hereby mixed with the air of the air curtain, so that this is brought to the desired temperature. In this way a considerable portion of the energy used to bring the air in the air curtain to the desired temperature is to the benefit of the interior climate of the building.

Through direct contact with the outside air a certain loss of energy is of course unavoidable.

The invention has for its object to provide an air curtain device of the kind described above, which operates with a minimum of energy loss.

This object is achieved according to the invention with the characterizing features of claim 1. It has been found that with these features a flat stream of air is generated which has a "smooth" interface with the outside air, whereby relatively little air from the air curtain mixes with the outside air and escapes outside. It has moreover been found that with the obtained low degree of turbulence of the outflowing air, the flat stream of air penetrates deeply. A small amount of blownout air can as a result be sufficient to still achieve the desired separating effect.

Considering the flow conditions it is naturally not possible to achieve a completely laminar flow. It has however been found that through the invention the degree of turbulence of the air blown out of an air curtain device can be reduced in a manner such that on the basis of the above described mechanisms a considerable energy saving can be achieved.

A very favourable embodiment is characterized in claim 2. It has been found that this embodiment has a very favourable effect on the air eddyings, while moreover the flow resistance is limited.

A further advantage of this embodiment occurs in combination with the characterizing steps of claim 3. Since in the lengthwise direction the fans have outlet openings lying at a mutual distance, the air supply at the level of the fans is not uniform. It is now been

found with the strip-like guide elements that the unevenly supplied air leaves the guide elements as a very considerably more uniform, flat stream of air. It is thus hereby possible to choose fans which in view of the required supply and the occurring pressure differences have a maximum output. The fact that thereby the air does not leave the fans uniformly as seen in the lengthwise direction of the device is of less importance in this embodiment. Because the optimal fans can be chosen an energy saving can in this manner likewise be achieved.

When further the step of claim 4 is applied, the air supply per unit of length of the air outflow opening becomes still more uniform. After passing the strip-like guide elements the flat stream of air is then also virtually completely continuous in lengthwise direction. The level of turbulence is hereby further reduced in a favourable manner.

A further development of the device according to the invention is characterized in claim 5. As required by the circumstances of use of the device the outflow direction of the flat stream of air can hereby be slightly altered. This can for instance be directed slightly sloping to the outside.

From US-A-3 362 469 an air curtain device is known having an elongate slot-like opening. The device has only one air outflow channel having a portion with a constant section in the outflow direction. The lengthwise dimension of this portion with constant section is substantially less than 5 times the transverse dimension thereof.

The invention will be further elucidated in the following description with reference to the embodiments shown in the figures.

Fig. 1 shows a perspective view diagonally from below of an air curtain device according to the invention in a preferred embodiment.

Fig. 2 shows a partially sectional perspective view according to arrow II in fig. 1.

Fig. 3 shows a partially broken away perspective view, according to arrow III in fig. 2, of an alternative embodiment.

Fig. 4 shows schematically a number of possible embodiments of turbulence reducing elements for use with an air curtain device according to the invention.

The air curtain device 1 shown in fig. 1 is mounted in a manner to be further described above a passage opening in a building 2. This passage opening can be the entrance or a connecting opening between two areas of the building.

The device 1 comprises a housing 3 which is provided with an elongate air outflow opening 6. Air supply means, which in the embodiment shown and described here are formed by fans accommodated in the housing 3 of the device 1, are connected to the air outflow opening 6. The air is drawn in through inlet grids 5, which are formed in covers 4 closing off the housing 3. Arranged in the outflow opening 6 are ele-

ments 7 which reduce the turbulence of the blown out air. The flat stream of air 8 leaving the opening 6 penetrates to the bottom of the passage opening and thus forms in a per se known manner a separation between the two climates on either side of the air curtain 8.

Fig. 2 shows in more detail the construction of the air curtain device 1.

The housing 3 of the device 1 is suspended from a horizontal ceiling surface by means of mounting strips 10, which are themselves screwed fixedly into the ceiling of the building 2 and are bent over at their ends into hooks 11 in the manner shown in the drawing. In the housing 3 of the device 1 two channels 12 are formed, on one upper edge of which an inwardly protruding edge 13 of plate material is formed. After fixing of the mounting strips 10 the device can simply be suspended on the hooks 11 thereof by manipulating the device 1 such that the hooks 11 are placed into the channels 12 and come to fall behind the edges 13. After adjusting the position of the device 1 by sliding in transverse direction of the mounting strips, the final position can be fixed using locking screws 14. This fitting with mounting strips 10 has the advantage that the mounting position of the device is to a large degree independent of the bearing construction in the ceiling. The strips can be simply attached in the suitable positions in their lengthwise direction to the bearing parts.

Air filter elements 15 are arranged in the housing 3 of the device 1 behind the inlet grids 5. These filter elements 15 can be changed and are accessible through downward swivelling of the covers 4.

The air supply means are, as previously noted, formed by a number of fans 16. Arranged in the housing 3 between the air filters 15 and the fans 16 is a heat exchanger 23. The indrawn air is heated or cooled in this heat exchanger in accordance with the desired use.

Each fan 16 comprises an electric motor 17, which drives a rotor 18. The fan housing 19 formed as a so-called snail shell extends around the rotor. The fan 16 is mounted with the housing 19 on a mounting plate 27 of the housing 3. Openings 20 corresponding with the fans are arranged in this plate.

As shown, the fans 16 applied here are radial fans with suction openings on either side of the fan housing 19. Fans of this type have a favourable output for the conditions intended here.

The drawback of a number of separate, adjacently disposed fans is however that the outlet openings 20 likewise lie in a number of discrete locations, so that the air to be blown out is not released uniformly over the lengthwise direction of the outflow opening 6. An important additional advantage of the invention is that it also obviates these drawbacks.

Connecting onto the outlet openings 20 of the fans are dividing plates 21 which extend up to the tur-

bulence reducing elements at the location of the outflow opening 6. In the embodiment shown in fig. 2 these elements are formed by guide elements 22 which are formed by strip-like elements extending in the lengthwise direction of the air outflow opening 6 and parallel to each other. The distance between the strip-like guide elements is smaller than or equal to one fifth of the height of these strip-like elements 22. The guide elements provide in the first instance the effect intended by the invention of reducing the degree of turbulence in the outflowing air. In the embodiment shown, that is, with the strip-like guide elements 22, these moreover ensure a smoothing out of the flow irregularities in the air leaving the fans, in the lengthwise direction of the outflow opening 6. So that although the air from the discrete outlet openings 20 of the fans 19 is fed to the guide elements from varying directions, an adjustment occurs such that the flat stream of air leaving the guide elements 22 has a great extent of uniformity in lengthwise direction.

The alternative embodiment shown in fig. 3 has parts which are identical to those shown in fig. 2. These identical parts are designated with the same reference numerals.

The embodiment in fig. 3 is distinguished in characteristic manner in that the guide elements 22 are assembled with a number of comb shaped supports 33 into a unit 30 which is mounted pivotally on an axis 31 in the housing 3. The strip-like slats 22 are joined to the unit 30 by bolts extending through these and through each of the comb shaped supports 33. The supports 33 are connected pivotally to the housing 3 using forks 32. The unit 30 can be swivelled in the manner indicated out of the drawn position, in which the stream of air is directed slightly slanting outward, to the position indicated by the dashed line, in which the stream of air is directed vertically downward. In practice the guide elements 22 are adjusted such that optimal flow conditions are created. When for instance a relatively lower pressure can occur inside the building than outside the building, which will usually have the consequence that the air curtain bends inward, the stream of air can initially be directed slightly outward.

Fig. 3 shows further the way in which the cover 4 grips onto the housing 3. The cover 4 is provided with a number of slot shaped openings 26 which drop over tongues 25 arranged on the housing 3.

Fig. 4 shows a selected number of possible different embodiments of the guide elements according to the invention. Characteristic for each of these embodiments is that outflow channels are defined which have in the general outflow direction, which is vertical in the examples shown, a lengthwise dimension which is a number of times greater than the smallest dimension transversely of this direction. As noted earlier this lengthwise dimension is at least five times as great as the transverse dimension. The degree of

turbulence of the outflowing air is reduced by these guide elements such that the interface with the outside air remains relatively "smooth", so that a minimum of mixing and diverting of the air of the air curtain to the outside takes place, while moreover the widening of the stream of air as the distance to the outflow opening increases is greatly limited, so that the flat stream of air extends further downward than when the degree of turbulence of the air is high.

It will be apparent that the device according to the invention does not necessarily need to have integrated air supply means. The invention can be applied just as well with an air curtain device wherein the air supply means are external.

Claims

1. Air curtain device (1) comprising a housing (3) for arrangement close to a passage opening in a building, which housing (3) is provided with an air outflow opening (6), air supply means (16) connected to said opening (6) and air guiding means for causing directed outflow out of said opening of the air supplied by said air supply means (16), said air guiding means comprising guide elements (22), defining multiple air outflow channels within the outflow opening (6), which have in the general outflow direction a lengthwise dimension that is a number of times greater than the smallest dimension transversely of this direction, **characterized in that**
 - the air outflow opening (6) is an elongate slot like opening extending immediately along a longitudinal side of the housing (3),
 - the outflow channels have a constant section in the outflow direction and in that
 - the lengthwise dimension of the outflow channels amounts to at least five times the transverse dimension.
2. Device as claimed in claim 1, **characterized in that** the guide elements are strip-like elements (22) extending in lengthwise direction of the elongate slot like air outflow opening (6) and parallel to each other.
3. Device as claimed in claim 2, **characterized in that** the air supply means comprise a number of adjacently disposed fans (16) with outlet openings lying at mutual intervals.
4. Device as claimed in claim 3, **characterized in that** between the outlet openings lying at intervals and the air outflow opening (6) transverse dividing surfaces (21) are arranged for distributing the air uniformly.

5

5. Device as claimed in any of the foregoing claims, **characterized in that** the guide elements are assembled into a separate unit (30) which can be pivoted around an axis in the lengthwise direction of the outflow opening (6).

Patentansprüche

10

1. Luftvorhangerät (1) mit einem Gehäuse (3), das dicht in einer Durchgangsöffnung eines Gebäudes einbaubar ist und mit einer Luftausströmöffnung (6) versehen ist, mit einer Luftzuführungseinrichtung (16), die an die Öffnung (6) angeschlossen ist, und mit Luftleitmitteln, die eine gerichtete Ausströmung aus der Luftöffnung bewirken, die von der Luftzuführungseinrichtung (16) gespeist wird, wobei die Luftführungsmittel Führungselemente (22) aufweisen, die in der allgemeinen Ausströmrichtung eine Längsdimension besitzen, die um ein Mehrfaches größer ist als die kleinste Dimension quer zu dieser Richtung, dadurch gekennzeichnet, daß

15

- die Luftauslaßöffnung (6) eine schlitzzartige, langgestreckte Öffnung ist, die sich unmittelbar über eine Längsseite des Gehäuses (3) erstreckt,
- die Ausströmkanäle einen konstanten Querschnitt in Ausströmrichtung aufweisen, und
- die Längsabmessung der Ausströmkanäle wenigstens fünfmal so groß ist wie die Querabmessung.

20

25

30

35

2. Gerät nach Anspruch 1, dadurch gekennzeichnet, daß die Führungselemente streifenartige Elemente (22) sind, die sich in Längsrichtung der langgestreckten, schlitzzartigen Luftausströmöffnung (6) und parallel zueinander erstrecken.

40

3. Gerät nach Anspruch 2, dadurch gekennzeichnet, daß die Luftzuführungseinrichtung mehrere benachbart zueinander angeordnete Gebläse (16) aufweist, deren Austrittsöffnungen in gegenseitigen Abständen angeordnet sind.

45

4. Gerät nach Anspruch 3, dadurch gekennzeichnet, daß zwischen den im Abstand zueinander liegenden Öffnungen und der Luftausströmöffnung (6) quer verlaufende Unterteilungsoberflächen (21) vorgesehen sind, um die Luft gleichförmig zu verteilen.

50

5. Gerät nach einem der vorhergehenden Ansprüche, dadurch gekennzeichnet, daß die Führungselemente zu einer getrennten Einheit (30) zusam-

mengebaut sind, die um eine Achse verschwenkt werden kann, die in Längsrichtung der Ausströmöffnung (6) verläuft.

Revendications

1. Dispositif formant rideau d'air (1) comprenant un carter (3) prévu pour être placé à proximité d'une ouverture formant passage ménagée dans un bâtiment, lequel carter (3) est pourvu d'une ouverture prévue pour la sortie d'air (6), des moyens d'alimentation en air (16) raccordés à ladite ouverture (6) et des moyens de guidage de l'air pour assurer la sortie d'air fourni par lesdits moyens d'alimentation en air (16) par ladite ouverture prévue pour la sortie d'air, lesdits moyens de guidage de l'air comprenant des éléments de guidage (22), définissant de multiples canaux prévus pour la sorties de l'air à l'intérieur de l'ouverture prévue pour la sortie d'air (6), qui présentent, dans le sens général de la sortie d'air, une dimension, dans le sens de la longueur, égale à plusieurs fois la plus petites dimension transversales par rapport à cette longueur, **caractérisée en ce que**
 - l'ouverture prévue pour la sortie d'air (6) est une ouverture allongée de type fente s'étendant immédiatement le long d'un côté longitudinal du carter (3).
 - les canaux de sortie d'air présentent une section constante dans le sens de la sortie d'air, et en ce que
 - la dimension, dans le sens de la longueur, des canaux prévus pour la sortie d'air, est égale à au moins cinq fois la dimension transversale.
2. Dimension selon la revendication 1, **caractérisée en ce que** les éléments de guidage sont des éléments de type bandeaux (22) s'étendant dans le sens de la longueur de l'ouverture allongée de type fente, prévue pour la sortie d'air (6) et parallèles les uns aux autres.
3. Dispositif selon la revendication 2, **caractérisé en ce que** les moyens d'alimentation en air comprennent plusieurs ventilateurs (16) adjacents avec des ouvertures prévues pour l'échappement, séparées les unes des autres par des intervalles.
4. Dispositif selon la revendication 3, **caractérisé en ce que**, entre les ouvertures prévues pour l'échappement d'air, séparées les unes des autres par des intervalles, et l'ouverture prévue pour la sortie d'air (6) des surfaces de division transversales (21) sont prévues pour assurer la répar-

tition uniforme de l'air.

5. Dispositif selon l'une quelconque des revendications précédentes, **caractérisé en ce que** les éléments de guidage sont assemblés de manière à constituer un ensemble séparé (30) qui peut pivoter autour d'un axe, dans le sens de la longueur de l'ouverture prévues pour la sortie d'air (6).

5

10

15

20

25

30

35

40

45

50

55

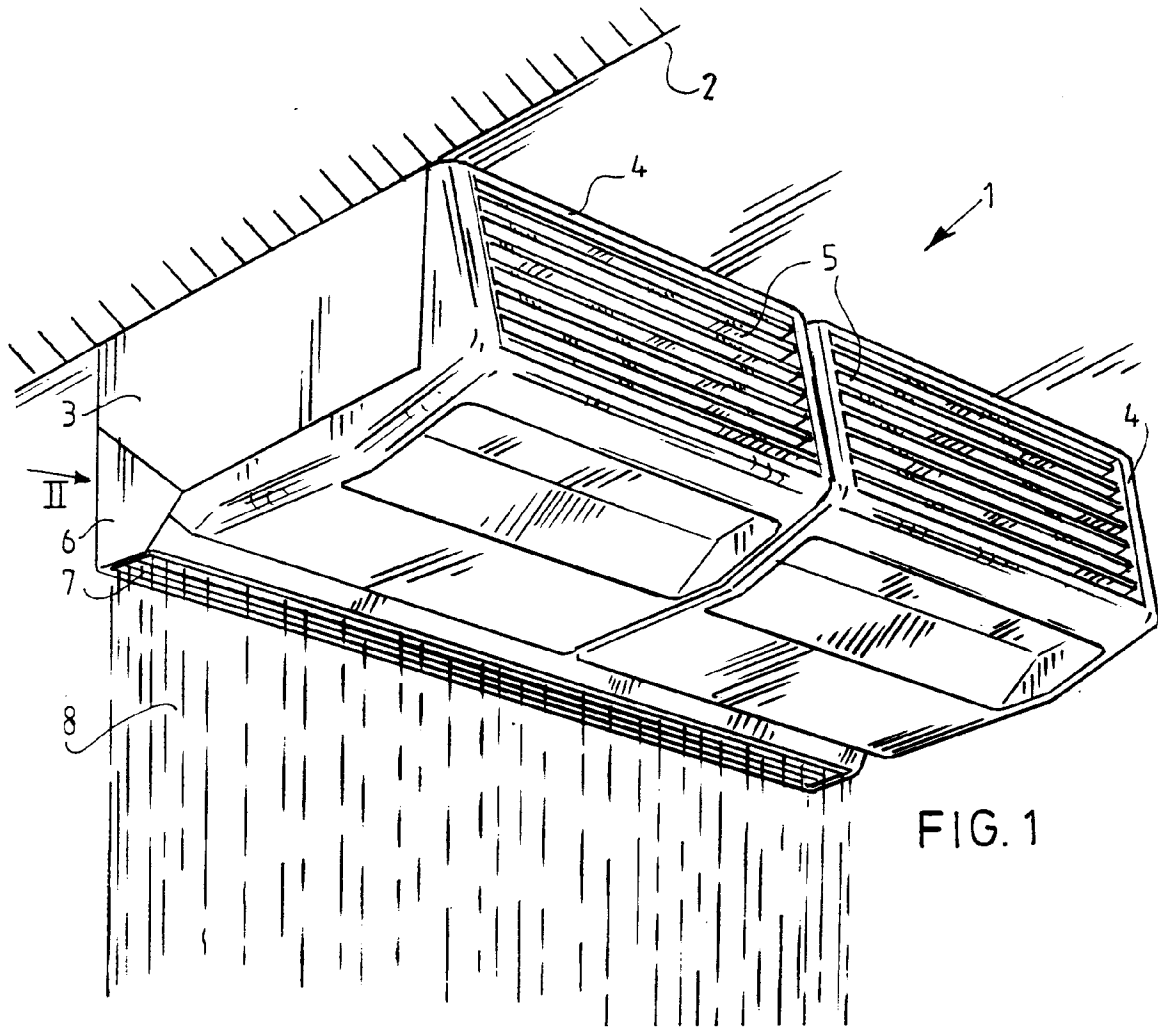

FIG. 1

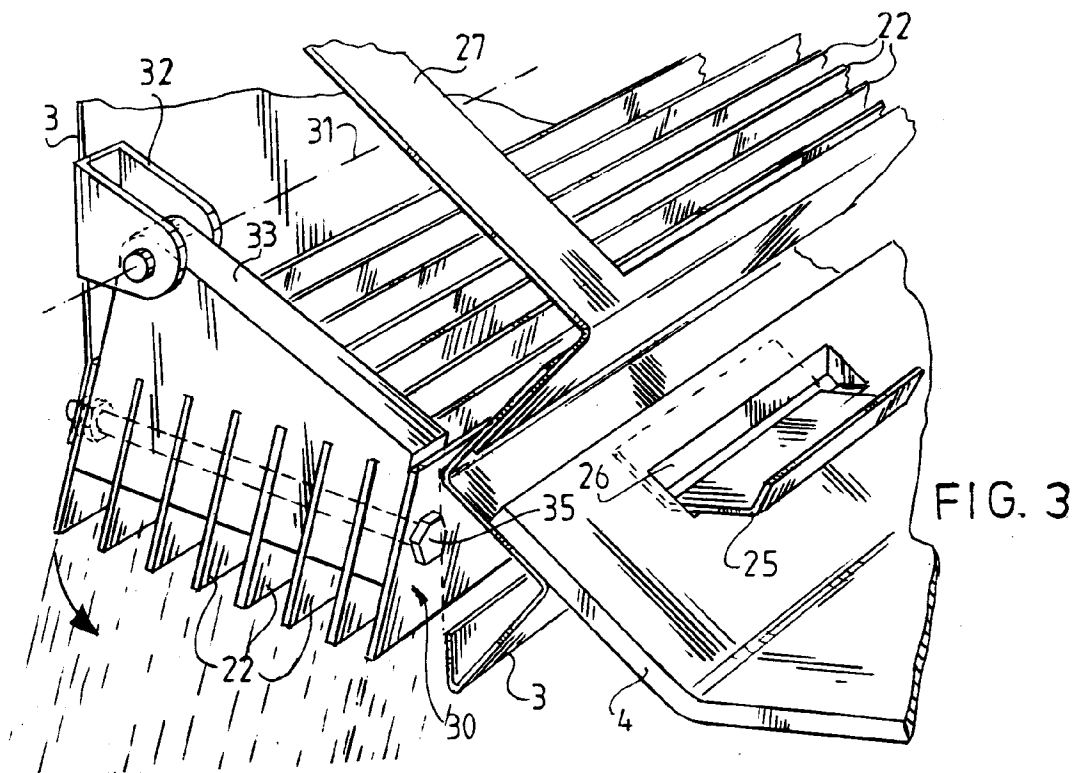

FIG. 3

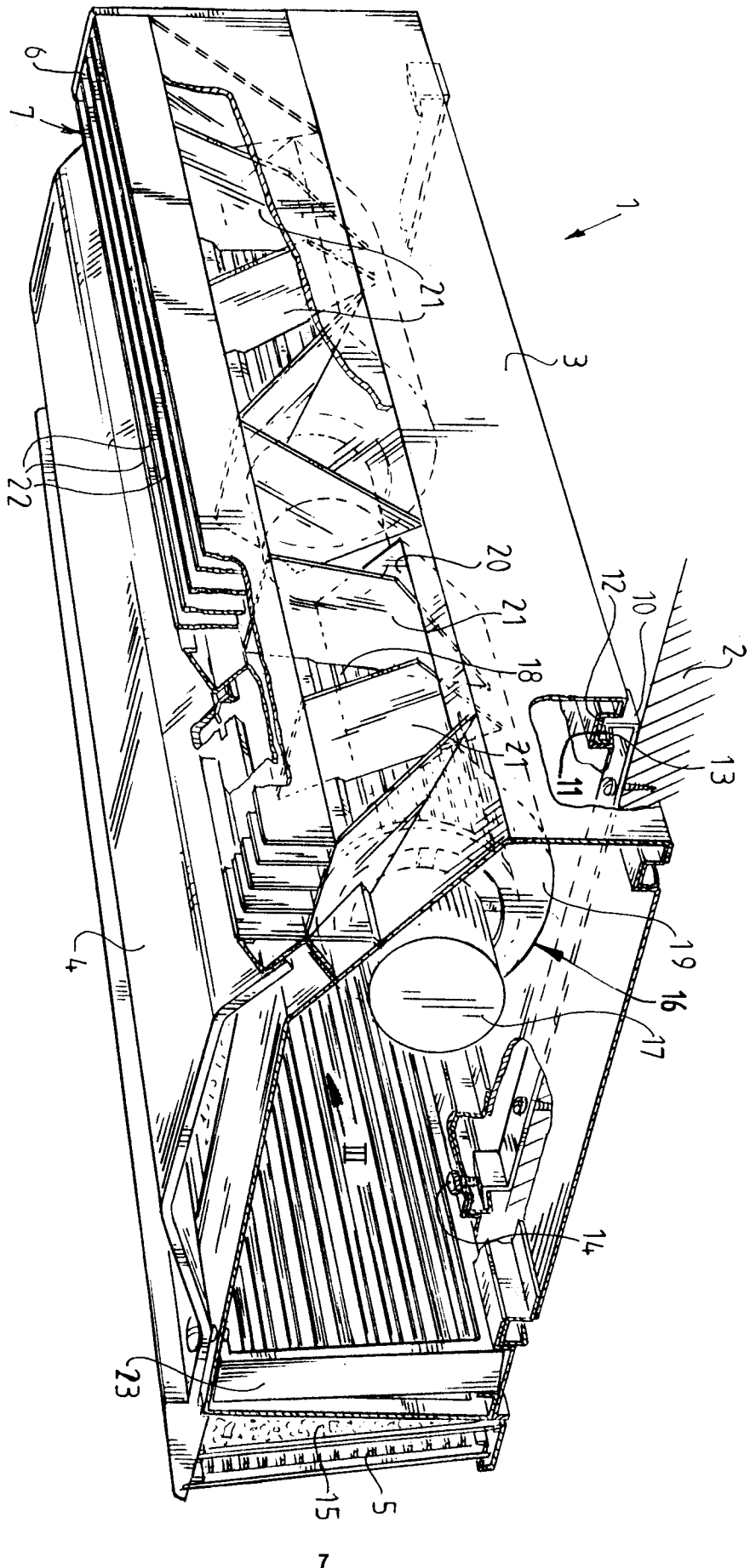

FIG. 2

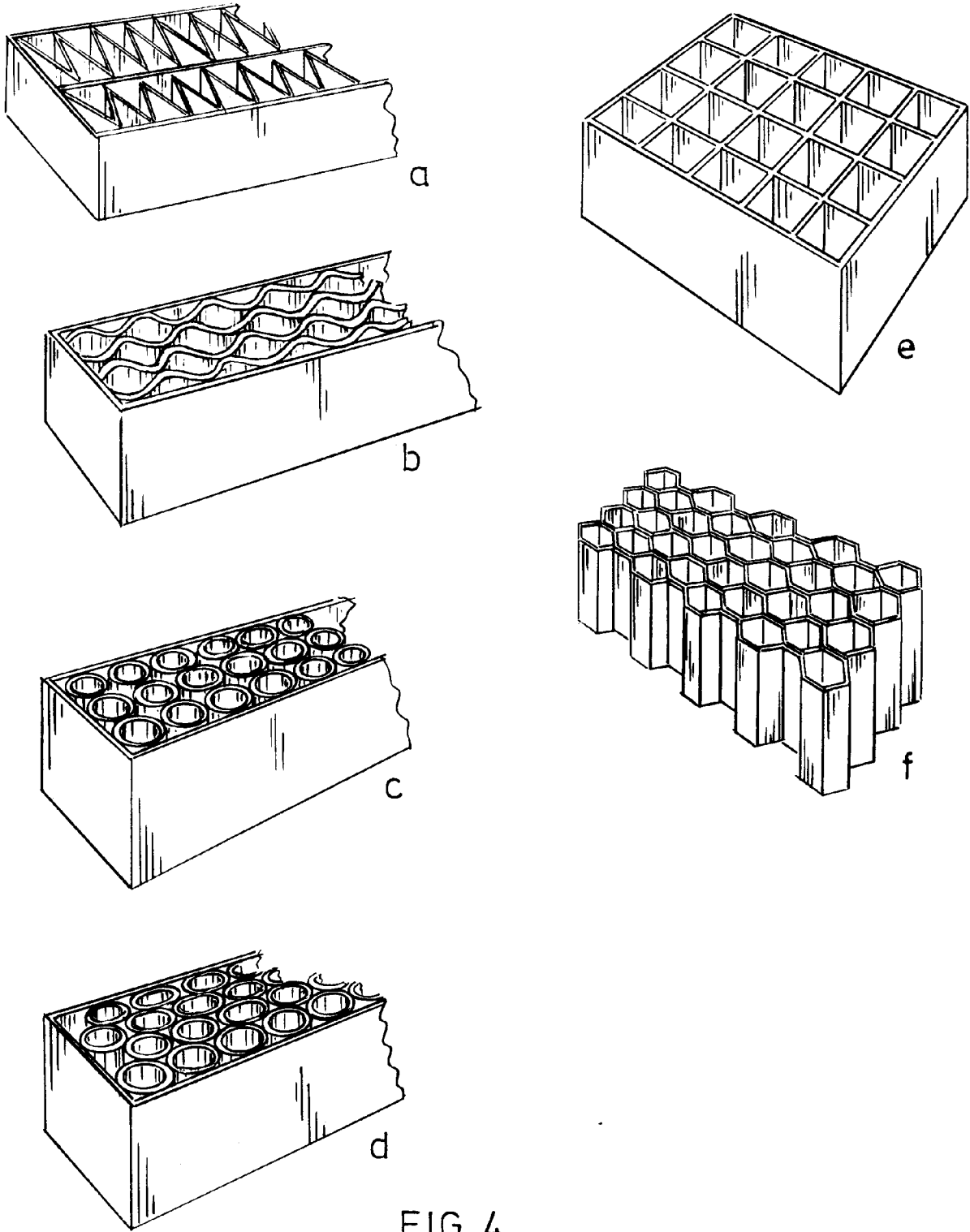

FIG. 4