



- (51) **International Patent Classification:**  
A47L 9/04 (2006.01)
- (21) **International Application Number:**  
PCT/EP2013/058852
- (22) **International Filing Date:**  
29 April 2013 (29.04.2013)
- (25) **Filing Language:** English
- (26) **Publication Language:** English
- (71) **Applicant:** AKTIEBOLAGET ELECTROLUX  
[SE/SE]; S:t Göransgatan 143, S-105 45 Stockholm (SE).
- (72) **Inventor:** ERIKSSON, Henrik; c/o AB Electrolux, S:t  
Göransgatan 143, S-105 45 Stockholm (SE).
- (74) **Agent:** BODIN, Henrik; AB Electrolux, Group IP, S:t  
Göransgatan 143, S-105 45 Stockholm (SE).
- (81) **Designated States** (unless otherwise indicated, for every  
kind of national protection available): AE, AG, AL, AM,  
AO, AT, AU, AZ, BA, BB, BG, BH, BN, BR, BW, BY,

BZ, CA, CH, CL, CN, CO, CR, CU, CZ, DE, DK, DM,  
DO, DZ, EC, EE, EG, ES, FI, GB, GD, GE, GH, GM, GT,  
HN, HR, HU, ID, IL, IN, IS, JP, KE, KG, KM, KN, KP,  
KR, KZ, LA, LC, LK, LR, LS, LT, LU, LY, MA, MD,  
ME, MG, MK, MN, MW, MX, MY, MZ, NA, NG, NI,  
NO, NZ, OM, PA, PE, PG, PH, PL, PT, QA, RO, RS, RU,  
RW, SC, SD, SE, SG, SK, SL, SM, ST, SV, SY, TH, TJ,  
TM, TN, TR, TT, TZ, UA, UG, US, UZ, VC, VN, ZA,  
ZM, ZW.

- (84) **Designated States** (unless otherwise indicated, for every  
kind of regional protection available): ARIPO (BW, GH,  
GM, KE, LR, LS, MW, MZ, NA, RW, SD, SL, SZ, TZ,  
UG, ZM, ZW), Eurasian (AM, AZ, BY, KG, KZ, RU, TJ,  
TM), European (AL, AT, BE, BG, CH, CY, CZ, DE, DK,  
EE, ES, FI, FR, GB, GR, HR, HU, IE, IS, IT, LT, LU, LV,  
MC, MK, MT, NL, NO, PL, PT, RO, RS, SE, SI, SK, SM,  
TR), OAPI (BF, BJ, CF, CG, CI, CM, GA, GN, GQ, GW,  
ML, MR, NE, SN, TD, TG).

**Published:**

— with international search report (Art. 21(3))

- (54) **Title:** NOZZLE FOR A VACUUM CLEANER AND VACUUM CLEANER

FIG 1

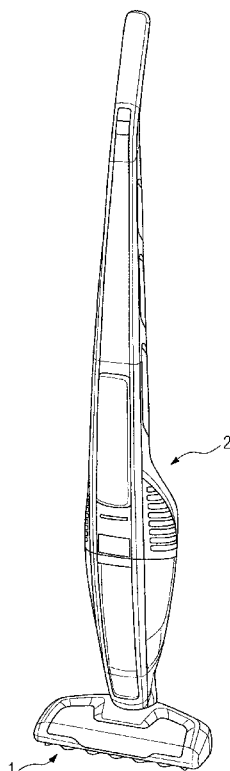

(57) **Abstract:** The invention relates to a nozzle (1) for a vacuum cleaner (2), the nozzle (1) comprising - a rotatable member (3) for picking up particles from a surface to be cleaned, the rotatable member (3) being arranged around a longitudinal axis (10) and being actuated by a motor (20) in order to rotate around said longitudinal axis (10), and - a cleaning arrangement for removing articles entangled to the rotatable member (3) in a cleaning procedure comprising at least one cleaning member (5) wherein the distance between the cleaning member (5) and the rotatable member (3) is variable to achieve a first state in which the cleaning member is arranged at a distance from the rotatable member (3) and a second state in which the cleaning member (5), during rotation of the rotatable member (3), cooperates with the rotatable member (3) in order to remove debris from the rotatable member (3), wherein the nozzle (1) comprises a sensor element (30) adapted to detect the temperature of at least one nozzle element in order to avoid an overload situation during the cleaning procedure.

NOZZLE FOR A VACUUM CLEANER AND VACUUM CLEANER

The present invention relates generally to the field of vacuum cleaners. More specifically, the present invention is related to  
5 a vacuum cleaner comprising a nozzle with a rotatable brush and a cleaning arrangement for cleaning said rotatable brush.

## BACKGROUND OF THE INVENTION

10 In vacuum cleaning nozzles provided with a rotatable member, i.e. a rotatable brush roll, it is known that threads, lint, human or animal hairs or any other fibrous material tend to adhere to the brush roll during operation of the vacuum cleaner. This may worsen the functionality of the cleaning nozzle.

15 WO 2009/117383 A2 discloses a cleaning nozzle for a vacuum cleaner comprising a rotary brush and one or more cleaning members for removing debris that has been wrapped around the rotary brush. The cleaning members are positioned adjacent the rotary  
20 brush and are adapted to move between a resting position and a cleaning position, and are arranged to clean the rotary brush during rotation of the brush. The cleaning nozzle comprises an overload mechanism which is adapted to monitor the current of an electric motor which applies a torque to the brush roll. Micro-  
25 controller is used to monitor the current of the electric motor and to compare said current to a threshold value. If this threshold value is exceeded for certain period of time, the motor is switched off in order to prevent damage of the motor due to high heats that will occur if the motor is operated over cer-  
30 tain period of time higher than the expected torque value.

A drawback of the known vacuum cleaning nozzle is that measuring the current of the motor may sometimes lead to distorted information regarding the load situation of the motor, i.e. the point  
35 of time at which the overload mechanism is activated may be inappropriate. Accordingly, there is a need for improvements regarding the activation of the overload mechanism.

## SUMMARY OF THE INVENTION

It is an objective of embodiments of the invention to provide  
5 for an improved nozzle for a vacuum cleaner, an improved vacuum  
cleaner and a method for determining an overload situation dur-  
ing a cleaning procedure of a vacuum cleaner in order to improve  
the activation of the overload mechanism. The objective is  
solved by the features of the independent claims. Preferred em-  
10 bodiments are given in the dependent claims. If not explicitly  
indicated otherwise, embodiments of the invention can be freely  
combined with each other.

The invention is intended for battery powered vacuum cleaners as  
15 well as mains-operated vacuum cleaners. The nozzle according to  
the present invention is further envisaged for robotic vacuum  
cleaners.

According to a first aspect of the invention, the invention re-  
20 lates to a nozzle for a vacuum cleaner, the nozzle comprising

- a rotatable member for picking up particles from a surface to  
be cleaned, the rotatable member being arranged around a lon-  
gitudinal axis and being actuated by a motor in order to ro-  
tate around said longitudinal axis, and
- 25 - a cleaning arrangement for removing articles entangled to the  
rotatable member in a cleaning procedure comprising at least  
one cleaning member wherein the distance between the cleaning  
member and the rotatable member is variable to achieve a  
first state in which the cleaning member is arranged at a  
30 distance from the rotatable member and a second state in  
which the cleaning member, during rotation of the rotatable  
member, cooperates with the rotatable member in order to re-  
move debris from the rotatable member,

wherein the nozzle comprises at least one sensor element adapted  
35 to detect the temperature of at least one nozzle element in or-  
der to avoid an overload situation during the cleaning proce-  
dure.

The nozzle element may be the rotatable member, the cleaning member, the motor applying a torque to the rotatable member or any other nozzle element which is heated during the cleaning procedure. By means of the sensor element it is possible to accurately determine the temperature of said nozzle element thereby deriving information regarding the thermal load of said nozzle element. The information may be used to control or interrupt the cleaning procedure if the thermal load exceeds a predefined threshold. Thereby a more accurate detection of an overload situation is achieved.

According to preferred embodiments, the sensor element is a temperature sensor being located on or integrated in the housing of the motor. During the cleaning procedure the motor is heated by means of the electric power consumed by the electric motor in order to apply the necessary torque to the rotatable member of the nozzle. In order to avoid an overheating of the motor, the temperature sensor may generate a signal depending on the temperature of the motor. Said signal may be used to detect an overload situation which may damage the motor.

According to preferred embodiments, the sensor element is a temperature sensor being located on or integrated in the cleaning member. Also the cleaning member is exposed to thermal load during the cleaning procedure. By means of the temperature sensor monitoring the temperature of the cleaning member it is possible to determine not only the load of the cleaning member but also the load of the electric motor powering the rotatable member of the nozzle thereby effecting the heating of the cleaning member. In other words, the heating of the cleaning member is coupled with the load of the motor and therefore may be used to detect an overload situation.

According to preferred embodiments, the nozzle comprises at least two sensor elements which are adapted to measure the temperature of different nozzle elements, e.g. the motor and the

cleaning member. The signals generated by the two sensor elements are provided to an electric overload detection circuit wherein the determination of an overload situation within the electric overload detection circuit is based on both signals.

5

According to preferred embodiments, the sensor element comprises a resistor varying its resistance value as a function of the resistor temperature. The temperature sensor may be a resistor with a negative temperature coefficient (NTC) or with a positive  
10 temperature coefficient (PTC). The resistor may be applied with a fixed electric current, wherein the voltage across the resistor corresponds to the temperature of the resistor. Thereby a cost-effective measurement of the temperature of the nozzle element may be provided.

15

According to preferred embodiments, the sensor element is thermally conductively connected to the nozzle element. Thereby the thermal coupling between the nozzle element and the sensor element is optimized. Preferably, a heat-transfer paste or thermally  
20 conductive paste may be used to connect the sensor element with the nozzle element.

According to preferred embodiments, the sensor element is a temperature sensor being spatially separated from the nozzle element and adapted for remote sensing the temperature of said  
25 nozzle element. The temperature sensor may comprise a sensing area adapted to receive thermal radiation of the nozzle element to be monitored thereby deriving a signal correlated to the temperature of the nozzle element. Said signal may be used in the overload detection circuit for detecting an overload situation. Advantageously, using the remote-sensing sensor element there is  
30 no need for a coupling of the nozzle element to be monitored and the sensor element, so, also the temperature of fast moving nozzle elements, for example rotatable members like the brush roll  
35 may be temperature monitored.

According to preferred embodiments, the sensor element is a thermal infrared sensor. Thereby the terminal radiation in the infrared range may be monitored.

5 According to preferred embodiments, the sensor element is connected to an overload detection circuit adapted to receive and analyse a signal value associated with or proportional to the temperature of the nozzle element provided by the sensor element. The overload detection circuit may be integrated in the  
10 nozzle or the nozzle comprises an interface for providing the signal value to another part of the vacuum cleaner which comprises said overload detection circuit. By means of said overload detection circuit the signal value provided by the sensor element is analysed in order to decide whether an overload  
15 situation occurred.

According to a further aspect, the invention relates to a vacuum cleaner comprising a nozzle configured according to an embodiment described above.

20 According to preferred embodiments, the vacuum cleaner may comprise an overload detection circuit adapted to receive a signal value associated with or proportional to the temperature of the nozzle element. The overload detection circuit may be assembled  
25 within an upper housing of the vacuum cleaner and coupled via electrical lines with the nozzle in order to receive information correlated to the temperature of the nozzle element.

30 According to preferred embodiments, the overload detection circuit is adapted to compare the signal value associated with or proportional to the temperature with a threshold value defining the threshold between normal cleaning operation and an overload situation. If the temperature is below the threshold value there is no risk of a damage of the motor or another nozzle element  
35 due to overheating. However, if the temperature is equal to or rises above said threshold value, the cleaning operation has to

be terminated in order to avoid a damage of the vacuum cleaner nozzle.

According to preferred embodiments, the detection circuit is operatively connected to a power switching module adapted to terminate the operation of the motor if the signal value associated with or proportional to the temperature exceeds the threshold value in order to avoid a damage of nozzle.

According to a further aspect, the invention relates to a method for determining an overload situation during a cleaning procedure of a vacuum cleaner, the vacuum cleaner comprising

- a nozzle with a rotatable member for picking up particles from a surface to be cleaned; and
- a cleaning arrangement within the nozzle for removing articles entangled to the rotatable member in a cleaning procedure in order to remove any entangled articles from the rotatable member;

the method comprising the steps of

- generating a signal value associated with or proportional to the temperature of at least one nozzle element during the cleaning procedure by means of a sensor element (30);
- comparing said signal value with a threshold value in order to detect an overload situation during the cleaning procedure; and
- terminating the cleaning procedure if the signal value associated with or proportional to the temperature of at least one nozzle element exceeds the threshold value in order to avoid a damage of the vacuum cleaner.

According to preferred embodiments, the signal value associated with or proportional to the temperature of at least one nozzle element is measured directly on or in the nozzle element using a sensor element attached to or integrated in the nozzle element.

Advantageously, the nozzle element is thermally coupled with the sensor element in order to transfer the heat to the sensor ele-

ment. Thereby a cost-effective measurement of the temperature of the nozzle element is provided.

According to other embodiments, the signal value associated with or proportional to the temperature of at least one nozzle element is measured indirectly using a remote sensor element which is spatially separated from the nozzle element. Using a remote sensor enables the monitoring of the temperature of a moving element, e.g. the brush roll, in order to use the temperature information of said moving element for detecting an overload situation.

#### BRIEF DESCRIPTION OF THE DRAWINGS

- The various aspects of the invention, including its particular features and advantages, will be readily understood from the following detailed description and the accompanying drawings, in which:
- Fig. 1 shows a vacuum cleaner with a nozzle comprising a rotatable brush roll;
- Fig. 2 shows a vacuum cleaner with a nozzle comprising a rotatable brush roll;
- Fig. 3 shows a rotatable brush roll and a cleaning member being positioned in a resting position;
- Fig. 4 shows a rotatable brush roll, a cleaning member being positioned in a cleaning position and a motor comprising a temperature sensor;
- Fig. 5 shows a rotatable brush roll, a cleaning member being positioned in a cleaning position and a temperature sensor located on the cleaning member; and
- Fig. 6 shows a rotatable brush roll, a cleaning member being positioned in a cleaning position and a remote-sensing temperature sensor for analysing the temperature of the brush roll.

## DETAILED DESCRIPTION OF PREFERRED EMBODIMENTS

5 The present invention will now be described more fully with reference to the accompanying drawings, in which example embodiments are shown. However, this invention should not be construed as limited to the embodiments set forth herein. Throughout the following description similar reference numerals have been used to denote similar elements, parts, items or features, when applicable.  
10

Fig. 1 illustrates a vacuum cleaner 2 comprising a nozzle 1 provided with a rotatable member 3 for picking up particles from a surface to be cleaned. The rotatable member 3, also referred to  
15 as brush roll is drivingly coupled to a motor 20 (not shown in Fig. 1). By means of the motor 20, the rotatable member 3 is rotated around its longitudinal axis 10 in order to treat the surface to be cleaned. The motor 20 may be an electric motor, i.e. an AC or DC motor.  
20

The nozzle 1 is further provided with a cleaning arrangement for removing articles entangled to the rotatable member 3. Said articles may be debris that has been wrapped around the rotatable member 3, e.g. threads, lint, hairs or any other fibrous material. The user may initiate the cleaning procedure of the rotatable member 3 by pushing a push button 6 on the nozzle 1  
25 thereby engaging the cleaning arrangement.

Fig. 2 - 6 show the nozzle 1 or parts of the nozzle 1 of the vacuum cleaner 2 more in detail. The cleaning arrangement comprises a cleaning member 5 being movable between a resting position in which the cleaning member 5 is arranged at a distance from the rotatable member 3 and a cleaning position in which the cleaning member is in contact with the rotatable member 3. For  
30 example, the movement from the resting position to the cleaning position is effected by the push button 6.  
35

The rotatable member 3 may comprise a support surface 4 provided on a radially projecting member 8 of the rotatable member 3. In the embodiments shown in Fig. 2 - 6, two projecting members 8 are helically arranged along a longitudinal axis of the rotatable member 3. Other possible alternatives may be a single helically arranged projecting member 8, or more than two helically arranged projecting members 8.

The cleaning position may be arranged stepwise or gradually, thus enabling the cleaning member 5 to approach the support surface 4 during cleaning action. This might be advantageous for example if a thick layer of entangled articles are present, or if the power available for driving the rotatable member 3 is limited. A push button 6, connected via a linking mechanism shaft to a cleaning member 5, is provided to move the cleaning member 5 between the resting position and the cleaning position.

In the cleaning position (Fig. 4 - 6), a resilient sheet member 7 of the cleaning member 5 cooperates with the support surface 4 during rotation of the rotatable member 3 to remove any entangled articles from the rotatable member 3. The resilient sheet member 7 is capable of providing a resilient contact with the support surface 4 in the cleaning position during rotation of the rotatable member 3. Thereby, the possible slow down of the rotational speed of the rotatable member 3 due to the cleaning action will be limited if there is a lot of entangled articles to be removed.

When in use, the cleaning arrangement works as follows. During brush roll cleaning the cleaning member 5 will interact and apply pressure on a support surface 4 provided on the rotatable member 3 provided in the nozzle 1 of a vacuum cleaner. During the cleaning process, the motor fan of the vacuum cleaner is also turned on. The support surface 4 is the only area of the brush roll, apart from the bristles, that will be in contact with the cleaning member 5 during a cleaning process. For a full revolution of the brush roll, the entire support surface 4 will

have been in contact with the cleaning member 5 and therefore will any entangled article be exposed to the cleaning interaction in between these parts. Entangled articles will get torn into smaller pieces by the tearing, or friction, caused by the cleaning member 5 at the support surface. These torn articles may be separated from the brush roll by the airflow of the vacuum cleaner in combination with centrifugal force due to the rotational movement of the brush roll and will end up in the dust container or dust bag of the vacuum cleaner.

10

As may be apparent for a person skilled in the art, the rotating member cleaning performance is dependent on the rotational speed of the rotating member 3 and the pressure imposed by the cleaning member 5, respectively, the resilient sheet member 7 upon the rotating member 3. An increase of the cleaning performance of the rotating member 3 is directly coupled with an increase of the load of the motor 20 powering the rotating member 3. For optimizing the cleaning performance, the motor may be powered at maximum load.

20

In order to prevent damage to the motor 20 or other parts of the nozzle 1, there may be at least one sensor element 30 within the nozzle 1 which is adapted to determine the thermal load of at least one nozzle element which is getting heated during cleaning procedure. The sensor element 30 may continuously or periodically derive a signal value associated with or proportional to the temperature of the nozzle element thereby measuring the thermal load of said nozzle element. The nozzle 1 or the vacuum cleaner 2 may comprise an electric overload detection circuit which is adapted to receive the signal value associated with or proportional to the temperature of the nozzle element and compare said signal value to a threshold value. The threshold value is associated with a maximum thermal load, said nozzle element is able to tolerate. The overload detecting circuit may be adapted to control the electric power supply of the motor 20. The power supply line of the motor 20 may be interrupted if the threshold value has been exceeded thereby switching off the

35

electric motor 20. In other words, the electric overload detection circuit is configured to detect the temperature of the nozzle element by means of the temperature sensor and configured to terminate the operation of the electric motor 20 if said temperature of the nozzle element rises above a certain level which is pre-defined by the threshold value. Preferably, the overload detection circuit is only operational during the cleaning procedure and deactivated during normal operation of the vacuum cleaner 2.

Preferably, the sensor element 30 is a temperature sensor which is located on or integrated in the nozzle element which temperature is being monitored. Preferably, the nozzle element is the motor 20 and the temperature sensor is placed on or in the housing of the motor 20 (Fig. 3, 4). According to other embodiments, the temperature sensor is placed on or in the cleaning member 5 (Fig. 5) or the resilient sheet member 7. The temperature of the cleaning member 5 or the resilient sheet member 7 is indicative for the load of the motor 20, because the friction between the rotatable member 3, e.g. the brush roll and the cleaning member 5 or the resilient sheet member 7 is generating the heat at said cleaning member 5, respectively, the resilient sheet member 7, wherein the electrical power consumed by the motor 20 is proportional to said friction. Therefore, there is direct relationship between the temperature of the cleaning member 5 or the resilient sheet member 7 and the load of the motor 20.

The sensor element 30 may be formed by a temperature dependent resistor. The resistor may be configured to vary its resistance value according to the temperature of the resistor. In order to transfer the thermal energy from said nozzle element to the sensor element 30 in an optimal way, the sensor element 30 may be thermally conductively connected to the nozzle element, e.g. via the heat-conductive paste.

Instead of directly connecting the sensor element 30 on or inside the nozzle element to be thermally monitored, the sensor

element 30 may be a remote-sensing temperature sensor which is spatially separated from the nozzle element (Fig. 6). The remote-sensing temperature sensor may have a sensing area adapted to receive thermal radiation of the nozzle element and adapted to generate a signal being dependent, e.g. proportional to the received thermal radiation. Thereby it is possible to determine the temperature of moving nozzle elements, e.g. the rotatable brush roll. The remote-sensing temperature sensor may be any sensor being adapted to determine the temperature of the nozzle element remotely, preferably a thermal infrared sensor.

In the following, a method for determining an overload situation of the vacuum cleaner 2 during the cleaning procedure is described. During normal operation of the vacuum cleaner 2, debris adhere to the rotatable member 3. In order to remove said debris, the user may perform a cleaning procedure during which the debris is removed from the rotatable member 3. The cleaning member 5 comprising the resilient sheet member 7 may be moved from the resting position (Fig. 3) into the cleaning position in which the resilient sheet member 7 engages the rotatable member 3 to remove debris therefrom. As already mentioned above, said movement may be caused by activating the push button 6. During the cleaning procedure the electric motor 20 applies a torque to the rotatable member 3 in order to effect a movement of the rotatable member relative to the cleaning member 5, respectively, the resilient sheet member 7.

The cleaning procedure may only take a short period of time in comparison to normal operation of the vacuum cleaner 2, e.g. 10-60 sec, preferably 20-40 sec. Therefore it is possible to operate the electric motor 20 at a higher electric power compared to normal operation. To avoid an overload of the electric motor 20, the sensor element 30 is configured to generate a signal value associated with or proportional to the temperature of at least one nozzle element which is getting heated during the cleaning procedure. The nozzle element may be, for example, the rotating member 3, the cleaning member 5, respectively, the resilient

sheet member 7 or the motor 20 itself. The signal value may be an electric current value or an electric voltage value. Said signal value may be provided to an electric overload load detection circuit. Within the overload detection circuit, the signal value may be compared to a threshold value indicating a maximum temperature of the nozzle element which should not be exceeded to avoid a damage of the vacuum cleaner 2, respectively, the nozzle 1. The overload detection circuit may be operatively connected to an electric power switching module which is adapted to interrupt the power supply of the electric motor 20 in order to terminate the operation of said motor 20, if the threshold value has been exceeded.

The temperature of the nozzle element may be measured directly at or in said nozzle element by means of a temperature sensor attached or integrated in said nozzle element. Alternatively, the temperature sensor may be a remote-sensing temperature sensor, i.e. the temperature is measured indirectly by detecting the thermal radiation caused by the nozzle element to be monitored. Thereby it's possible to gather the temperature of moving nozzle elements e.g. the rotatable member 3.

**List of reference numerals**

	1	nozzle
	2	vacuum cleaner
5	3	rotatable member
	4	support surface
	5	cleaning member
	6	push button
	7	resilient sheet member
10	8	radially projecting member
	10	longitudinal axis
	20	motor
	30	sensor element
15		

**Claims**

1. Nozzle (1) for a vacuum cleaner (2), the nozzle (1) comprising
- 5 - a rotatable member (3) for picking up particles from a surface to be cleaned, the rotatable member (3) being arranged around a longitudinal axis (10) and being actuated by a motor (20) in order to rotate around said longitudinal axis (10), and
- 10 - a cleaning arrangement for removing articles entangled to the rotatable member (3) in a cleaning procedure comprising at least one cleaning member (5) wherein the distance between the cleaning member (5) and the rotatable member (3) is variable to achieve a first state in which the cleaning member is
- 15 arranged at a distance from the rotatable member (3) and a second state in which the cleaning member (5), during rotation of the rotatable member (3), cooperates with the rotatable member (3) in order to remove debris from the rotatable member (3),
- 20 **characterised in that,**
- the nozzle (1) comprises at least one sensor element (30) adapted to detect the temperature of at least one nozzle element in order to avoid an overload situation during the cleaning procedure.
- 25
2. Nozzle according to claim 1, wherein the sensor element (30) is a temperature sensor being located on or integrated in the housing of the motor (20).
- 30 3. Nozzle according to claim 1, wherein the sensor element (30) is a temperature sensor being located on or integrated in the cleaning member (5).
4. Nozzle according to one of the preceding claims, wherein the
- 35 sensor element (30) comprises a resistor varying its resistance value as a function of the resistor temperature.

5. Nozzle according to one of the preceding claims, wherein the sensor element (30) is thermally conductively connected to the nozzle element.
- 5 6. Nozzle according to claim 1, wherein the sensor element (30) is a temperature sensor being spatially separated from the nozzle element and adapted for remote sensing the temperature of said nozzle element.
- 10 7. Nozzle element according to claim 6, wherein the sensor element (30) is a thermal infrared sensor.
8. Nozzle element according to one of the preceding claims, wherein the sensor element (30) is connected to an overload  
15 detection circuit adapted to receive and analyse a signal value associated with or proportional to the temperature of the nozzle element provided by the sensor element (30).
9. A vacuum cleaner provided with a nozzle according to one of  
20 the preceding claims 1-8.
10. Vacuum cleaner according to claim 9, comprising an overload detection circuit adapted to receive a signal value associated with or proportional to the temperature of the nozzle  
25 element (30).
11. Vacuum cleaner according to claim 10, wherein the overload detection circuit is adapted to compare the signal value associated with or proportional to the temperature with a  
30 threshold value defining the threshold between normal cleaning operation and an overload situation.
12. Vacuum cleaner according to claim 11, wherein the detection  
35 circuit is operatively connected to a power switching module adapted to terminate the operation of the motor (20) if the signal value associated with or proportional to the tempera-

ture exceeds the threshold value in order to avoid a damage of the nozzle (1).

13. Method for determining an overload situation during a cleaning procedure of a vacuum cleaner (2), the vacuum cleaner (2) comprising

- a nozzle (1) with a rotatable member (3) for picking up particles from a surface to be cleaned; and
- a cleaning arrangement within the nozzle (1) for removing articles entangled to the rotatable member (3) in a cleaning procedure in order to remove any entangled articles from the rotatable member (3)

the method comprising the steps of

- generating a signal value associated with or proportional to the temperature of at least one nozzle element during the cleaning procedure by means of a sensor element (30);
- comparing said signal value with a threshold value in order to detect an overload situation during the cleaning procedure; and
- terminating the cleaning procedure if the signal value associated with or proportional to the temperature of at least one nozzle element exceeds the threshold value in order to avoid a damage of the vacuum cleaner (2).

14. Method according to claim 13, wherein the signal value associated with or proportional to the temperature of at least one nozzle element is measured directly on or in the nozzle element using a sensor element (30) attached to or integrated in the nozzle element.

15. Method according to claim 13, wherein the signal value associated with or proportional to the temperature of at least one nozzle element is measured indirectly using a remote sensor element (30) which is spatially separated from the nozzle element.

1/4

FIG 1

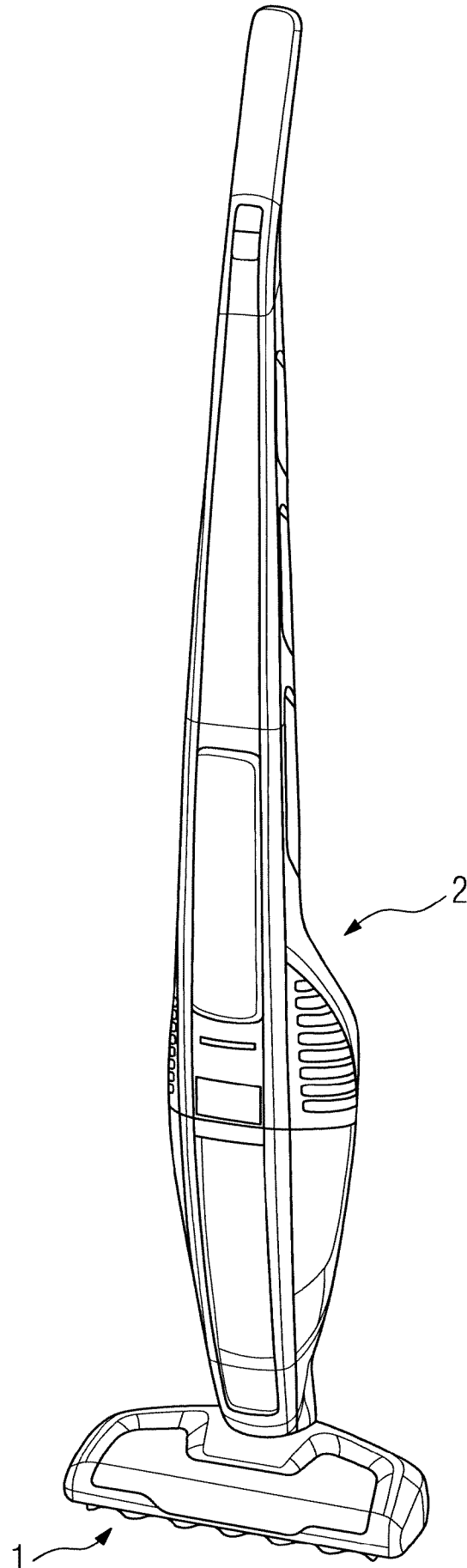

FIG 2

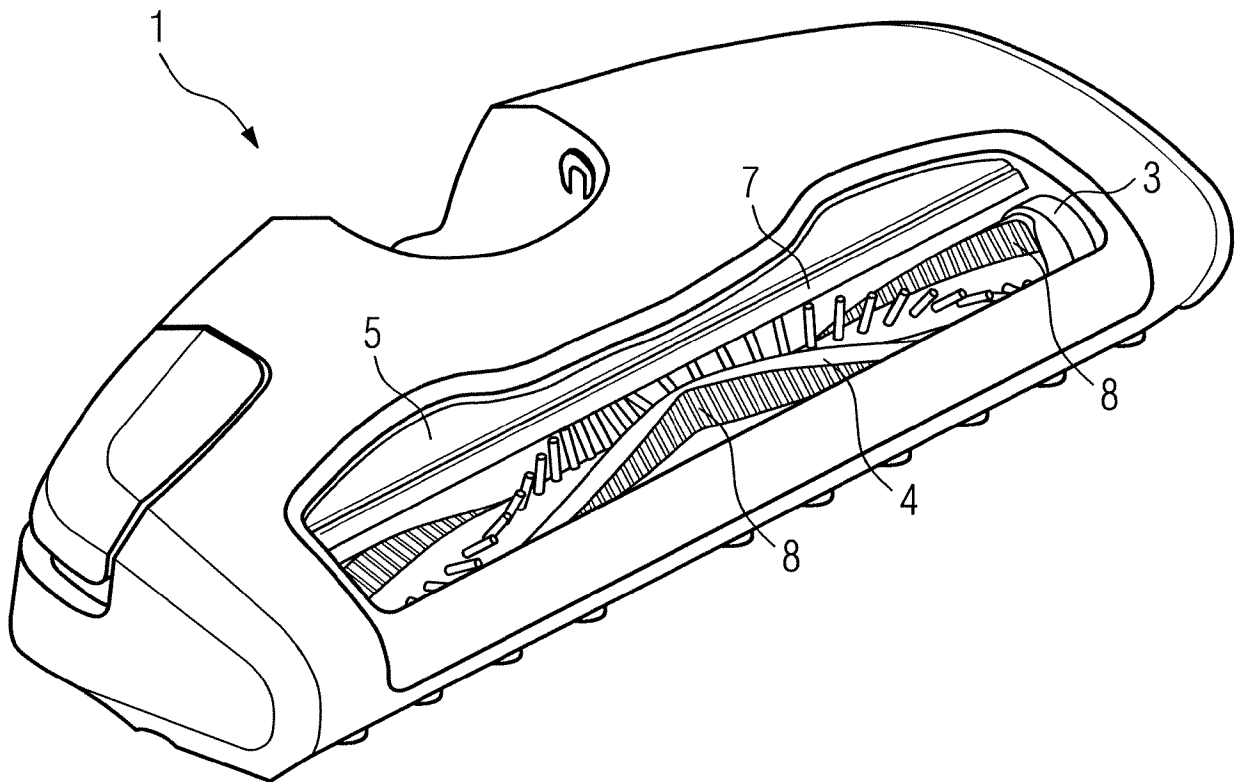

FIG 3

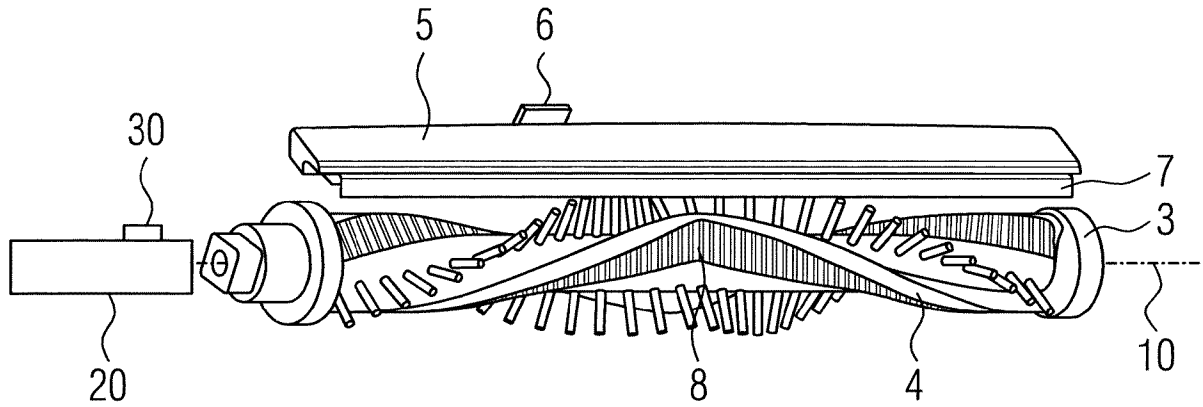

FIG 4

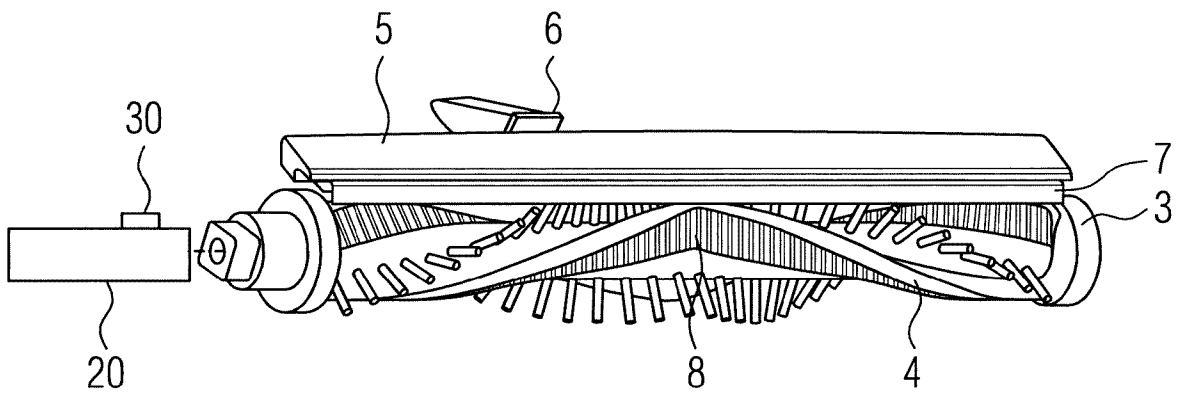

FIG 5

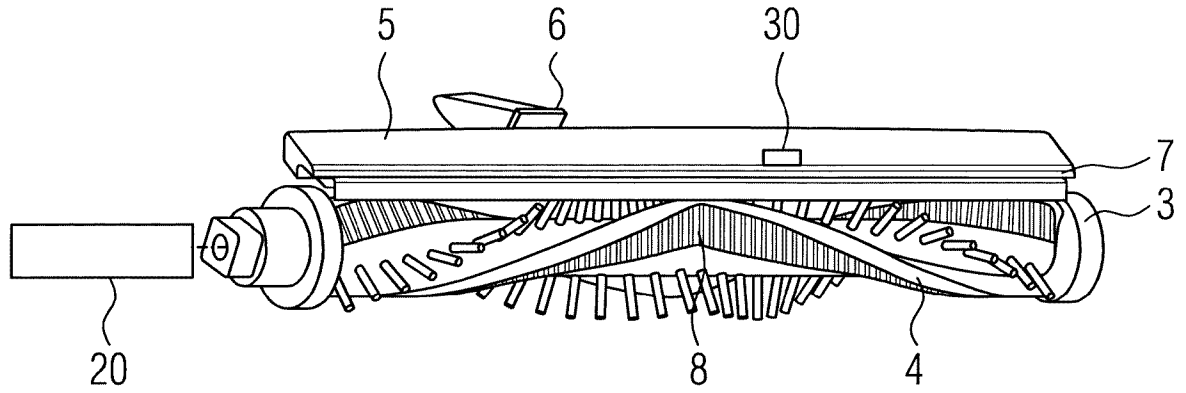
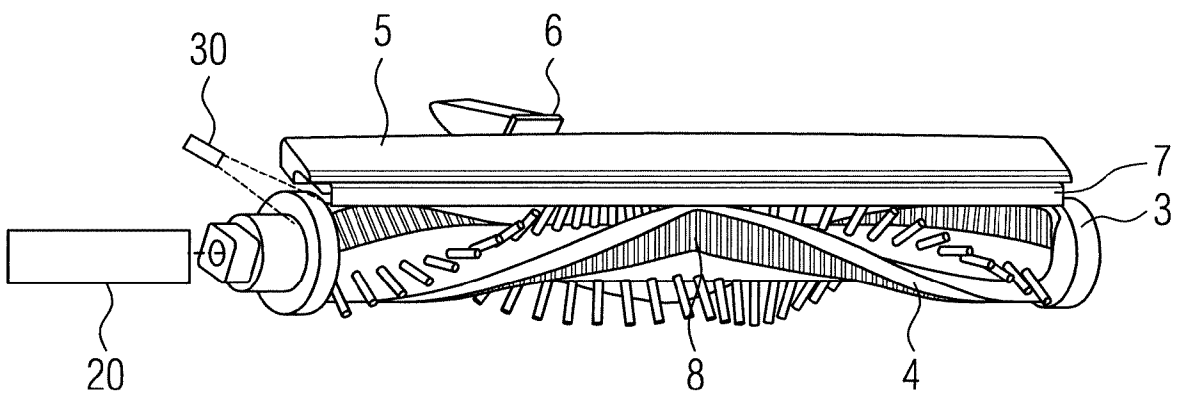

FIG 6



INTERNATIONAL SEARCH REPORT

International application No  
PCT/EP2013/058852

A. CLASSIFICATION OF SUBJECT MATTER  
INV. A47L9/04  
ADD.  
According to International Patent Classification (IPC) or to both national classification and IPC

B. FIELDS SEARCHED  
Minimum documentation searched (classification system followed by classification symbols)  
A47L

Documentation searched other than minimum documentation to the extent that such documents are included in the fields searched

Electronic data base consulted during the international search (name of data base and, where practicable, search terms used)  
EPO-Internal, WPI Data

C. DOCUMENTS CONSIDERED TO BE RELEVANT

Category*	Citation of document, with indication, where appropriate, of the relevant passages	Relevant to claim No.
Y	WO 2009/117383 A2 (ELECTROLUX HOME CARE PROD NA [US]) 24 September 2009 (2009-09-24) cited in the application paragraphs [0061] - [0062]	1,2,4,5, 8-14
A	-----	3,6,7,15
Y	EP 2 543 301 A1 (SAMSUNG ELECTRONICS CO LTD [KR]) 9 January 2013 (2013-01-09) paragraphs [0031] - [0067]	1,2,4,5, 8-14
A	-----	3,6,7,15
Y	US 2005/235452 A1 (CLOUD JOHN A III [US]) CLOUD III JOHN A [US] 27 October 2005 (2005-10-27) paragraphs [0026] - [0030]	1,2,5, 8-14
A	-----	3,4,6,7, 15
	----- -/--	

Further documents are listed in the continuation of Box C.

See patent family annex.

\* Special categories of cited documents :

- "A" document defining the general state of the art which is not considered to be of particular relevance
- "E" earlier application or patent but published on or after the international filing date
- "L" document which may throw doubts on priority claim(s) or which is cited to establish the publication date of another citation or other special reason (as specified)
- "O" document referring to an oral disclosure, use, exhibition or other means
- "P" document published prior to the international filing date but later than the priority date claimed

- "T" later document published after the international filing date or priority date and not in conflict with the application but cited to understand the principle or theory underlying the invention
- "X" document of particular relevance; the claimed invention cannot be considered novel or cannot be considered to involve an inventive step when the document is taken alone
- "Y" document of particular relevance; the claimed invention cannot be considered to involve an inventive step when the document is combined with one or more other such documents, such combination being obvious to a person skilled in the art
- "&" document member of the same patent family

Date of the actual completion of the international search

21 November 2013

Date of mailing of the international search report

04/12/2013

Name and mailing address of the ISA/

European Patent Office, P.B. 5818 Patentlaan 2  
NL - 2280 HV Rijswijk  
Tel. (+31-70) 340-2040,  
Fax: (+31-70) 340-3016

Authorized officer

Eckenschwiller, A

## INTERNATIONAL SEARCH REPORT

International application No  
PCT/EP2013/058852

C(Continuation). DOCUMENTS CONSIDERED TO BE RELEVANT		
Category*	Citation of document, with indication, where appropriate, of the relevant passages	Relevant to claim No.
Y	EP 1 656 874 A2 (MATSUSHITA ELECTRIC IND CO LTD [JP] PANASONIC CORP [JP]) 17 May 2006 (2006-05-17)	1,4,5, 8-14
A	paragraphs [0001] - [0010] paragraphs [0014] - [0030] -----	2,3,6,7, 15
Y	US 6 351 872 B1 (MCCORMICK MICHAEL J [US]) 5 March 2002 (2002-03-05)	1,5,8-14
A	column 6, lines 24-35 -----	2-4,6,7, 15
Y	EP 0 947 155 A2 (MATSUSHITA ELECTRIC IND CO LTD [JP]) 6 October 1999 (1999-10-06)	1,5,8-14
A	column 4, lines 5-14 paragraph [0012] -----	2-4,6,7, 15
A	JP 2003 014547 A (NEC TOKIN CORP; KIMURA MITSUTERU) 15 January 2003 (2003-01-15) abstract -----	6,7,15

## INTERNATIONAL SEARCH REPORT

Information on patent family members

International application No

PCT/EP2013/058852

Patent document cited in search report	Publication date	Patent family member(s)	Publication date		
WO 2009117383	A2	24-09-2009	CN 101984742 A	09-03-2011	
			EP 2273906 A2	19-01-2011	
			US 2009229075 A1	17-09-2009	
			US 2013192021 A1	01-08-2013	
			US 2013192022 A1	01-08-2013	
			US 2013192023 A1	01-08-2013	
			US 2013192024 A1	01-08-2013	
			WO 2009117383 A2	24-09-2009	
-----					
EP 2543301	A1	09-01-2013	EP 2543301 A1	09-01-2013	
			KR 20130005135 A	15-01-2013	
			US 2013007982 A1	10-01-2013	
-----					
US 2005235452	A1	27-10-2005	CA 2505332 A1	26-10-2005	
			US 2005235452 A1	27-10-2005	
-----					
EP 1656874	A2	17-05-2006	AT 427064 T	15-04-2009	
			CN 1771878 A	17-05-2006	
			EP 1656874 A2	17-05-2006	
			ES 2321731 T3	10-06-2009	
			JP 2006136512 A	01-06-2006	
			US 2006101605 A1	18-05-2006	
-----					
US 6351872	B1	05-03-2002	CA 2313667 A1	16-01-2001	
			US 6351872 B1	05-03-2002	
-----					
EP 0947155	A2	06-10-1999	AU 754001 B2	31-10-2002	
			AU 2356399 A	14-10-1999	
			CA 2268596 A1	03-10-1999	
			CA 2653510 A1	03-10-1999	
			CN 1235808 A	24-11-1999	
			CN 1507829 A	30-06-2004	
			DE 69928843 T2	17-08-2006	
			DE 69931971 T2	08-02-2007	
			DE 69936900 T2	15-05-2008	
			EP 0947155 A2	06-10-1999	
			EP 1293158 A1	19-03-2003	
			EP 1297773 A1	02-04-2003	
			ES 2254586 T3	16-06-2006	
			ES 2265471 T3	16-02-2007	
			ES 2292214 T3	01-03-2008	
			JP H11313786 A	16-11-1999	
			KR 100384980 B1	02-06-2003	
			US 6323570 B1	27-11-2001	
			US 6400048 B1	04-06-2002	
			US 2002079761 A1	27-06-2002	
-----					
JP 2003014547	A	15-01-2003	NONE		
-----					