



US011453235B2

(12) **United States Patent**
Backman

(10) **Patent No.:** **US 11,453,235 B2**
(45) **Date of Patent:** **Sep. 27, 2022**

(54) **CHALK LINE MARKING DEVICE**

(71) Applicant: **Joshua Backman**, Samoa, CA (US)

(72) Inventor: **Joshua Backman**, Samoa, CA (US)

(*) Notice: Subject to any disclaimer, the term of this patent is extended or adjusted under 35 U.S.C. 154(b) by 111 days.

4,819,337 A * 4/1989 Noyes B44D 3/38
33/414
6,141,880 A * 11/2000 Vircks H01Q 11/14
33/1 G
6,345,448 B1 * 2/2002 Chontos G01C 15/10
33/339
9,174,486 B2 * 11/2015 Planavsky B44D 3/38
10,583,687 B2 * 3/2020 Fox B44D 3/38
10,926,576 B2 * 2/2021 Franco B44D 3/38

* cited by examiner

(21) Appl. No.: **17/123,301**

(22) Filed: **Dec. 16, 2020**

(65) **Prior Publication Data**

US 2022/0185005 A1 Jun. 16, 2022

(51) **Int. Cl.**

B44D 3/38 (2006.01)

G01C 9/28 (2006.01)

(52) **U.S. Cl.**

CPC **B44D 3/38** (2013.01); **G01C 9/28** (2013.01)

(58) **Field of Classification Search**

CPC B44D 3/38

USPC 33/413, 414

See application file for complete search history.

(56) **References Cited**

U.S. PATENT DOCUMENTS

1,505,286 A * 8/1924 Peterson B44D 3/38
33/414
4,660,291 A * 4/1987 Dehn B44D 3/38
33/414

Primary Examiner — George B Bennett

(74) *Attorney, Agent, or Firm* — The Iwashko Law Firm, PLLC; Lev Ivan Gabriel Iwashko

(57) **ABSTRACT**

A chalk line marking device, including a main body, including a first section disposed on at least a portion of a first end of the main body, and a second section disposed on at least a portion of a second end of the main body, a handle disposed between the first section and the second section to facilitate gripping thereof, and a chalk string disposed within at least a portion of the main body and the handle, and around a first tip of the main body and a second tip of the main body to move the first section and the second section from bent in a first position to at least partially extended in a second position, such that the chalk string creates a chalk line in response to movement of the first section and the second section.

9 Claims, 3 Drawing Sheets

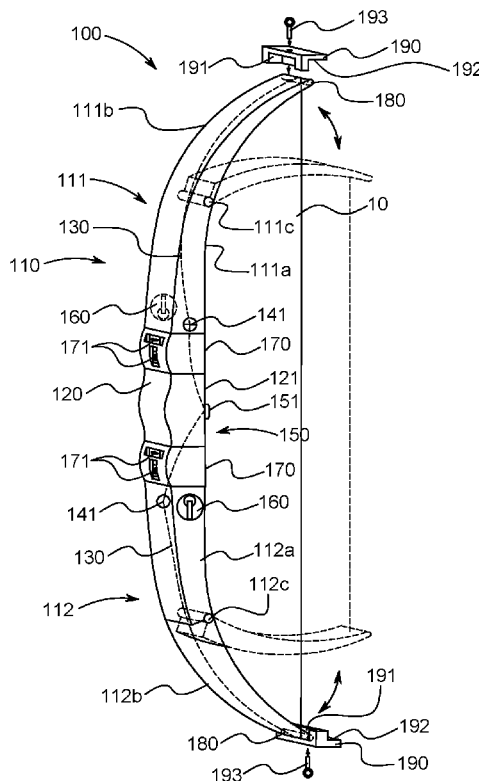

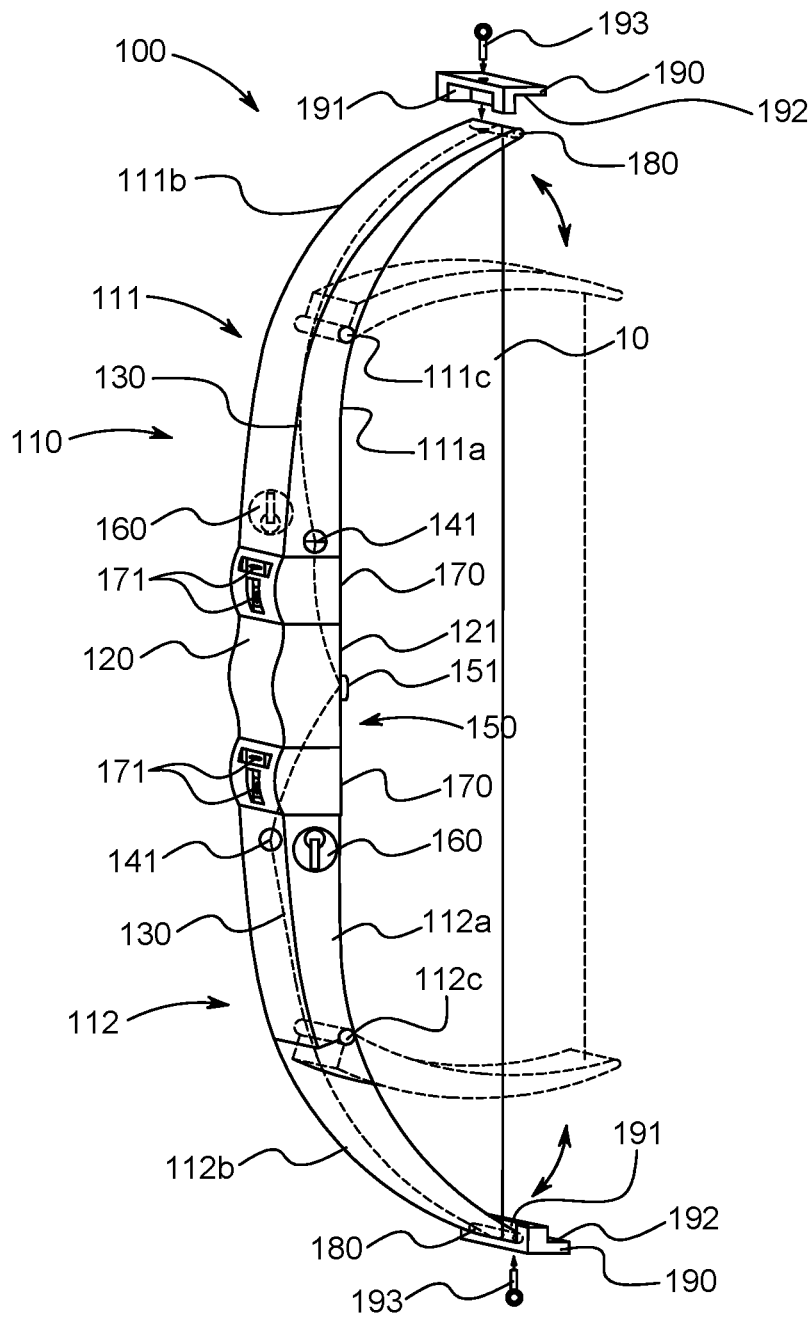

FIG. 1

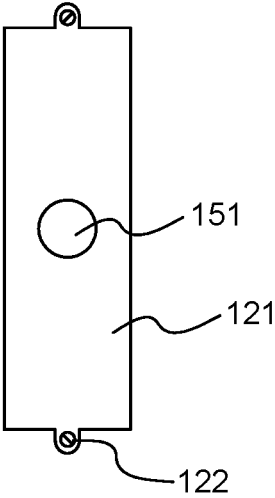

FIG. 2

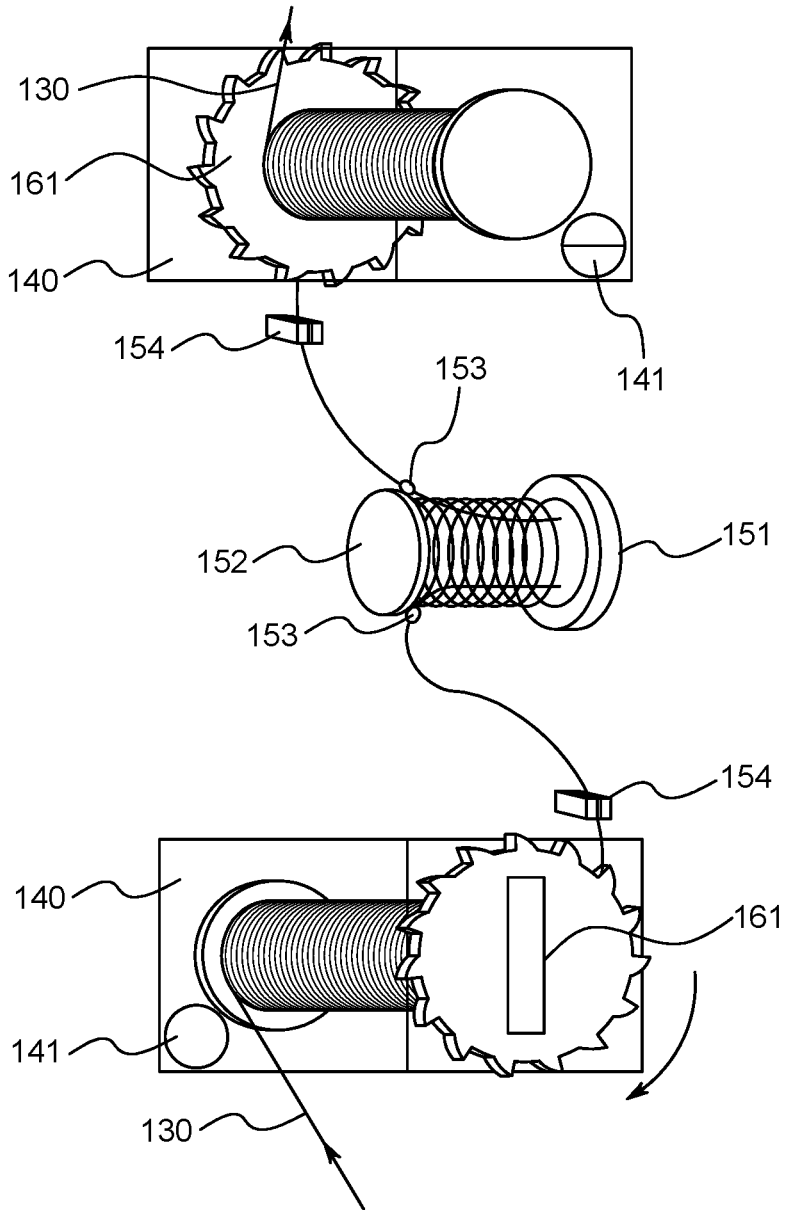

FIG. 3

1

CHALK LINE MARKING DEVICE

BACKGROUND

1. Field

The present general inventive concept relates generally to a marking device, and particularly, to a chalk line marking device.

2. Description of the Related Art

In certain areas of work, marking a chalk line can be an incredibly labor intensive and grueling process. Moreover, this type of manual labor requires multiple people to complete and other pieces of heavy equipment like a ladder to mark high points on a wall and/or a ceiling. Furthermore, marking the chalk line around particular edges entails extreme stability and might require repetition. Unsurprisingly, the task often leads to frustration among professionals.

The necessity of having multiple people enhances the probability of human error and can lead to incorrect construction of a building and/or installation of hardware.

Therefore, there is a need for chalk line marking device that draws the chalk line without requiring more than one person to mark a point.

SUMMARY

The present general inventive concept provides a chalk line marking device.

Additional features and utilities of the present general inventive concept will be set forth in part in the description which follows and, in part, will be obvious from the description, or may be learned by practice of the general inventive concept.

The foregoing and/or other features and utilities of the present general inventive concept may be achieved by providing a chalk line marking device, including a main body, including a first section disposed on at least a portion of a first end of the main body, and a second section disposed on at least a portion of a second end of the main body, a handle disposed between the first section and the second section to facilitate gripping thereof, and a chalk string disposed within at least a portion of the main body and the handle, and around a first tip of the main body and a second tip of the main body to move the first section and the second section from bent in a first position to at least partially extended in a second position, such that the chalk string creates a chalk line in response to movement of the first section and the second section.

The first section may include a first proximal section, a first distal section pivotally disposed on at least a portion of the first proximal section to move from the first position to at least partially toward the second position, and move from the second position to the first position, and a first splined pivot to connect the first proximal section to the first distal section.

The first splined pivot may lock the first distal section at predetermined positions or unlocks to facilitate movement of the first distal section.

The second section may include a second proximal section, a second distal section pivotally disposed on at least a portion of the second proximal section to move from the first position to at least partially toward the second position, and

2

move from the second position to the first position, and a second splined pivot to connect the second proximal section to the second distal section.

The second splined pivot may lock the second distal section at predetermined positions or unlocks to facilitate movement of the second distal section.

The chalk line marking device may further include a plurality of chalk boxes disposed within at least a portion of the first section and at least a portion of the second section to store the chalk therein, such that movement of the chalk string therethrough covers the chalk string in the chalk.

The chalk line marking device may further include a spring tensioning assembly disposed within at least a portion of the main body and the handle, the spring tensioning assembly including a release trigger to move the first section and the second section in response to depressing the release trigger, and a spring connector connected to the release trigger and the chalk string to spring bias the chalk string toward the interior of the handle.

The chalk line marking device may further include a plurality of bubble sections disposed on at least a portion of a first end of the handle and a second end of the handle, each of the plurality of bubble sections including a plurality of bubble levels to indicate a level of a first plane and a second plane, such that each of the plurality of bubble levels is perpendicular with respect to each other.

The chalk line marking device may further include a plurality of wood connectors to removably connect to at least a portion of the first section and at least a portion of the second section to facilitate marking the chalk line around a wooden surface.

BRIEF DESCRIPTION OF THE DRAWINGS

These and/or other features and utilities of the present generally inventive concept will become apparent and more readily appreciated from the following description of the embodiments, taken in conjunction with the accompanying drawings of which:

FIG. 1 illustrates a side perspective view of a chalk line marking device, according to an exemplary embodiment of the present general inventive concept;

FIG. 2 illustrates a zoomed in view of a handle cover, according to an exemplary embodiment of the present general inventive concept; and

FIG. 3 illustrates a zoomed in view of a chalk string disposed within a plurality of chalk boxes and on a spring tensioning assembly, according to an exemplary embodiment of the present general inventive concept.

DETAILED DESCRIPTION

Various example embodiments (a.k.a., exemplary embodiments) will now be described more fully with reference to the accompanying drawings in which some example embodiments are illustrated. In the figures, the thicknesses of lines, layers and/or regions may be exaggerated for clarity.

Accordingly, while example embodiments are capable of various modifications and alternative forms, embodiments thereof are shown by way of example in the figures and will herein be described in detail. It should be understood, however, that there is no intent to limit example embodiments to the particular forms disclosed, but on the contrary, example embodiments are to cover all modifications, equivalents, and alternatives falling within the scope of the

disclosure. Like numbers refer to like/similar elements throughout the detailed description.

It is understood that when an element is referred to as being “connected” or “coupled” to another element, it can be directly connected or coupled to the other element or intervening elements may be present. In contrast, when an element is referred to as being “directly connected” or “directly coupled” to another element, there are no intervening elements present. Other words used to describe the relationship between elements should be interpreted in a like fashion (e.g., “between” versus “directly between,” “adjacent” versus “directly adjacent,” etc.).

The terminology used herein is for the purpose of describing particular embodiments only and is not intended to be limiting of example embodiments. As used herein, the singular forms “a,” “an” and “the” are intended to include the plural forms as well, unless the context clearly indicates otherwise. It will be further understood that the terms “comprises,” “comprising,” “includes” and/or “including,” when used herein, specify the presence of stated features, integers, steps, operations, elements and/or components, but do not preclude the presence or addition of one or more other features, integers, steps, operations, elements, components and/or groups thereof.

Unless otherwise defined, all terms (including technical and scientific terms) used herein have the same meaning as commonly understood by one of ordinary skill in the art to which example embodiments belong. It will be further understood that terms, e.g., those defined in commonly used dictionaries, should be interpreted as having a meaning that is consistent with their meaning in the context of the relevant art. However, should the present disclosure give a specific meaning to a term deviating from a meaning commonly understood by one of ordinary skill, this meaning is to be taken into account in the specific context this definition is given herein.

LIST OF COMPONENTS

Chalk Line Marking Device **100**
 Main Body **110**
 First Section **111**
 First Proximal Section **111a**
 First Distal Section **111b**
 First Splined Pivot **111c**
 Second Section **112**
 Second Proximal Section **112a**
 Second Distal Section **112b**
 Second Splined Pivot **112c**
 Handle **120**
 Handle Cover **121**
 Cover Fastener **122**
 Chalk String **130**
 Chalk Boxes **140**
 Chalk Box Cover **141**
 Spring Tensioning Assembly **150**
 Release Trigger **151**
 Spring Connector **152**
 Spring Stops **153**
 Chalk String Holder **154**
 Cranks **160**
 Ratchet **161**
 Level Sections **170**
 Bubble Levels **171**
 Rollers **180**
 Wood Connectors **190**
 Body Receiving Groove **191**

Surface Receiving Groove **192**
 Fastener **193**

FIG. 1 illustrates a side perspective view of a chalk line marking device **100**, according to an exemplary embodiment of the present general inventive concept.

FIG. 2 illustrates a zoomed in view of a handle cover **121**, according to an exemplary embodiment of the present general inventive concept.

FIG. 3 illustrates a zoomed in view of a chalk string **130** disposed within a plurality of chalk boxes **140** and on a spring tensioning assembly **150**, according to an exemplary embodiment of the present general inventive concept.

The chalk line marking device **100** may be constructed from at least one of plastic, metal, wood, glass, and rubber, etc., but is not limited thereto.

The chalk line marking device **100** may include a main body **110**, a handle **120**, a chalk string **130**, a plurality of chalk boxes **140**, a spring tensioning assembly **150**, a plurality of cranks **160**, a plurality of level sections **170**, a plurality of rollers **180**, and a plurality of wood connectors **190** but is not limited thereto.

Referring to FIG. 1, the main body **110** is illustrated to have a bow shape. However, the main body may be rectangular, circular, conical, triangular, pentagonal, hexagonal, heptagonal, octagonal, or any other shape known to one of ordinary skill in the art, but is not limited thereto.

The main body **110** may include a first section **111** and a second section **112**, but is not limited thereto.

The first section **111** may be disposed on at least a portion of a first end of the main body **110**. The second section **112** may be disposed on at least a portion of a second end of the main body **110** opposite with respect to the first end of the main body **110**.

The first section **111** may include a first proximal section **111a**, a first distal section **111b**, and a first splined pivot **111c**, but is not limited thereto.

Referring again to FIG. 1, the first distal section **111b** may be pivotally disposed on at least a portion of the first proximal section **111a** via the first splined pivot **111c**. In other words, the first splined pivot **111c** may connect the first proximal section **111a** to the first distal section **111b**. Moreover, the first distal section **111b** may move (i.e. pivot) from a first position (i.e. a bent position illustrated in broken lines) to at least partially toward a second position (i.e. extended position). Furthermore, a first end of the first distal section **111b** may be in full contact with an end of the first proximal section **111a** during full extension. In other words, the first distal section **111b** may be flush with the first proximal section **111a** during full extension.

Additionally, the first splined pivot **111c** may stop moving at predetermined intervals. In other words, the first splined pivot **111c** may lock the first distal section **111b** at predetermined positions and/or unlock to facilitate movement of the first distal section **111b**.

The second section **112** may include a second proximal section **112a**, a second distal section **112b**, and a second splined pivot **112c**, but is not limited thereto.

Referring again to FIG. 1, the second distal section **112b** may be pivotally disposed on at least a portion of the second proximal section **112a** via the second splined pivot **112c**. In other words, the second splined pivot **112c** may connect the second proximal section **112a** to the second distal section **112b**. Moreover, the second distal section **112b** may move (i.e. pivot) from a first position (i.e. a bent position illustrated in broken lines) to at least partially toward a second position (i.e. extended position). Furthermore, a first end of the second distal section **112b** may be in full contact with an

end of the second proximal section **112a** during full extension. In other words, the second distal section **112b** may be flush with the second proximal section **112a** during full extension.

Additionally, the second splined pivot **112c** may stop moving at predetermined intervals. In other words, the second splined pivot **112c** may lock the second distal section **112b** at predetermined positions and/or unlock to facilitate movement of the second distal section **112b**.

The handle **120** may include a handle cover **121** and at least one cover fastener **122** (e.g., a screw, a nail, a nut, a washer, a bolt, an adhesive, a magnet, and/or any combination thereof), but is not limited thereto.

The handle **120** may be disposed between the first section **111** and the second section **112**. In other words, the handle **120** may connect the first section **111** to the second section **112** and/or vice versa. The handle **120** may facilitate gripping thereof.

The handle cover **121** may be removably connected to the handle **120** using the at least one cover fastener **122**. Accordingly, removing the handle cover **121** may facilitate access to an interior of the handle **120** and/or the main body **110**.

The chalk string **130** may be disposed within at least a portion of the main body **110** and/or the handle **120**. Moreover, the chalk string **130** may extend from the first distal section **111b** to the second distal section **112b** within the main body **110** and/or the handle **120**.

Each of the plurality of chalk boxes **140** may include a chalk box cover **141**, but is not limited thereto.

Referring to FIGS. **1** and **3**, each of the plurality of chalk boxes **140** may be disposed within at least a portion of the first proximal section **111a** and/or the second proximal section **112a**. Additionally, each of the plurality of chalk boxes **140** may store chalk therein. Also, the chalk string **130** may move through the plurality of chalk boxes **140**, such that the chalk string **130** may be covered in the chalk.

The chalk box cover **141** may be removably connected to at least a portion of each of the plurality of chalk boxes **140** to cover at least a portion of each of the plurality of chalk boxes **140**. Therefore, the chalk box cover **141** may be removed to allow chalk to be inserted within the plurality of chalk boxes **140**.

Also, the chalk string **130** may be accessed after removing the handle cover **121**, such that the chalk string **130** may be replaced.

The spring tensioning assembly **150** may include a release trigger **151**, a spring connector **152**, a plurality of spring stops **153**, and at least one chalk string holder **154**, but is not limited thereto.

The spring tensioning assembly **150** may be disposed within at least a portion of the main body **110** and/or the handle **120**. More specifically, the release trigger **151** may be disposed on and/or within at least as portion of the handle cover **121**. The spring connector **152** may be connected to the release trigger **151** and/or the chalk string **130**.

Referring to FIG. **3**, the chalk string **130** may wrap around the spring connector **152**. Also, the spring connector **152** may be spring biased to move (i.e. rotate) the chalk string **130** thereto. In other words, the spring connector **152** may receive the chalk string **130** thereon and spring bias the chalk string **130** toward the interior of the handle **120**. Furthermore, each of the plurality of spring stops **153** may prevent the spring connector **152** from moving.

The at least one chalk string holder **154** may facilitate movement of the chalk string **130** within the main body **110** and/or the handle **120**. In particular, the at least one chalk

string holder **154** may guide the chalk string **130** during movement within the main body **110** and/or the handle **120**, such that the chalk string **130** may not be loose.

In operation, the plurality of spring stops **153** may release the spring connector **152** in response to depressing the release trigger **151**, such that the spring connector **152** may rotate to move the chalk string **130** toward the interior of the handle **120**, such that the first distal section **111b** and/or the second distal section **112b** may move at least partially toward the second position. In other words, the first distal section **111b** and/or the second distal section **112b** may move at least partially toward the second position in response to depressing the release trigger **151** in a snapping motion. Also, releasing the release trigger **151** may allow the first distal section **111b** and/or the second distal section **112b** to move to the predetermined positions based on the first splined pivot **111c** and/or the second splined pivot **112c**.

Each of the plurality of cranks **160** may include a ratchet **161**, but is not limited thereto.

The plurality of cranks **160** may be disposed on at least a portion of the first proximal section **111a** and/or the second proximal section **112a**. Moreover, each of the plurality of cranks **160** may be connected to the ratchet **161**, such that the ratchet **161** rotates in response to rotation of the plurality of cranks **160**. The plurality of cranks **160** may be rotated in a first direction (i.e. clockwise) or a second direction (i.e. counterclockwise) to move the first distal section **111b** and/or the second distal section **112b** toward the first position. As such, the plurality of cranks **160** may reset the first distal section **111b** and/or the second distal section **112b** to the first position.

Each of the plurality of level sections **170** may include a plurality of bubble levels **171**, but is not limited thereto.

The plurality of bubble sections **170** may be disposed on at least a portion of a first end of the handle **120** and/or a second end of the handle **120**. Additionally, the plurality of bubble levels **171** may provide an indication of a level on a first plane and/or a second plane different from the first plane. Also, each of the plurality of bubble levels **171** may be perpendicular with respect to the each other. As such, the plurality of bubble levels **171** may provide level readings on two planar surfaces, such as a ground surface and/or a wall perpendicularly disposed with respect to the ground surface. Accordingly, the plurality of bubble levels **171** may facilitate measuring angles and positions on the planar surface.

The plurality of rollers **180** may be disposed on at least a portion of a second end of the first distal section **111b** (i.e. a first tip of the main body **110**) and/or a second end of the second distal section **112b** (i.e. a second tip of the main body **110**). The chalk string **130** may be disposed around each of the plurality of rollers **180**, such that the chalk string **130** may loop around the plurality of rollers **180** and back within the main body **110**. As such, the chalk string **130** moving along the plurality of rollers **180** may mark a chalk line on the planar surface in response to depressing the release trigger **151**.

Each of the plurality of wood connectors **190** may include a body receiving groove **191**, a surface receiving groove **192**, and a fastener **193** (e.g., a screw, a nail, a nut, a washer, a bolt, an adhesive, a magnet, and/or any combination thereof), but is not limited thereto.

The plurality of wood connectors **190** may be removably connected to at least a portion of the second end of the first distal section **111b** and/or the second end of the second distal section **112b**. Specifically, the body receiving groove **191**

may receive the second end of the first distal section **111b** and/or the second end of the second distal section **112b**.

The surface receiving groove **192** may receive a wooden surface (e.g., a board of plywood) therein. Finally, the fastener **193** may be removably inserted through the body receiving groove **191** to connect the plurality of wood connectors **190** to the second end of the first distal section **111b** and/or the second end of the second distal section **112b**. As such, the plurality of wood connectors **190** may facilitate marking the chalk line around the wooden surface, such as for a rip cut and/or a stud marking.

Therefore, the chalk line marking device **100** may facilitate creating a line with chalk without requiring another person. Also, the chalk line marking device **100** may create lines at a desired angle and/or position due to the plurality of bubble levels **171**.

The present general inventive concept may include a chalk line marking device **100**, including a main body **110**, including a first section **111** disposed on at least a portion of a first end of the main body **110**, and a second section **112** disposed on at least a portion of a second end of the main body **110**, a handle **120** disposed between the first section **111** and the second section **112** to facilitate gripping thereof, and a chalk string **130** disposed within at least a portion of the main body **110** and the handle **120**, and around a first tip of the main body **110** and a second tip of the main body **110** to move the first section **111** and the second section **112** from bent in a first position to at least partially extended in a second position, such that the chalk string **130** creates a chalk line in response to movement of the first section **111** and the second section **112**.

The first section **111** may include a first proximal section **111a**, a first distal section **111b** pivotally disposed on at least a portion of the first proximal section **111a** to move from the first position to at least partially toward the second position, and move from the second position to the first position, and a first splined pivot **111c** to connect the first proximal section **111a** to the first distal section **111b**.

The first splined pivot **111c** may lock the first distal section **111b** at predetermined positions or unlocks to facilitate movement of the first distal section **111b**.

The second section **112** may include a second proximal section **112a**, a second distal section **112b** pivotally disposed on at least a portion of the second proximal section **112a** to move from the first position to at least partially toward the second position, and move from the second position to the first position, and a second splined pivot **112c** to connect the second proximal section **112a** to the second distal section **112b**.

The second splined pivot **112c** may lock the second distal section **112b** at predetermined positions or unlocks to facilitate movement of the second distal section **112b**.

The chalk line marking device **100** may further include a plurality of chalk boxes **140** disposed within at least a portion of the first section **111** and at least a portion of the second section **112** to store the chalk therein, such that movement of the chalk string **130** therethrough covers the chalk string **130** in the chalk.

The chalk line marking device **100** may further include a spring tensioning assembly **150** disposed within at least a portion of the main body **110** and the handle **120**, the spring tensioning assembly **150** including a release trigger **151** to move the first section **111** and the second section **112** in response to depressing the release trigger **151**, and a spring connector **152** connected to the release trigger **151** and the chalk string **130** to spring bias the chalk string **130** toward the interior of the handle **120**.

The chalk line marking device **100** may further include a plurality of bubble sections **170** disposed on at least a portion of a first end of the handle **120** and a second end of the handle **120**, each of the plurality of bubble sections **170** including a plurality of bubble levels **171** to indicate a level of a first plane and a second plane, such that each of the plurality of bubble levels **171** is perpendicular with respect to each other.

The chalk line marking device **100** may further include a plurality of wood connectors **190** to removably connect to at least a portion of the first section **111** and at least a portion of the second section **112** to facilitate marking the chalk line around a wooden surface.

Although a few embodiments of the present general inventive concept have been shown and described, it will be appreciated by those skilled in the art that changes may be made in these embodiments without departing from the principles and spirit of the general inventive concept, the scope of which is defined in the appended claims and their equivalents.

The invention claimed is:

1. A chalk line marking device, comprising:

a main body, comprising:

a first section disposed on at least a portion of a first end of the main body, and
a second section disposed on at least a portion of a second end of the main body;

a handle disposed between the first section and the second section to facilitate gripping thereof; and

a chalk string disposed within at least a portion of the main body and the handle, and around a first tip of the main body and a second tip of the main body to move the first section and the second section from bent in a first position to at least partially extended in a second position, such that the chalk string creates a chalk line in response to movement of the first section and the second section.

2. The chalk line marking device of claim 1, wherein the first section comprises:

a first proximal section;

a first distal section pivotally disposed on at least a portion of the first proximal section to move from the first position to at least partially toward the second position, and move from the second position to the first position; and

a first splined pivot to connect the first proximal section to the first distal section.

3. The chalk line marking device of claim 2, wherein the first splined pivot locks the first distal section at predetermined positions or unlocks to facilitate movement of the first distal section.

4. The chalk line marking device of claim 1, wherein the second section comprises:

a second proximal section;

a second distal section pivotally disposed on at least a portion of the second proximal section to move from the first position to at least partially toward the second position, and move from the second position to the first position; and

a second splined pivot to connect the second proximal section to the second distal section.

5. The chalk line marking device of claim 4, wherein the second splined pivot locks the second distal section at predetermined positions or unlocks to facilitate movement of the second distal section.

6. The chalk line marking device of claim 1, further comprising:

a plurality of chalk boxes disposed within at least a portion of the first section and at least a portion of the second section to store the chalk therein, such that movement of the chalk string therethrough covers the chalk string in the chalk. 5

7. The chalk line marking device of claim 1, further comprising:

a spring tensioning assembly disposed within at least a portion of the main body and the handle, the spring tensioning assembly comprising: 10

a release trigger to move the first section and the second section in response to depressing the release trigger, and

a spring connector connected to the release trigger and the chalk string to spring bias the chalk string toward the interior of the handle. 15

8. The chalk line marking device of claim 1, further comprising:

a plurality of bubble sections disposed on at least a portion of a first end of the handle and a second end of the handle, each of the plurality of bubble sections comprising: 20

a plurality of bubble levels to indicate a level of a first plane and a second plane, such that each of the plurality of bubble levels is perpendicular with respect to each other. 25

9. The chalk line marking device of claim 1, further comprising:

a plurality of wood connectors to removably connect to at least a portion of the first section and at least a portion of the second section to facilitate marking the chalk line around a wooden surface. 30

* * * * *