



US00D899342S

(12) **United States Design Patent**  
**O'Neill**

(10) **Patent No.:** **US D899,342 S**

(45) **Date of Patent:** **\*\* Oct. 20, 2020**

(54) **WHEEL**

(71) Applicant: **Jaguar Land Rover Limited**, Whitley,  
Coventry (GB)

(72) Inventor: **Michael O'Neill**, Coventry (GB)

(73) Assignee: **Jaguar Land Rover Limited**, Whitley  
Coventry (GB)

(\*\*) Term: **15 Years**

(21) Appl. No.: **29/716,434**

(22) Filed: **Dec. 10, 2019**

**Related U.S. Application Data**

(62) Division of application No. 29/629,399, filed on Dec.  
13, 2017, now Pat. No. Des. 872,675.

(30) **Foreign Application Priority Data**

Jun. 15, 2017 (EM) ..... 004048882

(51) **LOC (12) Cl.** ..... **12-16**

(52) **U.S. Cl.**  
USPC ..... **D12/211**

(58) **Field of Classification Search**

USPC ..... D12/204–213; D21/563  
CPC .... B60B 7/00; B60B 7/02; B60B 7/04; B60B  
7/01; B60B 7/06; B60B 3/02; B60B 3/04;  
B60B 3/06; B60B 3/10; B60B 1/00;  
B60B 1/08; B60B 1/10; B60B 1/12  
See application file for complete search history.

(56) **References Cited**

**U.S. PATENT DOCUMENTS**

D670,632 S \* 11/2012 Schweizer ..... D12/211  
D718,206 S \* 11/2014 Song ..... D12/211  
D744,402 S \* 12/2015 Watkin ..... D12/211  
D749,029 S \* 2/2016 Wheel ..... D12/211

D761,182 S \* 7/2016 Valencia Pollex ..... D12/211  
D767,466 S \* 9/2016 Juergens ..... D12/211  
D784,898 S \* 4/2017 Setter ..... D12/211  
D787,409 S \* 5/2017 Smith ..... D12/211  
D794,529 S \* 8/2017 Valencia Pollex ..... D12/211  
D795,152 S \* 8/2017 Peat ..... D12/211  
D801,902 S \* 11/2017 Pena ..... D12/211  
D801,905 S \* 11/2017 Rueckheim ..... D12/211  
D826,824 S \* 8/2018 Platto ..... D12/209

(Continued)

*Primary Examiner* — Stacia A Cadmus

(74) *Attorney, Agent, or Firm* — Wood Herron & Evans  
LLP

(57) **CLAIM**

The ornamental design for a wheel, as shown and described.

**DESCRIPTION**

FIG. 1 is a front left perspective view of a wheel according  
to the present invention.

FIG. 2 is a front right perspective view of the wheel shown  
in FIG. 1.

FIG. 3 is a front view thereof.

FIG. 4 is a left side view thereof, the right side being a mirror  
image thereof.

FIG. 5 is a rear view thereof.

FIG. 6 is a rear right perspective view thereof.

FIG. 7 is a rear left perspective view thereof.

FIG. 8 is a front left perspective view of a wheel according  
to a second embodiment of the present invention.

FIG. 9 is a front right perspective view of the wheel shown  
in FIG. 8.

FIG. 10 is a front view thereof.

FIG. 11 is a left side view thereof, the right side being a  
mirror image thereof.

FIG. 12 is a rear view thereof.

FIG. 13 is a rear right perspective view thereof; and,

FIG. 14 is a rear left perspective view thereof.

**1 Claim, 10 Drawing Sheets**

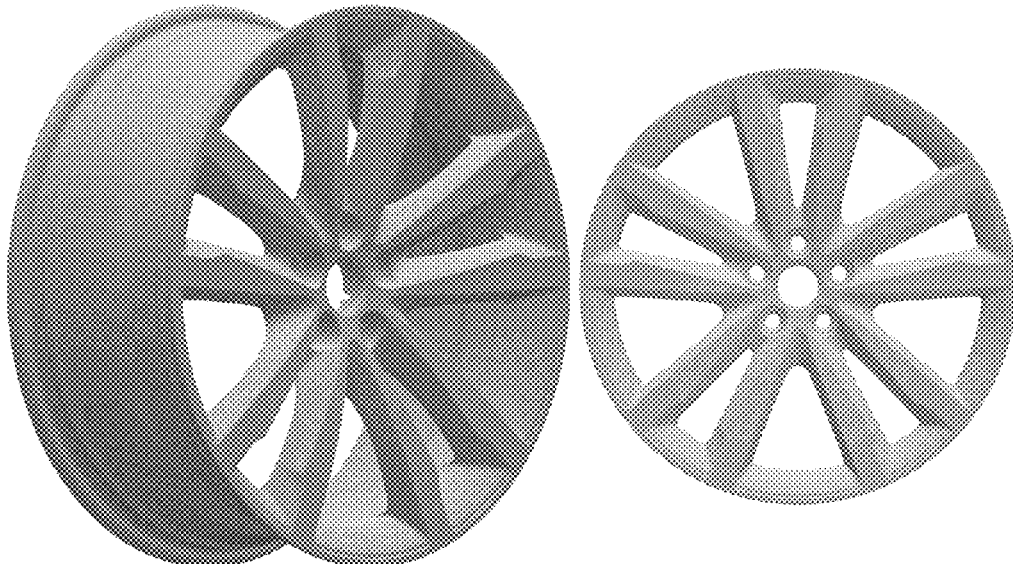

(56)

**References Cited**

U.S. PATENT DOCUMENTS

D847,072	S	*	4/2019	Badstuebner	.....	D12/209
D849,656	S	*	5/2019	Peat	.....	D12/211
D857,597	S	*	8/2019	Muto	.....	D12/211
D858,413	S	*	9/2019	Woodhouse	.....	D12/211
D858,416	S	*	9/2019	Dewitt	.....	D12/211
D872,675	S	*	1/2020	O'Neill	.....	D12/211
D876,308	S	*	2/2020	O'Neill	.....	D12/209
D883,888	S	*	5/2020	Daniel	.....	D12/209

\* cited by examiner



FIG. 1



FIG. 2

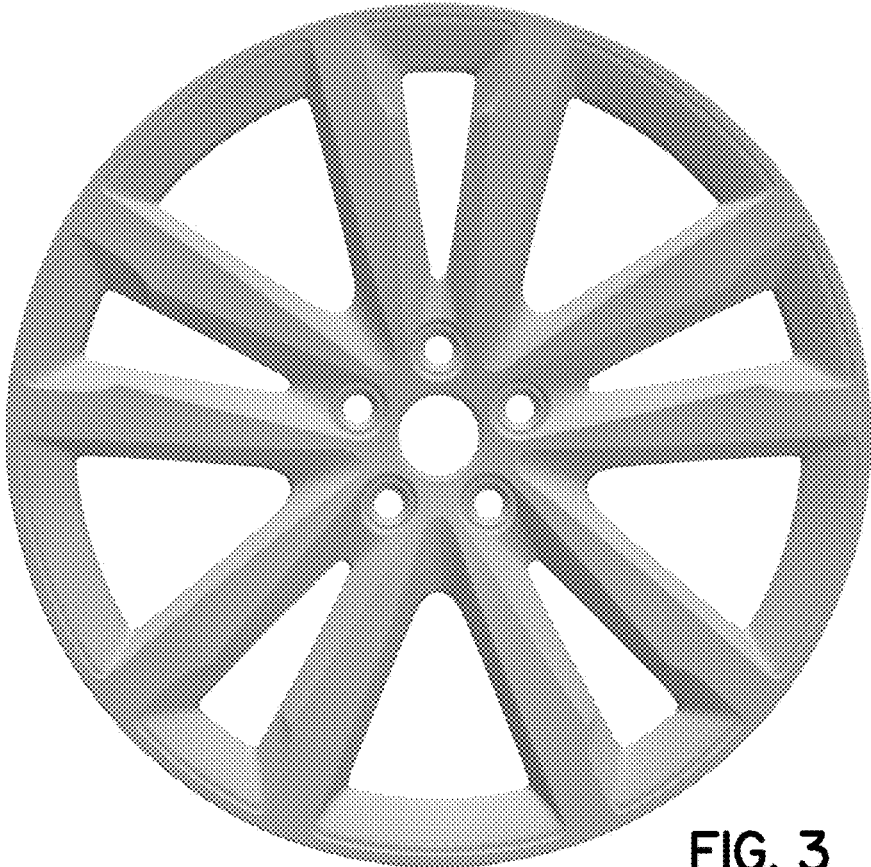

FIG. 3

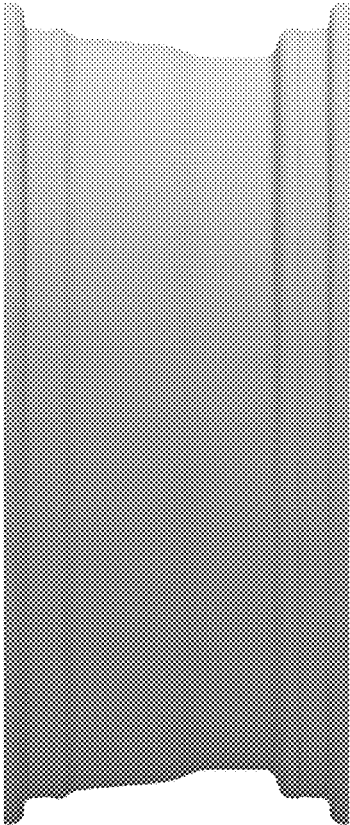

FIG. 4

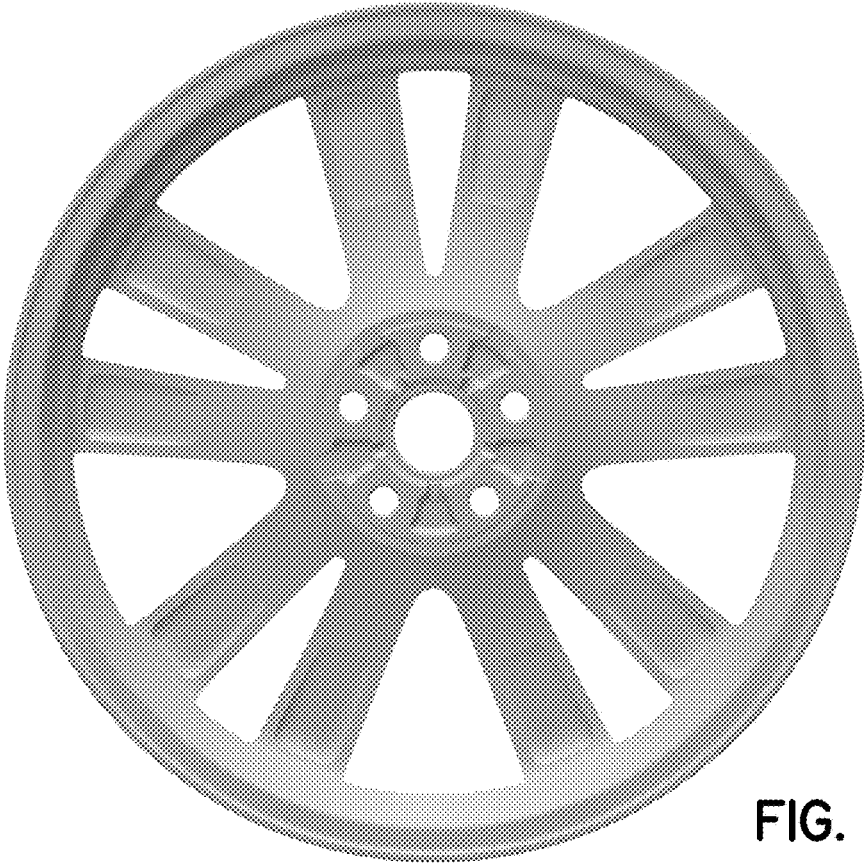

FIG. 5



FIG. 6



FIG. 7



FIG. 8



FIG. 9

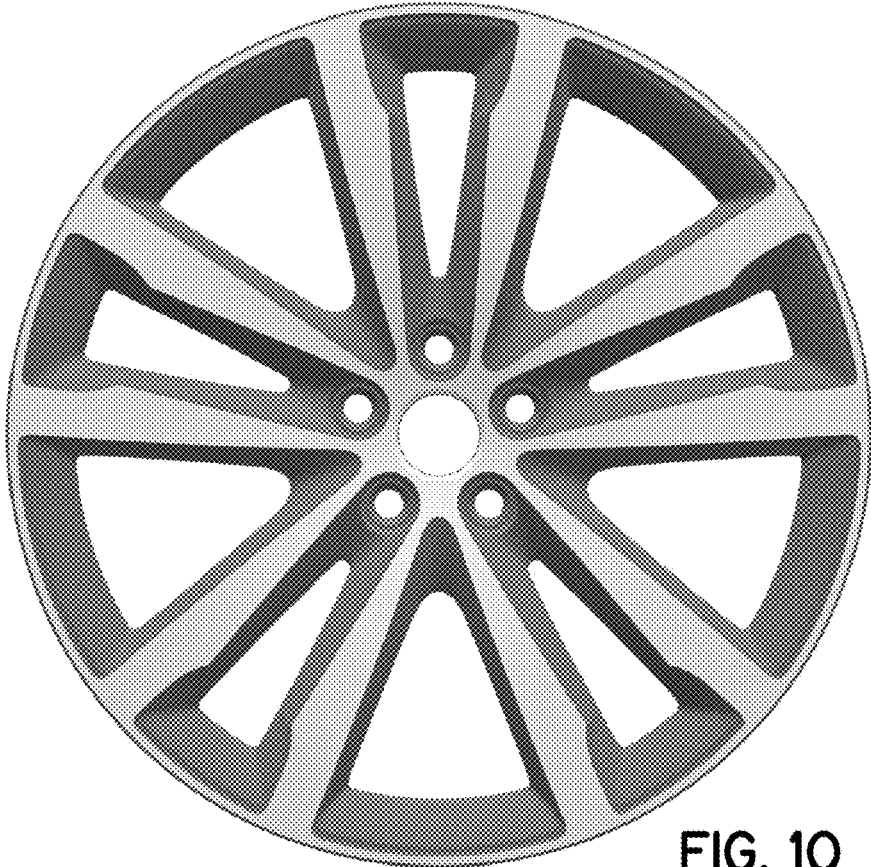

FIG. 10

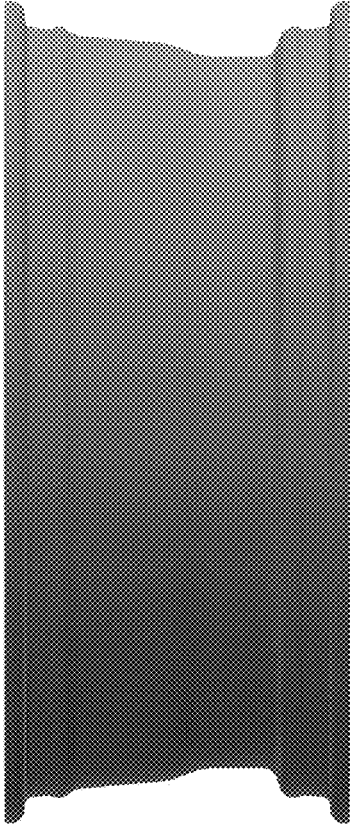

FIG. 11



FIG. 12



FIG. 13



FIG. 14