



(86) Date de dépôt PCT/PCT Filing Date: 2010/07/29
 (87) Date publication PCT/PCT Publication Date: 2011/02/03
 (85) Entrée phase nationale/National Entry: 2012/03/28
 (86) N° demande PCT/PCT Application No.: US 2010/043798
 (87) N° publication PCT/PCT Publication No.: 2011/014710
 (30) Priorités/Priorities: 2009/07/29 (US61/229,697);
 2010/04/15 (US61/324,677); 2010/07/28 (US12/845,645);
 2010/07/28 (US12/845,591)

(51) Cl.Int./Int.Cl. *G06Q 30/00* (2012.01),
G06Q 20/00 (2012.01), *G06Q 40/00* (2012.01)

(71) Demandeur/Applicant:
 VISA U.S.A. INC., US

(72) Inventeurs/Inventors:
 OLSON, RAY, US;
 MARTIN, JANET, US;
 NORRIS, MARK, US;
 BODINGTON, SHARON, US;
 STIFF, NICOLA, US;
 WOODS, ROSANN, US;
 CARR, JOHN, US

(74) Agent: MCMILLAN LLP

(54) Titre : SYSTEMES ET PROCEDES PERMETTANT D'OFFRIR DES AVANTAGES SELON DES
 CARACTERISTIQUES DE COMPTE
 (54) Title: SYSTEMS AND METHODS TO PROVIDE BENEFITS ACCORDING TO ACCOUNT FEATURES

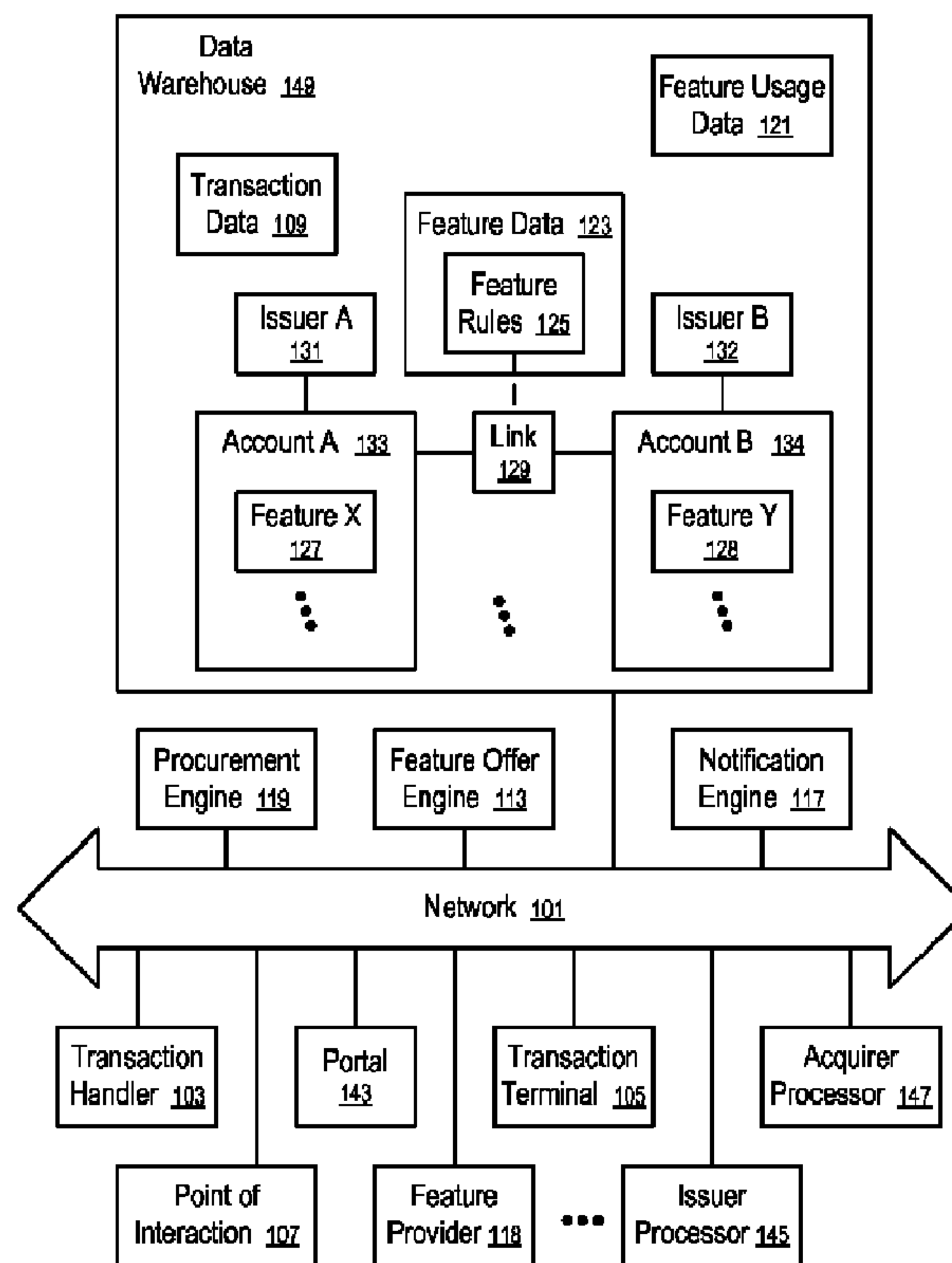

FIG. 1

(57) **Abrégé/Abstract:**

Systems and methods are provided to facilitate the sharing of account features and/or to facilitate the generation and notification of transactions associated with the account features. In one aspect, a system includes a transaction handler to process transactions



(57) **Abrégé(suite)/Abstract(continued):**

and a data warehouse to record the transactions and store account data identifying account features of separate accounts, such as a second account having a feature and a first account without this feature. Account holders of the first and second accounts are in a same household and thus, in accordance with a set of rules, eligible to share the account features. A portal is configured to receive a request identifying the first account and to determine whether a transaction initiated in the first account and qualified for a benefit of the account feature is entitled to the benefit; and if so, a notification engine is to transmit a notification message to an account holder of the first account. In another aspect, the data warehouse is to further store rules data identifying at least one qualification requirement. The system further includes a feature offer engine to use the rules data to monitor the transactions in the account to identify a first transaction. The notification engine is to provide the account holder with an offer associated with a first account feature in real time with processing of the first transaction, and the portal to receive an approval of a second transaction in accordance with the offer.

(12) INTERNATIONAL APPLICATION PUBLISHED UNDER THE PATENT COOPERATION TREATY (PCT)

(19) World Intellectual Property Organization
International Bureau(43) International Publication Date
3 February 2011 (03.02.2011)(10) International Publication Number
WO 2011/014710 A3

(51) International Patent Classification:

G06Q 30/00 (2006.01) G06Q 40/00 (2006.01)
G06Q 20/00 (2006.01)

(21) International Application Number:

PCT/US2010/043798

(22) International Filing Date:

29 July 2010 (29.07.2010)

(25) Filing Language:

English

(26) Publication Language:

English

(30) Priority Data:

61/229,697	29 July 2009 (29.07.2009)	US
61/324,677	15 April 2010 (15.04.2010)	US
12/845,591	28 July 2010 (28.07.2010)	US
12/845,645	28 July 2010 (28.07.2010)	US

(71) Applicant (for all designated States except US): VISA
U.S.A. INC. [US/US]; P.O. Box 8999, San Francisco,
California 94128-8999 (US).

(72) Inventors; and

(75) Inventors/Applicants (for US only): OLSON, Ray [US/
US]; 213 Correas Street, Half Moon Bay, California
94019 (US). MARTIN, Janet [US/US]; 5884 Teal Lane,
Long Grove, Illinois 60047 (US). NORRIS, Mark [GB/
US]; 1471 McAllister Street, San Francisco, California
94115 (US). BODINGTON, Shaun [GB/US]; P.O. Box
370241, Montara, California 94037 (US). STIFF, Nicola[US/US]; 620 Eucalyptus Way, Mill Valley, California
94941 (US). WOODS, Rosann [US/US]; 275 Princeton
Avenue, Mill Valley, CA 94941, US (US). CARR, John
[US/US]; 1383 S. Van Ness Avenue, San Francisco, CA
94110 (US).(74) Agent: WARD, John P.; Greenberg Traurig, LLP, 2450
Colorado Avenue, Suite 400 East, Santa Monica, CA
90404 (US).(81) Designated States (unless otherwise indicated, for every
kind of national protection available): AE, AG, AL, AM,
AO, AT, AU, AZ, BA, BB, BG, BH, BR, BW, BY, BZ,
CA, CH, CL, CN, CO, CR, CU, CZ, DE, DK, DM, DO,
DZ, EC, EE, EG, ES, FI, GB, GD, GE, GH, GM, GT,
HN, HR, HU, ID, IL, IN, IS, JP, KE, KG, KM, KN, KP,
KR, KZ, LA, LC, LK, LR, LS, LT, LU, LY, MA, MD,
ME, MG, MK, MN, MW, MX, MY, MZ, NA, NG, NI,
NO, NZ, OM, PE, PG, PH, PL, PT, RO, RS, RU, SC, SD,
SE, SG, SK, SL, SM, ST, SV, SY, TH, TJ, TM, TN, TR,
TT, TZ, UA, UG, US, UZ, VC, VN, ZA, ZM, ZW.(84) Designated States (unless otherwise indicated, for every
kind of regional protection available): ARIPO (BW, GH,
GM, KE, LR, LS, MW, MZ, NA, SD, SL, SZ, TZ, UG,
ZM, ZW), Eurasian (AM, AZ, BY, KG, KZ, MD, RU, TJ,
TM), European (AL, AT, BE, BG, CH, CY, CZ, DE, DK,
EE, ES, FI, FR, GB, GR, HR, HU, IE, IS, IT, LT, LU,
LV, MC, MK, MT, NL, NO, PL, PT, RO, SE, SI, SK,

[Continued on next page]

(54) Title: SYSTEMS AND METHODS TO PROVIDE BENEFITS ACCORDING TO ACCOUNT FEATURES

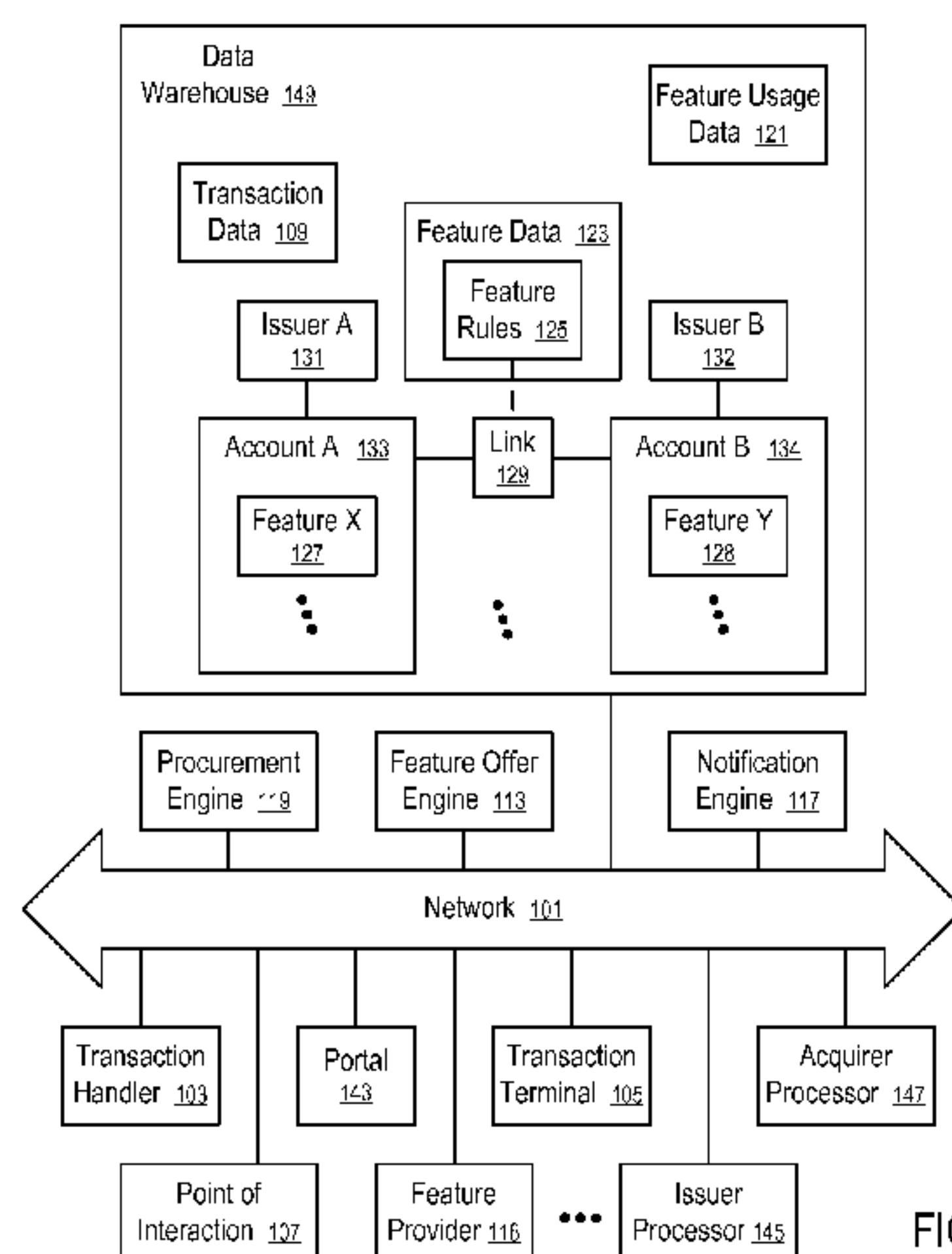

FIG. 1

(57) Abstract: Systems and methods are provided to facilitate the sharing of account features and/or to facilitate the generation and notification of transactions associated with the account features. In one aspect, a system includes a transaction handler to process transactions and a data warehouse to record the transactions and store account data identifying account features of separate accounts, such as a second account having a feature and a first account without this feature. Account holders of the first and second accounts are in a same household and thus, in accordance with a set of rules, eligible to share the account features. A portal is configured to receive a request identifying the first account and to determine whether a transaction initiated in the first account and qualified for a benefit of the account feature is entitled to the benefit; and if so, a notification engine is to transmit a notification message to an account holder of the first account. In another aspect, the data warehouse is to further store rules data identifying at least one qualification requirement. The system further includes a feature offer engine to use the rules data to monitor the transactions in the account to identify a first transaction. The notification engine is to provide the account holder with an offer associated with a first account feature in real time with processing of the first transaction, and the portal to receive an approval of a second transaction in accordance with the offer.

WO 2011/014710 A3



SM, TR), OAPI (BF, BJ, CF, CG, CI, CM, GA, GN, GQ,
GW, ML, MR, NE, SN, TD, TG).

— *before the expiration of the time limit for amending the
claims and to be republished in the event of receipt of
amendments (Rule 48.2(h))*

Published:

— *with international search report (Art. 21(3))*

(88) Date of publication of the international search report:
28 April 2011

**SYSTEMS AND METHODS TO PROVIDE BENEFITS
ACCORDING TO ACCOUNT FEATURES**

RELATED APPLICATIONS

[0001] The present application claims the benefit of the earlier filing dates of provisional U.S. Pat. App. Ser. No. 61/229,697, filed Jul. 29, 2009 and entitled “System and Method for Determining and Assigning Customized Enhancement Features to Financial Presentation Devices,” provisional U.S. Pat. App. Ser. No. 61/324,677, filed Apr. 15, 2010 and entitled “System and Method for Providing Customized Enhancement Features Associated with Past Transactions,” U.S. Pat. App. Ser. No. 12/845,645, filed Jul. 28, 2010 and entitled “Systems and Methods to Generate Transactions According to Account Features,” and U.S. Pat. App. Ser. No. 12/845,591, filed Jul. 28, 2010 and entitled “Systems and Methods to Provide Benefits of Account Features to Account Holders,” the disclosures of which applications are hereby incorporated herein by reference.

[0002] The present application relates to U.S. Pat. App. Ser. No. 12/025,267, filed Feb. 4, 2008 and entitled “System and Method for Managing Enhancement Features Assigned to Financial Presentation Devices,” the disclosure of which application is hereby incorporated herein by reference.

FIELD OF THE TECHNOLOGY

[0003] At least some embodiments of the present disclosure relate to a data processing apparatus, and more particularly a system to manage account features assigned to financial accounts that can be used to make payments for goods and services.

BACKGROUND

[0004] Credit cards, debit cards, prepaid cards, stored value devices and smart tag devices can be used to pay for goods and services without using cash. Such financial presentation devices are associated with financial accounts identified by account numbers. In the case of a credit card, the account number typically has a 16 digit card number embossed on the card. The 16 digit number consists of an initial 6 digit Bank Identification Number (BIN), followed by a 10 digit number. The BIN identifies the issuer bank that issued the card. The remaining

10 digit number identifies a particular card issued by the issuer. Accordingly, the 16 digit number on the credit card uniquely identifies a card and therefore the cardholder or account holder.

[0005] Over the years, the card issuers have developed different card types to more effectively target a variety of customer segments and to serve customer needs and increase card usage at the same time. Different types of cards are assigned different account features, or enhancement features.

[0006] Enhancement features are typically services or goods that a card issuer provides in addition to processing purchase transactions. Examples of enhancement features include zero liability from loss of card, auto rental collision damage waiver, emergency cash disbursement and card replacement, lost/stolen card reporting, extra warranty period for products, travel accident insurance, lost luggage reimbursement, roadside dispatch, cash back and frequent flyer mileage, airport lounge access, extra warranty period and companion airline ticket.

[0007] Conventionally, the account features are assigned to a card type; and card types are identified by the 6 digit BIN or the 9 digit BIN range of the account number. In other words, account features are determined by the initial 6 or 9 digits of the account number. Accordingly, when a cardholder contacts a provider of an enhancement feature, the provider only needs to ask for the initial 6 or 9 digits of the account number to determine whether the cardholder is entitled to a particular enhancement feature.

SUMMARY OF THE DESCRIPTION

[0008] Systems and methods are provided to facilitate the sharing of account features and/or to facilitate the triggering of transactions associated with account features. Some embodiments are summarized in this section.

[0009] In one aspect, a computer-implemented method includes: storing account data identifying account features of a plurality of separate payment accounts; receiving data identifying a first payment account that does not have a particular account feature; identifying at least one second payment account that is related to the first payment account; and determining whether a user of the first payment account is eligible for a benefit of the account feature based on whether the account data indicates that the at least one second payment account has the account feature.

[0010] In another aspect, a system includes: a transaction handler to process transactions; and a data warehouse to store transaction data recording the transactions processed at the transaction handler, a set of rules, and account data identifying account features of a plurality of separate accounts, including a first account that does not have an account feature and a second account that has the account feature, where account holders of the first account and the second account are in a same household. The system further includes a portal, or a feature offer engine, to determine, based on the set of rules, whether a transaction initiated in the first account and qualified for the benefit of the account feature is entitled to the benefit.

[0011] In a further aspect, a computer-implemented method includes: storing account data identifying at least one account feature of an account to provide a benefit to an account holder of the account; storing rules data identifying at least one qualification requirement associated with identification of transactions that qualify for the benefit of the account feature; monitoring transactions in the account using the rules data; based on the monitoring, identifying a first transaction that qualifies for the benefit of the account feature; and providing the account holder with a notification of a second transaction to be generated according to the account feature, prior to generation of the second transaction.

[0012] In a further aspect, a system includes: a transaction handler to process transactions; a data warehouse to store transaction data recording the transactions processed at the transaction handler, account data identifying at least one account feature of an account, and rules data identifying at least one qualification requirement; a feature offer engine coupled to the data warehouse to use the rules data to monitor the transactions in the account to identify a first transaction; and a notification engine to provide the account holder with an offer associated with a first account feature in real time with processing of the first transaction.

[0013] The disclosure includes methods and apparatuses which perform these methods, including data processing systems which perform these methods, and computer readable media containing instructions which when executed on data processing systems cause the systems to perform these methods.

[0014] Other features will be apparent from the accompanying drawings and from the detailed description which follows.

BRIEF DESCRIPTION OF THE DRAWINGS

[0015] The embodiments are illustrated by way of example and not limitation in the figures of the accompanying drawings in which like references indicate similar elements.

[0016] **Figure 1** shows a system to enable feature sharing in a plurality of accounts according to one embodiment.

[0017] **Figure 2** shows a system to generate a transaction according to one embodiment.

[0018] **Figures 3 – 9** illustrate user interfaces to manage an account according to one embodiment.

[0019] **Figure 10** shows a method to provide the benefit of an account feature according to one embodiment.

[0020] **Figure 11** shows a method to trigger a transaction according to one embodiment.

[0021] **Figure 12** shows a method to process a transaction according to one embodiment.

[0022] **Figure 13** shows a method to adjust account features according to one embodiment.

[0023] **Figure 14** shows a system to provide transaction based information according to one embodiment.

[0024] **Figure 15** illustrates a transaction terminal according to one embodiment.

[0025] **Figure 16** illustrates an account identifying device according to one embodiment.

[0026] **Figure 17** illustrates a data processing system according to one embodiment.

DETAILED DESCRIPTION

[0027] The following description and drawings are illustrative and are not to be construed as limiting. Numerous specific details are described to provide a thorough understanding. However, in certain instances, well known or conventional details are not described in order to avoid obscuring the description. References to one or an embodiment in the present disclosure are not necessarily references to the same embodiment; and, such references mean at least one.

[0028] In one embodiment, a centralized data service is provided to identify the account features at account level. Thus, each account can have a customized set of account features, independent of other accounts that share a common portion of account numbers (e.g., the initial 6 or 9 digits of account numbers).

[0029] In one embodiment, the features of the accounts are specified in a centralized data warehouse for individual accounts, instead of individual account types. The feature specification of one account, initially having the same set of features as a set of other accounts, can be changed without affecting the feature specifications of that set of other accounts and without having to use a different account number. Some details on managing enhancement features at the account level according to one embodiment are provided in U.S. Pat. App. Ser. No. 12/025,267, filed Feb. 4, 2008 and entitled "System and Method for Managing Enhancement Features Assigned to Financial Presentation Devices," the disclosure of which is hereby incorporated herein by reference.

[0030] In one aspect, systems and methods are provided to allow a group of financially connected accounts, such that the accounts held by one or more members in a household, to share account features. When a number of account holders are likely to share financial resources, a feature sharing arrangement can be provided to improve experience. Through the sharing arrangement, the benefit afforded by an account feature of one of the accounts can be extended to the other accounts in the group. The members in the group can share the benefits of the account features without having to physically share the account identification devices, such as credit cards, debit cards, etc.

[0031] For example, a married couple might have different accounts from the same issuer. The accounts may have different sets of account features. For example, while the account of the wife is entitled to Price Protection on all retail purchase through the use of her consumer credit card, the account of the husband is not. Through the sharing arrangement, the Price Protection feature is extended to the account of the husband. In one embodiment, upon the identification of the qualification for sharing in view of the rule set governing the sharing arrangement, the benefit of this Price Protection feature is automatically extended to the account of the husband. In another embodiment, upon the identification of qualification for this Price Protection feature, the husband is presented with the offer to add this feature to his account.

[0032] In another aspect, systems and methods are provided to trigger further transactions in response to certain transactions qualifying for offers associated with account features, such as a purchase to take advantage of the benefit of an account feature previously assigned to the account or the purchase of the account feature if it is not already in the account. In one embodiment, the account holder is notified of the further transaction triggered by the qualifying transaction. In one embodiment, the account holder is provided with an option to approve or disapprove the triggered transaction.

[0033] For example, one account feature provides premium trip cancellation coverage. If the account is used to pay for a purchase, such as an airline ticket, qualifying for the benefit of the coverage and the account does not already have this account feature, a notification is provided to the account holder to enroll in the account feature, with a fee or without a fee. In one embodiment, the account feature is added without the need for further input from the account holder. In another embodiment, the approval from the account holder is required to add the account feature. If the account has this feature for premium trip cancellation coverage, the qualifying purchase, such as the airline ticket, is to trigger a transaction to purchase insurance at a predefined fee in accordance with the account feature. In one embodiment, a notification is provided to the account holder about the insurance purchase. In one embodiment, the account holder is provided with a choice to approve or disapprove the insurance transaction triggered by the qualifying purchase.

[0034] Further details and/or aspects are provided below.

[0035] **Figure 1** shows a system to enable feature sharing in a plurality of accounts according to one embodiment. In **Figure 1**, the feature rules (125) allow the identification of the link (129) between account A (133) and account B (134) for feature sharing. The presence of the link (129) allows a feature sharing arrangement between account A (133) and account B (134). In some instances in this description, feature sharing is also referred to as householding, such as when the sharing is among account holders who are in the same household. In one embodiment, the feature rules (125) include a householding rule set established by a transaction handler (103), or an issuer (131 or 132). The benefit of householding (e.g., through account linking and multi-card grouping) is to entitle an individual or group of individuals to card features they would either not be entitled to, or features that would not normally be shared across cards accounts for different products or for the benefit of additional features.

[0036] For example, in one embodiment, account A (133) has feature X (127) but not feature Y (128); and account B (134) has feature Y (128) but not feature X (127). The presence of the link (129) allows the account holder of account B (134) to receive the benefit afforded by feature X (127) of account A and the account holder of account A (133) to receive the benefit afforded by feature Y (128) of account B (134).

[0037] In one embodiment, account A (133) is from issuer A (131); and account B (134) is from issuer B (132), which is different from issuer A (131). In some embodiments, the feature sharing is allowed between accounts (133 and 134) when the issuers (131 and 132) are the same. In some embodiments, the feature sharing is allowed even when the issuers

(131 and 132) are different. In one embodiment, the feature rules (125) specify the conditions that are to be met to establish the link (129).

[0038] In one embodiment, householding or feature sharing includes identifying and linking multiple accounts (e.g., 133 and 134) having a common attribute set for the purpose of shared entitlement to account features (or card features). For example, in one embodiment, householding is permitted when the accounts (133 and 134) share at least one account holder. For example, in one embodiment, householding is permitted when the accounts (133 and 134) are held by persons in the same household, such as husband and wife. For example, in one embodiment, householding is not permitted when the billing addresses of the accounts (133 and 134) are different and/or the accounts (133 and 134) do not share a common account holder.

[0039] In one embodiment, individual account holders can use the portal (143) to manage the householding relationship and/or select account features. For example, in one embodiment, the account holder of account A (133) is to use the portal (143) to request the link (129) between accounts A and B (133 and 134) for householding. When the request is permitted by the feature rules (125) established by the transaction handler (103), issuer A (131) of account A (133) and/or issuer B (132) of account B (134), the link (129) is established between account A (133) and account B (134).

[0040] In one embodiment, the portal (143) is coupled to the data warehouse (149) via the network (101). The portal (143) communicates with the point of interaction (107) of account holders to provide user interfaces to customize the feature sets of the corresponding accounts (e.g., 133, 134) of the account holders.

[0041] In one embodiment, the permission for feature sharing is granted to individual features. For example, in one embodiment, after the link (129) is established to indicate that accounts A and B (133 and 134) satisfy the relationship requirement for householding, the sharing of individual features is further based on the feature rules (125) and the requests or authorizations from the account holders. For example, in one embodiment, one feature in account A (133) is extended to account B (134) while another feature in account A (133) is not extended to account B (134). For example, one or more features in account B (134) is extended to account A (133), while other features in account B (134) are not available to account A (133), in accordance with the feature rules (125) and/or the preferences of the account holders.

[0042] In one embodiment, the feature offer engine (113) is to examine the account data in view of the feature rules (125) to identify the link (129), without the account holders

having to make explicit requests. In some embodiments, the feature offer engine (113) is to identify the features that can be extended via householding and then provide offers to the respective account holders for authorization and/or confirmation.

[0043] In one embodiment, to implement the feature sharing or householding, the data warehouse (149) is to store a table of entities (e.g., households, employers, or cardholders for multiple cards) with each entity storing information identifying associated accounts. In one embodiment, the link (129) represents such an entity.

[0044] In one embodiment, the system in **Figure 1** includes a procurement engine (119) to manage feature data (123) of features (e.g., 127, 128) assigned or to be assigned to the accounts.

[0045] For example, different feature providers (e.g., 118) may use the procurement engine (119) to provide bids to offer services or products involved in the fulfillment of the features. The transaction handler (103) and/or the issuers (e.g., 131 and 132) may select the services or products recorded in the feature data (123) based on the offers from the feature providers (e.g., 118).

[0046] In one embodiment, the costs of the features are sponsored by the issuers (e.g., 131, 132), the transaction handler (103), or a third party, such as the feature provider (118). In one embodiment, the costs of the features are shared among multiple parties, such as an issuer (e.g., 131 or 132), the transaction handler (103), a third party, such as the feature provider (118), and/or the account holder. In one embodiment, the costs of the features are mainly paid for by the account holder, with a discount or incentive provided by the issuer (e.g., 131 or 132), the transaction handler (103), and/or a third party, such as the feature provider (118).

[0047] In **Figure 1**, the transaction handler (103) is to process transactions between an acquirer processor (147) and an issuer processor (145). The acquirer processor (147) is connected via the network (101) to the transaction terminal (105) that is typically associated with a merchant. The acquirer processor (147) processes the transactions on behalf of the merchant; and the issuer processor (145) processes the transactions on behalf of the account holder. In one embodiment, more than one acquirer processor (147) is connected to the transaction handler (103) via the network (101); more than one issuer processor (145) is connected to the transaction handler (103) via the network (101); and the transaction handler (103) connects the acquirer processor (147) to the issuer processor (145) for the respective transaction based on the identity of the issuer (e.g., 131 or 132) of the account (e.g., 133 or 134) used to make the payment for the transaction. In one embodiment, the transaction

handler (103) acts as a switch between acquirers and issuers for routing messages therebetween for purposes of authorization, clearing and/or settlement of financial transactions.

[0048] In one embodiment, the transaction handler (103) stores the transaction data (109) recording the transactions processed at the transaction handler (103) for one or more acquirers and for one or more issuers (e.g., 131, 132). The transaction data (109) can be used to customize offers to the account holders, as discussed below.

[0049] In one embodiment, the portal (143) of the transaction handler (103) provides the centralized location to access the data related to and/or the benefits of the features (e.g., 127, 128). For example, in one embodiment, when the account holder of account A (133) contacts the services or products of the feature provider (118) for the benefit of a feature (e.g., 127) of account A (133), the feature provider (118) is to use the portal (143) to determine when the account holder is eligible for the benefit. For example, in one embodiment, an account holder is to use the portal (143) to claim the benefit of an account feature (e.g., 127 or 128).

[0050] In one embodiment, the portal (143) and the data warehouse (149) provide an aggregate view and feedback from feature providers (e.g., 118) on usage and trend analysis. Similarly the portal (143) provides account holders with an aggregate view of the account features (e.g., 127, 128) and/or services or benefits available in their accounts (e.g., 133, 134). The portal (143) provides a centralized location from which to request or process services.

[0051] In one embodiment, the notification engine (117) is to notify the account holder via an email, a text message, a voice message, etc., when a transaction of the account holder qualifies for the benefit of a feature (e.g., 127), or when the account holder is eligible for the offer of an account feature. In one embodiment, the notification is in real time as the transaction is being processed by the transaction handler (103). In one embodiment, the notification is provided after the transaction is settled.

[0052] In one embodiment, feature usage data (121) is recorded in the data warehouse (149). The feature offer engine (113) is to use the feature usage data (121) and/or the transaction data (109) to offer or recommend features for the account holders. For example, a feature (e.g., 127) can be provided as a reward to an account holder, if the transaction data (109) indicates that spending of the account holder satisfies one or more thresholds. For example, the feature offer engine (113) may use the transaction data (109) and the feature usage data (121) to identify spending patterns of account holders that use a particular feature

(e.g., 127) and the identify account holders having similar spending patterns in offering the particular feature (e.g., 127).

[0053] In one embodiment, the account features (e.g., 127 and 128) are linked not only to the account (e.g., 133 and 134) but also to the form factor of the account identification devices. Examples of form factors include a traditional, plastic wallet-sized card, a small card adapted to be attached to key chain, radio frequency identification (RFID) card, mobile phone, etc. At least some of the account features specified by the feature data (123) are offered based on the form factor of the account identification device of the respective accounts (e.g., 133, 134). Thus, the account features (e.g., 127 and 128) are truly of value to both the account holders and the owners or issuers of the form factors.

[0054] In one embodiment, the integration of the delivery of account features (e.g., 127 and 128) with the transaction handler (103) includes the collection of data from multiple sources to derive intelligence, including the transaction data (109), the feature data (123), the feature usage data (121), and associated data from feature providers (e.g., 118) and other entities associated with the fulfillment of the services and/or products offered by the account features, such as vendors, administrators, customer service providers, suppliers, merchants, etc.

[0055] In one embodiment, integrations are performed at multiple different levels to offer account features in an individualistic (individual card level) manner. In one embodiment, the feature offer engine (113) performs data aggregation and filtering for recommending features and assigning features. In one embodiment, the feature data (123) includes a collection of information, such as services and/or products procurement inventory that can be used for the fulfillment of the benefits of the account features, form factor information, consumer segmentation/portfolio overlay data, etc.

[0056] In one embodiment, the feature offer engine (113) determines feature propensity scores based on the transaction patterns reflected in the transaction data (109), and the use the feature propensity scores to offer or award account features. In one embodiment, the aggregated spending (e.g., in an account, and/or in a category) is compared to a threshold to determine whether an account or an account holder is eligible for an account feature.

[0057] In one embodiment, the feature offer engine (113) is to identify and/or validate the links (e.g., 129) among accounts (e.g., 133 and 134) for feature sharing or householding.

[0058] In one embodiment, the feature offer engine (113) is to identify events, transactions, etc., that lead to further transactions to invoke the benefit of the account features (e.g., 127, 128), or that lead to loyalty benefits, or rewards. The notification engine (117) is

to inform the respective account holders of the opportunity for the transactions and/or the loyalty benefit or rewards.

[0059] In one embodiment, the system illustrated in **Figure 1** uses the aggregated and/or filtered data for offer presentment, account holder enrollment, transaction qualification, notification to account holders, enhancements based on usage, and automatic “For Fee” transaction generation based on vendor “best offer.”

[0060] In one embodiment, the system illustrated in **Figure 1** includes the transaction handler (103) recording the transaction data (109), the feature offer engine (113) to aggregate and filter data for account feature offers, a procurement engine (119) to organize feature providers (e.g., 118) and feature bidding, and the portal (143) and the notification engine (117) for feature presentation, servicing, customization, personalization, including a user interface to Build Your Own (BYO) feature set, as illustrated in **Figures 3 – 7**. In one embodiment, the system further includes a feature workflow engine to manage the benefit fulfillment of the account features (e.g., 127, 128).

[0061] In one embodiment, the feature offer engine (113) derives intelligence information from the data warehouse (149) for the fulfillment of the benefits of the account features, such as an automated linkage between the “trigger” transaction and a feature.

[0062] For example, in one embodiment, the applicable account feature is marketed via the notification engine (117) after a cardholder’s purchase of a qualifying transaction. The qualifying transaction triggers One-on-One marketing to the cardholder for the appropriate “Feature.”

[0063] **Figure 2** shows a system to generate a transaction according to one embodiment. In **Figure 2**, the feature rules (125) are used to define the trigger (303) which is to generate transaction B (305) in response to transaction A (301) that meets the requirements of the trigger (303).

[0064] In one embodiment, the transaction handler (103) processes transaction A (301) and generates transaction data (109) about the transaction A (301), the feature offer engine (113) coupled to the data warehouse (149) and/or the transaction handler (103) is to detect transaction A (301) that satisfies the requirements of the trigger (303).

[0065] In one embodiment, in response to the detection of transaction A (301) that can trigger transaction B (305) in accordance with the feature rules, the feature offer engine (113) is to use the notification engine (117) and/or the portal (143) to notify the account holder and/or receive approval from the account holder.

[0066] For example, in one embodiment, the notification engine (117) is to transmit a notification message (311) about an offer associated with transaction B (305) to the point of interaction (107) of the account holder. The account holder may use the same point of interaction (107), or a different one, to provide the approval message (313) to the feature offer engine (113) via the portal (143).

[0067] In one embodiment, the feature offer engine (113) is to submit transaction B (305) to the transaction handler (103) upon receiving the approval message (313) from the account holder.

[0068] In some embodiments, the approval message (313) is not necessary for the feature offer engine (113) to initiate transaction B (305), such as when the account holder pre-approves such transactions in advance with a preference setting, or when the account holder does not provide a disapproval message within a predetermined period of time.

[0069] As an example, assume that the feature (e.g., 127) provides the benefit of a premium trip cancellation coverage at a discounted price. For example, the feature (e.g., 127) is to provide premium trip cancellation coverage at a discounted price (e.g., \$35 instead of \$50) for each airline ticket purchase transaction if the account holder adds the feature (e.g., 127) to the account (e.g., 133). The feature offer engine (113) is to use the account information and/or purchase history to determine or identify a particular account holder based on some predetermined criteria (e.g., account holders with an annual spend in the travel category of \$30,000 who have also purchased at least one trip cancellation insurance within the last two years).

[0070] In one embodiment, if the feature (e.g., 127) is not already in account A (133) and the account holder of account A (133) is eligible for the feature (e.g., 127), the feature offer engine (113) is to market the feature (e.g., 127) to the account holder at the point of interaction (107). In one embodiment, the feature offer engine (113) is to offer the account holder to enroll or accept the feature (e.g., 127) via a communication in the form of an email with a hyper-link to register for the offer, a mobile message, a text message, a voice message, a direct mail with instructions to enroll, a website and the like.

[0071] In one embodiment, after the account holder enrolls in the program provided by the account feature (e.g., 127) (through a web portal (143), for example), each airline ticket purchase triggers (e.g., 303) an additional purchase transaction (e.g., 305) in the account (e.g., 133) is automatically generated for the price of the Premium Trip Cancellation Coverage (e.g., at the discounted price afforded by the account feature (e.g., 127)).

[0072] The notification engine (117) can use a one-way or two-way communication to market the additional purchase (e.g., 305) to the account holder and/or to allow the account holder to either decline or cancel the purchase. The notification of the optional purchase for the coverage (e.g., at the discounted price) provided under the feature (e.g., 127) is to be communicated to the targeted account holder via an email, a text/SMS message, a voice message, etc.

[0073] In one embodiment, the enrollment to the account feature (e.g., 127) in the account (e.g., 133) is to be in effect until being terminated by the account holder, or until the account holder is no longer eligible for the account feature (e.g., 127) in accordance with the feature rules (125). When the account feature (e.g., 127) is in effect for the account (e.g., 133), the Premium Trip Cancellation Coverage is to be purchased for each airline ticket paid using the account (e.g., 133).

[0074] In one embodiment, the account feature (e.g., 127) has an alert option, which when selected provides the respective account holder with an alert for the “For Fee” transaction triggered by a qualifying transaction in connection with the account feature (e.g., 127).

[0075] In one embodiment, the notification engine (117) provides a one-way alert to the account holder via an email, a text message, a voice message. The one-way alert is to notify the account holder that a qualifying transaction (e.g., purchase of an airline ticket) has occurred and the associated benefit (e.g., trip cancellation coverage) is to be provided for that travel arrangement. In addition, the one-way alert may also indicate that a “For Fee” enhancement transaction (e.g., \$35 cancellation insurance) will be generated. The one-way alert may also provide contact information if the account holder wants to cancel the “For Fee” transaction.

[0076] In another embodiment, the notification engine (117) is to facilitate a two-way alert. The two-way alert can be used in several different ways. In one way, it can send a message to the account holder as described above and allow the account holder to approve the “For Fee” enhancement transaction prior to the transaction being performed. Ideally, this positive response can reduce the requirements for credit and exception processing related to the original purchase transaction. In another way, it can send a message to the account holder as described above and offer an upgrade of the purchased enhancement (e.g., higher travel insurance coverage) or additional related enhancements (e.g., airport lounge day pass).

[0077] In one example, the account feature (e.g., 127) is to provide a benefit via statement credits when the account holder makes a triggered transaction (e.g., 305) that is

entitled to the benefit of the account feature (e.g., 127). For example, in one embodiment, the triggered transaction (e.g., 305) is the purchase of an airport lounge day pass; and the statement credits are provided to effectively reduce the price of the purchase, or to make the purchase effectively free of charge.

[0078] In one embodiment, the triggered transaction (e.g., 305) is in response to a triggering transaction (e.g., 301) when an aggregated spending threshold is satisfied. For example, in one embodiment, the spending threshold is satisfied when the account (e.g., 127) having the account feature (e.g., 127) is used to purchase a predetermined number of airline tickets, spend a predetermined amount of money in a period of time (e.g., a month or a year), and/or make a predetermined number of transactions in a category, such as a travel category that includes spending on airline, hotel, car rental, etc. For example, in one embodiment, the account feature (e.g., 127) offers the account holder a free airport lounge day pass when the corresponding account (e.g., 133) is used to purchase five airline tickets, or spend at least \$5000 per month, or make twenty five travel transactions per month (for airline, hotel, or car rental). For example, the account feature (e.g., 127) offers the account holder two free airport lounge day passes when the account (e.g., 133) is used to purchase eight airline tickets

[0079] In one embodiment, the triggering transaction is the transaction the addition of which causes the threshold to be met. In one embodiment, the triggering transaction is the transaction in a specific category, such as the purchase of an airline ticket, after the spending or loyalty threshold is satisfied. In one embodiment, the benefit of the account feature (e.g., 127) is provided as a loyalty program.

[0080] In one embodiment, the notification of the benefit of the triggered transaction (e.g., 305) is provided in response to the triggering transaction (109) being processed by the transaction handler (103). In one embodiment, the notification of the benefit of the triggered transaction (e.g., 305) is provided in response to the location of the account holder, after the triggering transaction (109) is processed by the transaction handler (103).

[0081] In one embodiment, the benefit provided to the triggered transaction (e.g., 305) is provided to the account holder via the statement credit after the transaction handler (103) processes the triggered transaction (305) using the account (e.g., 133). The transaction handler (103) or the feature offer engine (133) is to recognize the triggered transaction (e.g., 305) from the transaction data (109) and thus automatically communicate with the issuer processor (e.g., 145) to provide the statement credit. Thus, the account holder does not have to present a coupon or similar item to claim the benefit. This reduces burdens on the account holder and thus improves user experience. Alternatively or in combination, the notification

engine (117) may provide an electronic coupon or discount code with the notification of the eligibility of the triggered transaction (305) for the benefit of the account feature (e.g., 127).

[0082] In one embodiment, the transaction handler (103) is to monitor transactions to detect the trigger (303). Alternatively, a separate engine, such as the feature offer engine (113), is configured to access the transaction data (109) over the network (101) to detect the trigger (303). For example, the transactions can be monitored in real time for airline ticket purchase transactions; and for those transactions, they can be further compared to the list of account holders or accounts that have enrolled in the enhancement feature (e.g., 127).

[0083] In some embodiments, triggers (e.g., 303) are detected periodically from settled transactions.

[0084] An alternate scenario is a non-transaction trigger associated with the payment form-factor, for example, as an overall valuable customer.

[0085] In one embodiment, the triggers are also detected for the notification of benefits of account features that do not require an additional “for-fee” transaction. For example, the notification of benefits is to inform the account holder of the earning of reward points, rebate cash, discount, etc., triggered by qualifying transactions under loyalty programs.

[0086] In one embodiment, the feature offer engine (113) is to selectively offer features based on a spending threshold and/or a type of spending. For example, when the aggregated spending in a period of time (e.g., previous 12 months) in account A (133) is above a threshold, or when the aggregated spending having the type of spending in the account (133) is above the threshold, the account (133) is offer the feature (127).

[0087] In one embodiment, if the spending requirement is not met, the feature (127) is to be removed from the account (133).

[0088] In one embodiment, the spending requirement can be checked and/or enforced periodically, or in real time in response to transactions that may qualify for benefits of the feature (e.g., 127).

[0089] Thus, the system as illustrated in **Figure 1** enables an individual account holder to be granted a suite of features that could differentiate them from another card account for the same product in the same BIN. The feature set can be changed dynamically based on the spending of the account holder, the preferences of the account holder, and/or the preferences of the issuer (e.g., 131).

[0090] In one embodiment, the spending threshold requirement is to further introduces the flexibility of feature eligibility and determination based on spending in individual account

(e.g., 133), in household grouping (e.g., 129), or other types of grouping (e.g., a corporation, a circle of friends).

[0091] In one embodiment, qualifying criteria such as cumulative spending within a specified time period can be established for a type of spend within a merchant or merchant category group.

[0092] For example, in one embodiment, the feature rules (125) specifies the qualification of increased level of coverage for lost luggage reimbursement insurance if an account holder spends more than \$35K in the past 12 months, or an Issuer promotes a feature as a reward for establishing bill payment for utilities.

[0093] In one embodiment, the feature offer engine (113) is to assign feature propensity score as individualistic rating of account features (e.g., 127, 128) by account or account holder. The feature propensity score enables a framework to evaluate different drivers of value relative to the other. For example comparing usage of particular services or features at a service provider with spending analysis and awareness of a feature. In one embodiment, the feature propensity score is a value ranking of a particular feature's value to an account holder, or likelihood of the account holder to purchase a feature, to make purchases under the feature, or to utilize the feature.

[0094] An example of a propensity score would be a score of 9 (on a scale of 0 to 10) for the likelihood that a particular account holder would purchase an airport lounge access. The score of 9 means there is a very high likelihood that the account holder would purchase such product.

[0095] In one embodiment, the propensity score is computed based at least in part on the transaction data (109) recorded for the respective account (e.g., 133, or 134).

[0096] In one embodiment, the feature offer engine (113) uses the propensity score to determine whether or not to offer the corresponding feature to an account holder.

[0097] In one embodiment, the data warehouse (149) includes a number of complementary data elements that would be used by the feature offer engine (113), the procurement engine (119), the notification engine (117), and/or the portal (143). Such data elements includes a list of generic enhancement or feature benefits available to specific portfolios and/or segments, demographic or physiographic segmentations of account holders, a list of suppliers of features that are qualified to be part of the feature provider network or the procurement engine to bid for providing the services or products for the fulfillment of the features, a list of form factors (e.g., types) of account identification devices (e.g., card, mobile

device, contactless payment device such as RFID devices), and/or an array indicating the individual features, benefits or services specific to an account or an account holder.

[0098] In one embodiment, the feature offer engine (113) is to determine a feature offer set that identifies the recommended feature or features based on the outcome of the processing of feature rules (125) and available inventory according to feature data (123). The feature offers are provided to the respective account holders via various marketing channels, such as white spaces available on the point of interaction (107), as discussed in the section entitled “POINT OF INTERACTION.”

[0099] In one embodiment, a network of approved feature providers (e.g., 118) or vendors are either a preferred suppliers of features or service providers and issuers. The procurement engine (119) is to communicate with the approved vendors to collect the feature data (123) about features (e.g., 127, 128) that can be offered to the account holders. In one embodiment, a workflow engine manages controlled usage, business process adherence, communication and approvals in connection with the features (e.g., 127, 128).

[00100] In one embodiment, the system illustrated in **Figure 1** uses the data warehouse (149) to provide a turnkey servicing solution for feature enrollment, billing, notification, customer relation management, and reporting.

[00101] In one embodiment, the portal (143) includes a Multi-channel communication and account holder facing portal (Design/Build Your Own BYO), within which features are presented, offered and/or managed in a way as illustrated in **Figures 3 – 9**.

[00102] For example, in **Figure 3**, the account holder (or a potential account holder) is provided with the interface (210) to select the reward program assigned to the account (e.g., 133). The interface (210) can be presented via a web server of the portal (143) and a web browser running on the point of interaction (107) of the account holder.

[00103] In one embodiment, a set of radio buttons (211) allows the account holder to select one of the reward programs; and the links (215) can be selected to view details of the reward programs. In some embodiments, the user is allowed to switch from one reward program to another for a particular account (e.g., 133) without have to change the account number. The account holder is to select the “continue” button (213) to save the selected reward option and to navigate to the next screen of options of account features, as illustrated in **Figures 4 – 7**.

[00104] **Figure 4** illustrates an interface showing a set of core features that are provided to the account holder without additional cost.

[00105] **Figure 5** illustrates an interface showing a list of packages that are conveniently grouped as packages for presentation to the account user. In one embodiment, the account holder is to select exact one package. In other embodiments, the account holder may select no package, or more than one package.

[00106] **Figure 6** illustrates an interface showing a set of features provided in one package. In one embodiment, the account holder has the option to select all the features in the package, or a subset of the features in the package.

[00107] **Figure 7** illustrates an interface showing additional list of features that the account holder may individually select.

[00108] In one embodiment, some of the features (e.g., 127, 128) require a fee for enrollment (e.g., a monthly fee, an annual fee, etc.); and some of the features (e.g., 127, 128) require a per usage fee (e.g., a per call fee, a daily fee for access, a fee per claim, etc.).

[00109] **Figure 8** illustrates an interface showing options to set up notifications. For example, the account holder may provide the email address, a mobile phone number and/or a phone number in entry boxes (221) to receive notifications related to the events selected by the option buttons (e.g., 223).

[00110] For example, in one embodiment, the account holder is to select the option button (223) to request a notification be sent to the phone number specified in the entry box (221) associated with the text message whenever a feature benefit is available to the account holder. The selected preferences of the account holder are stored in the data warehouse (149) for the notification engine (117).

[00111] **Figure 9** illustrates an interface that allows the account holder of one account (133) to request a householding link (e.g., 129) with another account (e.g., 134). For example, in **Figure 9**, the account holder of account A (133) is to enter the account number of account B (134) in the entry box (225) to request the link (129).

[00112] In one embodiment, after the account holder of account A (133) requests the link (129), the account holder of the account B (134) is to provide a consent for the link (129) for householding via the portal (143) (or the notification engine (117)).

[00113] In one embodiment, after the feature offer engine (113) is to approve the request based on the feature rules (125). In one embodiment, the feature offer engine (113) is to automatically identify the candidate accounts that would qualify for householding links (e.g., 129) and offers the opportunity for establishing the householding links (e.g., 129) to the account holder.

[00114] In one embodiment, the portal (143) further provides support for feature queries, account holder queries, enrollment, servicing, to issues (e.g., 131, 132), the transaction handler (103), the feature providers (e.g., 118), etc.

[00115] Thus, in one embodiment, the portal (143) provides a 'Build Your Own' / 'Design Your Own' mechanism to enable consumer directed selections of account features (e.g., enhancements, benefits, services), and feature attributes such as, amending coverage levels on their accounts, individually and collectively either by 'household' or entity in the case of a small business.

[00116] In one embodiment, the account holder can use the portal (143) to manage features by individual card account and 'household' grouping. Account holder selections may be by feature suites or package (e.g., **Figure 5**), a la carte (e.g., **Figure 7**) or combination there of (e.g., **Figure 6**) and incur a fee which the can be debited directly from the account holder account by money or points.

[00117] In one embodiment, the account holder can use the portal (143) to tailor notification and alert options similar to targeted acceptance for feature reminders and offers based on transaction events (e.g., **Figure 8**).

[00118] In one embodiment, the account holder can use portal (143) to request aggregation and/or sharing of account features for individual or householding of multcards (e.g., **Figure 9**).

[00119] In one embodiment, the feature offer engine (113) is to determine qualifications for features (e.g., 127, 128) based on spending behavior, threshold qualification, and/or geographic card usage.

[00120] In one embodiment, the data warehouse (149) provides common services to a network of feature providers (e.g., 118), such as suppliers, vendors, program administrators, and/or issuers for procurement of account features, and associated services, claims tracking, account holder servicing, registration services (through self service or representatives), and integrated solutions with workflow.

[00121] In one embodiment, the system as illustrated in **Figure 1** enables business to business integrated billing of card feature provisioning and usage among issuers, suppliers and vendors, provides the ability for revenue share opportunities between Visa, vendors and issuers the with for fee account holder features, and provides a unified integration platform and database allowing issuers, service providers, suppliers vendors, third parties and account holders to utilize the features and functionality of the system.

[00122] One component of the system illustrated in **Figure 1** is a data identifying the features (e.g., 127, 128) of the accounts (e.g., 133 and 134) and their attributes such as effective dates and levels of coverage or value.

[00123] In one embodiment, the portal (143) provides interfaces (e.g., **Figures 3 – 9**) via Web UI or Web services to allow the account holder to design their own individual accounts (e.g., 133, 134) and select the features most relevant and applicable to them. The account holder selections are stored in the data warehouse (149) for lookup when servicing the account holder or by the feature offer engine (113) and/or the transaction handler (103) rules engine when monitoring for spending behavior, threshold qualification, or geographic card usage.

[00124] In one embodiment, the notification engine (117) uses the transaction triggers to provide notifications or alerts for up-sell and cross-sell opportunities, card feature reminders and reinforcement.

[00125] Additionally, merchant discounts could be offered based on the features (e.g., 127, 128) for the accounts (e.g., 133, 134) or aggregated for the ‘household’.

[00126] In one embodiment, the “Design Your Own” account holder selections are stored in the data warehouse (149) and shared with issuer back office systems. Fees associated with feature selections are billed directly to the respective benefiting accounts via the transaction handler (103).

[00127] In one embodiment, issuers (e.g., 131, 132) are to administer account features (127, 128) through a self service module, and where appropriate integrated workflow will allow the review and approval of feature changes and registration. Suppliers, such as the feature provider (118), are to add features to the features data (123) through the procurement engine (119); and the system of **Figure 1** is to allow procurement and billing of features by issuers (e.g., 131, 132).

[00128] In one embodiment, the system of **Figure 1** is implemented using the transaction handler (103) and its infrastructure with interfaces to alerts, transaction network, web application user interface, web services and Card Maintenance File processing via various endpoints. Client side interfaces on the point of interaction (107) are implemented either through a common web service interface or client side software that enables seamless integration to web portals, online banking, customer servicing applications and related business back office applications to ensure optimized and up to date data management.

[00129] In one embodiment, the system of **Figure 1** allows issuers (e.g., 131,132) to offer additional enhancement features or benefits to individual account holders. In one embodiment, the account features (e.g., 127, 128) charge a per use fee, which is to be billed to the respective account (e.g., 133, 134) of the account holder, when a transaction has been made for which the benefit qualifies. For example, when an eligible account holder purchases an airline ticket using account A (133), possibly during a specified time period, a benefit such as Travel Accident Insurance for up to \$1.5M can be offered in accordance with the feature X (127). In one embodiment, an account feature (e.g., 127) can provide variable options and pricing.

[00130] The following are additional examples of the types of transactions for which benefits may be offered in accordance with some account features in some embodiments.

[00131] A. Activation Rewards/Benefits: The account holder utilizes card for the first time and receives an additional benefit or incremental benefit, where fee may or may not apply.

[00132] B. Annual Spend Rewards: The issuer automatically upgrades account holder benefits when an annual spend threshold is surpassed. A fee may or may not be applied once the account holder's benefits have been upgraded.

[00133] C. Travel Transaction Benefits/Rewards: Based on airline ticket purchases, or car rental purchases an upgraded insurance or service based benefit is offered.

[00134] D. Protection Benefits/Rewards: Based on international travel, an additional benefit is awarded such as wallet protection, card replacement. Based on frequency in retail spending, an additional benefit, or upgraded benefit is provided, such as protection against identity theft, fraud monitoring, etc.

[00135] E. Merchant Loyalty: The account holder is awarded an additional merchant benefit based on frequent shopping at the merchant.

[00136] F. Account Holder Anniversary Benefits/Rewards: An issuer provides account holder an additional benefit (such as an offer, coupon, or points) on anniversary of first transaction or other identifiable milestone.

[00137] In one embodiment, a transaction triggered enhancement/benefit is provided according to an account feature (e.g., 127 or 128) on a per-account basis. In one embodiment, the feature data (123) includes a benefits database that stores the details of each benefit to be offered to the account holders. The feature usage data (121) includes a benefits database that stores actual benefits that have been purchased by or provided to the account holders. In one embodiment, the feature offer engine manages the benefits.

[00138] In one embodiment, issuer computers are to define eligible accounts (e.g., 133, 134) and send the data identifying the eligible accounts to data warehouse (149) (e.g., via the portal (143)) as a CMF (cardholder maintenance file) along with any rules (e.g., 125) that define criteria/rules for trigger.

[00139] For example, the eligible accounts may have been determined by the issuer to include only those that have an annual spend in a travel category of more than \$50,000; an example rule and trigger may be the purchase of any airline ticket during a specified time period in order to offer a discounted offering of lost luggage insurance. Alternatively, rules that define the criteria for transaction trigger may be provided by the transaction handler (103).

[00140] In one embodiment, account holder contact information is sent to an alert & approve system, such as the notification engine (117) and the portal (143). The transaction handler (103) or the feature offer engine (113) is to determine qualified transactions using the feature rules (125). In particular, the transaction handler (103) or the feature offer engine (113) is to review the transactions that have taken place and look for those that qualify under the feature rules for a transaction trigger (e.g., purchase of airline ticket during the specified time period by an account contained in the eligible accounts list).

[00141] In one embodiment, the transaction handler (103) or the feature offer engine (113) sends information about those qualified transactions to the account holders via the notification engine (117) and/or the portal (143).

[00142] In one embodiment, the notification engine (117) and/or the portal (143) are to track the responses from the respective account holders.

[00143] The communications about the qualified transactions can be a one-way notification or a two-way communication. The one-way notification is generally for those benefits for which the account holders have already given consent to in advance. The two-way communication is generally for those that require an explicit approval from the account holders. The communication can be an email, text message to a mobile phone or a telephone call by an interactive voice response (IVR) system which is capable of interacting with the user and receiving user responses through the telephone.

[00144] In one embodiment, an example message sent to the account holder who had previously given permission to receive promotional offers is “You have made a purchase that is eligible for Sign and Travel Benefit. To activate the Benefit reply back with code ‘54367’.” In one embodiment, the message is transmitted to a mobile phone of the account holder, which can reply to the message via short message service (SMS) to make the

purchase. In one embodiment, the account holder can also purchase the particular benefit offered by clicking on an “Activate” link provided in the message. The clicking brings the account holder to a page maintained by the web portal (143), where the details of the benefits can be explained and the benefit purchased. In one embodiment, the account holder can call the voice portal (143) of the system illustrated in **Figure 1** to make the purchase, via an IVR system, or a representative.

[00145] In one embodiment, the portal (143) and/or the notification engine (117) is to send approved transactions to the respective issuer processor (145), which then sends the data to the transaction handler (103) for fee billing to the account holders. In one embodiment, the portal (143) and/or the notification engine (117) is generate the approved transactions and use the transaction handler (103) process the account holder approved transactions.

[00146] In one embodiment, the portal (143) and/or the notification engine (117) is to record the account holder approved transactions in the data warehouse (149) to generate the feature usage data (121) to indicate that the particular benefits have been approved by the account holders.

[00147] In one embodiment, the details of benefits offered to account holders are stored in the data warehouse and are managed through a user interface within the system illustrated in **Figure 1**.

[00148] In one embodiment, an account holder can access the details of the benefits via the portal (143) using the point of interaction (107).

[00149] In one embodiment, an issuer (e.g., 131 or 132) or a feature provider (e.g., 118) can also access the relevant details of the benefits afforded according to the respective account features (e.g., 127, 128).

[00150] For example, in one embodiment, an issuer is to use the interface via the portal (143) to specify whether an account feature, such as “Sign and Travel Benefit Suite”, is to be funded by the operator of the transaction handler (103), the issuer, or the respective account holder.

[00151] In one embodiment, the issuer can use the portal (143) to specify the “Start Date” and “End Date” to define the benefits offer promotion period.

[00152] In one embodiment, the issuer can use the portal (143) to select a supplier, a service provider, and a broker, etc. for the fulfillment of the services or products offered as the benefit of the account features. In one embodiment, the procurement engine (119) generates the feature data (123) to provide valid candidates for selection by the issuer.

[00153] In one embodiment, the issuer may select a billing option from a list of candidates, such as per transaction, per statement, per phone call, per debit, per account, etc.

[00154] In one embodiment, the feature provider (118) is to communicate with the data warehouse (149) via the portal (143) to manage the features/benefits that have been assigned to and purchased by the account holders. The user interface for the feature provider (118) can be a web based user interface that can be accessed by the feature provider (118) through a communication network such as the Internet. Alternatively, a user interface can be provided to the feature provider (118) which is capable of accessing a relevant portion of the data warehouse (149). Through the user interface, the feature provider (118) can handle account holder inquiry as to whether a particular benefit has been assigned or purchased for that account holder and as to any fee dispute. In one embodiment, the user interface for the feature provider (118) includes a link, an icon button, or another user interface element, which when selected, provides a view of benefits usage history associated with an account feature (e.g., 127 or 128). The feature provider (118) may use the interface to initiate a refund for any particular fee charged. Similar user interfaces for accessing the usage details can also be provided to the issuer and/or the account holder via the portal (143).

[00155] **Figure 10** shows a method to provide the benefit of an account feature according to one embodiment. In **Figure 10**, the data warehouse (149) is to store (201) first data specifying a first feature set of a first account (e.g., 133), store (203) second data specifying a second feature set of a second account (e.g., 134) separate from the first account, and store (205) third data (e.g., 129) identifying a predetermined relation between account holders of the first account and the second account. The feature offer engine (113) is to provide (207) a benefit of a feature (128) in the second set, but not in the first set, to a user of the first account (133) based on the third data (e.g. 129).

[00156] In one embodiment, a computing apparatus for householding includes at least one of: the data warehouse (149), the feature offer engine (113), the notification engine (117), the procurement engine (119), the transaction handler (103), and the portal (143).

[00157] In one embodiment, the computing apparatus is to store account data (e.g., 133, 134) identifying account features (e.g., 127, 128) of a plurality of separate payment accounts, receive data identifying a first payment account (e.g., 133) which does not have an account feature (e.g., 128), identify at least one second payment account (e.g., 134) that is related to the first payment account (e.g., 133), and determine whether a user of the first payment account (e.g., 133) is eligible for a benefit of the account feature (e.g., 128) based on whether

the account data indicates that the at least one second payment account (e.g., 134) has the account feature (e.g., 128).

[00158] In one embodiment, the first payment account (e.g., 133) is linked to the at least one second payment account (e.g., 134) via householding link (e.g., 129) to indicate that the account holders of these accounts are in the same household or family. The benefit of the account feature includes one of: discount, incentive, reward, gift, access, insurance, service and cash back.

[00159] In one embodiment, the computing apparatus is to store link data (e.g., 129) to link the first payment account (e.g., 133) to the second payment account (134) in response to a request from an account holder and to store a set of rules (e.g., 125) to link accounts. The computing apparatus is to identify the at least one second payment account (e.g., 134) based on the link data and/or the rules.

[00160] For example, in one embodiment, the computing apparatus is to match information about the first payment account (e.g., 133) and information about the second payment account (e.g., 134) to determine whether the first payment account (e.g., 133) and the second payment account (e.g., 134) satisfy the set of rules (e.g., 125) to be linked.

[00161] In one embodiment, the computing apparatus is to receive feature selection data (as illustrated in **Figures 3 – 7**) for a third payment account having a feature set same as at least fourth payment account and to modify the account data in accordance with the feature selection data, to change feature specification of the third payment account without affecting feature specifications of the at least fourth payment account. The features specified for an individual account, instead of a group of accounts sharing a common portion of their account numbers.

[00162] In one embodiment, the feature selection data can be received from an entity such as an account holder of the third payment account, an issuer of the third payment account, or a representative of the issuer or transaction handler.

[00163] In one embodiment, householding is permitted when the first payment account (e.g., 133) and the second payment account (e.g., 134) are provided by a same issuer (e.g., when the account feature is sponsored by the issuer).

[00164] In one embodiment, householding is permitted when the first payment account (e.g., 133) and the second payment account (e.g., 134) are different (e.g., when the account feature is sponsored by the transaction handler (103), the account holder, and/or the feature provider (118) other than the issuers).

[00165] In one embodiment, householding is permitted when the first payment account (e.g., 133) and the second payment account (e.g., 134) are different. For example, the account feature (128) of the second payment account (134) is sponsored by the second issuer (e.g., 132); and when a transaction initiated using the first account (e.g., 133) is processed at the transaction handler (103) and determined to qualify for the feature (e.g., 128) through householding, the transaction handler (103) is to complete the transaction using the second payment account (e.g., 134).

[00166] In one embodiment, when a transaction initiated using the first account (e.g., 133) is processed at the transaction handler (103) and determined to qualify for the feature (e.g., 128) through householding, the transaction handler (103) is to complete the transaction using the first payment account (e.g., 133) and to charge a fee for the benefit to the second payment account (e.g., 134) (e.g., when the feature (e.g., 128) is funded by the account holder).

[00167] In one embodiment, the identifying of the at least one second payment account (e.g., 134) is in response to a transaction that was initiated using the first payment account (133) and that qualifies for the benefit of the account feature (e.g., 128).

[00168] In one embodiment, the benefit of the account feature (e.g., 128) includes a reward; and the benefit is accumulated under the first payment account (e.g., 133) separately from the second payment account (e.g., 134), even though the first payment account (e.g., 133) is eligible for the account feature (e.g., 128) only via the benefit of householding link (129) with the second payment account (e.g., 134). Alternatively, the benefit resulted from the transactions in the first payment account (e.g., 133) are accumulated in the second payment account (e.g., 134) when the benefit is provided based on the householding link (129) and the account feature (e.g., 128) of the second payment account (e.g., 134).

[00169] **Figure 11** shows a method to trigger a transaction according to one embodiment. In **Figure 11**, the data warehouse is to store (241) account data identifying features of accounts (e.g., 133, 134) and store (243) rules data (e.g., 125) identifying qualification requirements for transactions (e.g., 305) initiated in connection with account features (e.g., 127, 128). The feature offer engine (113) is to monitor (245) transactions (e.g., 301) in accordance with the rules data (e.g., 125) to detect a first transaction (e.g., 301) for initiation of a second transaction (e.g., 305). The notification engine (117) is to provide (247) an account holder with a real time notification of the second transaction (e.g., 305).

[00170] In one embodiment, a computing apparatus for triggering account feature related transactions includes at least one of: the data warehouse (149), the feature offer engine (113),

the notification engine (117), the procurement engine (119), the transaction handler (103), and the portal (143).

[00171] In one embodiment, the computing apparatus is to store account data identifying at least one account feature (127) of an account (133) to provide a benefit to an account holder of the account (133), store rules data (e.g., 125) identifying at least one qualification requirement associated with identification of transactions that qualify for the benefit of the account feature (127), monitor transactions (e.g., 301) in the account (133) using the rules data (e.g., 125) to identify a first transaction (301) that qualifies for the benefit of the account feature (127), and provide the account holder with a notification (311) of a second transaction (305) to be generated according to the account feature (127), prior to the generation of the second transaction (305).

[00172] In one embodiment, the computing apparatus is to further receive an approval (313) of the second transaction (305), prior to the generation of the second transaction (305).

[00173] In one embodiment, the second transaction (305) is to pay for a product or service afforded by the account feature (127); and the benefit may be a discount in a price of the product or service and/or a privilege to access the product or service.

[00174] In one embodiment, the notification (311) is provided in real time with authorization processing of the first transaction (301), or in response to settlement of the first transaction (301). In one embodiment, the notification (311) is provided via a text message to a mobile phone of the account holder, an email and/or a voice message.

[00175] In one embodiment, the computing apparatus is to identify a second account feature based on a third transaction in the account (133) and to offer, in real time with the processing of the third transaction, the account holder to purchase the second account feature. In one embodiment, the offer is provided via a notification via email, text message and/or voice message.

[00176] In one embodiment, the computing apparatus is to store transaction data (109) recording transactions in the account (133) and use the transaction data (109) to identify the second account feature. For example, in one embodiment, the computing apparatus is to determine a propensity score of the second account feature based on the transaction data and offer the second account feature when the propensity score is above a threshold. For example, in one embodiment, the computing apparatus is to determine an aggregated spending amount based on the transaction data and offer the second account feature when the aggregated spending amount is above a threshold. The aggregated spending amount is based on transactions of a particular type in the account in one embodiment, and based on all

transactions in a period of time regardless of the type of the transactions in another embodiment.

[00177] In one embodiment, the determination of whether or not to offer the second account feature to the respective account holder is further based on the aggregated spending profile of the account. In one embodiment, the transaction data (109) is used to determine the characteristics of transaction patterns of customers, which are profiled via clusters, factors, and/or categories of purchases. Details about aggregated spending profile and its use to target offers in one embodiment are provided in U.S. Pat. App. Ser. No. 12/777,173, filed May 10, 2010 and entitled "Systems and Methods to Summarize Transaction Data," the disclosure of which is hereby incorporated herein by reference.

[00178] In one embodiment, the computing apparatus is to receive from the account holder a confirmation to purchase the second account feature, charge the account a price for the second account feature, and update the account data to include the second account feature. In one embodiment, the account data is updated to include the second account feature without changing the account number of the account (133).

[00179] **Figure 12** shows a method to process a transaction according to one embodiment. In **Figure 12**, the computing apparatus is to store (231) data specifying different feature sets of a first account (e.g., 133) and a second account (e.g., 134) and data (129) linking the two accounts, receive (233) a transaction request identifying the first account (e.g., 133) and qualified for the benefit of an account feature (e.g., 128) present in the second account (e.g., 134) but not in the first account (e.g., 133), and process (235) the transaction request using the second account (e.g., 134) based on the data (129) linking the two accounts (e.g., 133 and 134).

[00180] **Figure 13** shows a method to adjust account features according to one embodiment. In **Figure 13**, the computing apparatus is to store (251) transaction data (109) of a plurality of accounts (e.g., 133, 134), determine (253) spending indicators of the accounts based on the transaction data, and to adjust (255) feature specifications of the accounts (e.g., 133, 134) based on the spending indicators, such as aggregated spending amount in a period of time, spending frequency or amount in a category or type, feature propensity score computed based on transaction data (109), etc.

TRANSACTION HANDLER

[00181] **Figure 14** shows a system to provide transaction based information according to one embodiment. In **Figure 14**, the transaction handler (103) is coupled between an issuer processor (145) and an acquirer processor (147) to facilitate authorization and settlement of transactions between a consumer account (146) and a merchant account (148). The transaction handler (103) records the transactions in the data warehouse (149). The portal (143) is coupled to the data warehouse (149) to provide information based on the transaction data (109), such as transaction triggers for benefit offers qualified under account features (e.g., 127, 128), loyalty triggers for the notifications of loyalty benefits. The portal (143) may be implemented as a web portal, a telephone gateway, a file/data server, etc.

[00182] In one embodiment, the transaction handler (103), the issuer processor (145) and the acquirer processor (147) are operated by different entities. In one embodiment, the transaction handler (103), the issuer processor (145) and the acquirer processor (147) are operated by the same entity.

[00183] In one embodiment, the portal (143) provides the account holders, the issuers (e.g., 131, 132), the feature providers (e.g., 118), etc. with the access to the feature related data in the data warehouse (149).

[00184] In **Figure 14**, the consumer account (146) is under the control of the issuer processor (145). The consumer account (146) may be owned by an individual, or an organization such as a business, a school, etc. The consumer account (146), such as account A (133) or account B (134) in **Figure 1**, may be a credit account, a debit account, or a stored value account. The issuer (e.g., 131 or 132) may provide the account holder with an account identification device (141) to identify the consumer account (146) using the account information (142), such as an account number. In some embodiments, the account holder may not be physically issued a card, or the account identification device (141); and the account holder may directly use/present the account information (142) for payment transaction without using the account identification device (141). The issuer processor (145) is to charge the consumer account (146) to pay for purchases.

[00185] In one embodiment, the account identification device (141) is a plastic card having a magnetic strip storing account information (142) identifying the consumer account (146) and/or the issuer processor (145). Alternatively, the account identification device (141) is a smartcard having an integrated circuit chip storing at least the account information (142). In one embodiment, the account identification device (141) includes an RFID device to

identify the account information (142). In one embodiment, the account identification device (141) includes a mobile phone having an integrated smartcard.

[00186] In one embodiment, the account information (142) is printed or embossed on the account identification device (141). The account information (142) may be printed as a bar code to allow the transaction terminal (105) to read the information via an optical scanner. The account information (142) may be stored in a memory of the account identification device (141) and configured to be read via wireless, contactless communications, such as near field communications via magnetic field coupling, infrared communications, or radio frequency communications. Alternatively, the transaction terminal (105) may require contact with the account identification device (141) to read the account information (142) (e.g., by reading the magnetic strip of a card with a magnetic strip reader).

[00187] In one embodiment, the transaction terminal (105) is configured to transmit an authorization request message to the acquirer processor (147). The authorization request includes the account information (142), an amount of payment, and information about the merchant (e.g., an indication of the merchant account (148)). The acquirer processor (147) requests the transaction handler (103) to process the authorization request, based on the account information (142) received in the transaction terminal (105). The transaction handler (103) routes the authorization request to the issuer processor (145) and may process and respond to the authorization request when the issuer processor (145) is not available. The issuer processor (145) determines whether to authorize the transaction based at least in part on a balance of the consumer account (146).

[00188] In one embodiment, the transaction handler (103), the issuer processor (145), and the acquirer processor (147) may each include a subsystem to identify the risk in the transaction and may reject the transaction based on the risk assessment.

[00189] In one embodiment, the account identification device (141) includes security features to prevent unauthorized uses of the consumer account (146), such as a logo to show the authenticity of the account identification device (141), encryption to protect the account information (142), etc.

[00190] In one embodiment, the transaction terminal (105) is configured to interact with the account identification device (141) to obtain the account information (142) that identifies the consumer account (146) and/or the issuer processor (145). The transaction terminal (105) communicates with the acquirer processor (147) that controls the merchant account (148) of a merchant. The transaction terminal (105) may communicate with the acquirer processor (147) via a data communication connection, such as a telephone connection, an Internet

connection, etc. The acquirer processor (147) is to collect payments into the merchant account (148) on behalf of the merchant.

[00191] In one embodiment, the transaction terminal (105) is a POS terminal at a traditional, offline, “brick and mortar” retail store. In another embodiment, the transaction terminal (105) is an online server that receives account information (142) of the consumer account (146) from the account holder through a web connection. In one embodiment, the account holder may provide account information (142) through a telephone call, via verbal communications with a representative of the merchant; and the representative enters the account information (142) into the transaction terminal (105) to initiate the transaction.

[00192] In one embodiment, the account information (142) can be entered directly into the transaction terminal (105) to make payment from the consumer account (146), without having to physically present the account identification device (141). When a transaction is initiated without physically presenting an account identification device (141), the transaction is classified as a “card-not-present” (CNP) transaction.

[00193] In one embodiment, the issuer processor (145) may control more than one consumer account (146); the acquirer processor (147) may control more than one merchant account (148); and the transaction handler (103) is connected between a plurality of issuer processors (e.g., 145) and a plurality of acquirer processors (e.g., 147). An entity (e.g., bank) may operate both an issuer processor (145) and an acquirer processor (147).

[00194] In one embodiment, the transaction handler (103), the issuer processor (145), the acquirer processor (147), the transaction terminal (105), the portal (143), and other devices and/or services accessing the portal (143) are connected via a network (101), which may include one or more communications networks, such as local area networks, cellular telecommunications networks, wireless wide area networks, wireless local area networks, an intranet, and Internet. In one embodiment, dedicated communication channels are used between the transaction handler (103) and the issuer processor (145), between the transaction handler (103) and the acquirer processor (147), and/or between the portal (143) and the transaction handler (103).

[00195] In one embodiment, the transaction handler (103) uses the data warehouse (149) to store the records about the transactions, such as the transaction data (109). In one embodiment, the transaction handler (103) includes a powerful computer, or cluster of computers functioning as a unit, controlled by instructions stored on a computer readable medium.

[00196] In one embodiment, the transaction handler (103) is configured to support and deliver authorization services, exception file services, and clearing and settlement services. In one embodiment, the transaction handler (103) has a subsystem to process authorization requests and another subsystem to perform clearing and settlement services.

[00197] In one embodiment, the transaction handler (103) is configured to process different types of transactions, such credit card transactions, debit card transactions, prepaid card transactions, and other types of commercial transactions.

[00198] In one embodiment, the transaction handler (103) facilitates the communications between the issuer processor (145) and the acquirer processor (147).

[00199] In one embodiment, the transaction terminal (105) is configured to submit the authorized transactions to the acquirer processor (147) for settlement. The amount for the settlement may be different from the amount specified in the authorization request. The transaction handler (103) is coupled between the issuer processor (145) and the acquirer processor (147) to facilitate the clearing and settling of the transaction. Clearing includes the exchange of financial information between the issuer processor (145) and the acquirer processor (147); and settlement includes the exchange of funds.

[00200] In one embodiment, the issuer processor (145) is to provide funds to make payments on behalf of the consumer account (146). The acquirer processor (147) is to receive the funds on behalf of the merchant account (148). The issuer processor (145) and the acquirer processor (147) communicate with the transaction handler (103) to coordinate the transfer of funds for the transaction. In one embodiment, the funds are transferred electronically.

[00201] In one embodiment, the transaction terminal (105) may submit a transaction directly for settlement, without having to separately submit an authorization request.

[00202] In one embodiment, the portal (143) provides a user interface to allow the account holder to organize the transactions in one or more consumer accounts (146) of the user with one or more issuers. The account holder may organize the transactions using information and/or categories identified in the transaction records, such as merchant category, transaction date, amount, etc. Examples and techniques in one embodiment are provided in U.S. Pat. App. Ser. No. 11/378,215, filed Mar. 16, 2006, assigned Pub. No. 2007/0055597, and entitled "Method and System for Manipulating Purchase Information," the disclosure of which is hereby incorporated herein by reference.

[00203] In one embodiment, the portal (143) provides transaction based statistics, such as indicators for retail spending monitoring, indicators for merchant benchmarking,

industry/market segmentation, indicators of spending patterns, etc. Further examples can be found in U.S. Pat. App. Ser. No. 12/191,796, filed Aug. 14, 2008, assigned Pub. No. 2009/0048884, and entitled "Merchant Benchmarking Tool," the disclosure of which application are hereby incorporated herein by reference.

TRANSACTION TERMINAL

[00204] **Figure 15** illustrates a transaction terminal according to one embodiment. In **Figure 15**, the transaction terminal (105) is configured to interact with an account identification device (141) to obtain account information (142) about the consumer account (146).

[00205] In one embodiment, the transaction terminal (105) includes a memory (167) coupled to the processor (151), which controls the operations of a reader (163), an input device (153), an output device (165) and a network interface (161). The memory (167) may store instructions for the processor (151) and/or data, such as an identification that is associated with the merchant account (148).

[00206] In one embodiment, the reader (163) includes a magnetic strip reader. In another embodiment, the reader (163) includes a contactless reader, such as a radio frequency identification (RFID) reader, a near field communications (NFC) device configured to read data via magnetic field coupling (in accordance with ISO standard 14443/NFC), a Bluetooth transceiver, a WiFi transceiver, an infrared transceiver, a laser scanner, etc.

[00207] In one embodiment, the input device (153) includes key buttons that can be used to enter the account information (142) directly into the transaction terminal (105) without the physical presence of the account identification device (141). The input device (153) can be configured to provide further information to initiate a transaction, such as a personal identification number (PIN), password, zip code, etc. that may be used to access the account identification device (141), or in combination with the account information (142) obtained from the account identification device (141).

[00208] In one embodiment, the output device (165) may include a display, a speaker, and/or a printer to present information, such as the result of an authorization request, a receipt for the transaction, an advertisement, etc.

[00209] In one embodiment, the network interface (161) is configured to communicate with the acquirer processor (147) via a telephone connection, an Internet connection, or a dedicated data communication channel.

[00210] In one embodiment, the instructions stored in the memory (167) are configured at least to cause the transaction terminal (105) to send an authorization request message to the acquirer processor (147) to initiate a transaction. The transaction terminal (105) may or may not send a separate request for the clearing and settling of the transaction. The instructions stored in the memory (167) are also configured to cause the transaction terminal (105) to perform other types of functions discussed in this description.

[00211] In one embodiment, a transaction terminal (105) may have fewer components than those illustrated in **Figure 15**. For example, in one embodiment, the transaction terminal (105) is configured for “card-not-present” transactions; and the transaction terminal (105) does not have a reader (163).

[00212] In one embodiment, a transaction terminal (105) may have more components than those illustrated in **Figure 15**. For example, in one embodiment, the transaction terminal (105) is an ATM machine, which includes components to dispense cash under certain conditions.

ACCOUNT IDENTIFICATION DEVICE

[00213] **Figure 16** illustrates an account identifying device according to one embodiment. In **Figure 16**, the account identification device (141) is configured to carry account information (142) that identifies the consumer account (146).

[00214] In one embodiment, the account identification device (141) includes a memory (167) coupled to the processor (151), which controls the operations of a communication device (159), an input device (153), an audio device (157) and a display device (155). The memory (167) may store instructions for the processor (151) and/or data, such as the account information (142) associated with the consumer account (146).

[00215] In one embodiment, the account information (142) includes an identifier identifying the issuer (and thus the issuer processor (145)) among a plurality of issuers, and an identifier identifying the consumer account among a plurality of consumer accounts controlled by the issuer processor (145). The account information (142) may include an expiration date of the account identification device (141), the name of the consumer holding the consumer account (146), and/or an identifier identifying the account identification device (141) among a plurality of account identification devices associated with the consumer account (146).

[00216] In one embodiment, the account information (142) may further include a loyalty program account number, accumulated rewards of the consumer in the loyalty program, an address of the consumer, a balance of the consumer account (146), transit information (e.g., a subway or train pass), access information (e.g., access badges), and/or consumer information (e.g., name, date of birth), etc.

[00217] In one embodiment, the memory includes a nonvolatile memory, such as magnetic strip, a memory chip, a flash memory, a Read Only Memory (ROM), etc. to store the account information (142).

[00218] In one embodiment, the information stored in the memory (167) of the account identification device (141) may also be in the form of data tracks that are traditionally associated with credits cards. Such tracks include Track 1 and Track 2. Track 1 (“International Air Transport Association”) stores more information than Track 2, and contains the account holder’s name as well as the account number and other discretionary data. Track 1 is sometimes used by airlines when securing reservations with a credit card. Track 2 (“American Banking Association”) is currently most commonly used and is read by ATMs and credit card checkers. The ABA (American Banking Association) designed the specifications of Track 1 and banks abide by it. It contains the account holder’s account number, encrypted PIN, and other discretionary data.

[00219] In one embodiment, the communication device (159) includes a semiconductor chip to implement a transceiver for communication with the reader (163) and an antenna to provide and/or receive wireless signals.

[00220] In one embodiment, the communication device (159) is configured to communicate with the reader (163). The communication device (159) may include a transmitter to transmit the account information (142) via wireless transmissions, such as radio frequency signals, magnetic coupling, or infrared, Bluetooth or WiFi signals, etc.

[00221] In one embodiment, the account identification device (141) is in the form of a mobile phone, personal digital assistant (PDA), etc. The input device (153) can be used to provide input to the processor (151) to control the operation of the account identification device (141); and the audio device (157) and the display device (155) may present status information and/or other information, such as advertisements or offers. The account identification device (141) may include further components that are not shown in **Figure 16**, such as a cellular communications subsystem.

[00222] In one embodiment, the communication device (159) may access the account information (142) stored on the memory (167) without going through the processor (151).

[00223] In one embodiment, the account identification device (141) has fewer components than those illustrated in **Figure 16**. For example, an account identification device (141) does not have the input device (153), the audio device (157) and the display device (155) in one embodiment; and in another embodiment, an account identification device (141) does not have components (151-159).

[00224] For example, in one embodiment, an account identification device (141) is in the form of a debit card, a credit card, a smartcard, or a consumer device that has optional features such as magnetic strips, or smartcards.

[00225] An example of an account identification device (141) is a magnetic strip attached to a plastic substrate in the form of a card. The magnetic strip is used as the memory (167) of the account identification device (141) to provide the account information (142). Consumer information, such as account number, expiration date, and consumer name may be printed or embossed on the card. A semiconductor chip implementing the memory (167) and the communication device (159) may also be embedded in the plastic card to provide account information (142) in one embodiment. In one embodiment, the account identification device (141) has the semiconductor chip but not the magnetic strip.

[00226] In one embodiment, the account identification device (141) is integrated with a security device, such as an access card, a radio frequency identification (RFID) tag, a security card, a transponder, etc.

[00227] In one embodiment, the account identification device (141) is a handheld and compact device. In one embodiment, the account identification device (141) has a size suitable to be placed in a wallet or pocket of the consumer.

[00228] Some examples of an account identification device (141) include a credit card, a debit card, a stored value device, a payment card, a gift card, a smartcard, a smart media card, a payroll card, a health care card, a wrist band, a keychain device, a supermarket discount card, a transponder, and a machine readable medium containing account information (142).

POINT OF INTERACTION

[00229] In one embodiment, the point of interaction (107) is to provide an offer to the account holder, and/or to provide a user interface to customize, use, and access account features (e.g., 127 and 128).

[00230] In one embodiment, the point of interaction (107) is to facilitate a marketing interaction which may include an announcement and/or an offer of a benefit, such as a

discount, incentive, reward, coupon, gift, cash back, or opportunity (e.g., special ticket/admission).

[00231] In one embodiment, the marketing interaction is provided as a notification of a benefit of an account feature (e.g., 127 or 128). The benefit may be triggered by a qualifying transaction, or other events, such as an anniversary date, the current location of the account holder, etc.

[00232] In one embodiment, the marketing interaction is provided as a notification of the eligibility for an account feature (e.g., 127 or 128). The eligibility may be triggered by a qualifying transaction, an aggregated spending amount in a period of time, an aggregated spending amount in a category, or other events, such as an anniversary date, the current location of the account holder, etc.

[00233] In one embodiment, the notification may include an offer of a product or service, an announcement of a product or service, or a presentation of a brand of products or services, or a notice of events, facts, opinions, etc. The notification can be presented in text, graphics, audio, video, or animation, and as printed matter, web content, interactive media, etc. In one embodiment, the notification is provided in a form of an advertisement.

[00234] In one embodiment, the notification is presented in response to the presence of an account identification device (141), or in response to an account identification device (141) being used to make a financial transaction, or in response to other user activities, such as browsing a web page, submitting a search request, communicating online, entering a wireless communication zone, etc. In one embodiment, the presentation of notification may be not a result of a user action.

[00235] In one embodiment, the point of interaction (107) can be one of various endpoints of the transaction network, such as point of sale (POS) terminals, automated teller machines (ATMs), electronic kiosks (or computer kiosks or interactive kiosks), self-assist checkout terminals, vending machines, gas pumps, websites of banks (e.g., issuer banks or acquirer banks of credit cards), bank statements (e.g., credit card statements), websites of the transaction handler (103), websites of merchants, checkout websites or web pages for online purchases, etc.

[00236] In one embodiment, the point of interaction (107) may be the same as the transaction terminal (105), such as a point of sale (POS) terminal, an automated teller machine (ATM), a mobile phone, a computer of the user for an online transaction, etc. In one embodiment, the point of interaction (107) may be co-located with the transaction terminal (105), or produced by the transaction terminal (e.g., a receipt produced by the transaction

terminal (105)). In one embodiment, the point of interaction (107) may be separate from and not co-located with the transaction terminal (105), such as a mobile phone, a personal digital assistant, a personal computer of the user, a voice mail box of the user, an email inbox of the user, a digital signage, etc.

[00237] For example, the advertisements can be presented on a portion of media for a transaction with the customer, which portion might otherwise be unused and thus referred to as a “white space” herein. A white space can be on a printed matter (e.g., a receipt printed for the transaction, or a printed credit card statement), on a video display (e.g., a display monitor of a POS terminal for a retail transaction, an ATM for cash withdrawal or money transfer, a personal computer of the customer for online purchases), or on an audio channel (e.g., an interactive voice response (IVR) system for a transaction over a telephonic device).

[00238] In one embodiment, the white space is part of a media channel available to present a message from the transaction handler (103) in connection with the processing of a transaction of the account holder. In one embodiment, the white space is in a media channel that is used to report information about a transaction of the account holder, such as an authorization status, a confirmation message, a verification message, a user interface to verify a password for the online use of the account information (142), a monthly statement, an alert or a report, or a web page provided by the portal (143) to access a loyalty program associated with the consumer account (146) or a registration program.

[00239] In other embodiments, the advertisements can also be presented via other media channels which may not involve a transaction processed by the transaction handler (103). For example, the advertisements can be presented on publications or announcements (e.g., newspapers, magazines, books, directories, radio broadcasts, television, digital signage, etc., which may be in an electronic form, or in a printed or painted form). The advertisements may be presented on paper, on websites, on billboards, or on audio portals.

[00240] In one embodiment, the transaction handler (103) purchases the rights to use the media channels from the owner or operators of the media channels and uses the media channels as advertisement spaces. For example, white spaces at a point of interaction (e.g., 107) with customers for transactions processed by the transaction handler (103) can be used to deliver advertisements relevant to the customers conducting the transactions; and the advertisement can be selected based at least in part on the intelligence information derived from the accumulated transaction data (109) and/or the context at the point of interaction (107) and/or the transaction terminal (105).

[00241] In general, a point of interaction (e.g., 107) may or may not be capable of receiving inputs from the customers, and may or may not co-located with a transaction terminal (e.g., 105) that initiates the transactions. The white spaces for presenting the advertisement on the point of interaction (107) may be on a portion of a geographical display space (e.g., on a screen), or on a temporal space (e.g., in an audio stream).

[00242] In one embodiment, the point of interaction (107) may be used to primarily to access services not provided by the transaction handler (103), such as services provided by a search engine, a social networking website, an online marketplace, a blog, a news site, a television program provider, a radio station, a satellite, a publisher, etc.

[00243] In one embodiment, a consumer device is used as the point of interaction (107), which may be a non-portable consumer device or a portable computing device. The consumer device is to provide media content to the account holder and may receive input from the account holder.

[00244] Examples of non-portable consumer devices include a computer terminal, a television set, a personal computer, a set-top box, or the like. Examples of portable consumer devices include a portable computer, a cellular phone, a personal digital assistant (PDA), a pager, a security card, a wireless terminal, or the like. The consumer device may be implemented as a data processing system as illustrated in **Figure 17**, with more or fewer components.

[00245] In one embodiment, the consumer device includes an account identification device (141). For example, a smart card used as an account identification device (141) is integrated with a mobile phone, or a personal digital assistant (PDA).

[00246] In one embodiment, the point of interaction (107) is integrated with a transaction terminal (105). For example, a self-service checkout terminal includes a touch pad to interact with the account holder; and an ATM machine includes a user interface subsystem to interact with the account holder.

HARDWARE

[00247] In one embodiment, a computing apparatus is configured to include some of the modules or components illustrated in **Figures 1, 2 and 14**, such as the transaction handler (103), the portal (143), the issuer processor (145), the acquirer processor (147), the feature offer engine (113), the notification engine (117), the procurement engine (119), and their associated storage devices, such as the data warehouse (149).

[00248] In one embodiment, at least some of the modules or components illustrated in **Figures 1, 2 and 14**, such as the transaction handler (103), the transaction terminal (105), the point of interaction (107), the portal (143), the issuer processor (145), the acquirer processor (147), the feature offer engine (113), the notification engine (117), the procurement engine (119), and the account identification device (141), can be implemented as a computer system, such as a data processing system illustrated in **Figure 17**, with more or fewer components. Some of the modules may share hardware or be combined on a computer system. In one embodiment, a network of computers can be used to implement one or more of the modules.

[00249] Further, the data illustrated in **Figure 1**, such as transaction data (109), feature data (123), feature rules (125), and feature usage data (121) can be stored in storage devices of one or more computers accessible to the corresponding modules or components illustrated in **Figure 1**. For example, the transaction data (109) can be stored in the data warehouse (149) that can be implemented as a data processing system illustrated in **Figure 17**, with more or fewer components.

[00250] In one embodiment, the transaction handler (103) is a payment processing system, or a payment card processor, such as a card processor for credit cards, debit cards, etc.

[00251] **Figure 17** illustrates a data processing system according to one embodiment. While **Figure 17** illustrates various components of a computer system, it is not intended to represent any particular architecture or manner of interconnecting the components. One embodiment may use other systems that have fewer or more components than those shown in **Figure 17**.

[00252] In **Figure 17**, the data processing system (170) includes an inter-connect (171) (e.g., bus and system core logic), which interconnects a microprocessor(s) (173) and memory (167). The microprocessor (173) is coupled to cache memory (179) in the example of **Figure 17**.

[00253] In one embodiment, the inter-connect (171) interconnects the microprocessor(s) (173) and the memory (167) together and also interconnects them to input/output (I/O) device(s) (175) via I/O controller(s) (177). I/O devices (175) may include a display device and/or peripheral devices, such as mice, keyboards, modems, network interfaces, printers, scanners, video cameras and other devices known in the art. In one embodiment, when the data processing system is a server system, some of the I/O devices (175), such as printers, scanners, mice, and/or keyboards, are optional.

[00254] In one embodiment, the inter-connect (171) includes one or more buses connected to one another through various bridges, controllers and/or adapters. In one embodiment the

I/O controllers (177) include a USB (Universal Serial Bus) adapter for controlling USB peripherals, and/or an IEEE-1394 bus adapter for controlling IEEE-1394 peripherals.

[00255] In one embodiment, the memory (167) includes one or more of: ROM (Read Only Memory), volatile RAM (Random Access Memory), and non-volatile memory, such as hard drive, flash memory, etc.

[00256] Volatile RAM is typically implemented as dynamic RAM (DRAM) which requires power continually in order to refresh or maintain the data in the memory. Non-volatile memory is typically a magnetic hard drive, a magnetic optical drive, an optical drive (e.g., a DVD RAM), or other type of memory system which maintains data even after power is removed from the system. The non-volatile memory may also be a random access memory.

[00257] The non-volatile memory can be a local device coupled directly to the rest of the components in the data processing system. A non-volatile memory that is remote from the system, such as a network storage device coupled to the data processing system through a network interface such as a modem or Ethernet interface, can also be used.

[00258] In this description, some functions and operations are described as being performed by or caused by software code to simplify description. However, such expressions are also used to specify that the functions result from execution of the code/instructions by a processor, such as a microprocessor.

[00259] Alternatively, or in combination, the functions and operations as described here can be implemented using special purpose circuitry, with or without software instructions, such as using Application-Specific Integrated Circuit (ASIC) or Field-Programmable Gate Array (FPGA). Embodiments can be implemented using hardwired circuitry without software instructions, or in combination with software instructions. Thus, the techniques are limited neither to any specific combination of hardware circuitry and software, nor to any particular source for the instructions executed by the data processing system.

[00260] While one embodiment can be implemented in fully functioning computers and computer systems, various embodiments are capable of being distributed as a computing product in a variety of forms and are capable of being applied regardless of the particular type of machine or computer-readable media used to actually effect the distribution.

[00261] At least some aspects disclosed can be embodied, at least in part, in software. That is, the techniques may be carried out in a computer system or other data processing system in response to its processor, such as a microprocessor, executing sequences of

instructions contained in a memory, such as ROM, volatile RAM, non-volatile memory, cache or a remote storage device.

[00262] Routines executed to implement the embodiments may be implemented as part of an operating system or a specific application, component, program, object, module or sequence of instructions referred to as “computer programs.” The computer programs typically include one or more instructions set at various times in various memory and storage devices in a computer, and that, when read and executed by one or more processors in a computer, cause the computer to perform operations necessary to execute elements involving the various aspects.

[00263] A machine readable medium can be used to store software and data which when executed by a data processing system causes the system to perform various methods. The executable software and data may be stored in various places including for example ROM, volatile RAM, non-volatile memory and/or cache. Portions of this software and/or data may be stored in any one of these storage devices. Further, the data and instructions can be obtained from centralized servers or peer to peer networks. Different portions of the data and instructions can be obtained from different centralized servers and/or peer to peer networks at different times and in different communication sessions or in a same communication session. The data and instructions can be obtained in entirety prior to the execution of the applications. Alternatively, portions of the data and instructions can be obtained dynamically, just in time, when needed for execution. Thus, it is not required that the data and instructions be on a machine readable medium in entirety at a particular instance of time.

[00264] Examples of computer-readable media include but are not limited to recordable and non-recordable type media such as volatile and non-volatile memory devices, read only memory (ROM), random access memory (RAM), flash memory devices, floppy and other removable disks, magnetic disk storage media, optical storage media (e.g., Compact Disk Read-Only Memory (CD ROMS), Digital Versatile Disks (DVDs), etc.), among others. The computer-readable media may store the instructions.

[00265] The instructions may also be embodied in digital and analog communication links for electrical, optical, acoustical or other forms of propagated signals, such as carrier waves, infrared signals, digital signals, etc. However, propagated signals, such as carrier waves, infrared signals, digital signals, etc. are not tangible machine readable medium and are not configured to store instructions.

[00266] In general, a machine readable medium includes any mechanism that provides (i.e., stores and/or transmits) information in a form accessible by a machine (e.g., a computer,

network device, personal digital assistant, manufacturing tool, any device with a set of one or more processors, etc.).

[00267] In various embodiments, hardwired circuitry may be used in combination with software instructions to implement the techniques. Thus, the techniques are neither limited to any specific combination of hardware circuitry and software nor to any particular source for the instructions executed by the data processing system.

OTHER ASPECTS

[00268] The description and drawings are illustrative and are not to be construed as limiting. Numerous specific details are described to provide a thorough understanding. However, in certain instances, well known or conventional details are not described in order to avoid obscuring the description. References to one or an embodiment in the present disclosure are not necessarily references to the same embodiment; and, such references mean at least one.

[00269] The use of headings herein is merely provided for ease of reference, and shall not be interpreted in any way to limit this disclosure or the following claims.

[00270] Reference to “one embodiment” or “an embodiment” means that a particular feature, structure, or characteristic described in connection with the embodiment is included in at least one embodiment of the disclosure. The appearances of the phrase “in one embodiment” in various places in the specification are not necessarily all referring to the same embodiment, and are not necessarily all referring to separate or alternative embodiments mutually exclusive of other embodiments. Moreover, various features are described which may be exhibited by one embodiment and not by others. Similarly, various requirements are described which may be requirements for one embodiment but not other embodiments. Unless excluded by explicit description and/or apparent incompatibility, any combination of various features described in this description is also included here.

[00271] In the foregoing specification, the disclosure has been described with reference to specific exemplary embodiments thereof. It will be evident that various modifications may be made thereto without departing from the broader spirit and scope as set forth in the following claims. The specification and drawings are, accordingly, to be regarded in an illustrative sense rather than a restrictive sense.

CLAIMS

What is claimed is:

1. A computer-implemented method, comprising:
storing account data identifying account features of a plurality of separate payment accounts;
receiving, in a computing apparatus, data identifying a first payment account, wherein the account data indicates that the first payment account does not have an account feature;
identifying, by the computing apparatus, at least one second payment account that is related to the first payment account; and
determining, by the computing apparatus, whether a user of the first payment account is eligible for a benefit of the account feature based on whether the account data indicates that the at least one second payment account has the account feature.
2. The method of claim 1, wherein the benefit of the account feature comprises one of: discount, incentive, reward, gift, access, insurance, service and cash back.
3. The method of claim 1, further comprising:
storing link data to link the first payment account to the second payment account in response to a request from an account holder, wherein the identifying is based on the link data.
4. The method of claim 1, further comprising:
storing a set of rules to link accounts, wherein the identifying is based on the set of rules.
5. The method of claim 4, further comprising:
matching information about the first payment account and information about the second payment account to determine whether the first payment account and the second payment account satisfy the set of rules to be linked.

6. The method of claim 4, wherein the first payment account and the second payment account are linked based on a determination of a family relationship between account holders of the first payment account and the second payment account.
7. The method of claim 6, wherein the first payment account and the second payment account are linked based on a determination that the account holders are in a same household.
8. The method of claim 1, further comprising:
receiving, in the computing apparatus, feature selection data for a third payment account having a feature set same as at least fourth payment account; and
modifying, by the computing apparatus, the account data in accordance with the feature selection data, to change feature specification of the third payment account without affecting feature specifications of the at least fourth payment account.
9. The method of claim 8, wherein the feature selection data is received from an entity selected from the group consisting of: an account holder of the third payment account and an issuer of the third payment account.
10. The method of claim 1, wherein the first payment account and the second payment account are provided by a same issuer.
11. The method of claim 1, wherein the first payment account is provided by a first issuer and the second payment account is provided by a second issuer different from the first issuer.
12. The method of claim 11, wherein the account feature of the second payment account is sponsored by the second issuer.
13. The method of claim 12, wherein the identifying is in response to a transaction that qualifies for the benefit of the account feature.

14. The method of claim 12, wherein the data identifying the first payment account comprises a request for the transaction; and the method further comprises: completing the transaction using the second payment account.
15. The method of claim 11, wherein the data identifying the first payment account comprises a request for the transaction; and the method further comprises: completing the transaction using the first payment account; and charging a fee for the benefit to the second payment account.
16. The method of claim 1, wherein the benefit comprises a reward; and the benefit is accumulated under the first payment account separately from the second payment account.
17. The method of claim 1, wherein the identifying is in response to a transaction being processed in a transaction handler to make a payment from an issuer to an acquirer in response to an identifier of the first payment account, as issued by the issuer to the user, being submitted by a merchant to the acquirer, the issuer to make the payment on behalf of the user, the acquirer to receive the payment on behalf of the merchant; and the account feature of the second payment account is sponsored by the transaction handler.
18. A computer storage medium storing instructions which, when executed on a computing apparatus, cause the computing apparatus to perform a method, the method comprising:
 - storing account data identifying account features of a plurality of separate payment accounts;
 - receiving data identifying a first payment account, wherein the account data indicates that the first payment account does not have an account feature;
 - identifying at least one second payment account that is related to the first payment account; and
 - determining whether a user of the first payment account is eligible for a benefit of the account feature based on whether the account data indicates that the at least one second payment account has the account feature.

19. A system, comprising:
a transaction handler to process transactions, each of the transactions being processed to make a payment from an issuer to an acquirer via the transaction handler in response to an account identifier of a customer, as issued by the issuer, submitted by a merchant to the acquirer, the issuer to make the payment on behalf of the customer, the acquirer to receive the payment on behalf of the merchant;
a data warehouse to store transaction data recording the transactions processed at the transaction handler, account data identifying account features of a plurality of separate accounts, including a first account that does not have an account feature and a second account that has the account feature, wherein account holders of the first account and the second account are in a same household,
a set of rules; and
a portal to receive a request identifying the first account and to determine whether a transaction initiated in the first account and qualified for a benefit of the account feature is entitled to the benefit based on the set of rules.
20. The system of claim 1, further comprising:
a notification engine to transmit a message to an account holder of the first account when the portal determines that the transaction is entitled to the benefit.
21. A computer-implemented method, comprising:
storing account data identifying at least one account feature of an account, the account feature to provide a benefit to an account holder of the account;
storing rules data identifying at least one qualification requirement associated with identification of transactions that qualify for the benefit of the account feature;
monitoring, by a computing apparatus, transactions in the account using the rules data;
identifying, by the computing apparatus and based on the monitoring, a first transaction that qualifies for the benefit of the account feature; and

- providing, by the computing apparatus, the account holder with a notification of a second transaction to be generated according to the account feature, prior to generation of the second transaction.
22. The method of claim 21, further comprising:
receiving, by the computing apparatus, an approval of the second transaction, prior to the generation of the second transaction.
23. The method of claim 22, wherein the second transaction is to pay for a product or service afforded by the account feature.
24. The method of claim 23, wherein the benefit comprises a discount in a price of the product or service; and the method further comprises:
detecting, by the computing apparatus, the second transaction processed by a transaction handler; and
providing, by the computing apparatus, the benefit via statement credit initiated by the transaction handler.
25. The method of claim 23, wherein the benefit comprises a privilege to access the product or service.
26. The method of claim 21, wherein the notification is provided in real time with authorization processing of the first transaction.
27. The method of claim 21, wherein the notification is provided in response to settlement of the first transaction.
28. The method of claim 21, wherein the notification is via one of: a text message to a mobile phone of the account holder, an email and a voice message.
29. The method of claim 21, further comprising:
identifying a second account feature based on a third transaction in the account;

- offering, by the computing apparatus, the account holder to purchase the second account feature.
30. The method of claim 29, wherein the offering is in real time with processing of the third transaction.
31. The method of claim 29, further comprising:
storing transaction data recording transactions in the account;
wherein the second account feature is identified based at least in part on the transaction data.
32. The method of claim 31, further comprising:
determining a propensity score of the second account feature based on the transaction data;
wherein the second account feature is offered when the propensity score is above a threshold.
33. The method of claim 31, further comprising:
determining an aggregated spending amount based on the transaction data; and
wherein the second account feature is offered when the aggregated spending amount is above a threshold.
34. The method of claim 33, wherein the aggregated spending amount is based on transactions of a particular type in the account.
35. The method of claim 29, wherein the offering includes a notification in one of: email, text message and voice message.
36. The method of claim 35, further comprising:
receiving from the account holder a confirmation to purchase the second account feature;
charging the account a price for the second account feature; and
updating the account data to include the second account feature.

37. The method of claim 36, wherein the account data is updated to include the second account feature without changing an account number of the account.
38. A computer storage medium storing instructions which, when executed on a computing apparatus, cause the computing apparatus to perform a method, the method comprising:
storing account data identifying at least one account feature of an account, the account feature to provide a benefit to an account holder of the account;
storing rules data identifying at least one qualification requirement;
monitoring transactions in the account using the rules data;
identifying a first transaction based on the monitoring; and
providing the account holder with an offer associated with a first account feature in response to the identifying of the first transaction in real time with processing of the first transaction.
39. A system, comprising:
a transaction handler to process transactions, each of the transactions being processed to make a payment from an issuer to an acquirer via the transaction handler in response to an account identifier of a customer, as issued by the issuer, submitted by a merchant to the acquirer, the issuer to make the payment on behalf of the customer, the acquirer to receive the payment on behalf of the merchant;
a data warehouse coupled to the transaction handler, the data warehouse to store transaction data recording the transactions processed at the transaction handler, account data identifying at least one account feature of an account, the account feature to provide a benefit to an account holder of the account, and rules data identifying at least one qualification requirement;
a feature offer engine coupled to the data warehouse to use the rules data to monitor the transactions in the account to identify a first transaction; and
a notification engine coupled to the feature offer engine to provide the account holder with an offer associated with a first account feature in real time with processing of the first transaction.

40. The system of claim 39, further comprising:
a portal coupled to the transaction handler to receive an approval of a second transaction in accordance with the offer;
wherein the transaction handler is to process the second transaction to pay for a purchase identified in the offer.

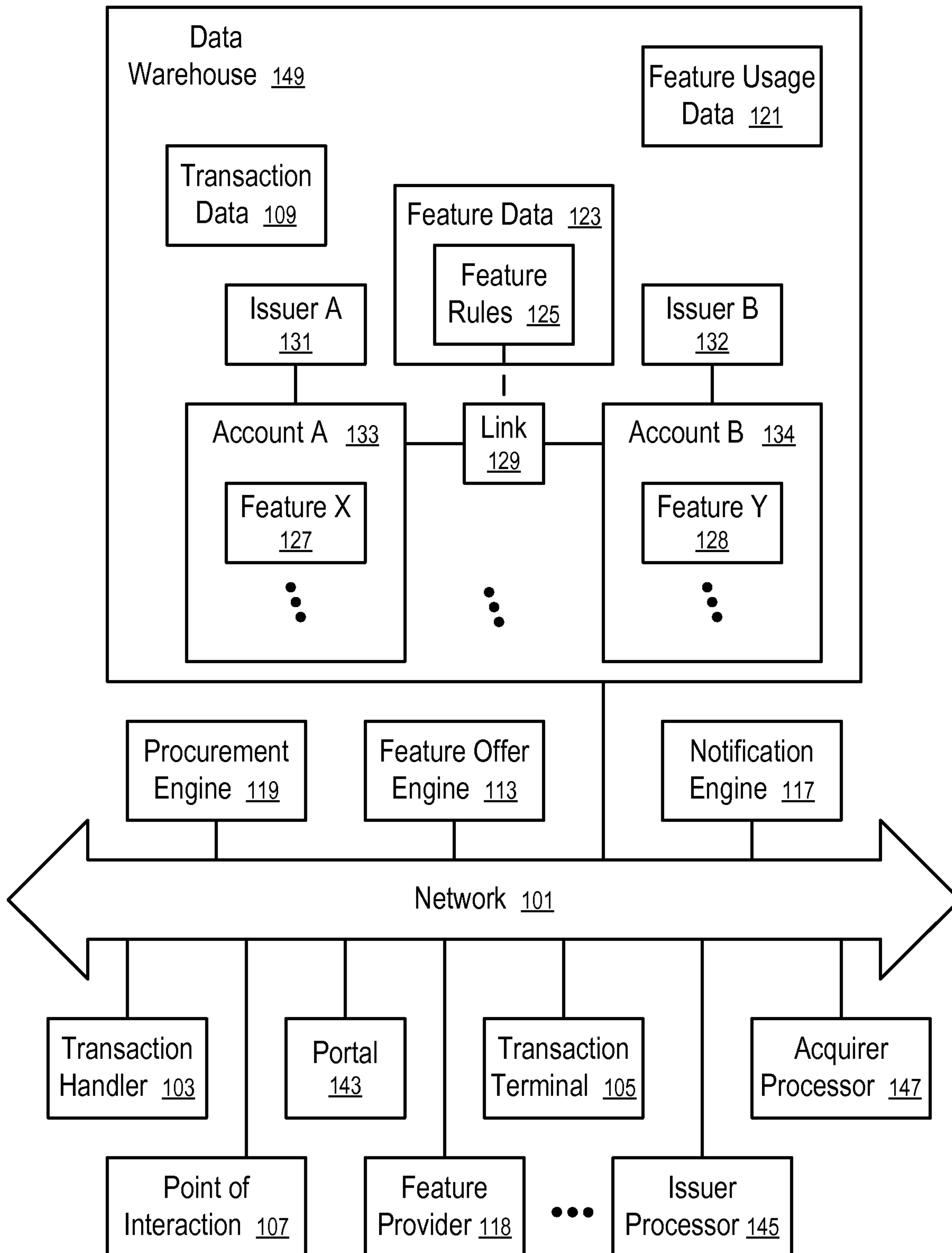

FIG. 1

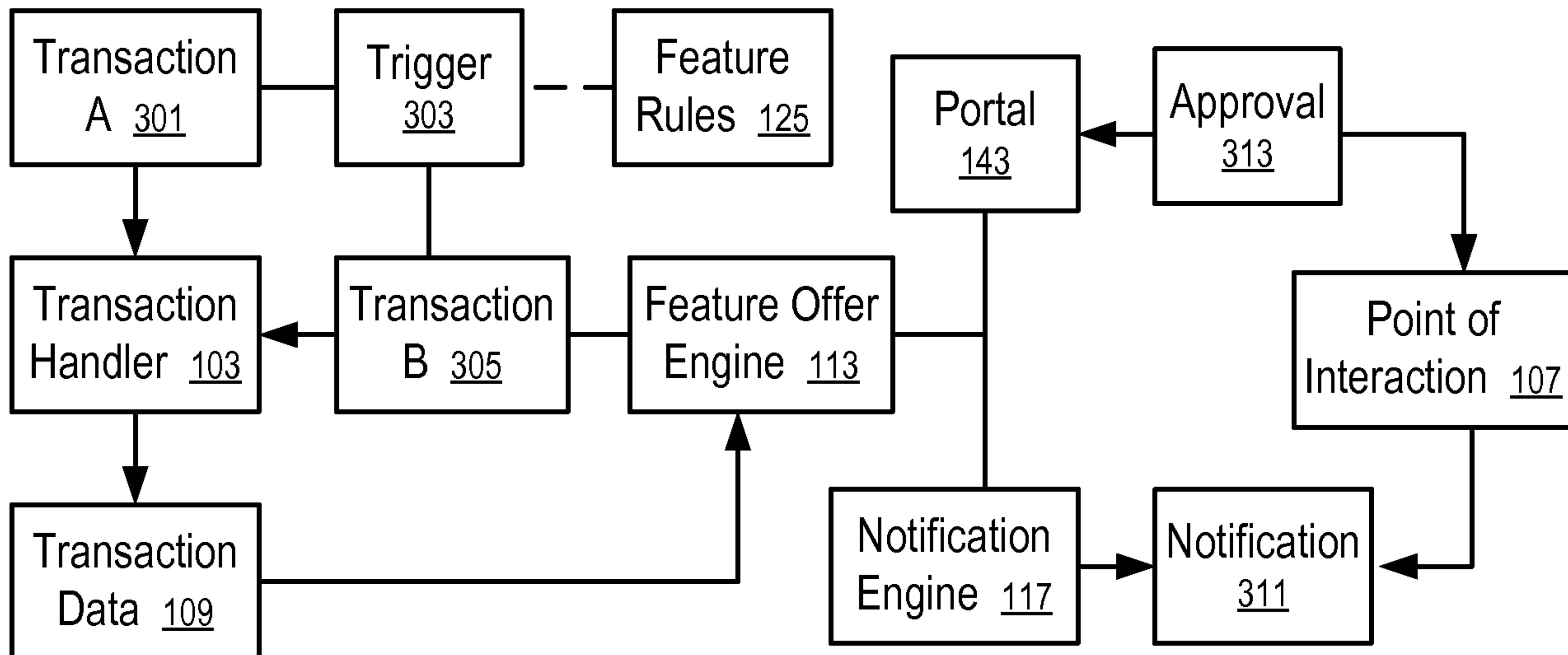

FIG. 2

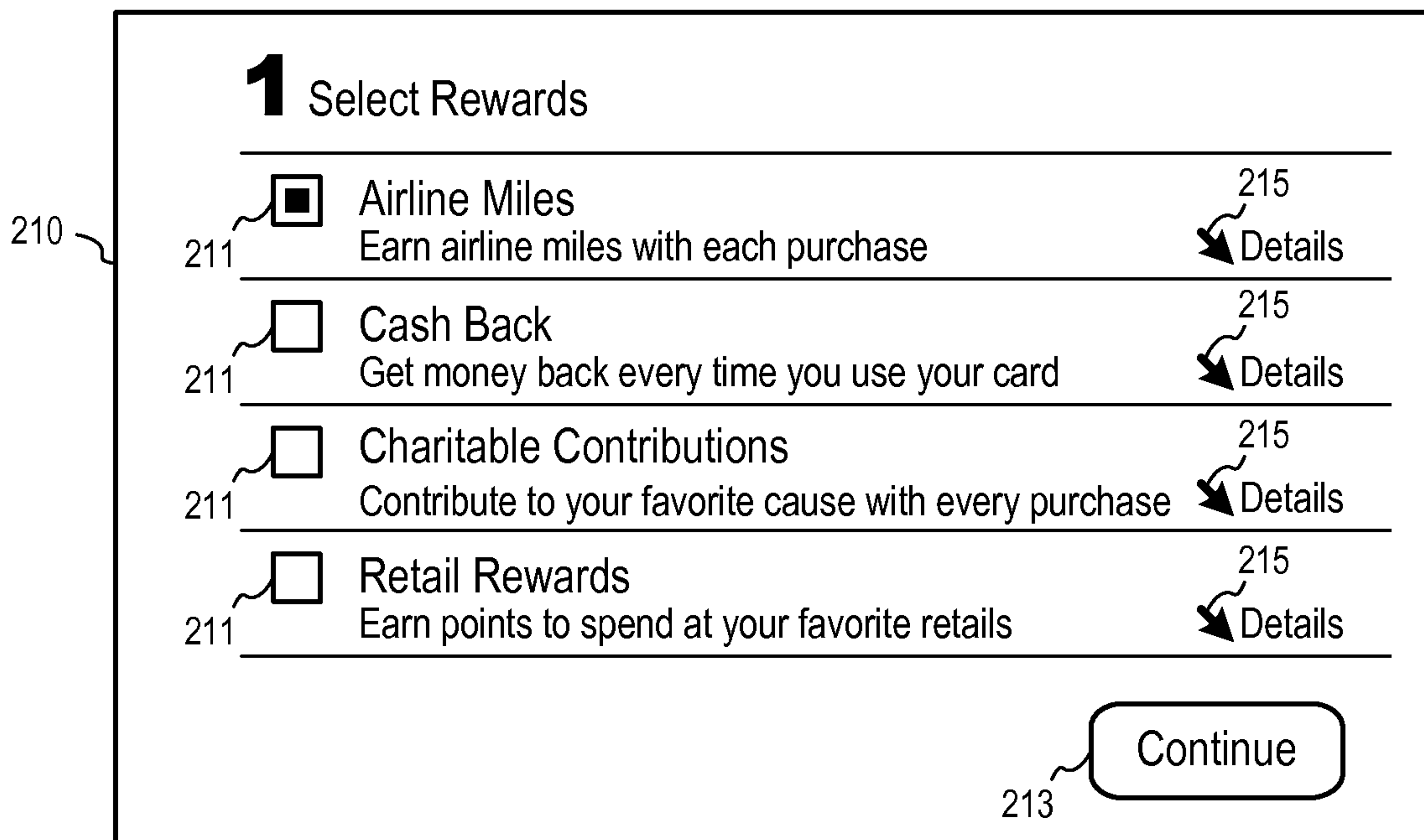

FIG. 3

3/9

2 Choose Benefits

Core Features	Annual Fee	Dollar Value
<input checked="" type="checkbox"/> Emergency Card Replacement Call for an emergency cash advance	Included	\$3
<input checked="" type="checkbox"/> Lost/Stolen Card Reporting Peace of mind	Included	\$100
<input checked="" type="checkbox"/> Zero Liability Shop worry-free at millions of merchants	Included	\$40

[Continue](#)

FIG. 4

2 Choose Benefits

Packages	
<input checked="" type="checkbox"/> Travel Package Enhance your travel experience	▼ Modify
<input type="checkbox"/> Retail Package Increase your purchasing power	▼ Modify

[Continue](#)

FIG. 5

2 Choose Benefits

Travel Package

<input checked="" type="checkbox"/>	Auto Rental Collision Damage Waiver Call for an emergency cash advance	▼ Details	<input type="checkbox"/>
<input checked="" type="checkbox"/>	Companion Airline Ticket Peace of mind	▼ Details	
<input checked="" type="checkbox"/>	Lost Luggage Reimbursement Shop worry-free at millions of merchants	▼ Details	

Continue

FIG. 6

3 Add-on & Options

Features	Annual Fee	Dollar Value	
<input checked="" type="checkbox"/> Personal Identity Theft ① Protect from unauthorized use	\$2	\$25	<input type="checkbox"/>
<input type="checkbox"/> Year-End Summary ① Receive an annual report of expenditures	\$2	\$100	
<input type="checkbox"/> Concierge Services ① Receive 24/7 access	\$25	\$300	

Continue

FIG. 7

4 Notification

About	Email	Text Msg	Voice Msg
Feature benefits	<input type="checkbox"/>	<input checked="" type="checkbox"/> 223	<input type="checkbox"/>
Eligible for new features	<input type="checkbox"/>	<input checked="" type="checkbox"/>	<input type="checkbox"/>
Annual reminder	<input type="checkbox"/>	<input checked="" type="checkbox"/>	<input type="checkbox"/>

Address

Email 221

Text Message 221

Voice Message 221

FIG. 8

5 Householding

Would you like to share your account features with other account holders in your household?

No

Yes. Share with the following account(s).

Account No.: 225

More ⇨

FIG. 9

6/9

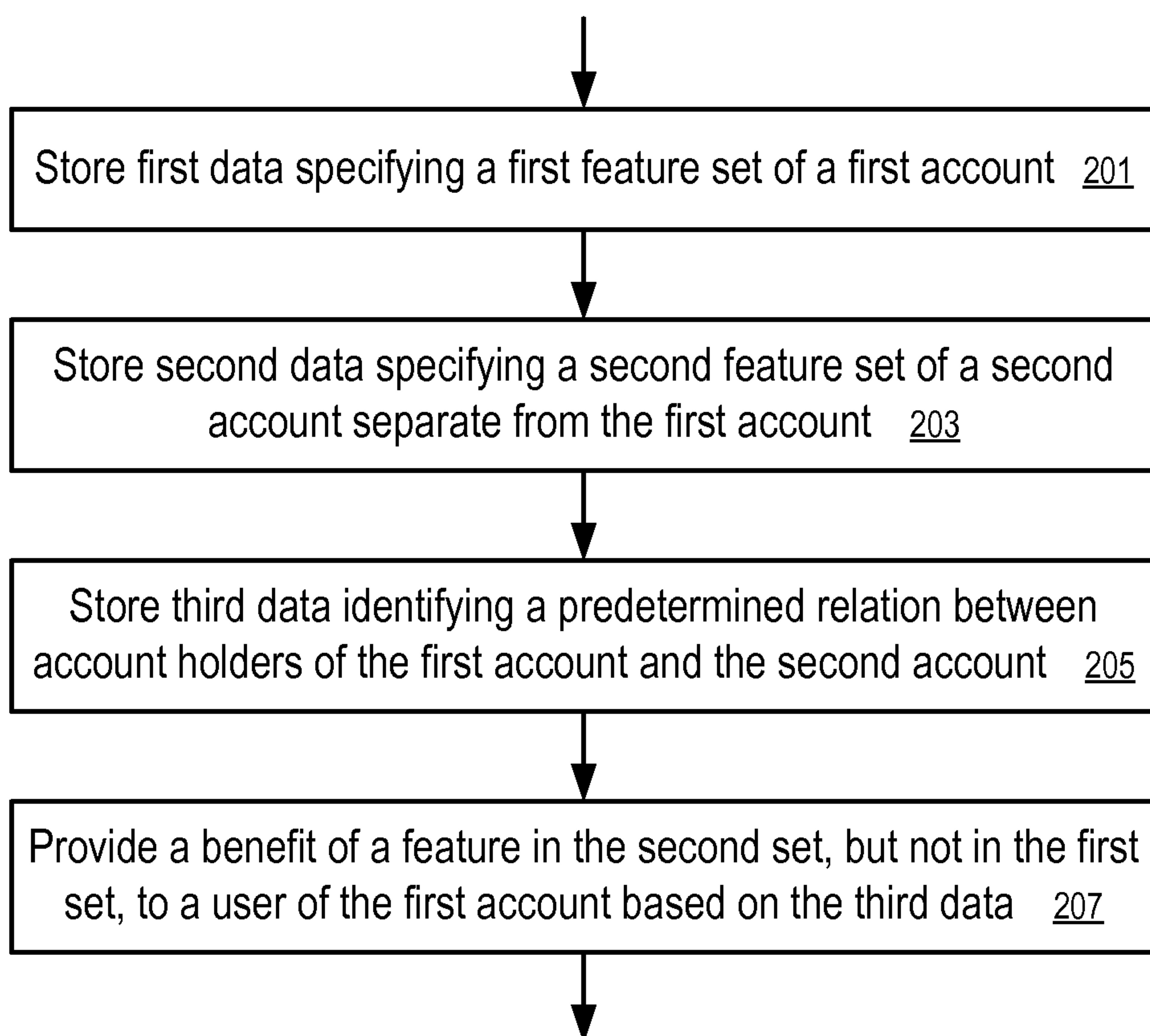

FIG. 10

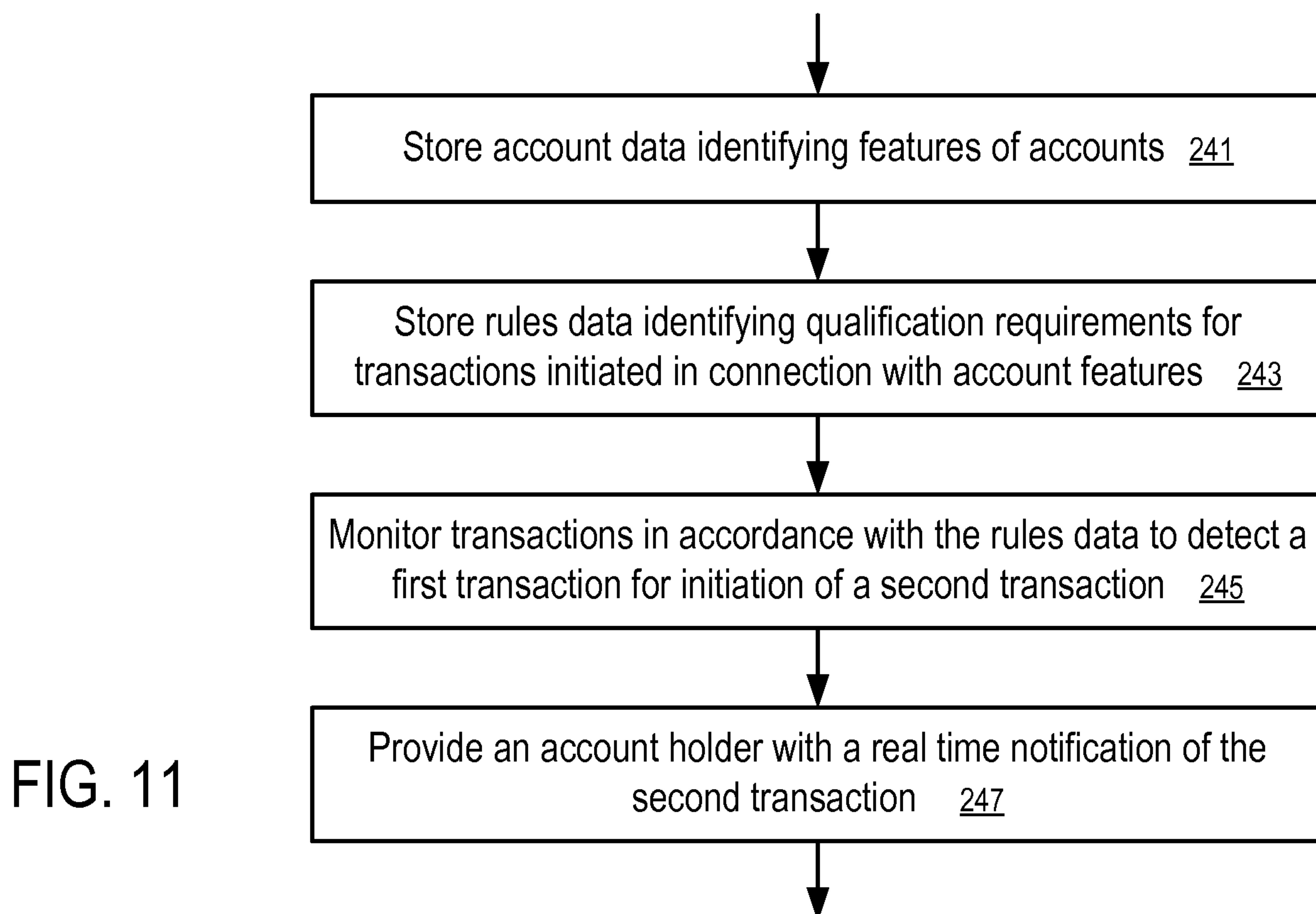

FIG. 11

7/9

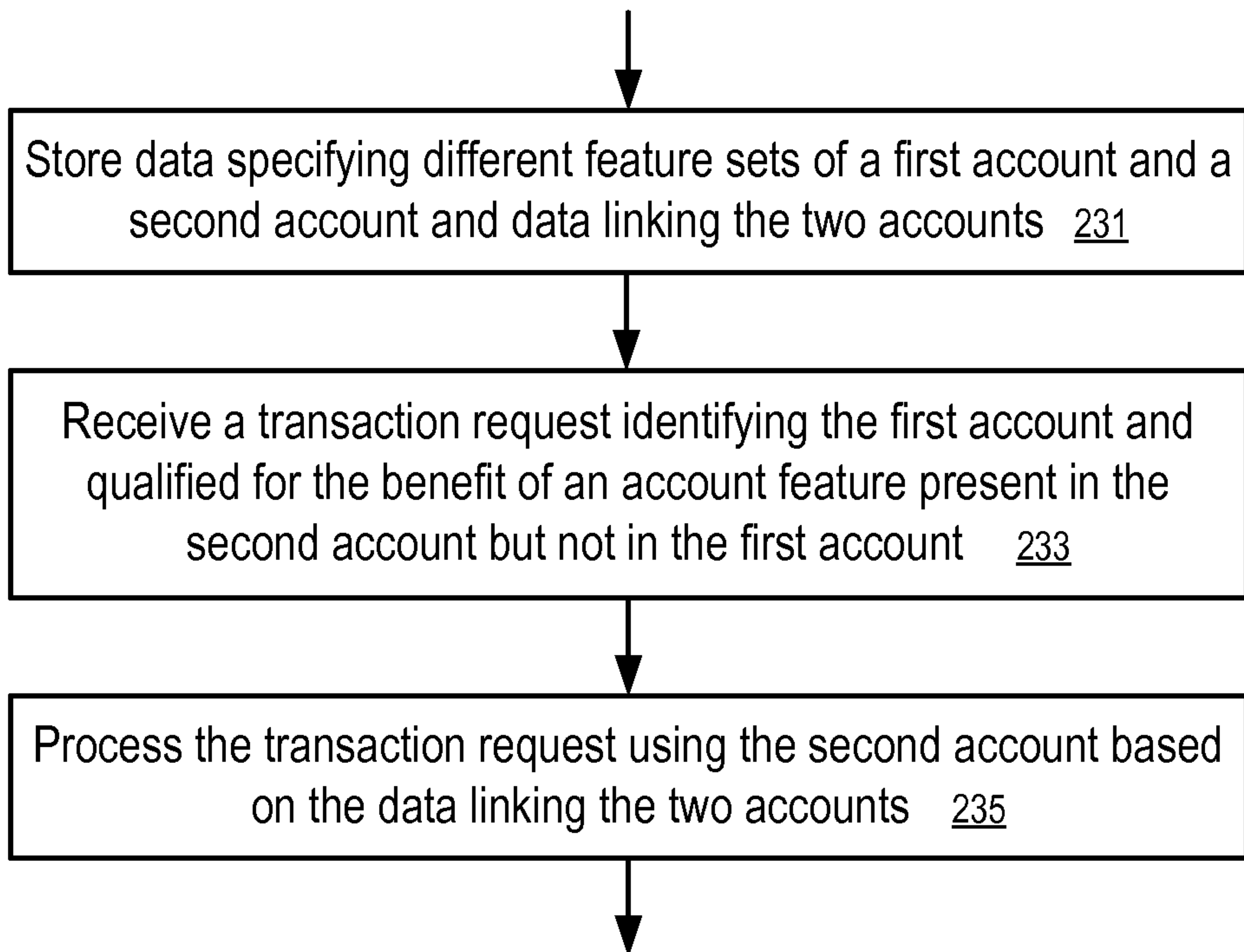

FIG. 12

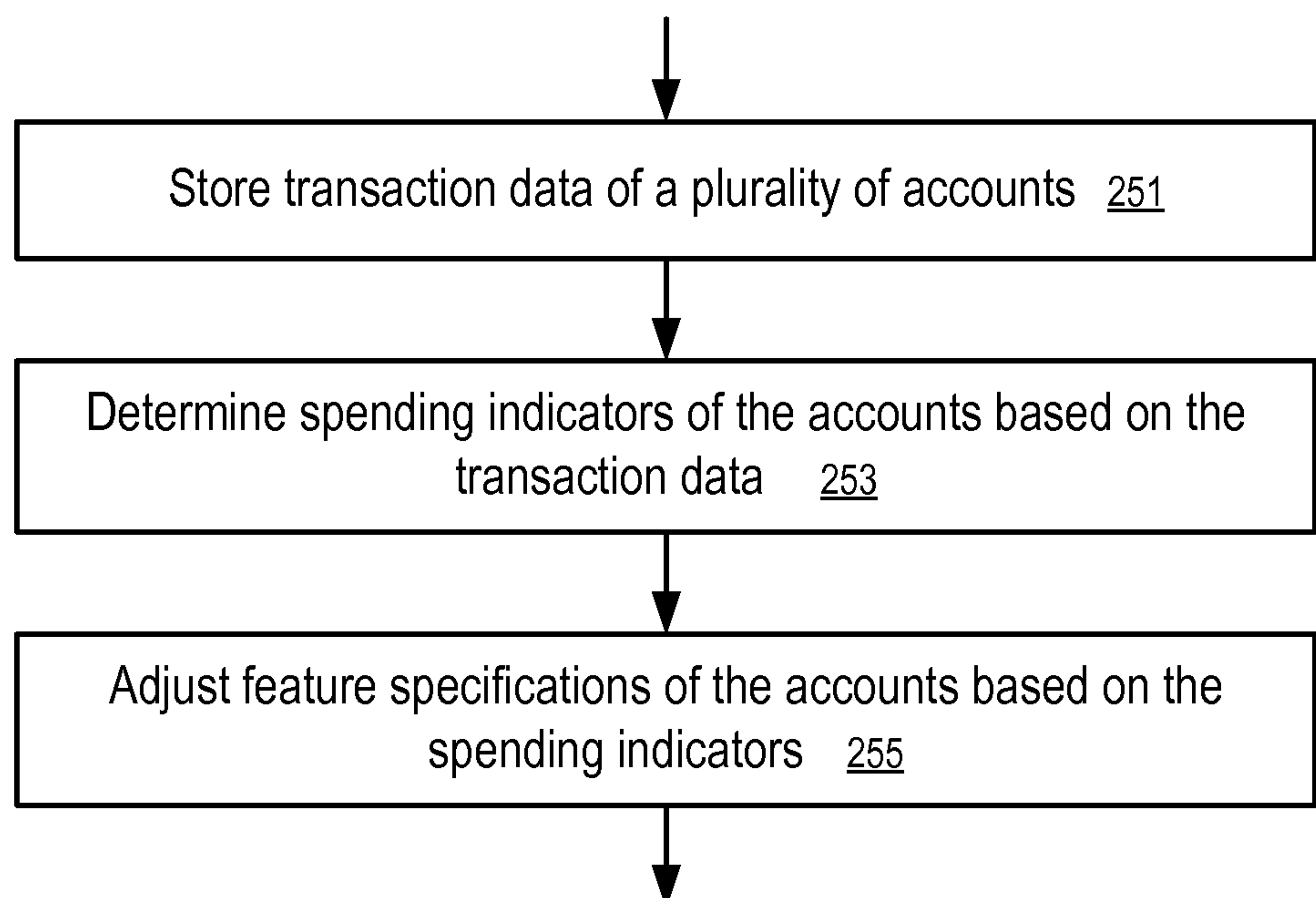

FIG. 13

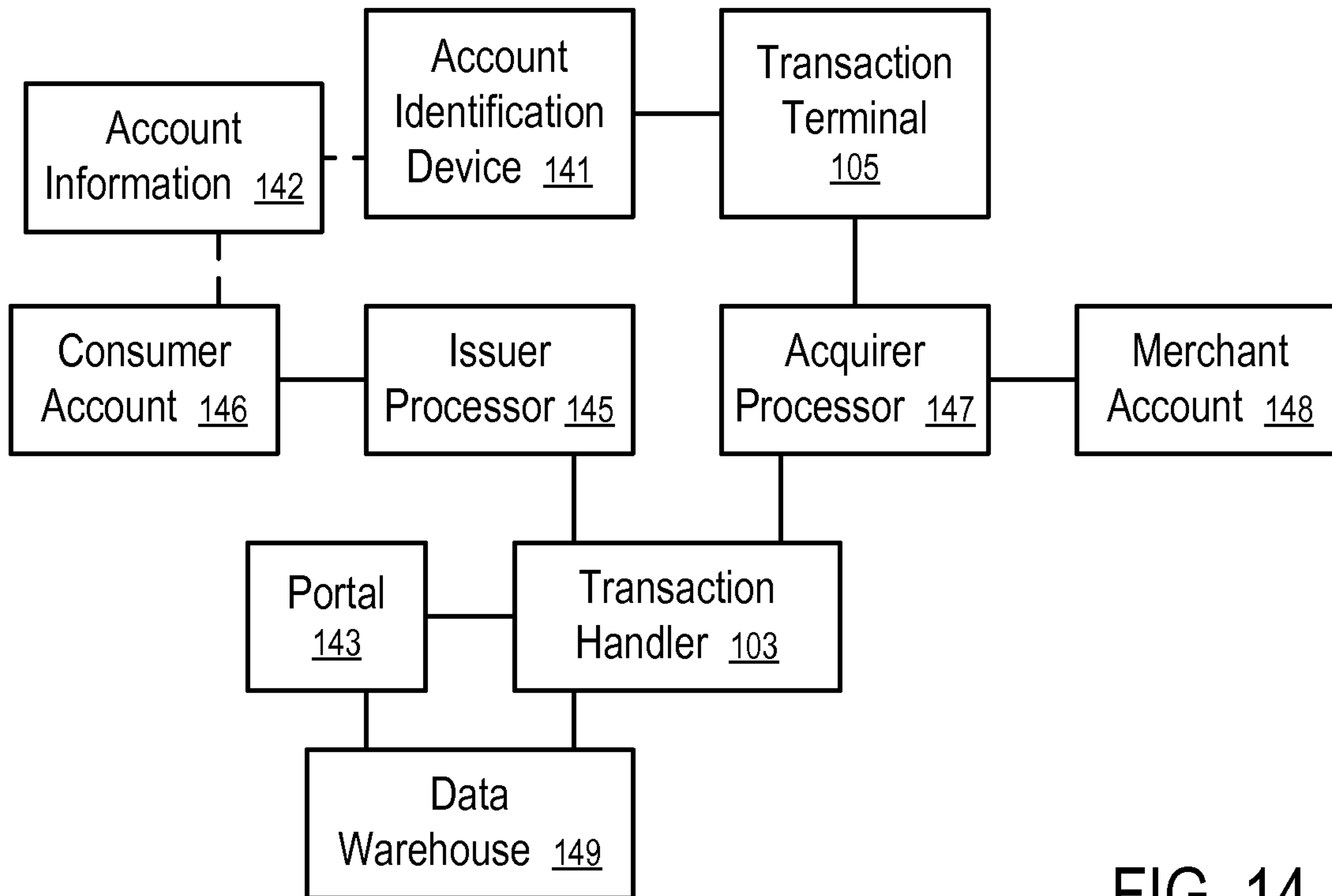

FIG. 14

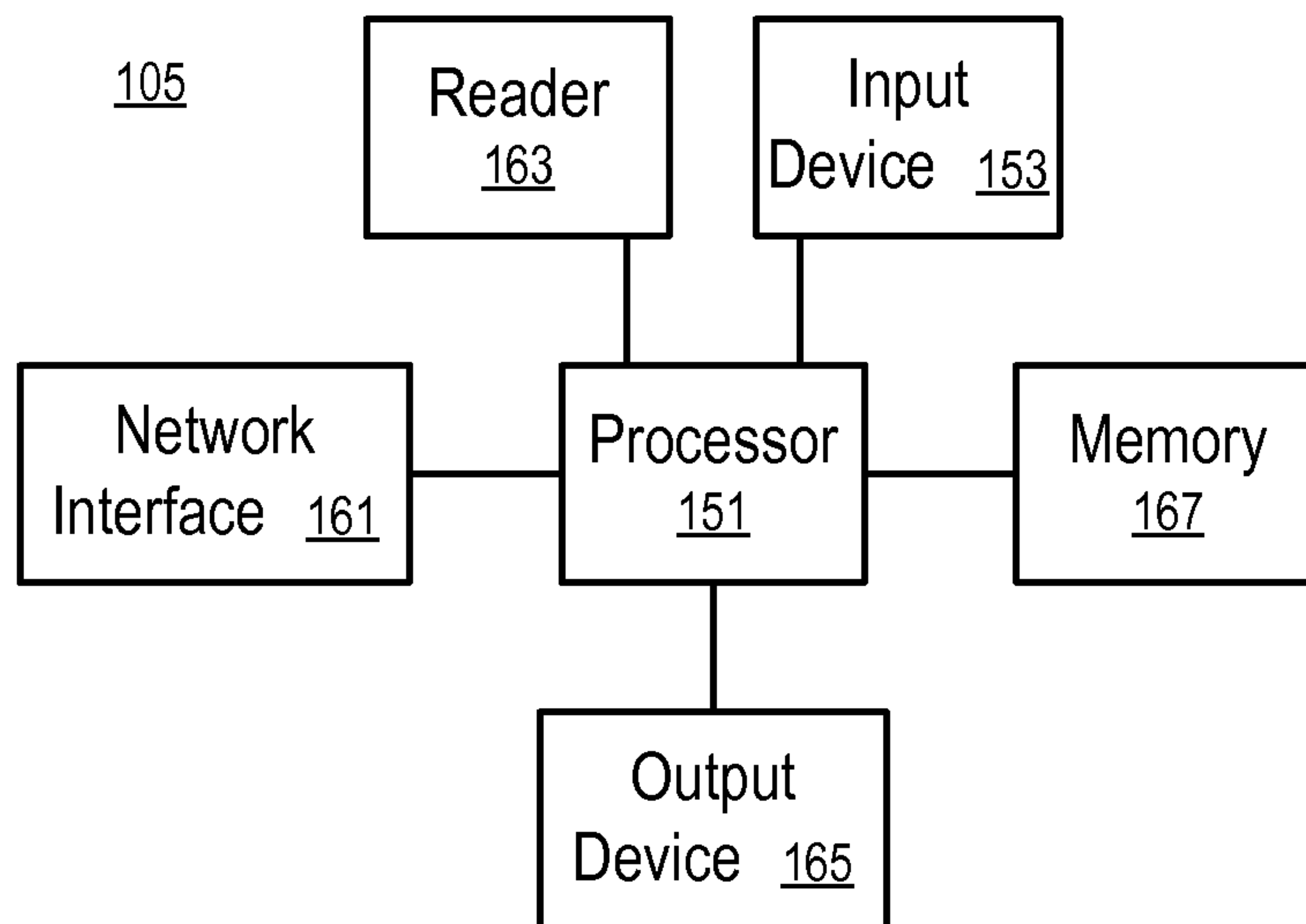

FIG. 15

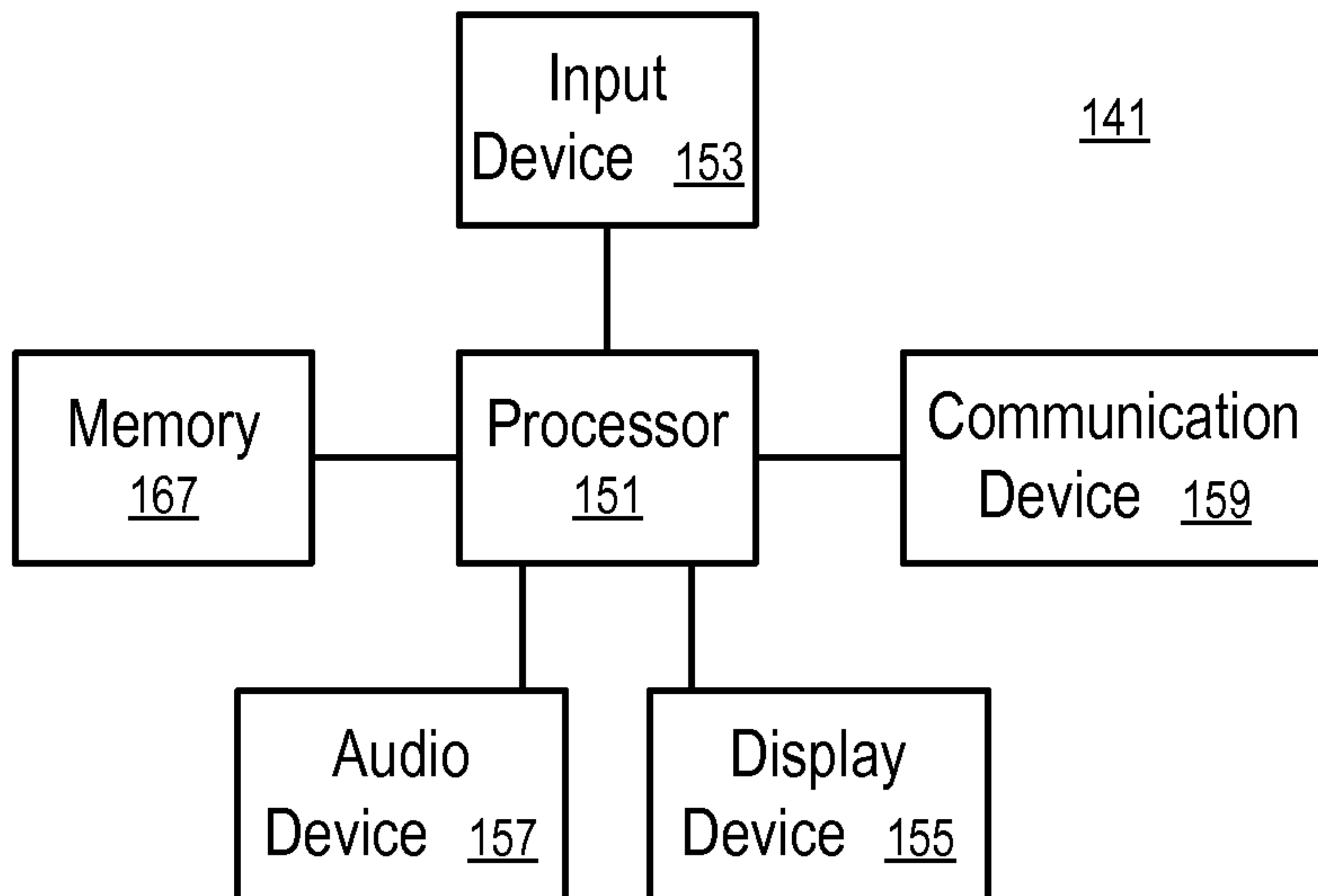

FIG. 16

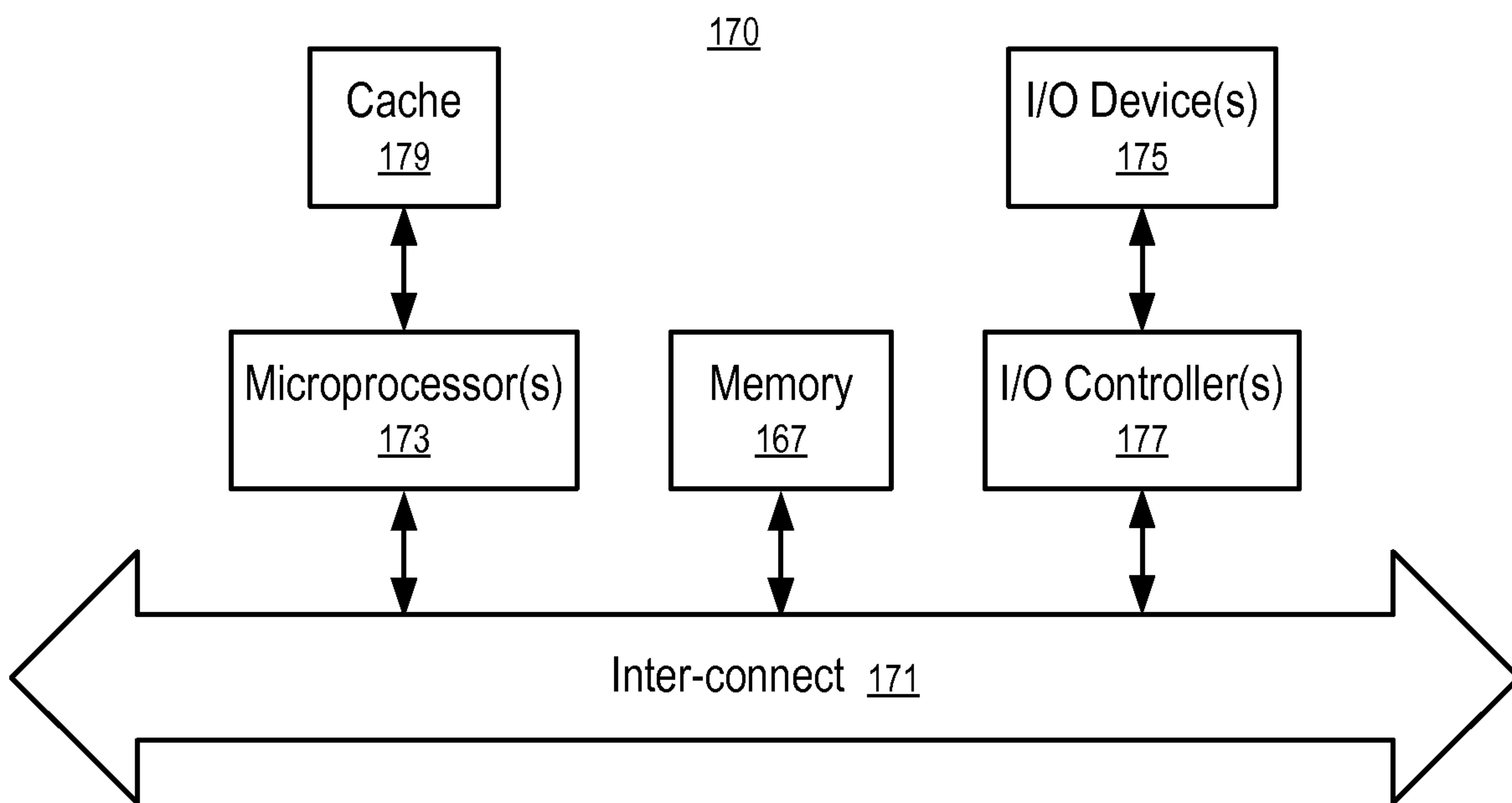

FIG. 17

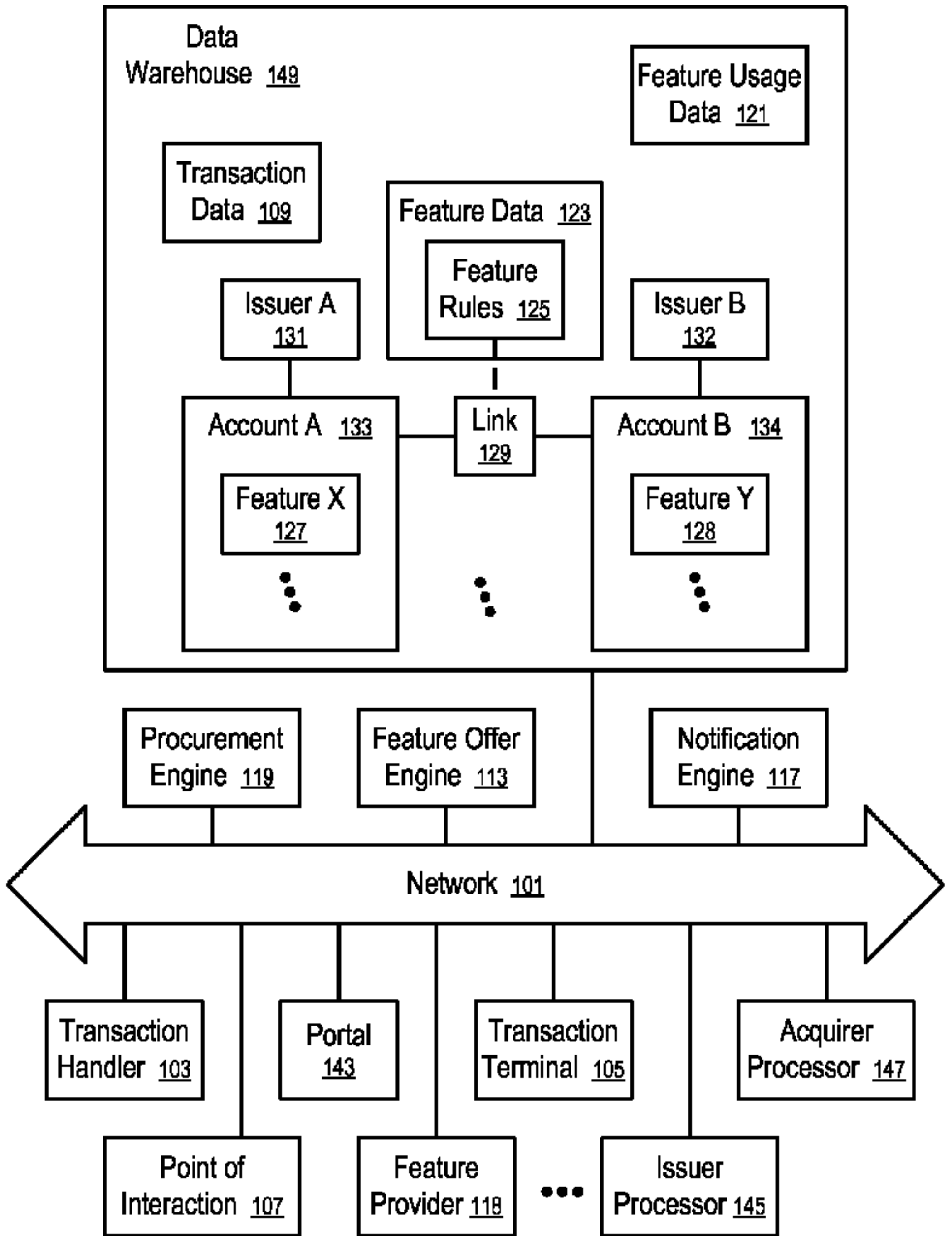

FIG. 1