



(19) **United States**

(12) **Patent Application Publication**
Chen

(10) **Pub. No.: US 2014/0116568 A1**

(43) **Pub. Date: May 1, 2014**

(54) **NET KNITTING METHOD**

(52) **U.S. Cl.**

(76) Inventor: **Chung-Ping Chen**, Pingtung County (CN)

CPC .. **B21F 27/12** (2013.01); **B21F 7/00** (2013.01)

USPC **140/6**; 66/170; 140/30

(21) Appl. No.: **14/126,874**

(57) **ABSTRACT**

(22) PCT Filed: **Sep. 21, 2011**

(86) PCT No.: **PCT/CN2011/079947**

§ 371 (c)(1),
(2), (4) Date: **Dec. 17, 2013**

(30) **Foreign Application Priority Data**

Jun. 23, 2011 (CN) 201110170661.5

Publication Classification

(51) **Int. Cl.**
B21F 27/12 (2006.01)
B21F 7/00 (2006.01)

Disclosed is a net knitting method. The knitting method comprises: leading multiple first thread materials (3a) and second thread materials (3b) through first rotating members (13a', 13b', 13c') and second rotating members (13a'', 13b'', 13c'') respectively, and cyclically and repeatedly performing the foregoing process through a step of rotating the first rotating members and the second rotating members simultaneously for an odd number of half circles and a step of staggering a first base (11') and a second base (11''), so as to form an obliquely knitted net. The knitting method can improve the structural strength of the net.

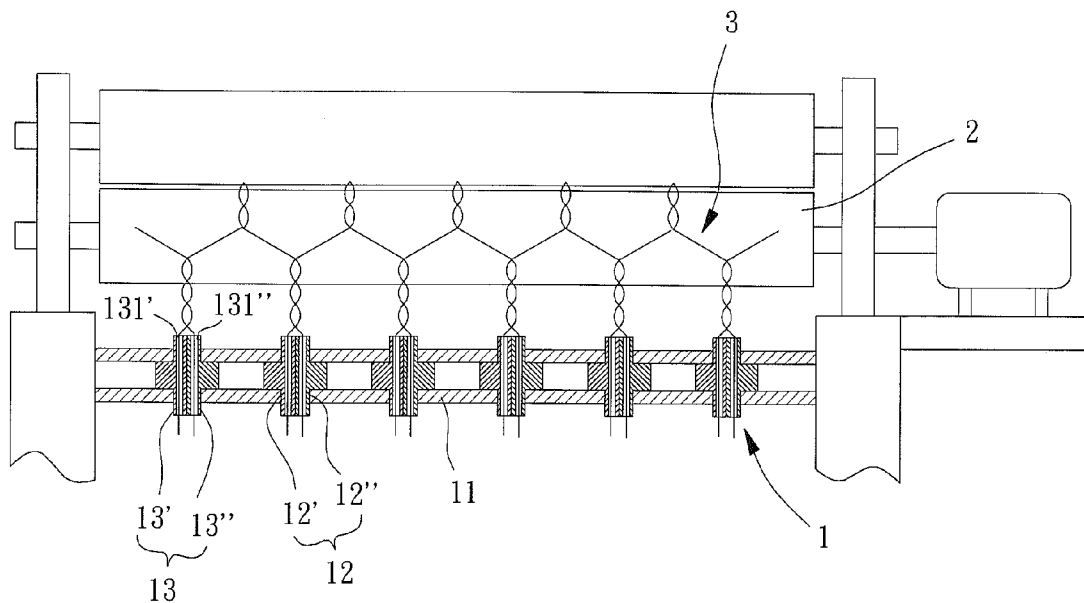

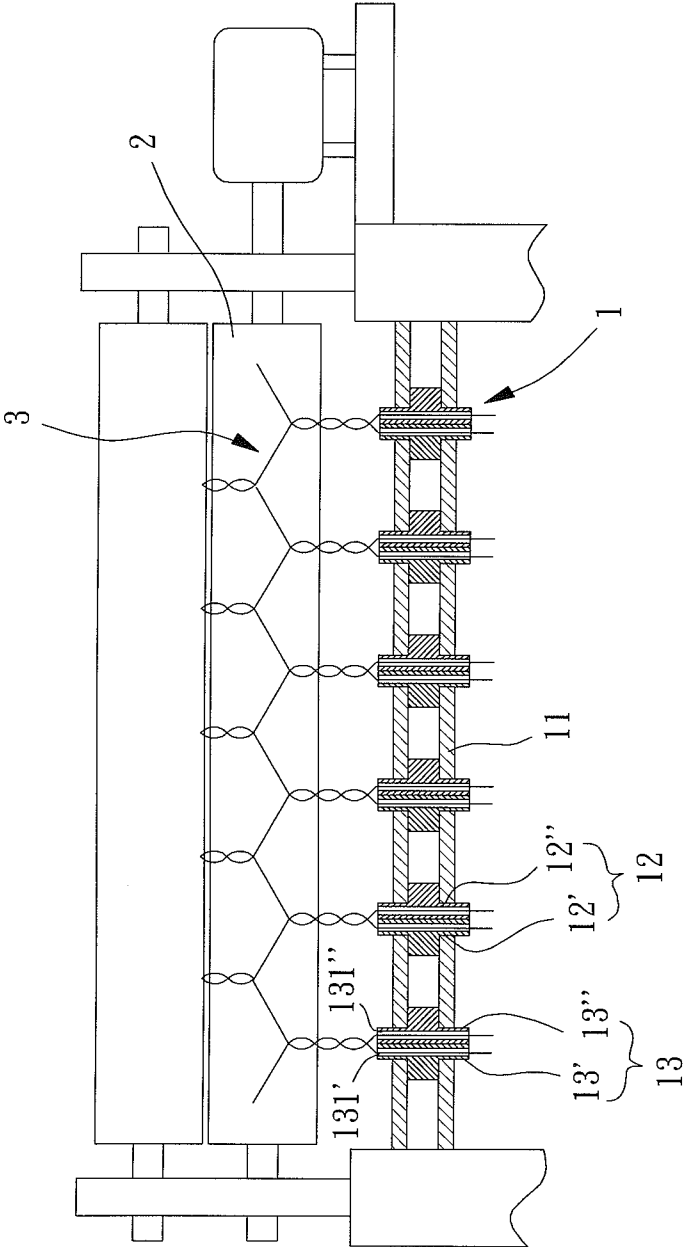

FIG. 1

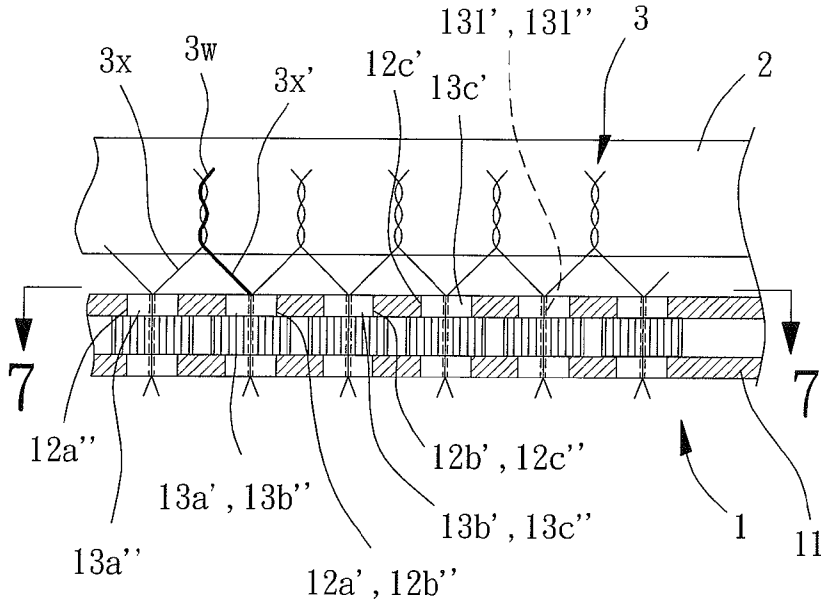

FIG. 6

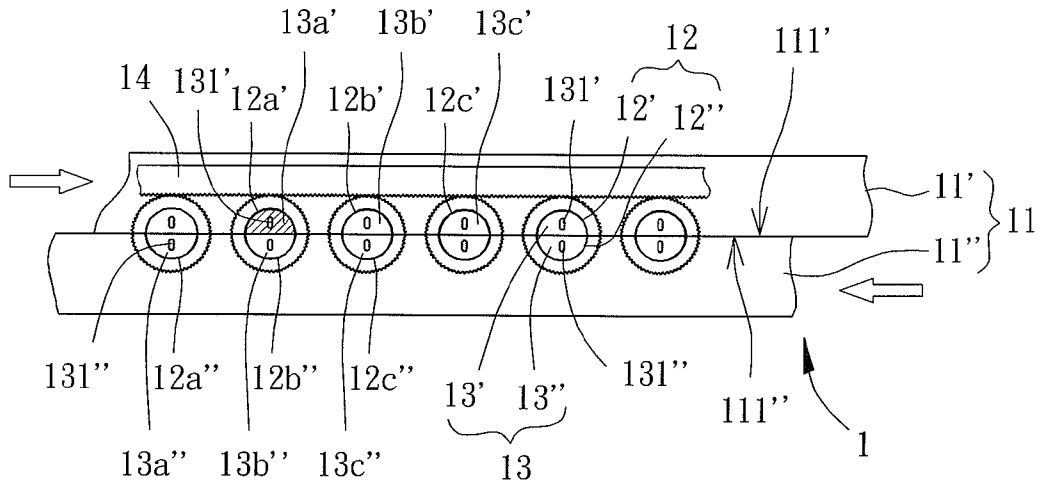

FIG. 7

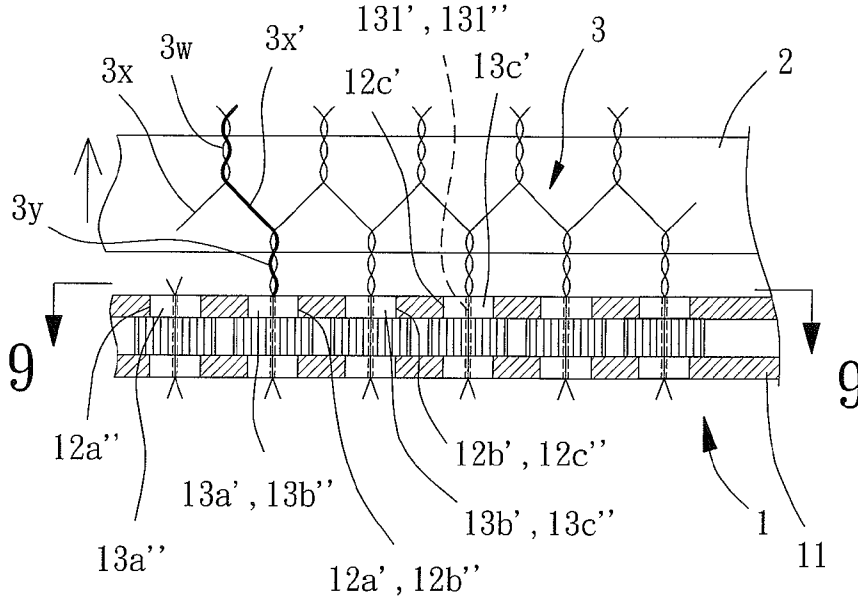

FIG. 8

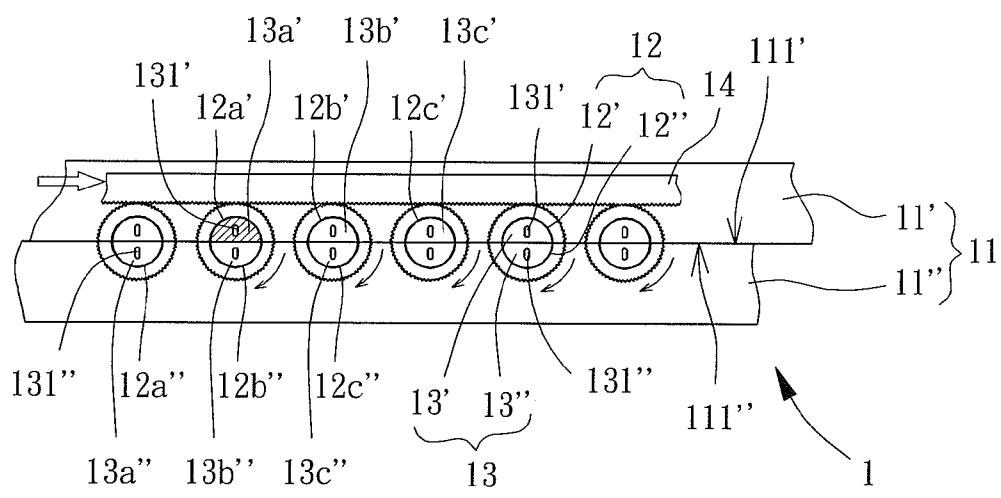

FIG. 9

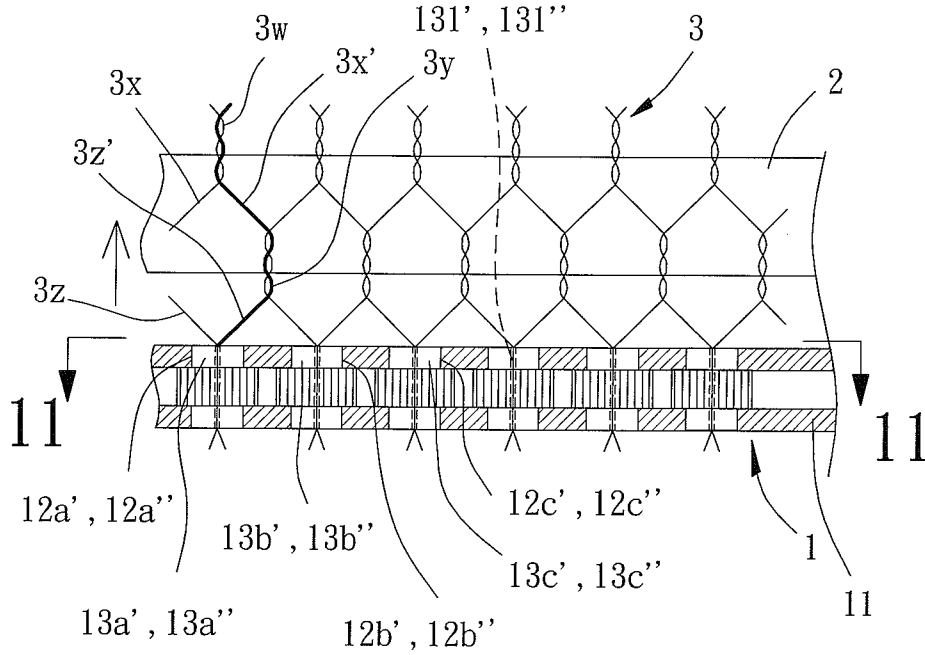

FIG. 10

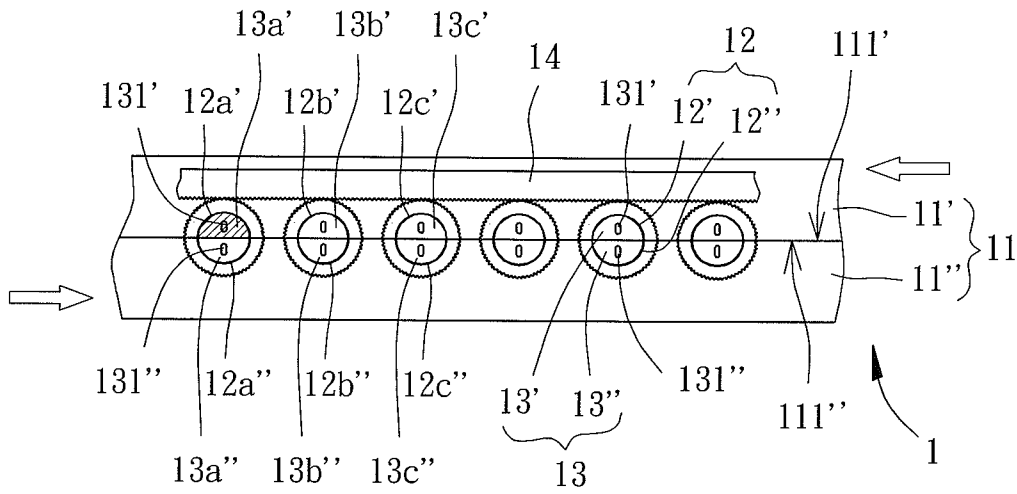

FIG. 11

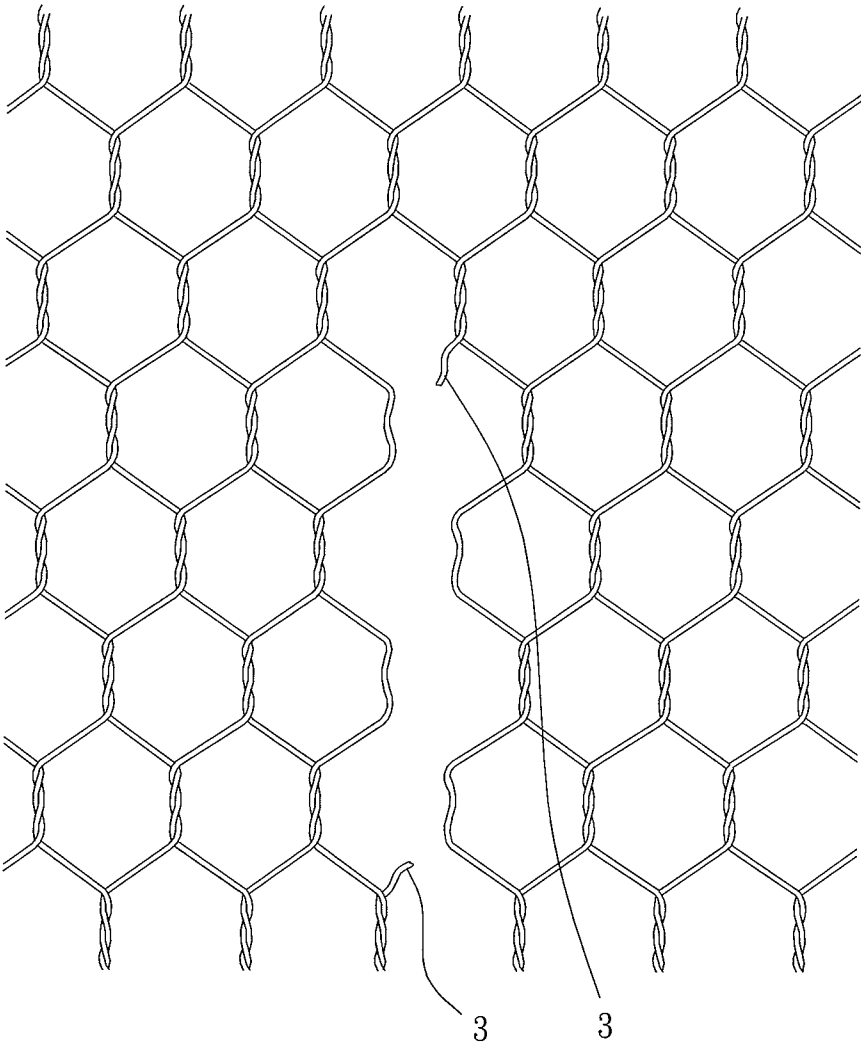

FIG. 12

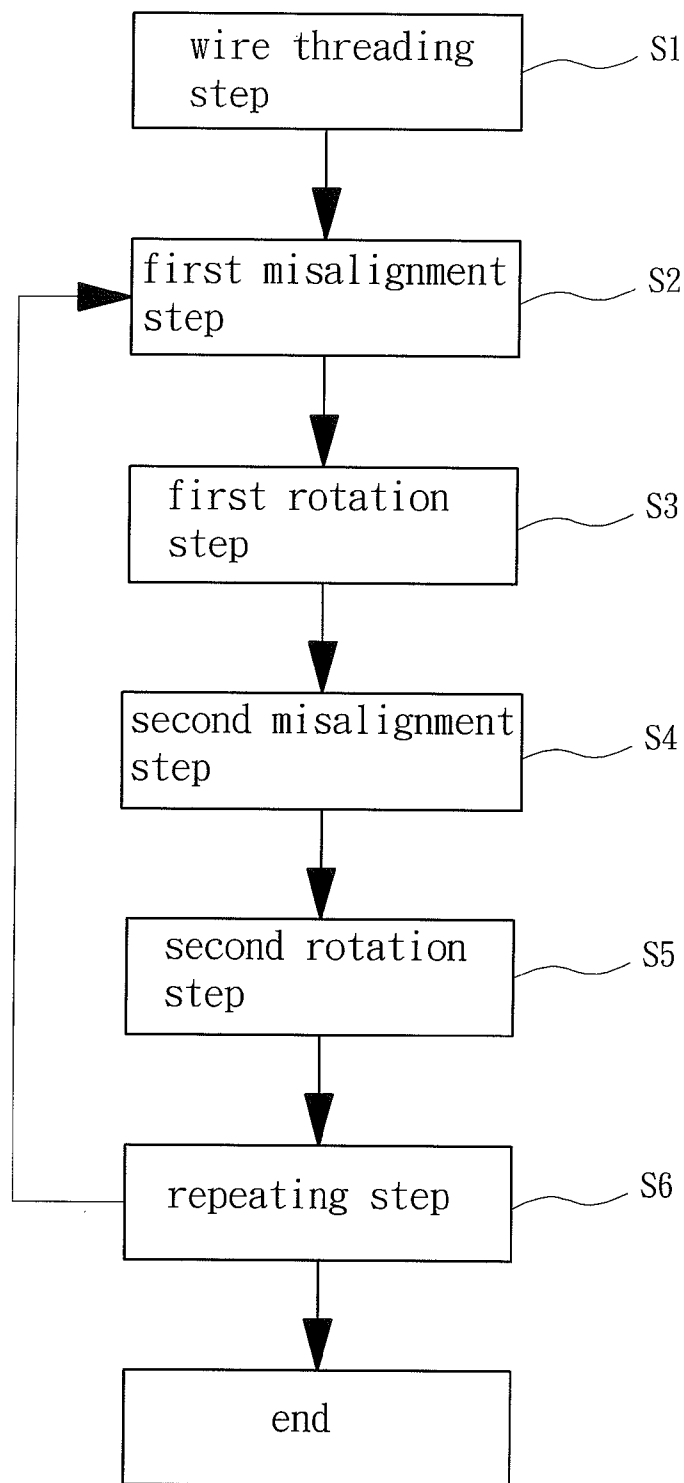

FIG. 13

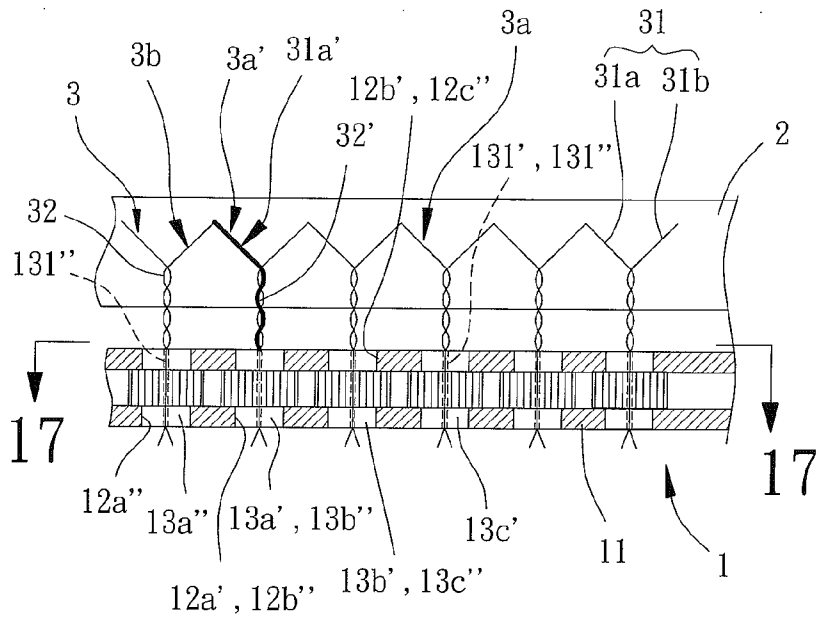

FIG. 16

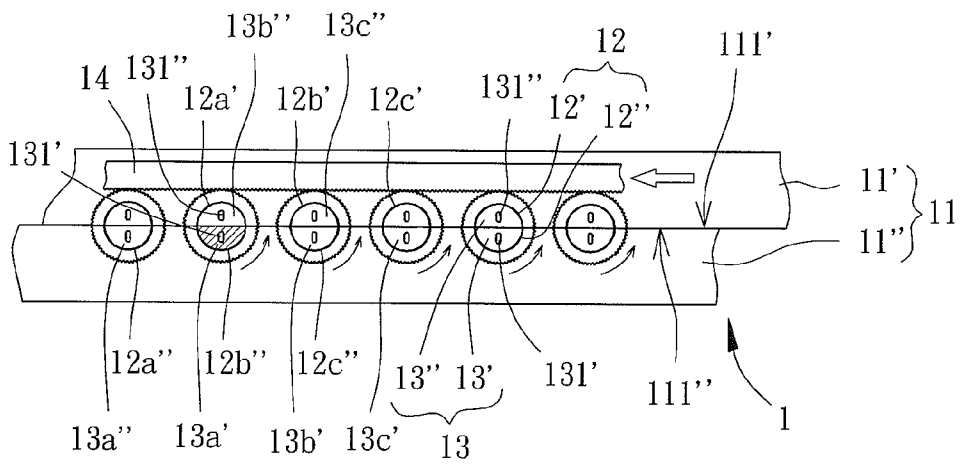

FIG. 17

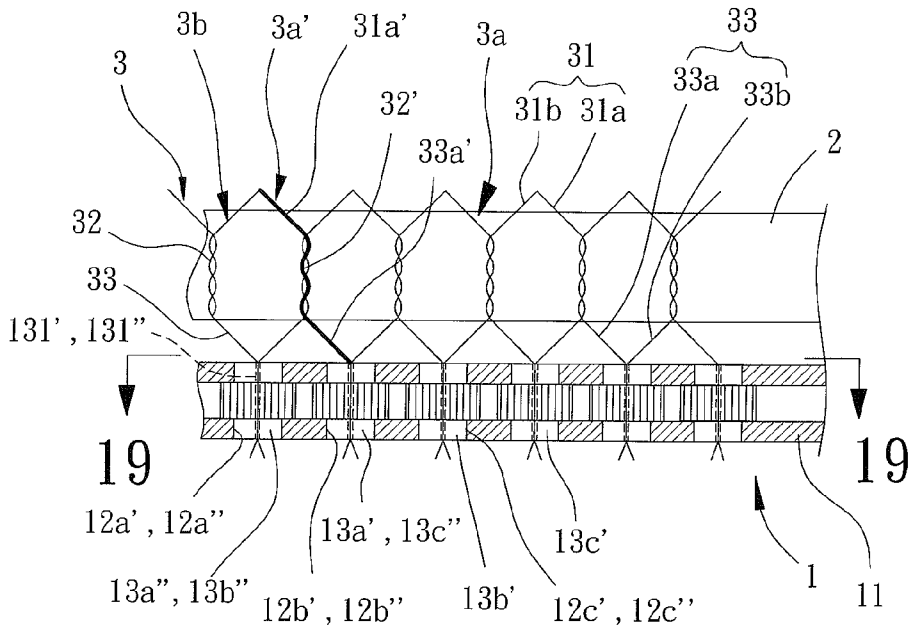

FIG. 18

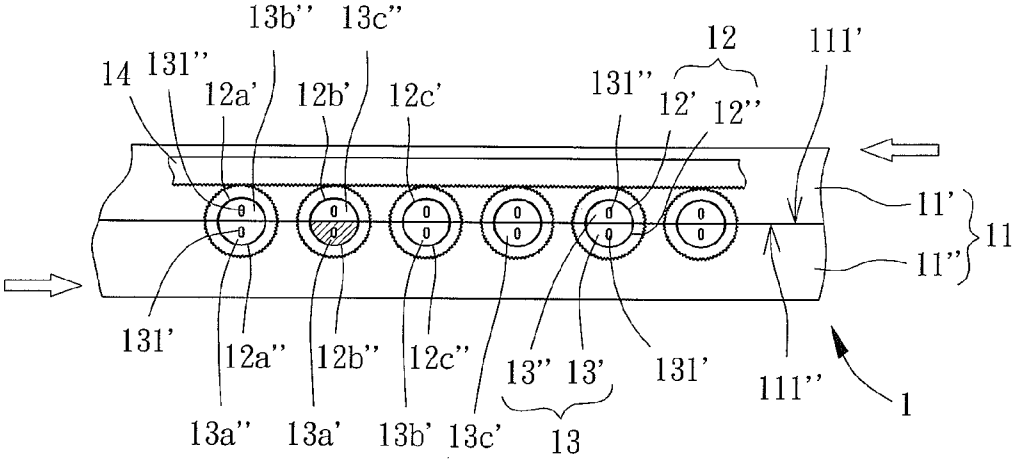

FIG. 19

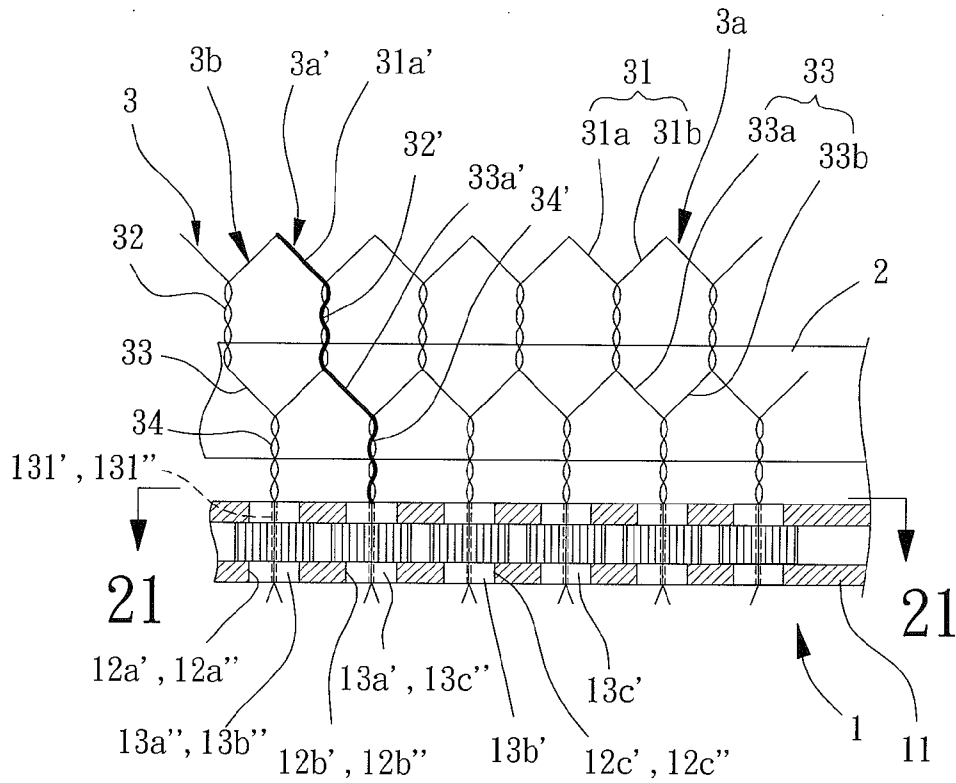

FIG. 20

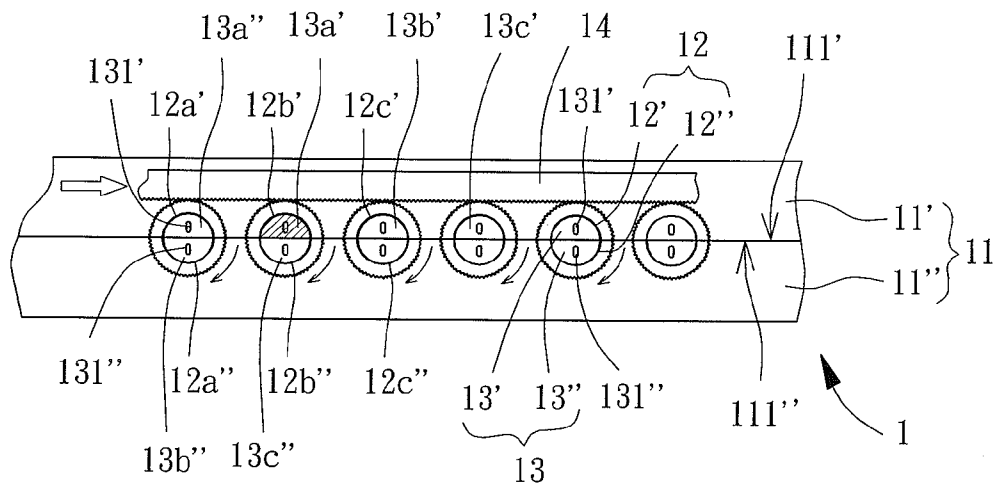

FIG. 21

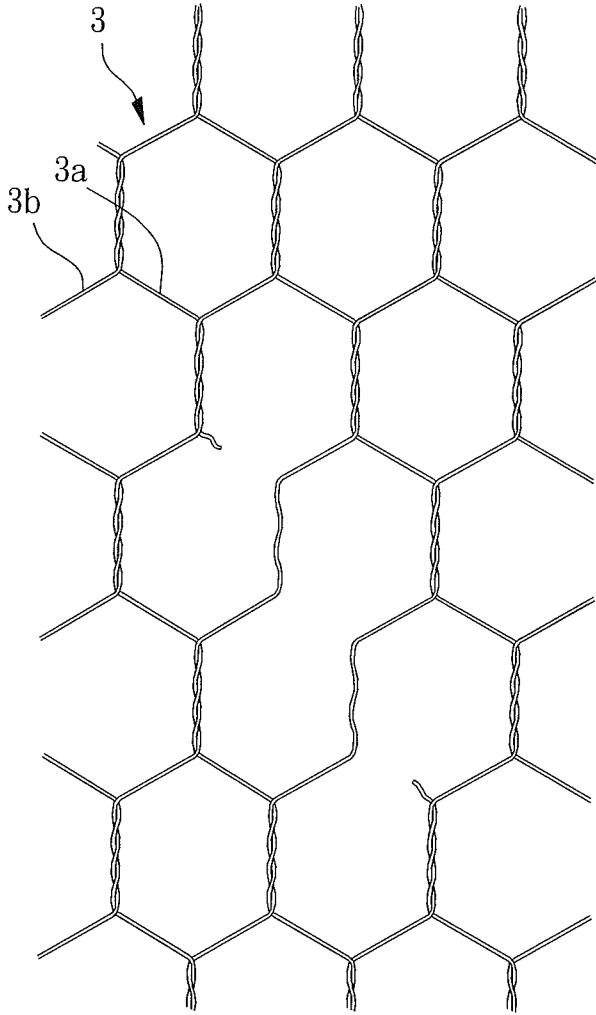

FIG. 24

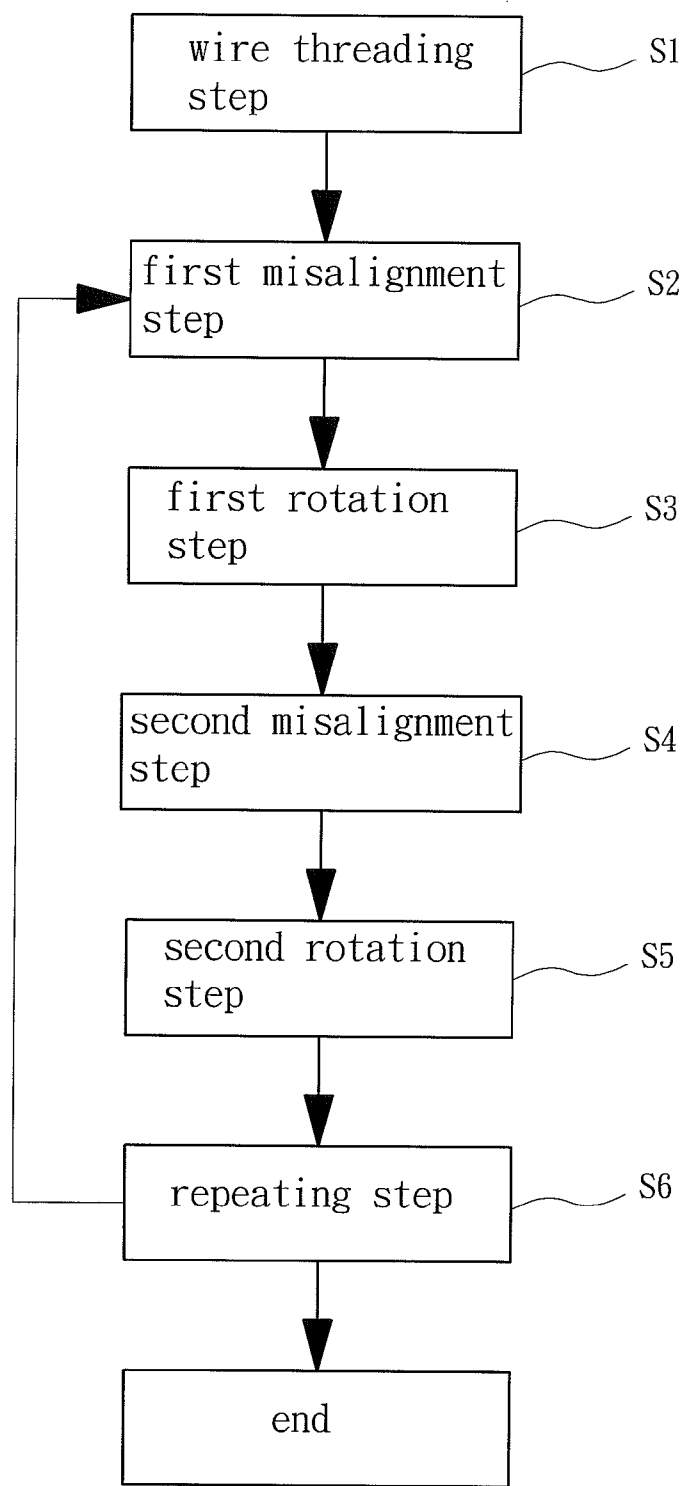

FIG. 25

NET KNITTING METHOD

BACKGROUND OF THE INVENTION

[0001] 1. Field of the Invention

[0002] The present invention relates to a net knitting method and, more particularly, to a net knitting method.

[0003] 2. Description of the Related Art

[0004] With reference to FIGS. 1-3, a conventional method for knitting woven objects is carried out on a weaving machine disclosed in Taiwan Patent Publication No. 252370 entitled "IMPROVED METAL GABION SPECIAL MACHINE" and Taiwan Patent Publication No. 291714 entitled "IMPROVED GABION WEAVING MACHINE". The weaving machine mainly includes a weaving unit 1. The weaving unit 1 includes a base assembly 11, a plurality of weaving holes 12, a plurality of rotating assemblies 13, and a driving member 14. The base assembly 11 is comprised of a first base 11' and a second base 11". The first base 11' has a first abutment face 111' abutting a second abutment face 111" of the second base 11". Each weaving hole 12 is comprised of a first half hole 12' and a second half hole 12". The first half holes 12' are formed in the first abutment face 111' of the first base 11'. The second half holes 12" are formed in the second abutment face 111" of the second base 11". Each first half hole 12' (12a', 12b', 12c') is aligned with one of the second half holes 12" (12a", 12b", 12c") to form a weaving hole 12. Each rotating assembly 13 is rotatably received in one of the weaving holes 12 and includes two wire holes 131. Each rotating assembly 13 is comprised of a first rotating member 13' (13a', 13b', 13c') and a second rotating member 13" (13a", 13b", 13c"). Each first rotating member 13' has a first wire hole 131', and each second rotating member 13" has a second wire hole 131". Wires 3, 3a, 3b thread through the first and second wire holes 131' and 131". The driving member 14 is used to drive the rotating assemblies 13 to rotate. As an example, each rotating assembly 13 has teeth on an outer periphery thereof, and the driving member 14 has a toothed section to drive the rotating assemblies 13 to rotate.

[0005] The weaving machine preferably includes a coiling unit 2 on a side of the weaving unit 1. The coiling unit 2 is driven by a power unit to coil a net formed after weaving.

[0006] With reference to FIGS. 2 and 3, the conventional method for knitting a net includes threading a wire 3 through each wire hole 131, with an end of the wire 3 extending through the wire hole 131 and then extending toward the coiling unit 2. The wires 3 are continuously coiled and pulled by the coiling unit 2. The subsequent steps will be described in connection with the first rotating member 13a', 13b', 13c' and the second rotating member 13a", 13b", 13c" in FIG. 3.

[0007] With reference to FIGS. 3-5, the driving member 14 is then used to drive the rotating assemblies 13 to rotate a plurality of full-cycle turns, such as two turns or three turns, such that the first rotating member 13a', 13b', 13c' and the second rotating member 13a", 13b", 13c" are still respectively located in the first half hole 12' and the second hole 12" after full-cycle rotation. By continuous coiling and pulling by the coiling unit 2, a first row of twine portions 3w is obtained, as shown in FIG. 4.

[0008] With reference to FIGS. 5-7, the first base 11' and the second base 11" are then moved relative to the first abutment face 111' and the second abutment face 111", respectively. In an example shown in FIG. 1, the first base 11' is moved rightward (first direction) to a position in which each first half hole 12a' moves rightward to a location aligned with

the second half hole 12b", with the first half hole 12a' and the second half hole 12b" together forming a weaving hole 12. The first rotating member 13a' and the second rotating member 13b" are located in the same weaving hole 12. Thus, an extension 3x extends from each of two sides of each twine portion 3w, as shown in FIG. 6. As an example, rightward displacement of the first rotating member 13a' causes the twine portion 3w to extend rightward to form the extension 3x'.

[0009] With reference to FIGS. 7-9, next, the driving member 14 again drives the rotating assemblies 13 to rotate a plurality of full-cycle turns to produce a second row of twine portions 3y.

[0010] With reference to FIGS. 9-11, then, the first base 11' and the second base 11" are again moved relative to the first abutment face 111' and the second abutment face 111", respectively. In an example shown in FIG. 11, the first base 11' is moved leftward to a position in which each first half hole 12' moves leftward to a location aligned with the originally corresponding second half hole 12", with the first half hole 12' and the second half hole 12" together forming a weaving hole 12. The first rotating member 13a' and the originally corresponding second rotating member 13a" are located in the same weaving hole 12. Thus, an extension 3z extends from each of two sides of each twine portion 3y, as shown in FIG. 10. As an example, leftward displacement of the first rotating member 13a' causes the twine portion 3y to extend leftward to form the extension 3z'.

[0011] By repeating the steps of rotating the rotating assemblies 13 a plurality of full-cycle turns, displacing the first rotating members 13' and the second rotating members 13" to provide misalignment, rotating the rotating assemblies 13 a plurality of full-cycle turns, and displacing the first rotating members 13' and the second rotating members 13" to their original position, each wire 3 will extend vertically in an S-shaped route, forming a net through weaving.

[0012] However, if one of the wires 3 of the net produced from the conventional method for knitting a net is broken, a large, elongated hole will be generated, as shown in FIG. 12. Thus, the objects wrapped by the net are liable to pass through the large hole. As a result, the overall structural strength is poor, and large holes are apt to occur.

[0013] Thus, a need exists for an improved method for knitting a net in view of the above reasons.

SUMMARY OF THE INVENTION

[0014] An objective of the present invention is to provide a method for knitting a net to increase the overall structural strength of the net to avoiding occurrence of large holes.

[0015] A method for knitting a net according to the present invention includes a method for knitting a net includes: a wire threading step including threading each of a plurality of first wires through a first rotating member and threading each of a plurality of second wires through a second rotating member; a first misalignment step including controlling a first base and a second base to displace from an initial state to a misaligned state, causing the plurality of first wires and the plurality of second wires to respectively extend in a first direction and a second direction to form extensions; a first rotation step including jointly rotating the first rotating members and the second rotating members an odd number of half turns, causing the plurality of first wires and the plurality of second wires to intertwine with each other to form twine portions; a second misalignment step including displacing the first base and the

second base from the misaligned state to the initial state, causing the plurality of first wires and the plurality of second wires to respectively extend in the first direction and the second direction to form extensions; a second rotation step including jointly rotating the first rotating members and the second rotating members an odd number of half turns, causing the plurality of first wires and the plurality of second wires to intertwine with each other to form twine portions; and a repeating step including repeating the first misalignment step through the second rotation step until a net formed by the extensions and the twine portions reaches a predetermined size.

[0016] Weaving is carried out in a sequence of the wire threading step, the first misalignment step, the first rotation step, the second misalignment step, the second rotation step, and the repeating step or in a sequence of the wire threading step, the first rotation step, the first misalignment step, the second rotation step, the second misalignment step, and the repeating step.

[0017] An end of each of the plurality of first wires and an end of each of the plurality of second wires are pulled away from the first base and the second base.

[0018] In that in the second misalignment step, the first base and the second base undergo misalignment displacement in misalignment directions reverse to the first misalignment back to the initial state.

[0019] The rotating direction in the first rotation step is same as the rotating direction in the second rotation step.

[0020] The rotating direction in the first rotation step is opposite to the rotating direction in the second rotation step.

[0021] The advantageous effect of the present invention is that the net formed by the method according to the present invention can avoid large holes. Thus, the present invention provides an effect of increasing the overall structural strength of the net.

[0022] The objectives, features, and advantages of the present invention will become clearer in light of the following detailed description of illustrative embodiments of this invention described in connection with the accompanying drawings.

BRIEF DESCRIPTION OF THE DRAWINGS

[0023] FIG. 1 is a view showing a structure of a conventional weaving machine.

[0024] FIG. 2 is a schematic view of the conventional weaving machine after threading of wires.

[0025] FIG. 3 is another schematic view of the conventional weaving machine after threading of wires.

[0026] FIG. 4 is a schematic view illustrating action of a procedure of a conventional method for knitting a net.

[0027] FIG. 5 is another schematic view illustrating action of the procedure of the conventional method for knitting a net.

[0028] FIG. 6 is a schematic view illustrating action of another procedure of the conventional method for knitting a net.

[0029] FIG. 7 is another schematic view illustrating action of another procedure of the conventional method for knitting a net.

[0030] FIG. 8 is a schematic view illustrating action of a further procedure of the conventional method for knitting a net.

[0031] FIG. 9 is another schematic view illustrating action of a further procedure of the conventional method for knitting a net.

[0032] FIG. 10 is a schematic view illustrating action of still another procedure of the conventional method for knitting a net.

[0033] FIG. 11 is another schematic view illustrating action of still another procedure of the conventional method for knitting a net.

[0034] FIG. 12 is a schematic view illustrating a net made by the conventional method for knitting a net, with the net broken.

[0035] FIG. 13 is a flowchart of a method for knitting a net according to the present invention.

[0036] FIG. 14 is a schematic view illustrating action of a first misalignment step of the method for knitting a net according to the present invention.

[0037] FIG. 15 is another schematic view illustrating action of the first misalignment step of the method for knitting a net according to the present invention.

[0038] FIG. 16 is a schematic view illustrating action of a first rotation step of the method for knitting a net according to the present invention.

[0039] FIG. 17 is another schematic view illustrating action of the first rotation step of the method for knitting a net according to the present invention.

[0040] FIG. 18 is a schematic view illustrating action of a second misalignment step of the method for knitting a net according to the present invention.

[0041] FIG. 19 is another schematic view illustrating action of the second misalignment step of the method for knitting a net according to the present invention.

[0042] FIG. 20 is a schematic view illustrating action of a second rotation step of the method for knitting a net according to the present invention.

[0043] FIG. 21 is another schematic view illustrating action of the second rotation step of the method for knitting a net according to the present invention.

[0044] FIG. 22 is a schematic view illustrating action of repeating the first misalignment step of the method for knitting a net according to the present invention.

[0045] FIG. 23 is another schematic view illustrating action of repeating the first misalignment step of the method for knitting a net according to the present invention.

[0046] FIG. 24 is a schematic view illustrating a net made by the method for knitting a net according to the present invention, with the net broken.

[0047] FIG. 25 is another flowchart of the method for knitting a net according to the present invention.

[0048]

Reference numbers of elements:

1 weaving unit	11 base assembly
11' first base	11" second base
111' first abutment face	111" second abutment face
12 weaving hole	
12', 12a', 12b', 12c' first half hole	
12", 12a", 12b", 12c" second half hole	
13 rotating assembly	
13', 13a', 13b', 13c' first rotating member	
13", 13a", 13b", 13c" second rotating member	
131' first wire hole	131" second wire hole
2 coiling unit	3 wire
3a first wire	3a' first wire
3b second wire	3w twine portion
3x, 3x' extension	3y twine portion
3z, 3z' extension	31, 31a, 31a', 31b extension

-continued

Reference numbers of elements:	
32, 32' twine portion	33, 33a, 33a', 33b extension
34, 34' twine portion	35, 35a, 35a', 35b extension

DETAILED DESCRIPTION OF THE INVENTION

[0049] A method for knitting a net according to the present invention is used on a weaving machine identical to the weaving machine (see FIGS. 1-3) for carrying out the conventional method for knitting a net.

[0050] With reference to FIGS. 1-3, the weaving machine used in the present invention mainly includes a weaving unit 1. The weaving unit 1 includes a base assembly 11, a plurality of weaving holes 12, and a plurality of rotating assemblies 13. The base assembly 11 is comprised of a first base 11' and a second base 11". The first base 11' has a first abutment face 111' abutting a second abutment face 111" of the second base 11", allowing the first base 11' and the second base 11" to displace relative to each other along the first abutment face 111' and the second abutment face 111". The first base 11' and the second base 11" are driven by a power unit to proceed with the relative displacement.

[0051] Each weaving hole 12 is comprised of a first half hole 12' and a second half hole 12". The first half holes 12' are formed in the first abutment face 111' of the first base 11' at regular intervals. The second half holes 12" are formed in the second abutment face 111" of the second base 11" at regular intervals. Each first half hole 12' (12a', 12b', 12c') is aligned with one of the second half hole 12" (12a", 12b", 12c") to form a weaving hole 12.

[0052] Each rotating assembly 13 is rotatably received in one of the weaving holes 12. As an example, the rotating assemblies 13 are preferably driven by a driving member 14 to rotate. Each rotating assembly 13 includes two wire holes 131. Each rotating assembly 13 is comprised of a first rotating member 13' (13a', 13b', 13c') mounted on the first base 11' and a second rotating member 13" (13a", 13b", 13c") mounted on the second base 11" and aligned with the first rotating member 13', with the aligned first rotating member 13' and the second rotating member 13" jointly rotatable. Each first rotating member 13' has a first wire hole 131', and each second rotating member 13" has a second wire hole 131". Wires 3, 3a, 3b thread through the first and second wire holes 131' and 131". As an example, first wires 3a thread through the first wire holes 131', and second wires 3b thread through the second wire holes 131".

[0053] The weaving machine preferably includes a coiling unit 2 on a side of the weaving unit 1. The coiling unit 2 is driven by a power unit to coil a net formed after weaving.

[0054] With reference to FIG. 13, the method for knitting a net according to the present invention includes a wire threading step S1, a first misalignment step S2, a first rotation step S3, a second misalignment step S4, a second rotation step S5, and a repeating step S6.

[0055] With reference to FIGS. 1-3, in the wire threading step S1 of the present invention using the above weaving machine, a plurality of first wires 3a and a plurality of second wires 3b respectively thread through the first rotating members 13' and the second rotating members 13". Specifically, an end of each first wire 3a extends through the first wire hole 131' of one of the first rotating members 13'. An end of each

second wire 3b extends through the second wire 131" of the one of the second rotating members 13". The first wires 3a and the second wires 3b are pulled to extend away from the weaving unit 1. For example, in this embodiment, an end of each wire 3 (3a, 3b) is pulled and stretched by the coiling unit 2. In an example shown in FIG. 3, the relative position between the first base 11' and the second base 11" is defined as an initial state. In this state, the first rotating member 13a', 13b', and 13c' are respectively aligned with the second rotating members 13a", 13b", and 13c". Furthermore, the first rotating members 13a', 13b', and 13c' are respectively located in the first half holes 12a', 12b', and 12c'. The second rotating members 13a", 13b", and 13c" are respectively located in the second half holes 12a", 12b", and 12c". To assist in description hereinafter, the first wire 3a extending through the first wire hole 131' of the first rotating member 13a' is defined as wire 3a' and is represented by a bold line in FIG. 14.

[0056] With reference to FIGS. 3, 14, and 15, in the first misalignment step S2 of the present invention, the first base 11' and the second base 11" are controlled to displace from the initial state to a misaligned state, causing the first wires 3a and the second wires 3b to respectively extend in a first direction and a second direction to form extensions 31. Specifically, the first base 11' and the second base 11" respectively move along the first abutment face 111' and the second abutment face 111" to generate a misalignment displacement. As an example, the first base 11' displaces rightward, and the second base 11" displaces leftward, as shown in FIG. 15. Thus, the first rotating member 13a' displaces rightward until it aligns with an adjacent second rotating member 13b" to form a rotating assembly 13. Likewise, the first rotating member 13b' displaces rightward until it aligns with an adjacent second rotating member 13c" to form another rotating assembly 13. The rests undergo in the same manner. Thus, since the first rotation 13' is misaligned with the second rotating member 13" and since the wires 3 are continuously pulled by the coiling unit 2, the wires 3 will fork to form an extension 31a extending in a rightward direction (a first direction) and an extension 31b extending in a leftward direction (a second direction), as shown in FIG. 16. As an example, each first wire 3a' displaces rightward together with the corresponding first rotating member 13a' to form a rightwards extending extension 31a'. Each second wire 3b displaces leftward together with the corresponding second rotating member 13" to form a leftwards extending extension 31.

[0057] With reference to FIGS. 15-17, in the first rotation step S3 of the present invention, each rotating assembly 13 is rotated an odd number of half turns, causing the first wires 3a and the second wires 3b to intertwine with each other to form twine portions 32. Specifically, after the first misalignment step S2, the first rotating member 13a' and the second rotating member 13b" are respectively located in the first half hole 12a' and the second half hole 12b", as shown in FIG. 15. Then, the first rotation step S3 is carried out to rotate each rotating assembly 13 an odd number of half turns. As an example, the rotating assembly 13 comprised of the first rotating member 13a' and the second rotating member 13b" rotates 5 half turns (2.5 turns) in the counterclockwise direction. After rotation, the positions of the first rotating member 13a' and the second rotating member 13b" are exchanged such that the first rotating member 13a' and the second rotating member 13b" are respectively located in aligned second half hole 12b" and first half hole 12a'. Thus, in the misaligned state, the first rotating member 13' moves from the first half hole 12' in the first base

11' through an odd number of half turns to the second half hole 12'' in the second base 11'' aligned with the first half hole 12' in the first base 11'. By doing so, the extensions 31a and 31b generate a row of twine portions 32 and 32', as shown in FIG. 16.

[0058] With reference to FIGS. 17-19, in the second misalignment step S4 of the present invention, the first base 11' and the second base 11'' undergo misalignment displacement in the reverse direction to the initial state, causing the first wires 3a and the second wires 3b to respectively extend in the first direction and the second direction to form extensions 33a and 33b. Specifically, the initial state is restored by misalignment displacement in the reverse direction (moving first base 11' leftward and moving the second base 11'' rightward). Taking FIG. 19 as an example, the first rotating member 13a' displaces rightward together with the second base 11'' such that the first rotating member 13a' and another second rotating member 13c'' are respectively located in aligned first half hole 12b' and second half hole 12b''. Thus, the twine portions 32 extend rightward and leftward again to form a second layer of twine portions 33, as shown in FIG. 18. For example, the first wire 3a' again extends in the rightward direction (the first direction) after the twine portion 32' to form the extension 33a'. The second wire 3b again extends in the leftward direction (the second direction) after the twine portion 32 to form the extension 33b.

[0059] With reference to FIGS. 19-21, in the second rotation step S5 of the present invention, each rotating assembly 13 is rotated an odd number of half turns, causing the first wires 3a and the second wires 3b to intertwine with each other to form twine portions 34. Specifically, after the second misalignment step S4, the first rotating member 13a' and the second rotating member 13c'' are respectively located in the second half hole 12b'' and the first half hole 12b', as shown in FIG. 19. Next, the second rotation step S5 is carried out to rotate each rotating assembly 13 an odd number of half turns. As an example, the rotating assembly 13 comprised of the first rotating member 13a' and the second rotating member 13c'' rotates 5 half turns (2.5 turns) in the clockwise direction. After rotation, the positions of the first rotating member 13a' and the second rotating member 13c'' are exchanged such that the first rotating member 13a' and the second rotating member 13c'' are respectively located in aligned first half hole 12b' and second half hole 12b''. Thus, in the aligned state, the first rotating member 13' moves from the second half hole 12'' in the second base 11'' through an odd number of half turns to the first half hole 12' in the first base 11' aligned with the second half hole 12'' in the second base 11''. By doing so, the extensions 33a and 33b generate a row of twine portions 34 and 34', as shown in FIG. 20. Furthermore, in this embodiment, the rotating direction of the rotating assemblies 13 in the first rotation step S3 can be the same as or opposite to the rotating direction of the rotating assemblies 13 in the second rotation step S5. Preferably, the rotating direction in the first rotation step S3 is opposite to that in the second rotation step S5. A net having enhanced structural strength can be obtained by intertwining the wires 3 through rotations in opposite directions.

[0060] With reference to FIGS. 21-23, in the repeating step S6 of the present invention, the first misalignment step S2 is repeated until the woven net reaches a predetermined size. Specifically, the first misalignment step S1 is carried out again (see FIG. 23) to obtain another layer of extensions 35, 35a, 35a', 35b, as shown in FIG. 22. By repeating the first misalignment step S2 through the second rotation step S5, the

first wire 3a extending through the first wire holes 131' will gradually extend leftward, obtaining a net by slant cross weaving of wires 3a and 3b, as shown in FIG. 22.

[0061] With reference to FIG. 24, even a rightwards extending first wire 3a in the net formed by the method for knitting a net according to the present invention is broken, the structure of the net is still maintained by several leftwards extending wires 3b, because the net is formed by cross weaving. Thus, the maximal size of the hole in the net is only two meshes. Large holes will not occur. Thus, the overall structural strength of the net is increased.

[0062] In view of the foregoing, by moving the first base 11' and the second base 11'' to the misaligned state, rotating each rotating assembly 13 an odd number of half turns to exchange the positions of the first rotating member 13' and the second rotating member 13'' in the same weaving hole 12, moving the first base 11' and the second base 11'' back to the initial state, rotating each rotating assembly 13 an odd number of half turns again, etc., the first rotating member 13' and the second rotating member 13'' continuously move rightward and leftward to weave the net having high structural strength. Thus, the present invention can actually increase the structural strength of the net.

[0063] With reference to FIG. 25, in the method for knitting a net according to the present invention, after the wire threading step S1, the first rotation step S3 can be carried out and then the first misalignment step S2. Next, the second rotation step S5 is carried out and then the second misalignment step S4. The steps are identical to the above steps and, therefore, not redundantly described. After repeating these steps, the above net formed by cross weaving can be obtained. Thus, the method for knitting a net according to the present invention is not limited to firstly carry out the first misalignment step S2 or the first rotation step S3. Only alternate proceeding of the rotation step of rotating an odd number of half turns and the misalignment step is required.

[0064] In the method for knitting a net according to the present invention, each of the first wire and the second wire moves in a predetermined direction and is continuously cross woven with another wire. Thus, even if a wire of the net woven by the present invention is broken, several wires extending in the other direction can still maintain the structure of the net, because the net is formed by cross weaving such that the maximal size of the hole in the net is only two meshes. Large holes will not occur. Thus, the present invention provides an effect of avoiding generation of large holes.

[0065] Furthermore, since the net formed by the method according to the present invention can avoid large holes, the present invention can increase the overall structural strength of the net.

What is claimed is:

1. A method for knitting a net characterized by comprising:
 - a wire threading step including threading each of a plurality of first wires through a first rotating member and threading each of a plurality of second wires through a second rotating member;
 - a first misalignment step including controlling a first base and a second base to displace from an initial state to a misaligned state, causing the plurality of first wires and the plurality of second wires to respectively extend in a first direction and a second direction to form extensions;
 - a first rotation step including jointly rotating the first rotating members and the second rotating members an odd number of half turns, causing the plurality of first wires

and the plurality of second wires to intertwine with each other to form twine portions;

a second misalignment step including displacing the first base and the second base from the misaligned state to the initial state, causing the plurality of first wires and the plurality of second wires to respectively extend in the first direction and the second direction to form extensions;

a second rotation step including jointly rotating the first rotating members and the second rotating members an odd number of half turns, causing the plurality of first wires and the plurality of second wires to intertwine with each other to form twine portions; and

a repeating step including repeating the first misalignment step through the second rotation step until a net formed by the extensions and the twine portions reaches a predetermined size.

2. The method for knitting a net as claimed in claim 1, characterized in that weaving is carried out in a sequence of the wire threading step, the first misalignment step, the first rotation step, the second misalignment step, the second rotation step, and the repeating step.

3. The method for knitting a net as claimed in claim 1, characterized in that weaving is carried out in a sequence of the wire threading step, the first rotation step, the first misalignment step, the second rotation step, the second misalignment step, and the repeating step.

4. The method for knitting a net as claimed in claim 1, characterized in that an end of each of the plurality of first wires and an end of each of the plurality of second wires are pulled away from the first base and the second base.

5. The method for knitting a net as claimed in claim 1, characterized in that in the second misalignment step, the first base and the second base undergo misalignment displacement in misalignment directions reverse to the first misalignment back to the initial state.

6. The method for knitting a net as claimed in claim 1, characterized in that a rotating direction in the first rotation step is same as a rotating direction in the second rotation step.

7. The method for knitting a net as claimed in claim 1, characterized in that a rotating direction in the first rotation step is opposite to a rotating direction in the second rotation step.

* * * * *