

*I. W. Snyder,*

*Water Wheel.*

*No. 108529.*

*Patented Oct. 18. 1870.*

*Fig. 2.*

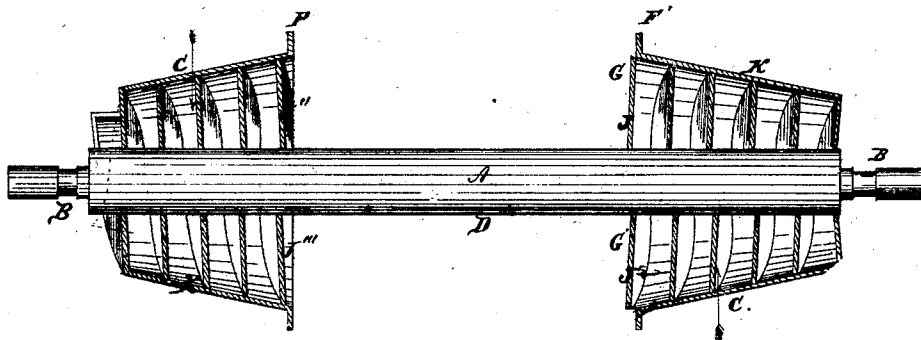

*Fig. 1.*

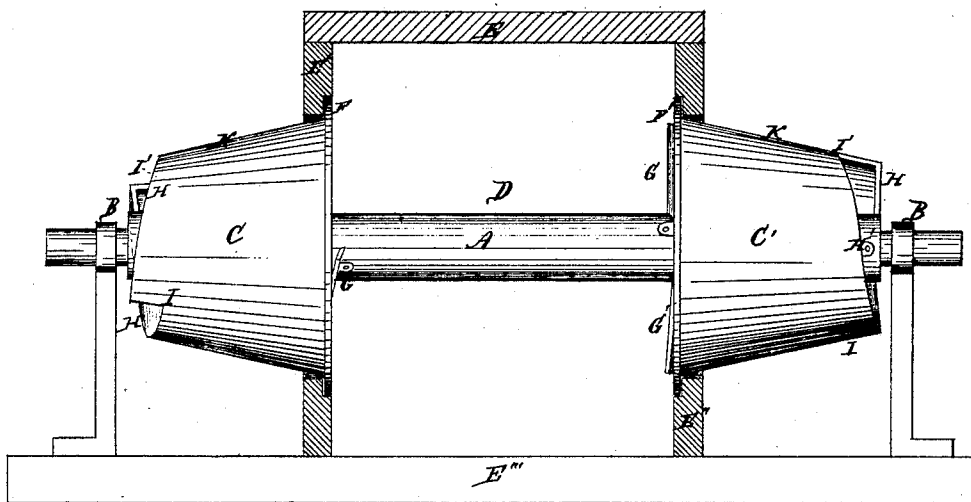

*Witnesses.*

*G. J. Parker  
A. C. Coy*

*Inventor.*

*Ira. W. Snyder*

# United States Patent Office.

IRA W. SNYDER, OF DRYDEN, NEW YORK.

Letters Patent No. 108,529, dated October 18, 1870.

## IMPROVEMENT IN WATER-WHEELS.

The Schedule referred to in these Letters Patent and making part of the same.

### *To all whom it may concern:*

Be it known that I, IRA W. SNYDER, of the town of Dryden, Tompkins county, New York, have invented an improved Water-Wheel, of which the following is a specification.

My object is to make an efficient wheel, and my invention relates more particularly to the manner of doing this, as will be seen as I describe it.

Figure 1 is a view of my wheel, and of the flume that leads the water to it, the flume being in section.

Figure 2 is a section of the wheel and axle, showing the scrolls of the internal portion of the wheel.

In fig. 1—

A is the axle, supported by the bearings B and B', and

C C' are two wheels, made alike in principle, but with reversed internal scrolls, having the space D for the water to enter each, confined by the flume E E' E'' E''', which is in part represented as cut away, to show the tightening-flanges F F' of the wheels.

The mouths G G' of the wheels are larger than the vents H H', so that the wheels, as shown, taper toward the vents.

The vents are also cut away at I I', to the incline of the spiral partitions or scrolls.

In fig. 2, the same letters show the same parts; but the main design of this figure is to show the arrangement of the spiral partitions or scrolls, and J is one partition, and J' the other, of the right-hand wheel C, and J'' with J''' show the two partitions of the left-hand wheel.

These spiral partitions are plain and parallel to each other from mouth to vent, and a perpendicular line through them, as by the arrow, is seen to be at right angles to the axis or shaft, to which they are fastened as they are to the shell or outer case, K, of the wheel, the lessening of the size of the vents from the mouth being mainly by the tapering of the shell K.

The uses and advantages of my invention are apparent to those skilled in the art to which it appertains.

### *Claims.*

1. The wheel C, with two or more partitions J J', parallel to each other, and making two or more spiral scrolls, with two or more complete circuits about the axis of the wheel, as described.

2. The outer case K, over the partitions J J', making two spiral chambers in the wheel, and the said case tapering from the mouth to the vents of the wheel, as described.

3. The combined whole, consisting of the shaft A, the flume E, tapering shell K, two spiral scrolls J J', the spiral chambers made by the case and the partitions, the gathering-lips G G', and open vents I I', arranged and operating as set forth.

IRA W. SNYDER.

Witnesses:

S. J. PARKER,  
J. E. COY.