

(19) **DANMARK**

(10) **DK/EP 3225145 T3**



Patent- og
Varemærkestyrelsen

(12) **Oversættelse af
europæisk patentskrift**

-
- (51) Int.Cl.: **A 47 L 9/02 (2006.01)** **A 47 L 9/00 (2006.01)** **A 47 L 9/24 (2006.01)**
- (45) Oversættelsen bekendtgjort den: **2019-08-12**
- (80) Dato for Den Europæiske Patentmyndigheds bekendtgørelse om meddelelse af patentet: **2019-05-22**
- (86) Europæisk ansøgning nr.: **17162714.4**
- (86) Europæisk indleveringsdag: **2017-03-24**
- (87) Den europæiske ansøgnings publiceringsdag: **2017-10-04**
- (30) Prioritet: **2016-03-31 IT UA20162159**
- (84) Designerede stater: **AL AT BE BG CH CY CZ DE DK EE ES FI FR GB GR HR HU IE IS IT LI LT LU LV MC MK MT NL NO PL PT RO RS SE SI SK SM TR**
- (73) Patenthaver: **New Ermes Europe S.r.l., Via Risorgimento, 19, 21020 Crosio della Valle (VA), Italien**
- (72) Opfinder: **Roschi, Riccardo, c/o NEW ERMES EUROPE S.r.l., Via Risorgimento, 19, 21020 Crosio della Valle (VA), Italien**
- (74) Fuldmægtig i Danmark: **Patrade A/S, Ceresbyen 75, 8000 Århus C, Danmark**
- (54) Benævnelse: **Sugehoved med forbedret sugekanal**
- (56) Fremdragne publikationer:
EP-A1- 1 367 931
EP-A2- 1 674 012
DE-C1- 19 704 796
DE-U1- 8 901 995
FR-A1- 2 417 285

DESCRIPTION

BACKGROUND

[0001] The present invention relates to a suction head to be fitted to an electric household appliance for performing cleaning by means of suction, such as a vacuum cleaner, an electric broom, a multi-purpose vacuum cleaner drum or a vacuum cleaner robot, for sucking up dust and/or fluids and/or dirt from a surface. In particular, the present invention relates to a suction head with an improved suction channel, substantially without narrow zones.

STATE OF THE ART

[0002] As is known, a vacuum cleaner, an electric broom or a similar electric household appliance for performing cleaning by means of suction comprises a suction head for sucking up dust, dirt or fluids from a surface. In the sector of electric household appliances, a suction head is generally referred to by the term "brush". For the purpose of the present description, therefore, the terms "suction head" and "brush" are considered to be equivalent. Again for the purpose of the present invention, the term "vacuum cleaner" will be used with a broad meaning so as to include all those apparatus, for professional or domestic use, which perform cleaning by means of suction. Therefore, the term "vacuum cleaner" will comprise a vacuum cleaner, an electric broom, a so-called multi-purpose vacuum cleaner drum, a vacuum cleaner robot, a centralized suction system for domestic or industrial use and an apparatus for supplying and sucking in steam.

[0003] Basically a known suction head comprises a base plate shaped so as to have at least one base plate channel open towards a surface to be vacuumed, a suction channel in fluid communication with the base plate and optionally a covering body. The covering body can be engaged with the base plate, the suction channel or both of them. The other end of the suction channel communicates with a suction tube.

[0004] A suction head is known, for example, from EP 2 944 242 and EP 1 600 091 in the name of the same Applicant.

[0005] EP 1 367 931 A1 discloses a tilting joint in a vacuum cleaner suction channel.

[0006] DE 89 01 995 U1 discloses a vacuum cleaner.

[0007] In the present description and the claims the expression "suction efficiency" will be understood as meaning essentially the ratio, in percentage terms, of the vacuumed material to the material to be vacuumed. The vacuuming tests are carried out in accordance with the provisions of the standard EN 60312-1:2013-05.

[0008] Although various suction heads which perform the function of sucking dust and/or fluids and/or dirt from a surface in a sufficiently efficient manner are available on the market, the Applicant has noticed that there exists the need to improve the performance of the known suction heads. In particular, the Applicant has noticed the need to increase the efficiency for suction of dust and dirt from a surface.

SUMMARY OF THE INVENTION

[0009] The Applicant has carefully considered the cross-section of the suction channel and has noted that in the known solutions there are discontinuous and/or narrow zones which prevent a regular suction flow. Owing to these discontinuous zones and significant variations in cross-section, the vacuuming efficiency is significantly reduced compared to that which can be obtained depending on the power of the motor.

[0010] Another problem consists in the fact that these discontinuous zones and variations in cross-section create more noise which is not tolerated by users.

[0011] The Applicant has discovered that, in order to keep the cross-section of the suction channel substantially constant, the suction channel may be shaped with a first fixed portion with a longitudinal axis which follows a circle arc and a second portion, also with a longitudinal axis, which follows a circle arc and is telescopically movable with respect to the fixed portion.

[0012] The invention relates to a suction head for a vacuum cleaner or the like, comprising:

- a base plate) with a base plate channel open towards a surface to be vacuumed,
- a suction channel in fluid communication with the base plate channel, wherein said suction channel comprises an inner tube and an outer tube, wherein the inner tube is fixed to the base plate channel and the outer tube is rotatable telescopically with respect to the inner tube,
- a bushing fixed to said outer tube and a pivot pin, wherein said outer tube is rotatable about an axis of rotation of the pivot pin,
- an axle and wheels mounted at the ends of said axle for moving said suction head on the surface to be vacuumed, wherein said pivot pin of the outer tube is arranged in front of the axle, and
- two arms with first holes for the pivot pin and second holes for the axle of the wheels.

[0013] The outer tube may comprise a first part with a longitudinal axis which follows a circumference portion.

[0014] The first part of the outer tube could have a substantially circular cross-section measured along a plane perpendicular to said longitudinal axis.

[0015] The inner tube could comprise a first part that receives fluid and a second part, wherein said second part of the inner tube has an outer surface substantially corresponding to an inner surface of the first part of the outer tube.

[0016] The inner tube could terminate with a sealing lip.

[0017] The outer tube could comprise a second part having a reduced wall thickness and a circular notch for rotatably engaging an end edge of a joint.

[0018] The base plate channel could comprise a front edge and a rear edge, wherein at least the surface of the lower face which extends along the front edge of the base plate channel and at least the surface of the lower face which extends along the rear edge of the base plate channel lie on a same plane.

BRIEF DESCRIPTION OF THE DRAWINGS

[0019] The present invention will become clearer from the following detailed description, provided purely by way of a non-limiting example, to be read with reference to the accompanying drawings, in which:

- Figure 1 shows a schematic cross-sectional view of a suction head according to an embodiment of the present invention in a first configuration;
- Figure 2 shows a schematic cross-sectional view of a suction head according to an embodiment of the present invention in a second configuration;
- Figure 3 shows a plan view of a base plate of the suction head shown in Figures 1 and 2;
- Figures 3A, 3B, 3C, 3D and 3E are cross-sections along the respective lines A-A of Figure 3;
- Figure 4 is a schematic view, from above, of the suction duct according to an embodiment of the invention;
- Figures 4A, 4B and 4C are cross-sections through the suction duct along the lines A, B and C in Figure 4;
- Figure 5 shows the suction channel partially disassembled;
- Figure 6 is a view, on larger scale, of a part of Figure 5;
- Figure 7 is a schematic cross-sectional view of the suction channel of the suction head according to Figures 1 and 2;
- Figures 8.1 and 8.2 show in schematic form, separately, the inner tube and the outer tube of the suction channel; and
- Figure 9 shows in schematic form an embodiment of engagement between the suction channel and the joint.

DESCRIPTION OF EMBODIMENTS

[0020] In the various figures, for the sake of clarity some components not considered essential for the present invention have been omitted. In particular, the pedal and the associated control mechanism for moving a bristled support or a rubber fin which could be present in some embodiments are not shown. The suction head is denoted overall by the reference number 1.

[0021] In the present description a number of expressions will be used with reference to the air flow during suction. For example, the term "inlet" of a certain component indicates a section, an area, a zone or a point where the suction air enters into the component when the suction head is mounted on a vacuum cleaner and this is in use. Similarly, the term "outlet" of a certain component indicates a section, an area, a zone or a point where the suction air exits the component when the suction head is mounted on a vacuum cleaner and this is in use.

[0022] The relative terms "lower" and "upper" relate to the suction head in its operating configuration, namely when resting on a surface to be vacuumed.

[0023] Finally, the terms "front" and "rear" relate to the suction head in its configuration for use: "front" indicates a component which is situated or directed in the direction of advancing movement of the suction head and "rear" indicates a component which is situated or directed in the return direction.

[0024] With reference to the various figures, the suction head 1 comprises a base plate 2 with at least one base plate channel 3 open downwards, namely towards a surface to be vacuumed. The suction head 1 comprises also a curved and suitably shaped suction channel 4 and a rotatable joint 5 rotating about an axis 6. The assembly consisting of the base plate channel 3, the suction channel 4 and the joint 5 forms the suction duct 7.

[0025] Figure 3 shows a plan view of an embodiment of the base plate 2 of the suction head according to Figures 1 and 2. Figures 3A-3E are cross-sections along the respective lines A-E of Figure 3.

[0026] According to the embodiment shown in Figures 3, the base plate comprises a channel 3 of the base plate 2 which extends substantially over the entire width of the suction head. Preferably, the channel 3 has a substantially constant width, apart from the end portions where it is narrower.

[0027] At the ends, the channel 3 has a smaller depth (Figure 3E). The base plate channel increases in depth towards the centre (Figures 3A-3C). In the centre (Figure 3D), the base plate channel opens out so that it can connect to the suction channel 4.

[0028] The front edge of the channel 3 is identified by the reference number 31 and the rear

edge of the channel is identified by the reference number 32. The surface of the base plate in the vicinity of the front edge 31 is substantially flat and horizontal. Similarly, the surface of the base plate close to the rear edge 32 is substantially flat and horizontal.

[0029] Preferably, in the central zone of the base plate, there are two strips of velvet 36 or the like, a front strip and a rear strip. The strips 36 may be inset in special suitably shaped cavities (shown in the cross-sections of Figures 3C and 3D).

[0030] The suction channel 4 is in fluid communication with the channel 3 of the base plate 2. The suction channel 4 according to the present invention comprises a first portion 41 and a second portion 42. The first portion is also called "inner tube" 41 and the second portion is also called "outer tube" 42.

[0031] Preferably, the inner tube 41 of the suction channel 4 is connected to the base plate channel 3 via any known connection means. For example, the connection may be of the press-engaging type or a fixing system with screws or rivets. Alternatively, the inner tube 41 of the suction channel 4 may be connected to the base plate 2 and to the base plate channel 3 by means of welding (for example ultrasound) or by means of gluing with adhesive. By way of a further alternative, the inner tube 41 of the suction channel 4 may be formed as one piece with the base plate 2 and therefore with the base plate channel 3.

[0032] The inner tube 41 of the suction channel 4 comprises a first connecting part 41a and a second part 41b, the outer surface of which follows a curved tubular section. Preferably, the curved tubular section has a longitudinal axis 41c which follows a circle arc. Preferably, the outer cross-section of the inner tube 41 (except for its first part 41a which is connected to the base plate channel 3) is substantially circular. By way of a non-limiting example, the cross-section of the suction channel along its second part 41b could have an inner diameter of about 30-55 mm. Preferably, the cross-sectional area of the inner tube 41 of the suction channel widens from the inlet towards the outlet and does not have narrow and/or discontinuous zones.

[0033] Preferably, the outlet edge of the inner tube 41 of the suction channel 4 terminates with a sealing lip 44. The sealing lip 44 ensures a gentle transition between the inner tube and the outer tube 42 (which will be described here below) of the suction channel 4. As an alternative to the sealing lip 44 a gasket and/or O-ring made of rubber, plastic, Teflon or the like could be provided.

[0034] In order to ensure that the outer surface of the inner tube 41 has a circular cross-section with the axis 41c which follows a circle portion, it may be envisaged suitably shaping the outer surface of the inner tube 41 without modifying the internal cross-section of the inner tube 41. Figure 8.1 shows the inner tube separate from the outer tube and shows the surface 41d which forms a surface suitable for the rotating telescopic movement with the outer tube 42. As can be seen from Figure 8.1, the internal cross-section of the inner tube 41, also along the surface 41d, has a progression which is regular and increases towards the outlet end of the inner tube 41.

[0035] Preferably, the inner tube 41 comprises a stop 45 for limiting the movement of the outer tube 42 with respect to the inner tube 41. The stop 45 is shown in Figure 1 and Figure 8.1. Figure 2 shows the outer tube 42 in its end-of-travel position, with the edge against the stop 45. In the position shown in Figure 1, the end portion of the joint 5 may be inclined at an angle α of about 40° . In the position shown in Figure 2, the end portion of the joint 5 may be inclined at an angle α of about 70° . Preferred values of α are, respectively, 41° and 73° .

[0036] The outer tube 42 of the suction channel 4 is associated with the inner tube 41 telescopically so that the inner surface of the outer tube 42 cooperates with the outer surface of the inner tube 41. This telescopic cooperation is shown in Figures 1 and 2 which show two different positions of the inner tube 41 with respect to the outer tube 42.

[0037] Preferably, therefore, the outer tube 42 comprises a first part 42a shaped with a curved tubular section, which is preferably substantially circular, and a second connecting part 42b. The curved tubular section is shaped so as to have a longitudinal axis 42c which follows a circle arc. When the inner tube 41 is telescopically associated with the outer tube 42, the longitudinal axis 41c of the inner tube 41 which follows a circle arc substantially coincides with (or forms an extension of) of the longitudinal axis 42c of the outer tube 42 which follows a circle arc.

[0038] As mentioned above, the inner tube 41 of the suction channel 4 terminates with a sealing lip 44 for providing a fluid-tight seal between the inner tube 41 and the outer tube 42. Preferably, the lip 44 narrows towards the outlet in order to ensure a gentle transition between the two components.

[0039] As mentioned above, the inner tube 41 of the inlet channel 4 is fixed, while the outer tube 42 is rotatable and is telescopically associated with the inner tube 41. As a result of this telescopic connection, the inner tube 41 always remains, at least partially, inside the outer tube 42.

[0040] With reference to Figures 4, 5 and 6, the articulation which allows the relative rotational movement of the outer tube and the inner tube will now be described.

[0041] The outer tube 42 preferably comprises a bushing 46 with a hole 47 for a pin 48. The bushing 46 is fixed to the outer tube 42 along its bottom part. The axis 48' of the bushing corresponds to the axis of rotation of the outer tube 42.

[0042] A pair of arms 9 are fixed to the base plate 2 and/or to the inner tube 41 and extend projecting towards the outer tube 42 and the rear part of the suction head 1. The arms 9 may be solid or light-weight as shown in Figure 5.

[0043] Two holes 91 and 92 for each arm are provided in the vicinity of the free ends of the arms 9. The holes 91 are designed to cooperate with and rotatably support the pin 48. The

bushing 46 has a length corresponding to the distance between the two facing walls of the arms 9. Therefore, when the inner tube and the outer tube are joined together telescopically, the pin 48 will be inserted inside the holes 91 of the arms 9 and inside the hole 47 of the bushing 46. Figure 7 illustrates in schematic form the relative rotational movement of the outer tube 42 and the inner tube 41.

[0044] The holes 92 are configured to support rotatably an axle 81 for the wheels 8.

[0045] Preferably, the axle 82 of the wheels 8 is situated at the rear with respect to the axis 48' for relative rotation of the outer tube and inner tube.

[0046] With reference now to the figures, and in particular to Figures 1, 2, 4 and 9, the joint 5 and the rotatable connection with respect to the suction channel 4 will now be described.

[0047] The second part 42b of the outer tube 42 of the suction channel 4 is preferably circular and operates as a connection for the rotatable joint 5.

[0048] Figure 9 shows, by way of example, how the rotatable joint 5 is connected together with the outer tube 42 of the suction channel 4. In particular, a snap-engaging connection may be envisaged between a tooth 512 formed on the circular edge of the joint 5 and a corresponding incision 49 formed in the outer surface of the second part 42b of the outer tube 42 of the suction channel 4. Preferably, in the connection zone (as shown in Figure 9), the thickness of the wall of the joint 5 and that of the outer tube 42 is reduced so that overall the thickness remains substantially unchanged.

[0049] The angled joint 5 may rotate with respect to the outer tube 42 of the suction duct 4. The rotation takes place about the axis 6 of the second portion 42b of the outer tube 4.

[0050] Therefore the angled joint 5 may perform two rotations. A first rotation with respect to the axis of rotation 48' of the outer tube 42 and a second rotation with respect to the longitudinal axis 6 of the outlet part of the outer tube 42. The first rotation is a rotation in a plane, preferably a plane substantially perpendicular to the plane to be vacuumed and in which the suction head 1 moves.

[0051] A rigid or flexible tube (not shown) may be connected to the outlet end of the joint 5. As an alternative to the angled joint 5 shown in Figures 1 and 2, any other joint which is straight, differently angled, rigid or flexible, may be associated with the outer tube 42 of the suction channel 4.

[0052] A brush body 10 may be fixed to one or more of the base plate 2, the inner tube 41 of the suction channel 4 or the outer tube 42 of the suction channel 4. The suction head may also comprise a cover 11.

[0053] As can be seen from Figures 1 and 2, both in the configuration shown in Figure 1 and

in the configuration shown in Figure 2, the air flow from the base plate channel 3 to the suction channel 4 and the joint 5 does not have major discontinuous or narrow zones. This is due to the novel telescopic relationship between the two portions 41, 42 of the suction channel 4, in which the first portion 41 (that which receives air from the base plate channel 3) forms the inner tube 41 and is fixed with respect to the base plate 2, while the second portion 42 forms the outer tube. The outer tube 42 has preferably a circular cross-section and an axis 42c which follows a circle arc. Between the inner tube 41 and the outer tube 42 there is a sealing lip 44 for ensuring a gentle transition between the two tubes 41, 42 and for ensuring a fluid-tight seal and minimizing leakages.

REFERENCES CITED IN THE DESCRIPTION

This list of references cited by the applicant is for the reader's convenience only. It does not form part of the European patent document. Even though great care has been taken in compiling the references, errors or omissions cannot be excluded and the EPO disclaims all liability in this regard.

Patent documents cited in the description

- [EP2944242A \[0004\]](#)
- [EP1600091A \[0004\]](#)
- [EP1367931A1 \[0005\]](#)
- [DE8901995U1 \[0006\]](#)

PATENTKRAV

1. Sugehoved (1) til en støvsuger eller lignende omfattende:

- 5
- en bundplade (2) med en bundpladekanal (3) åben mod en overflade, der skal støvsuges,
 - en sugekanal (4) i fluidforbindelse med bundpladekanal (3),

hvor nævnte sugekanal (4) omfatter et indre rør (41) og et ydre rør (42),

10 hvor det indre rør (41) er fastgjort til bundpladekanal (3), og det ydre rør (42) er roterbart teleskopisk i forhold til det indre rør (41),

- en bøsning (46) fastgjort til nævnte ydre rør og en drejetap (48), hvor nævnte ydre rør (42) er roterbart omkring en rotationsakse (48') af drejetappen (48),
- 15 - en aksel (81) og hjul (8) monteret ved enderne af nævnte aksel (81) til at bevæge nævnte sugehoved (1) på overfladen, der skal støvsuges,

hvor det ydre rørs (42) nævnte drejetap (48) er anbragt foran akslen (81) og

- 20
- to arme (9) med første huller (91) for drejetappen (48) og andet huller (92) for hjulenes aksel (81).

2. Sugehoved (1) ifølge krav 1, hvor nævnte ydre rør (42) omfatter en første del (42a) med en længdeakse (42c), der følger en omkredsdel.

25

3. Sugehoved (1) ifølge krav 2, hvor nævnte første del (42a) af det ydre rør (42) har et i det væsentlige cirkulært tværsnit målt langs et plan vinkelret på nævnte længdeakse (42c).

30

4. Sugehoved (1) ifølge krav 3, hvor nævnte indre rør (41) omfatter en første del (41a), som modtager fluid og en anden del (41b), hvor nævnte anden del (41b) af det indre rør (41) har en ydre overflade i det væsentlige svarende til en indre overflade af den første del (42a) af det ydre rør (42).

5. Sugehoved (1) ifølge krav 3, hvor nævnte indre rør (41) ender med en tætningslæbe (44).

5 6. Sugehoved (1) ifølge krav 1, hvor nævnte ydre rør (42) omfatter en anden del (42b) med en reduceret vægtykkelse og et cirkulært hak (49) til roterbart indgreb med en endekant (51) af en forbindelse (5).

10 7. Sugehoved (1) ifølge krav 1, hvor bundpladekanalen (3) omfatter en forkant (31) og en bagkant (32), hvor i det mindste overfladen af den nedre flade, der strækker sig langs forkanten (31) af bundpladekanalen (3) og i det mindste overfladen af den nedre flade, der strækker sig langs bundkanalens (3) bagkant (32) ligger i samme plan.

DRAWINGS

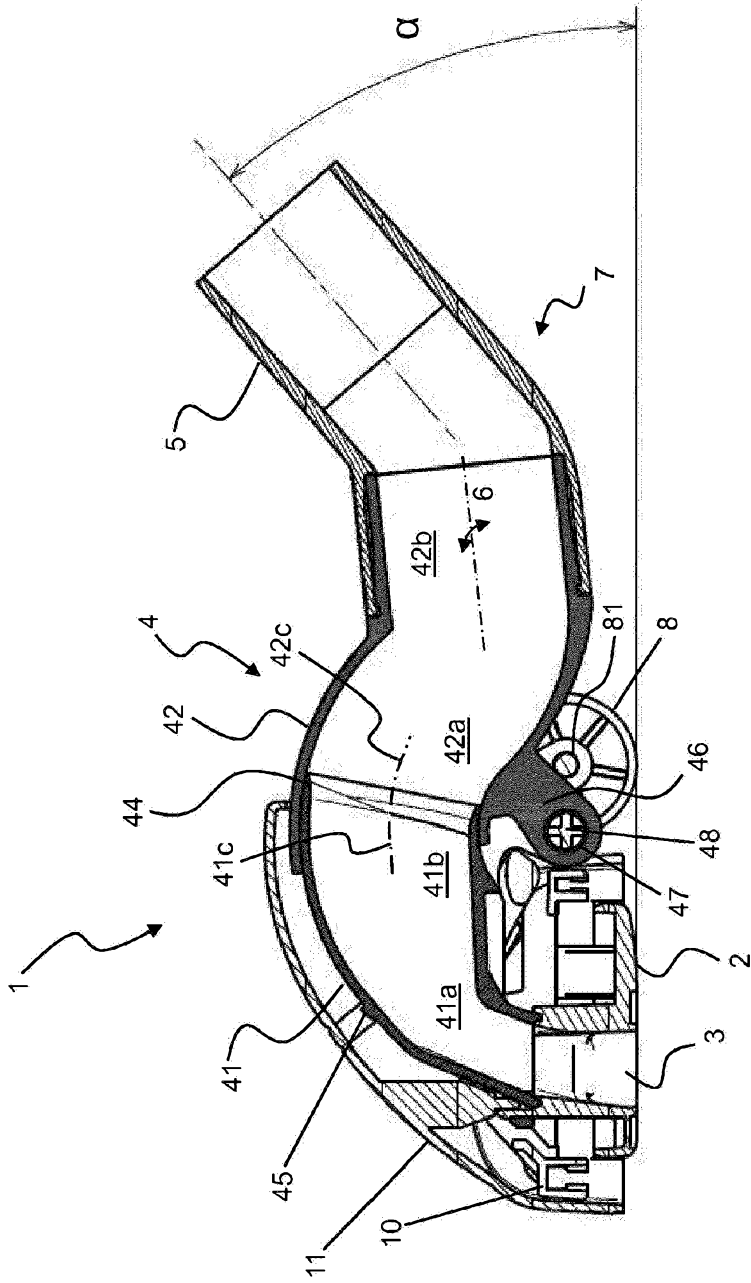

Fig. 1

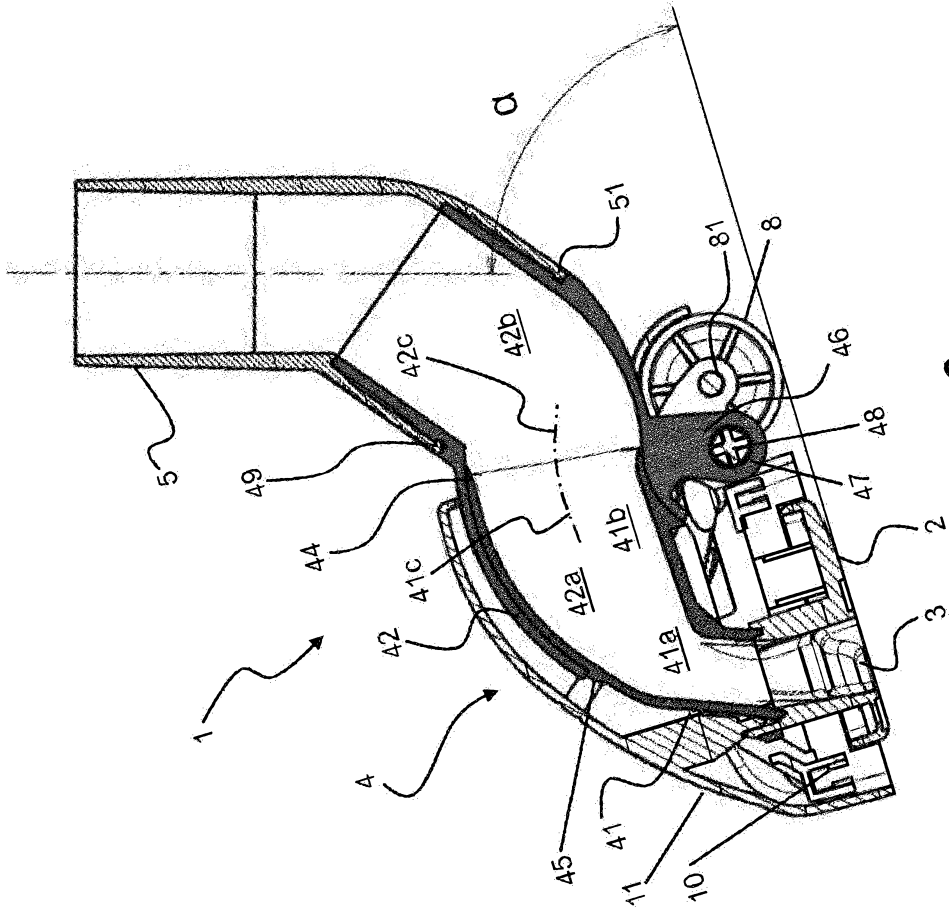

Fig. 2

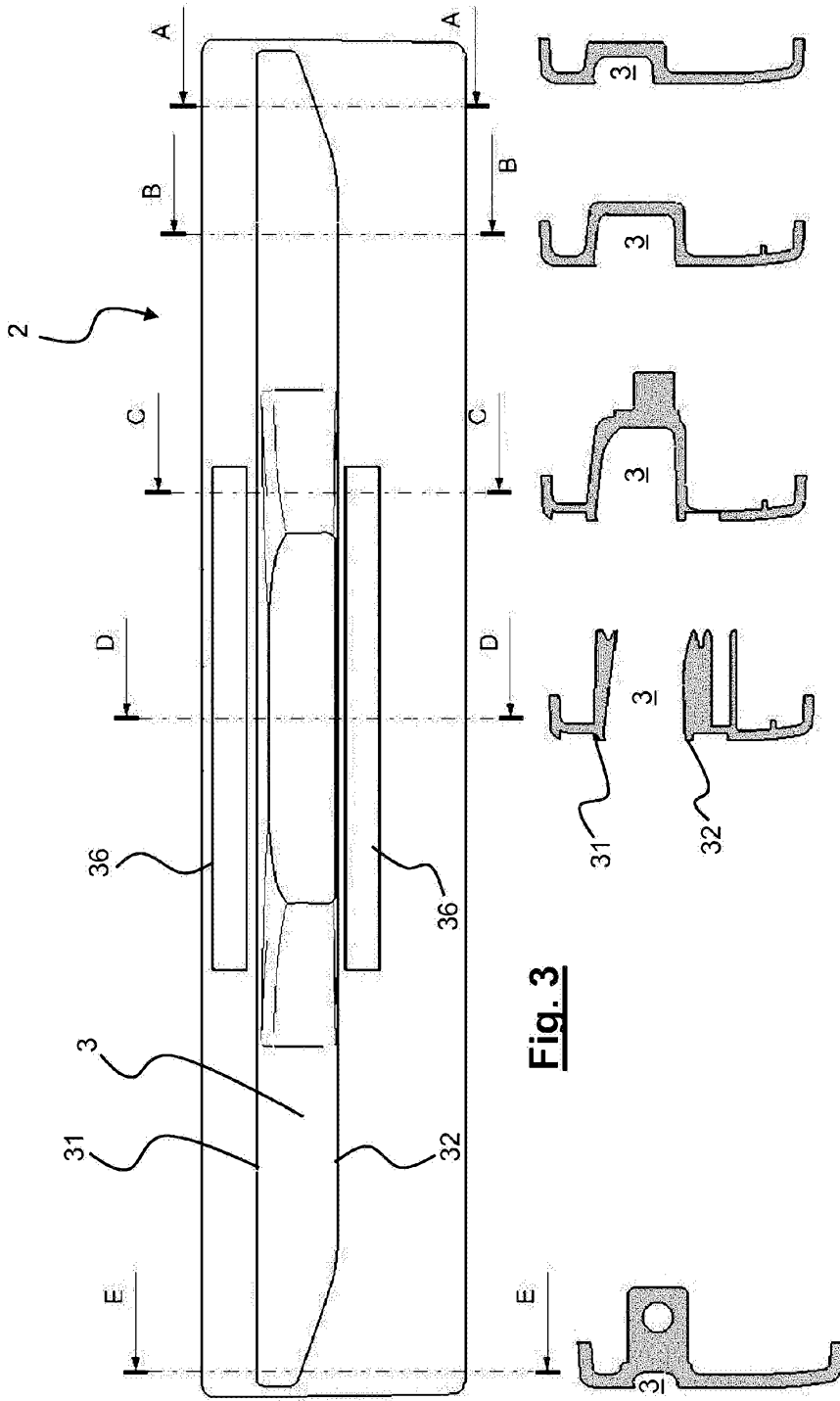

Fig. 3

Fig. 3A

Fig. 3B

Fig. 3C

Fig. 3D

Fig. 3E

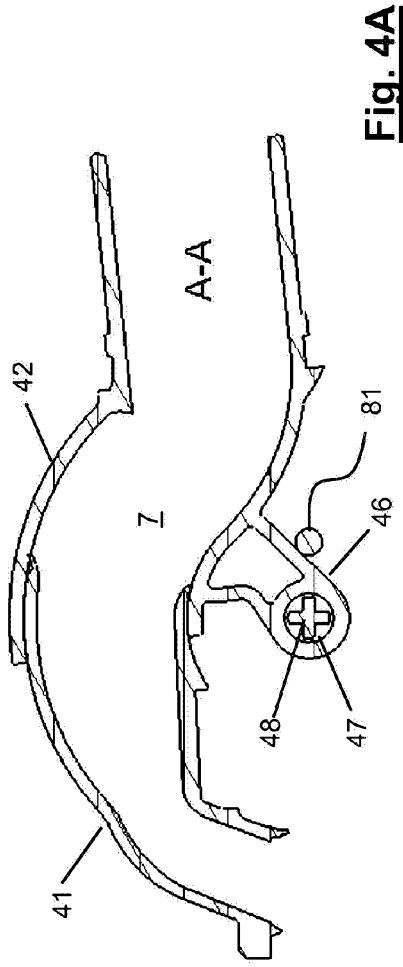

Fig. 4A

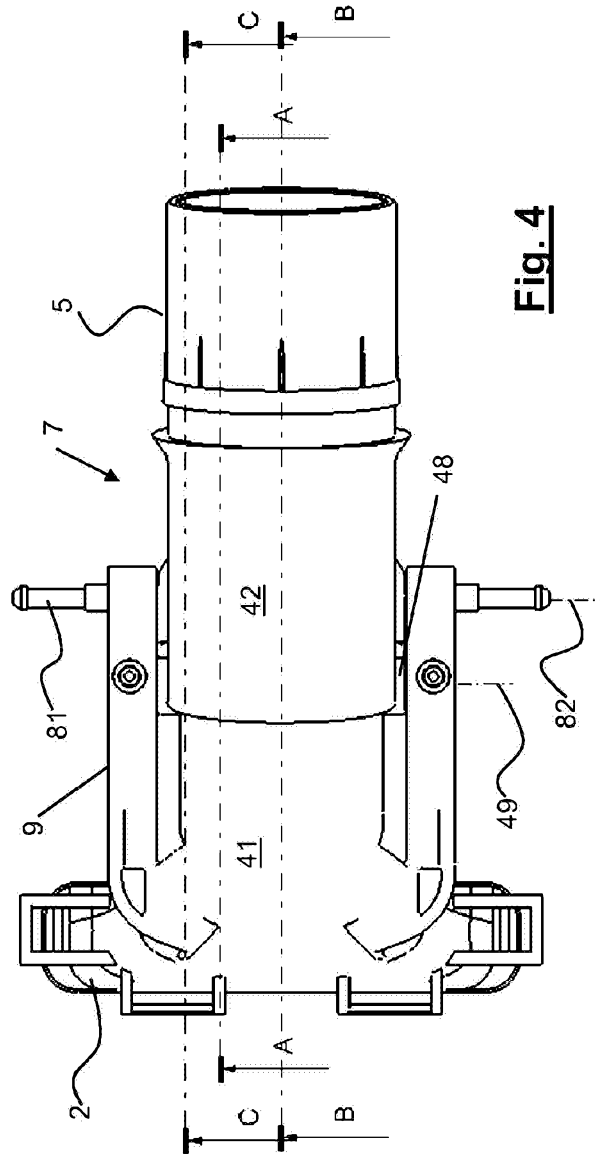

Fig. 4

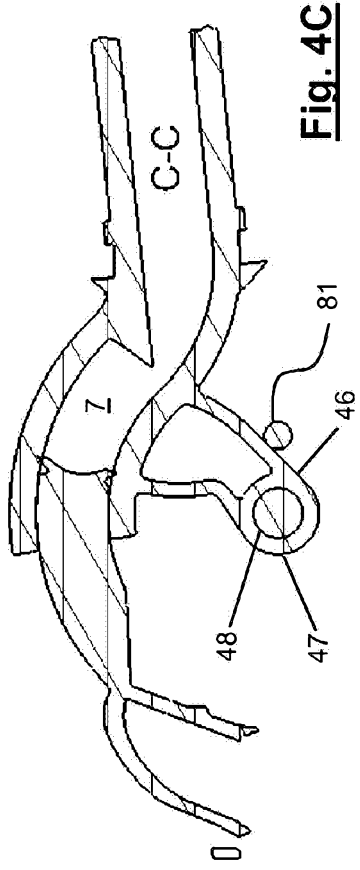

Fig. 4C

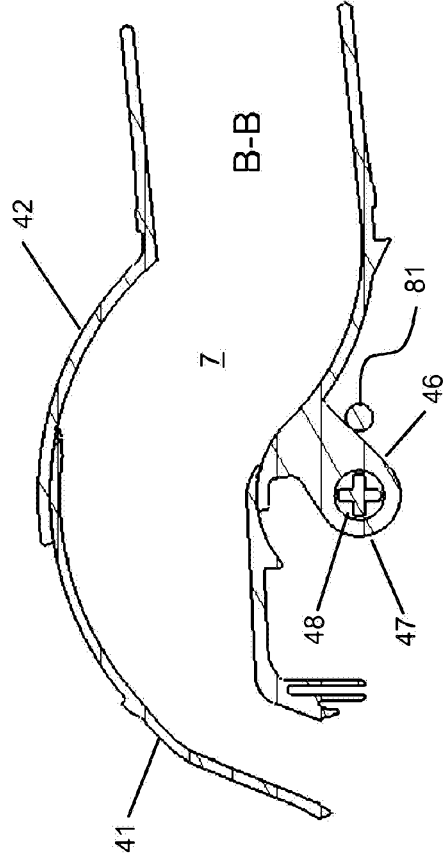

Fig. 4B

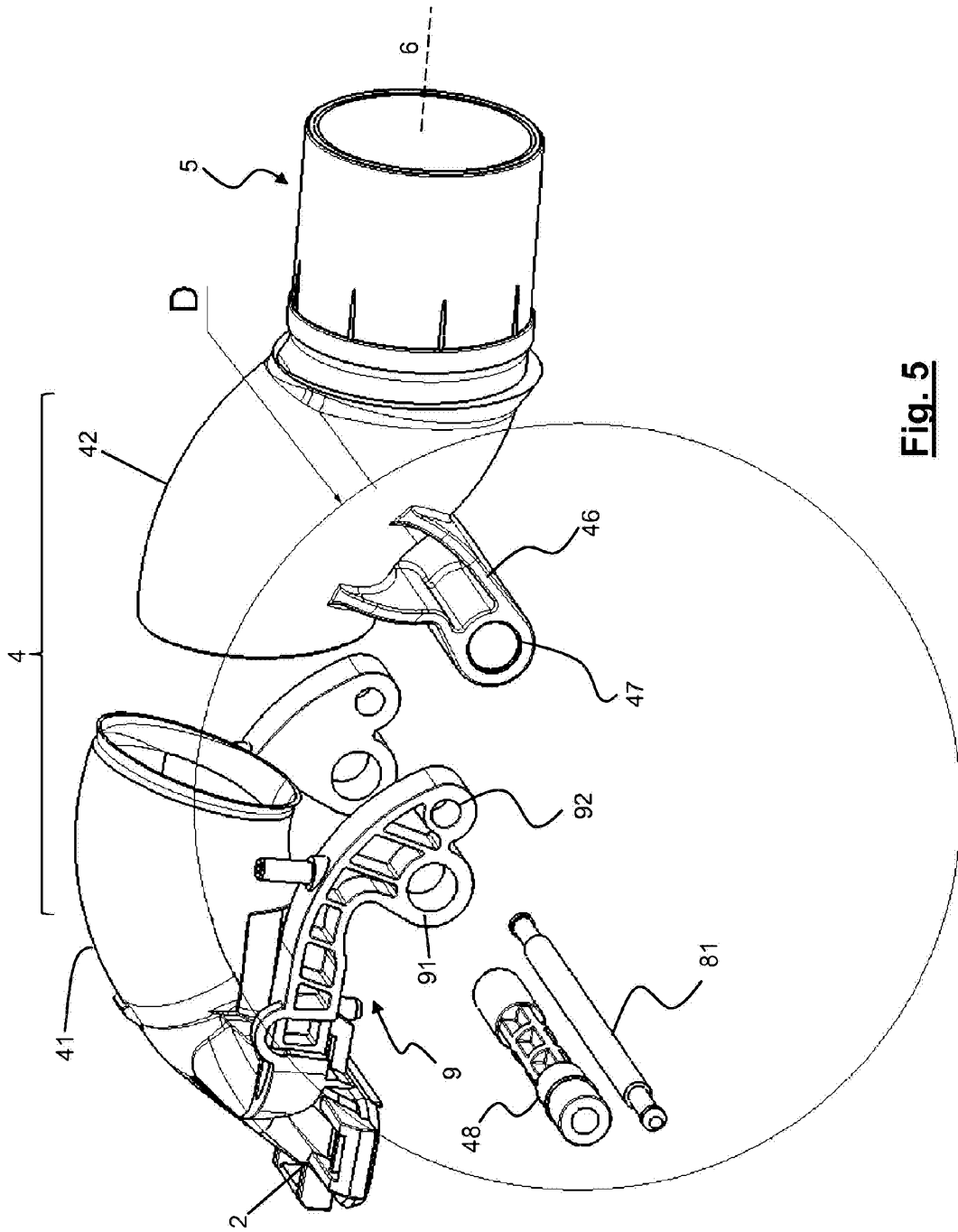

Fig. 5

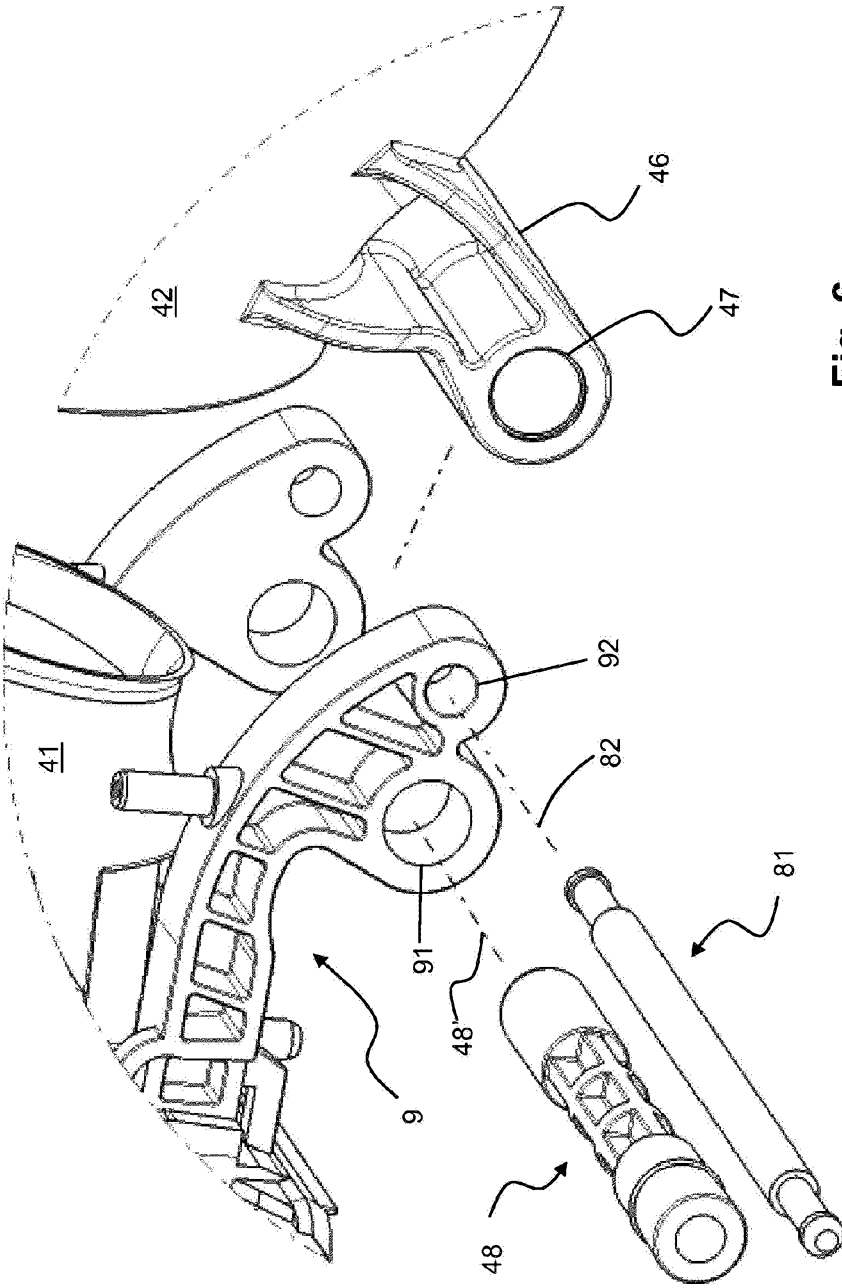

Fig. 6

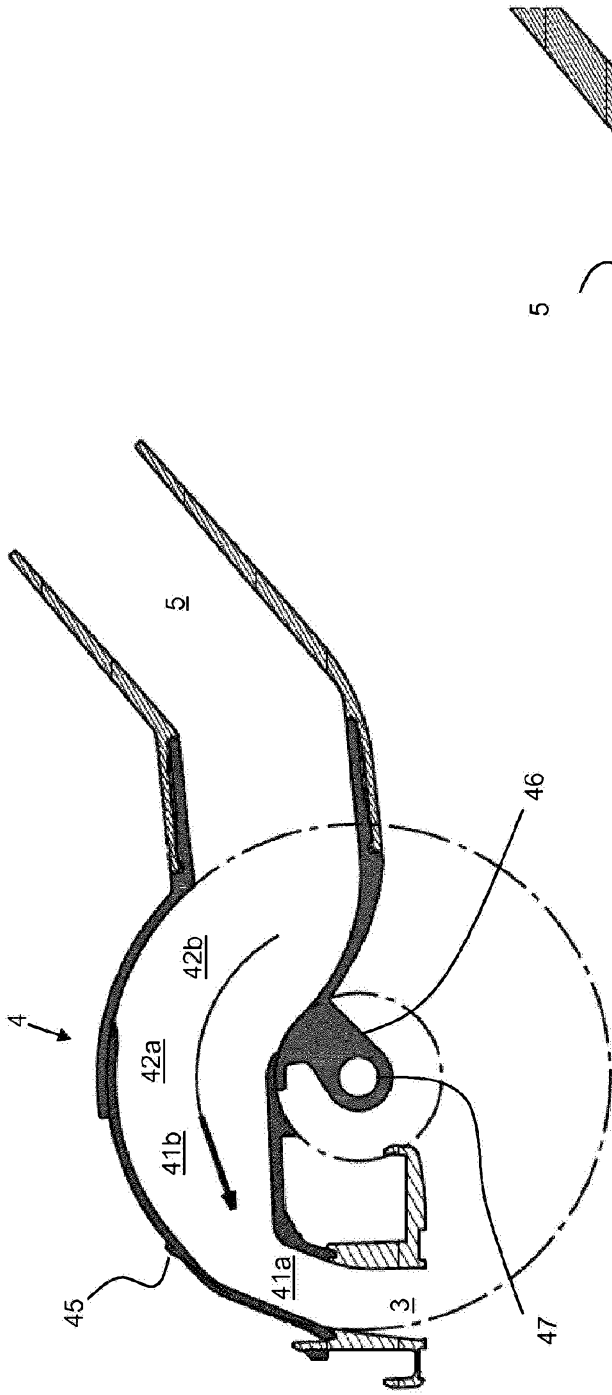

Fig. 7

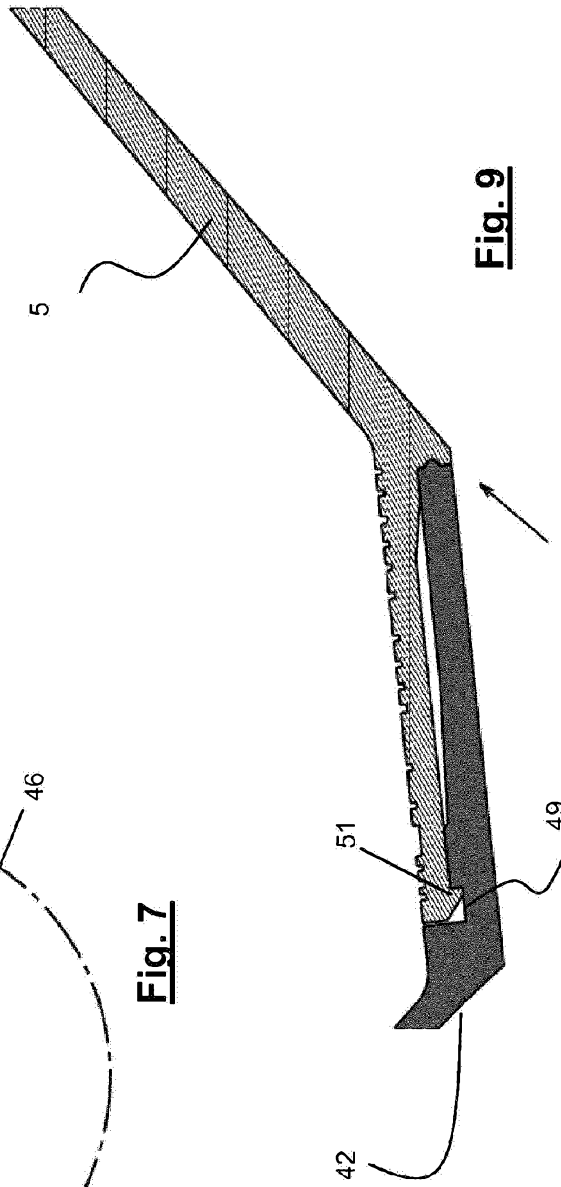

Fig. 9

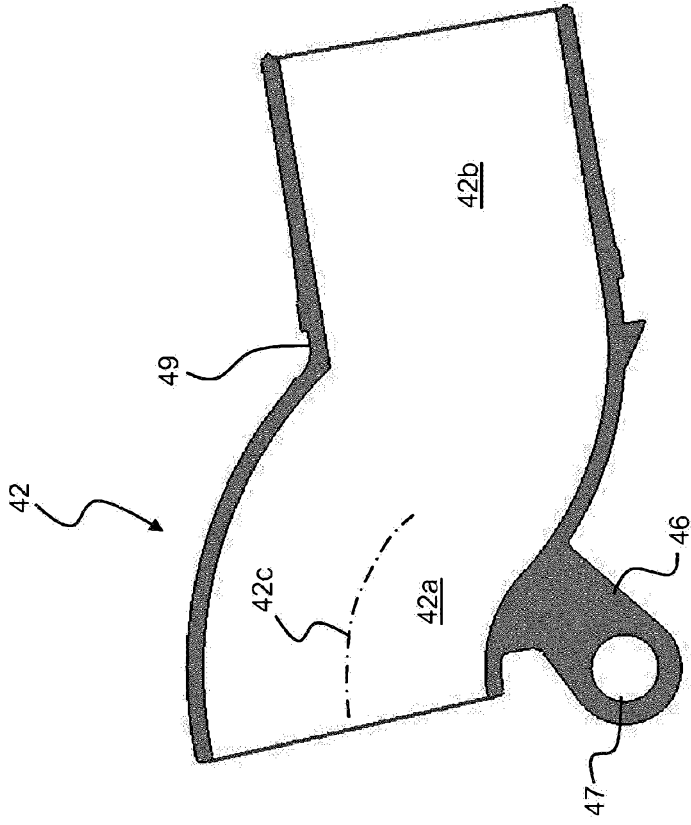

Fig. 8.1

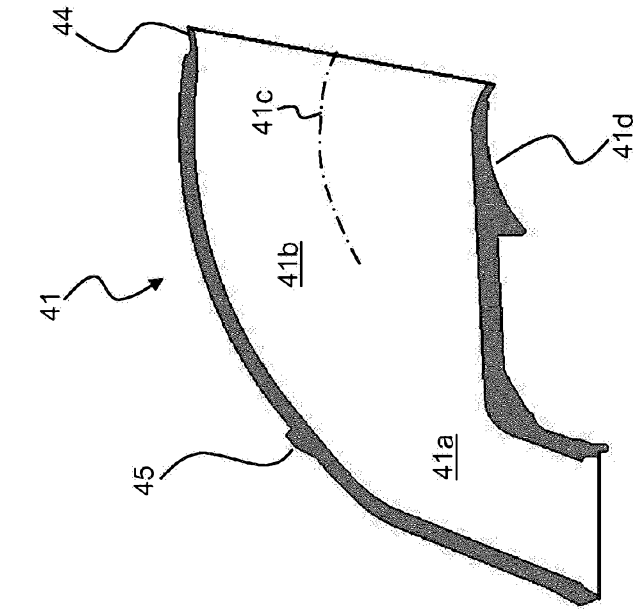

Fig. 8.2