



US 20090137865A1

(19) **United States**

(12) **Patent Application Publication**
Green, II et al.

(10) **Pub. No.: US 2009/0137865 A1**

(43) **Pub. Date: May 28, 2009**

(54) **TISSUE STABILIZER AND METHODS OF USE**

Publication Classification

(76) Inventors: **Harry Leonard Green, II**, Santa Cruz, CA (US); **Joshua K. Wallin**, Sunnyvale, CA (US)

(51) **Int. Cl.**
A61F 2/02 (2006.01)
(52) **U.S. Cl.** 600/37
(57) **ABSTRACT**

Correspondence Address:
LAW OFFICE OF ALAN W. CANNON
942 MESA OAK COURT
SUNNYVALE, CA 94086 (US)

Devices and methods are disclosed for stabilizing tissue within a patient's body during a surgical operation to provide a relatively motionless surgical field. The devices involve tissue stabilizers which provide superior engagement with a tissue structure to be stabilized, for example the beating heart. The tissue stabilizer may have one or more stabilizer feet which provide for adjustment of the orientation of the features which engage the surface of the tissue structure. In one instance, the orientation may be adjusted to ensure the engaging features will be properly aligned with the surface of the tissue structure before engagement. In addition, once engaged with or connected to the tissue structure the orientation may be adjusted to yield an optimum surgical presentation of a portion of the tissue structure, for instance a coronary artery or the like. The tissue stabilizer may be configured to use friction, negative pressure, or both to engage the surface of the heart.

(21) Appl. No.: **12/365,992**

(22) Filed: **Feb. 5, 2009**

Related U.S. Application Data

(63) Continuation of application No. 10/272,036, filed on Oct. 15, 2002, now Pat. No. 7,503,891, which is a continuation of application No. 09/366,190, filed on Aug. 3, 1999, now Pat. No. 6,511,416.

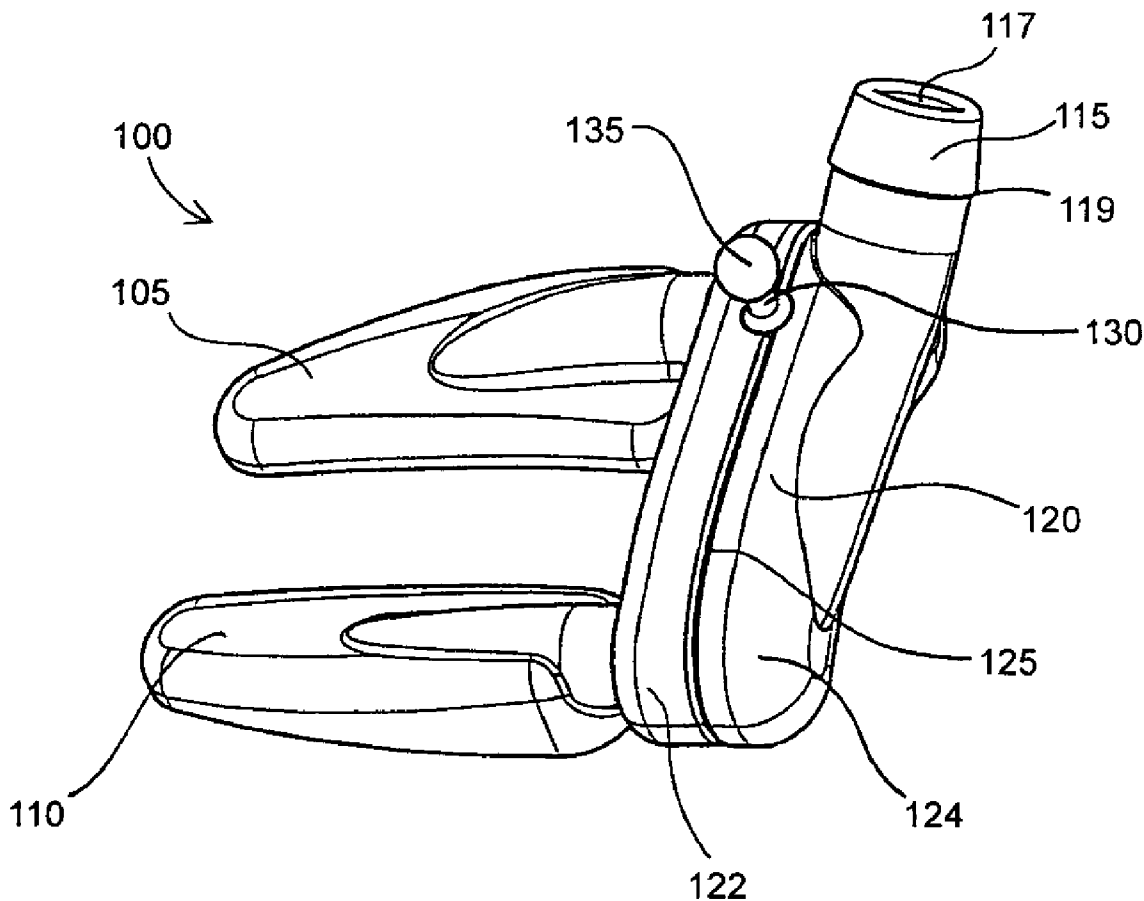

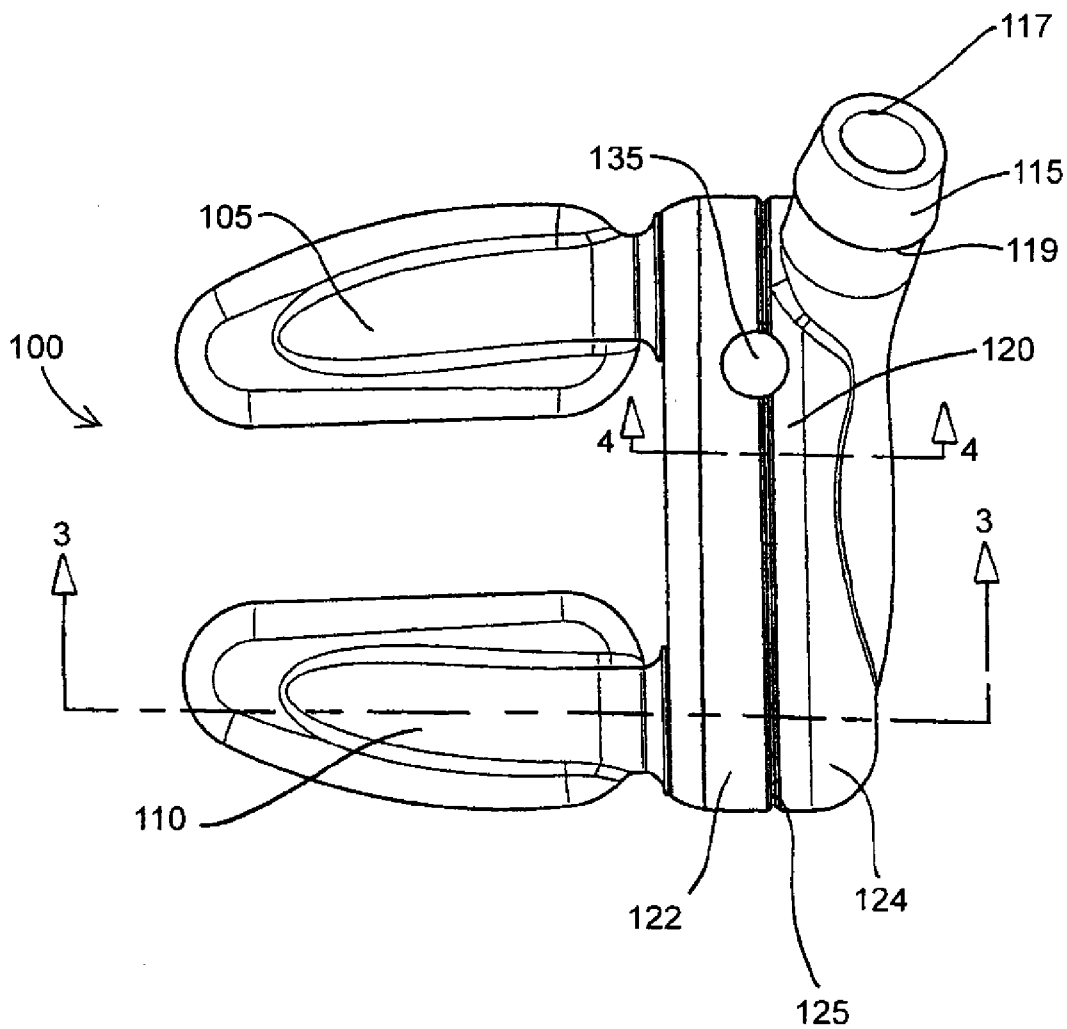
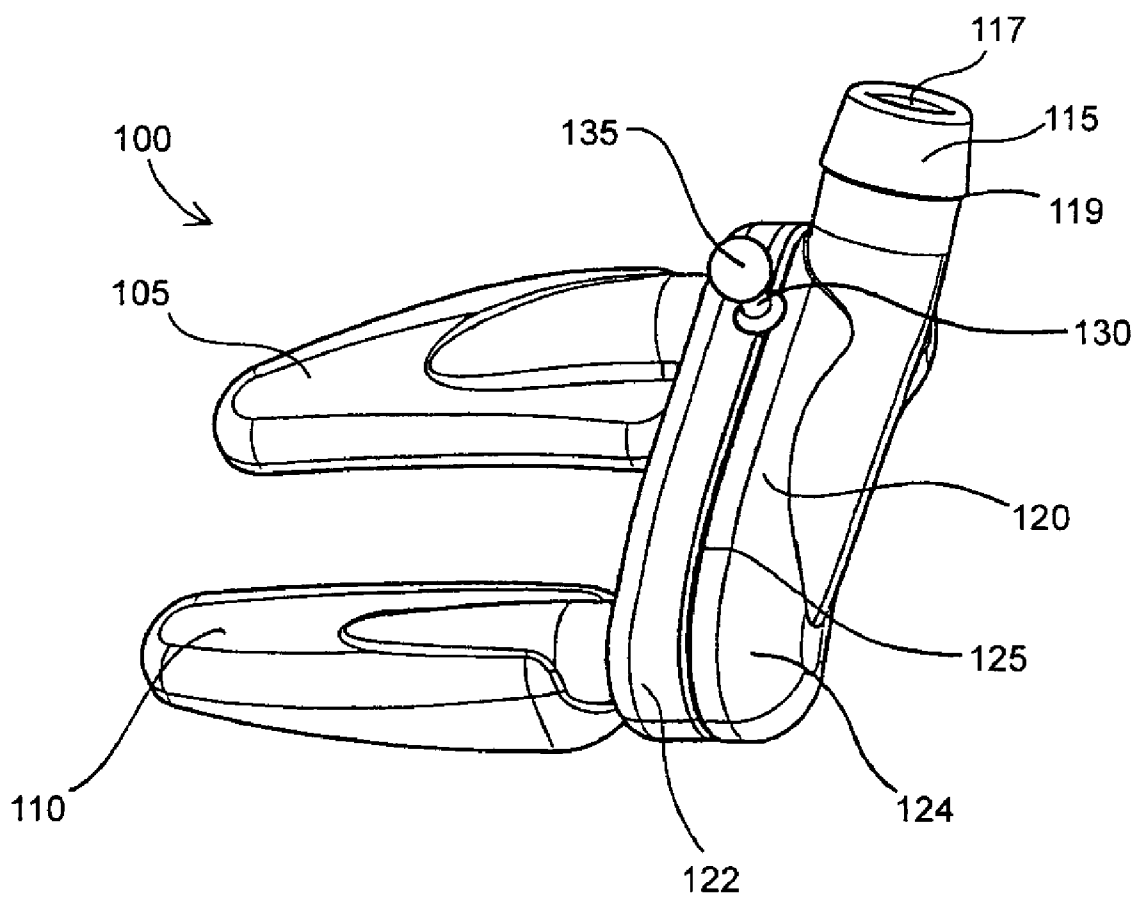

FIG. 1A

FIG. 1B



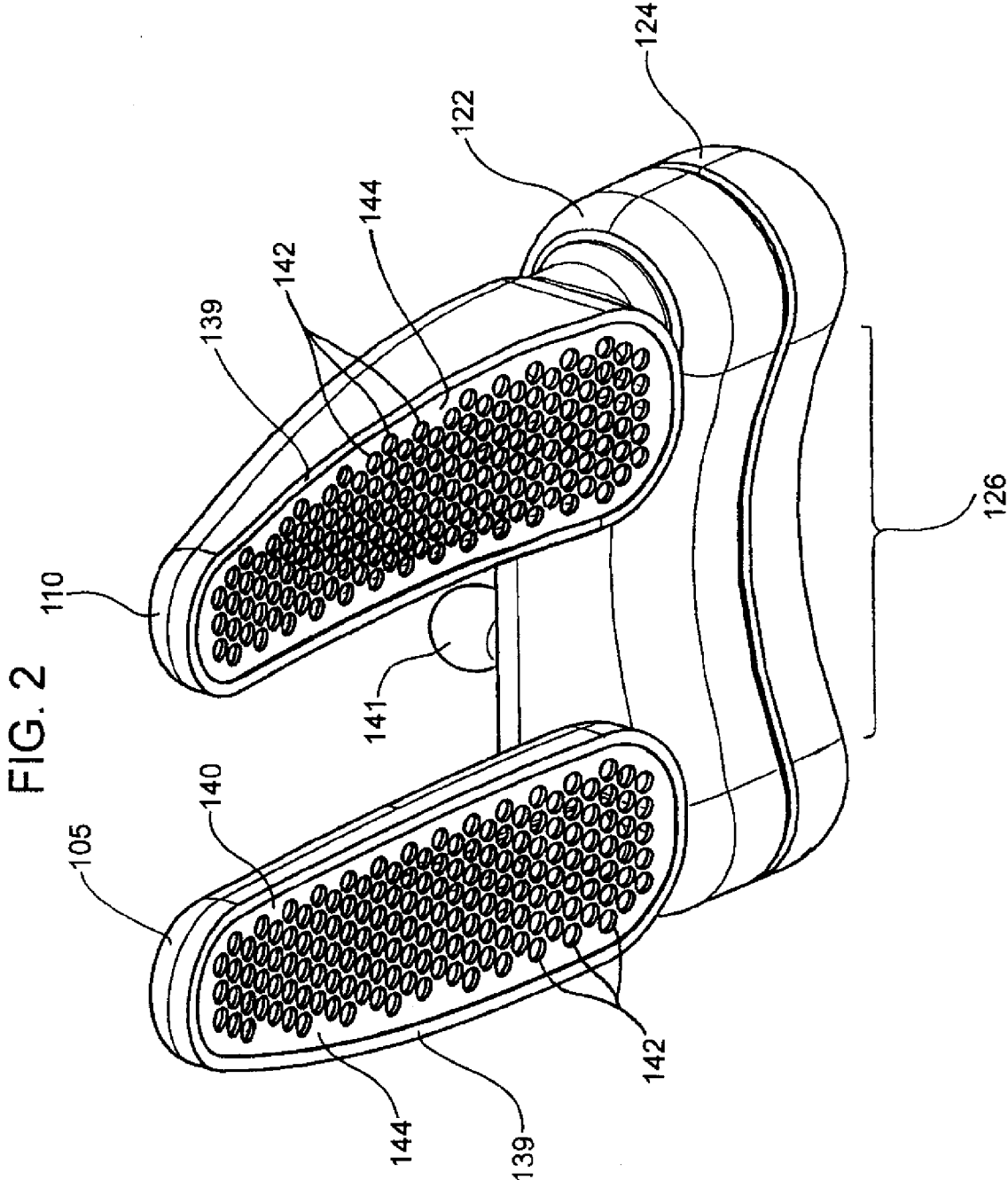

FIG. 4

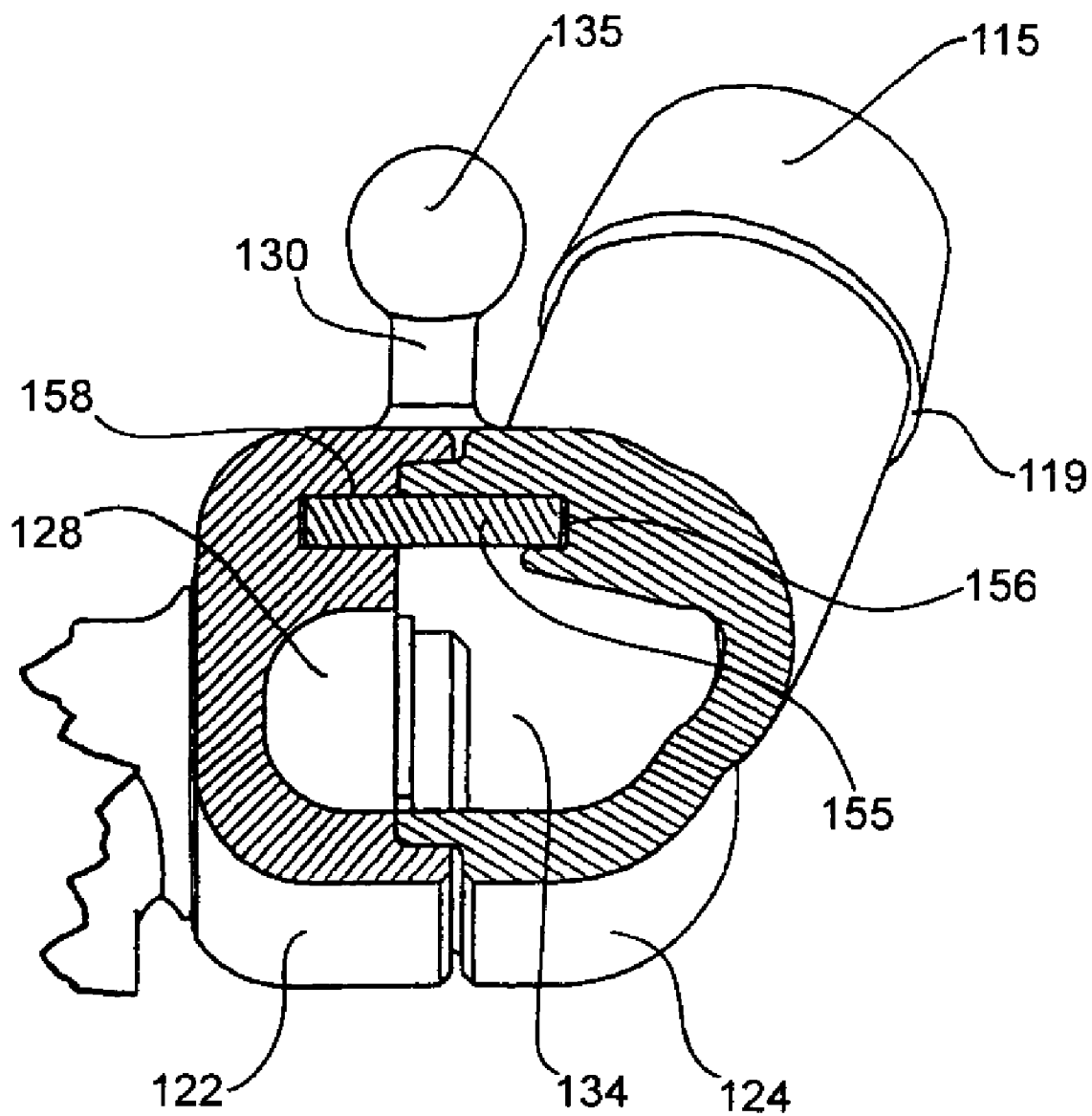

FIG. 6

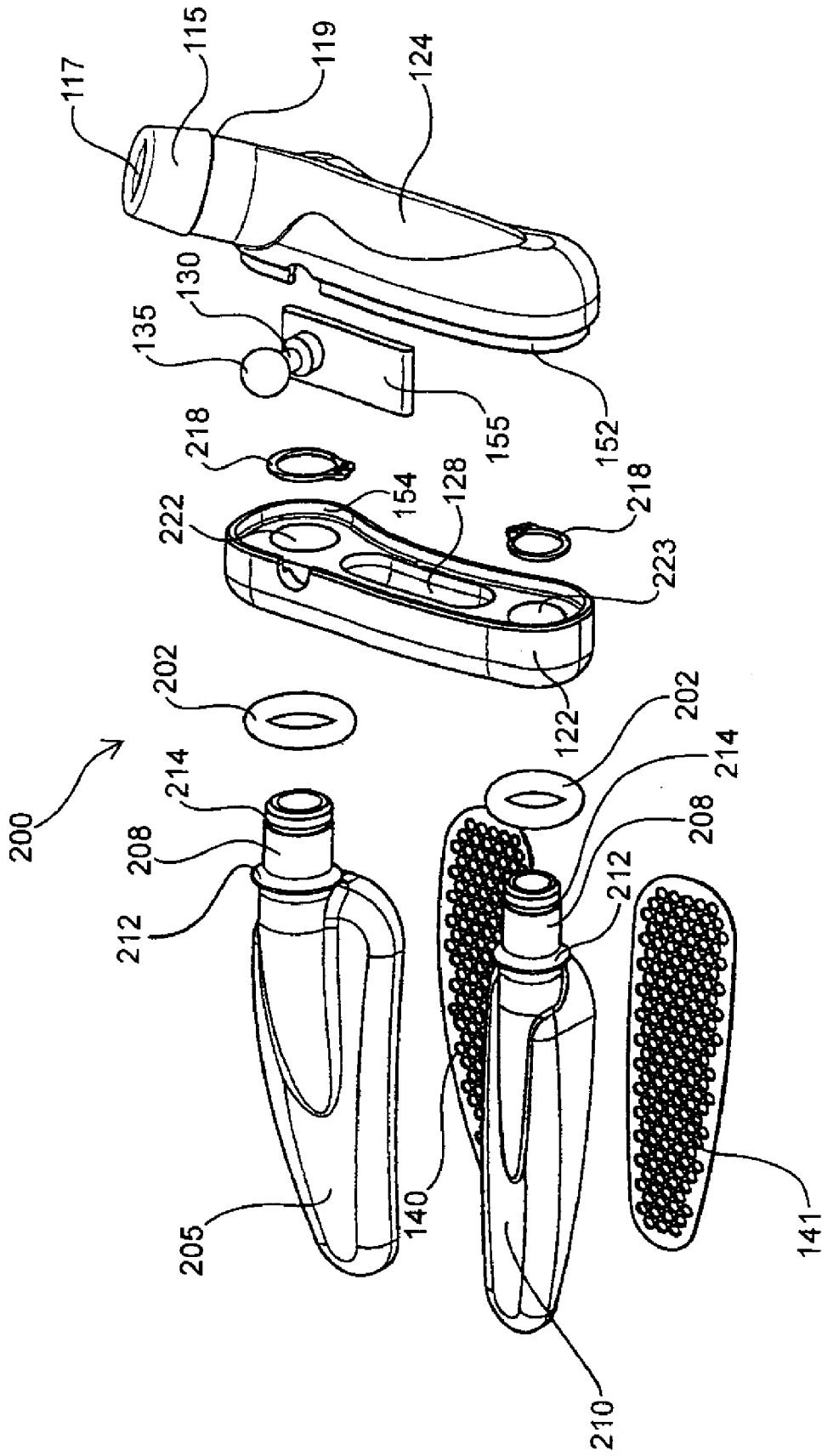
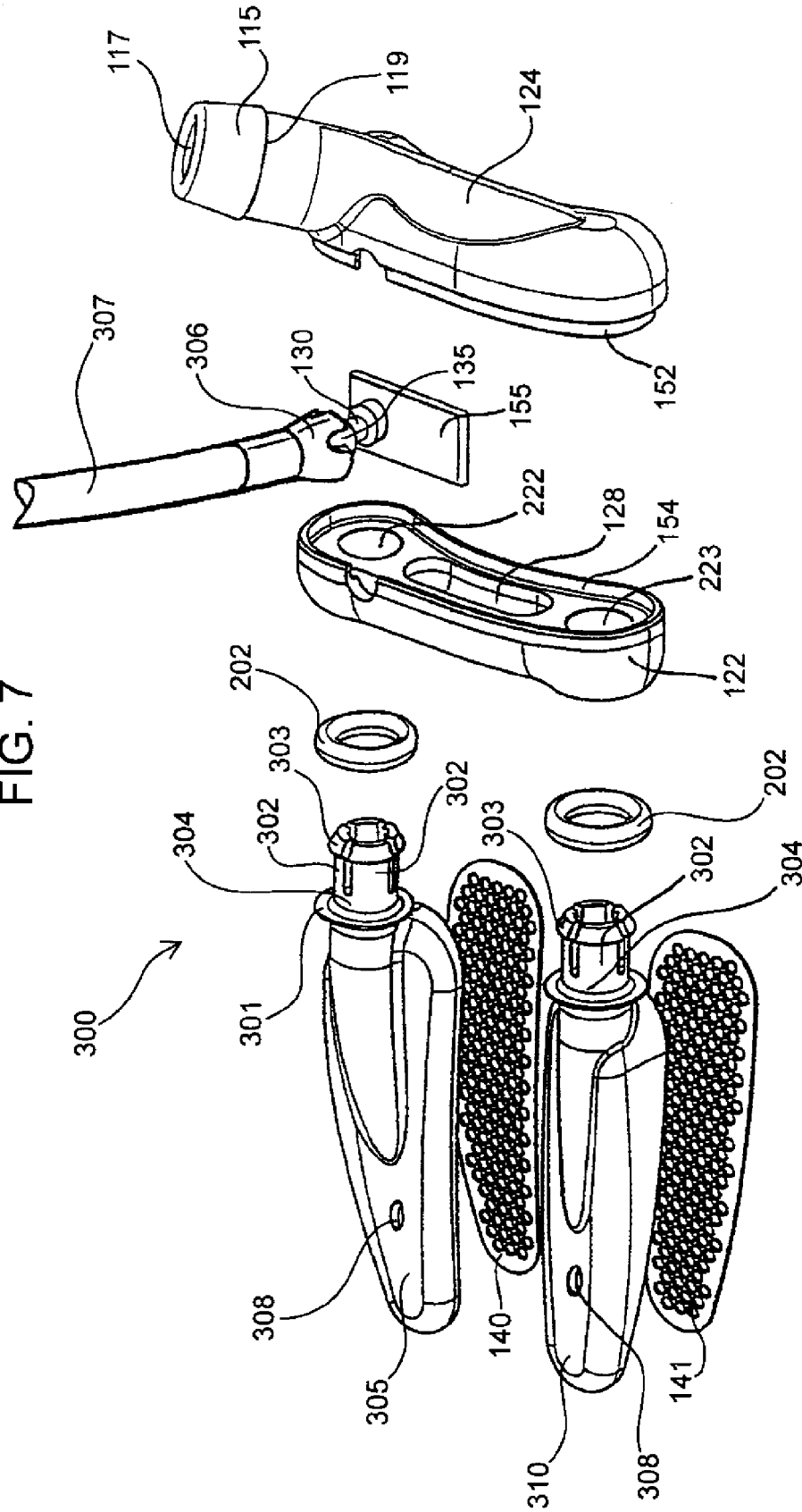

FIG. 7



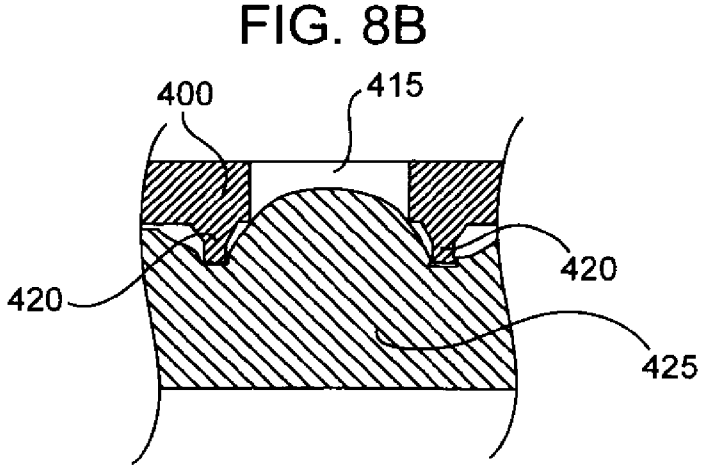
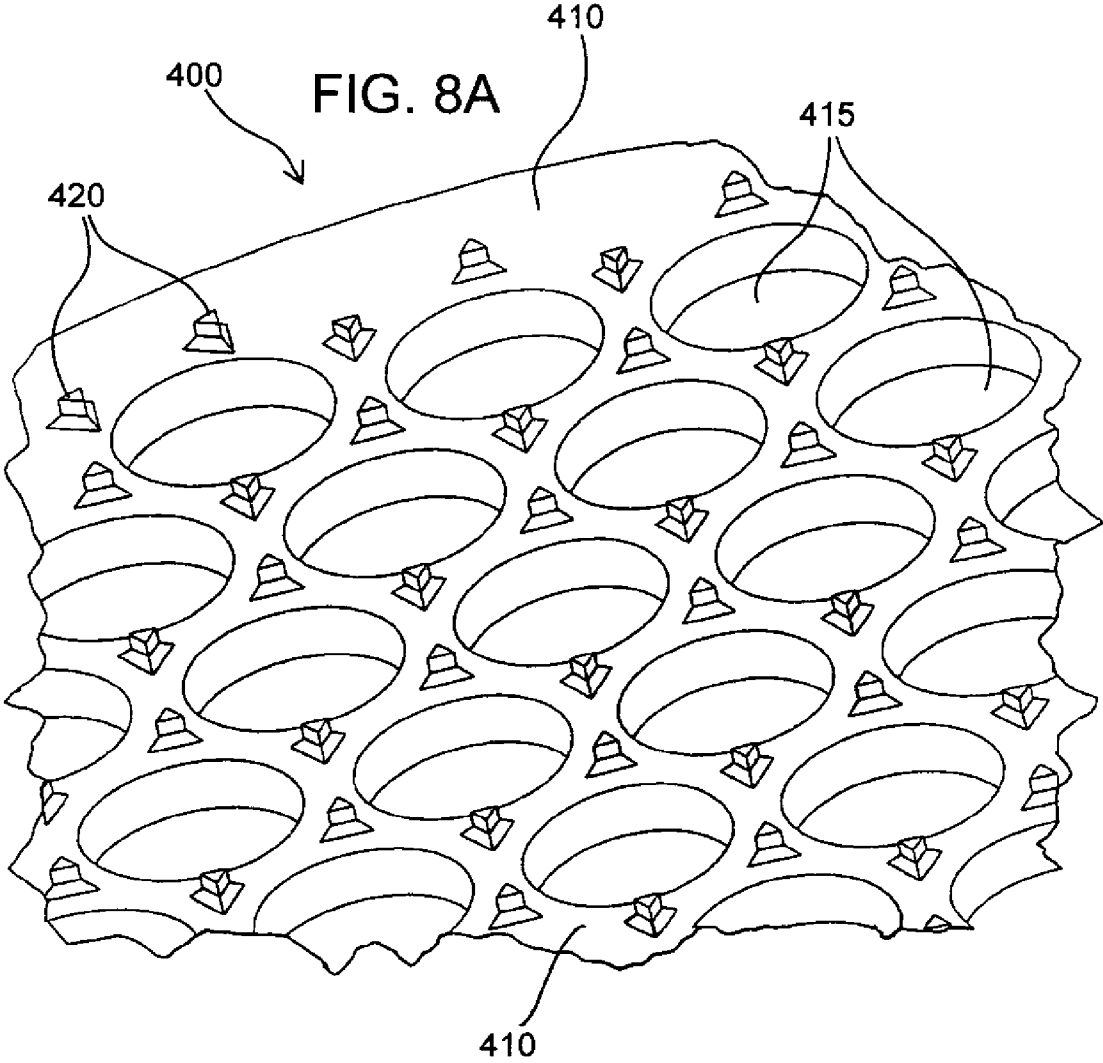

FIG. 9A

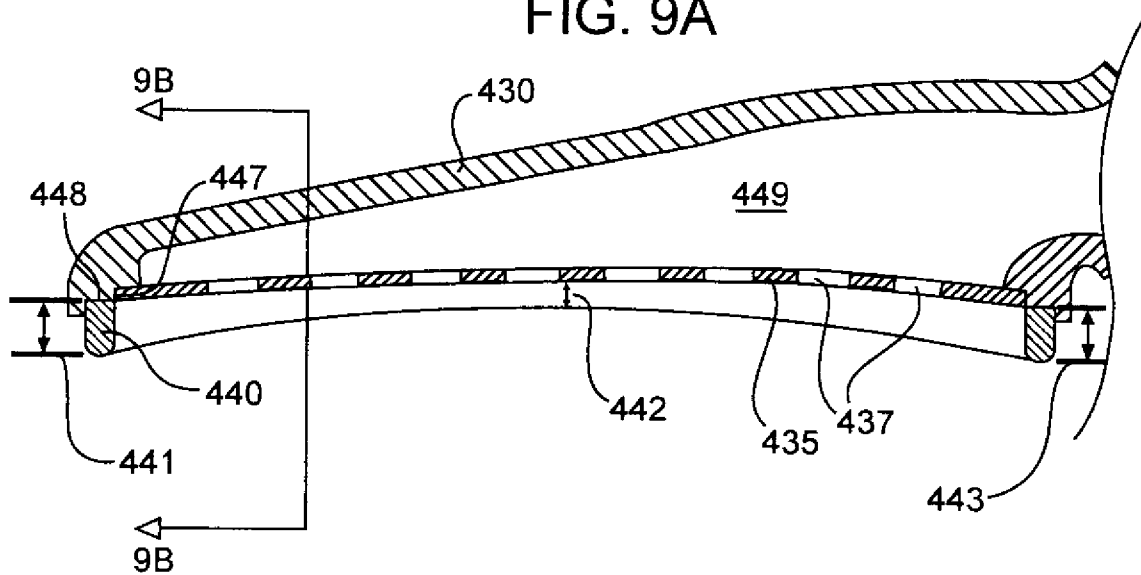

FIG. 9B

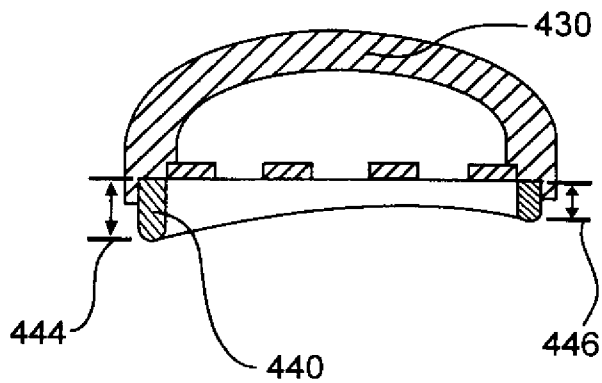

FIG. 10

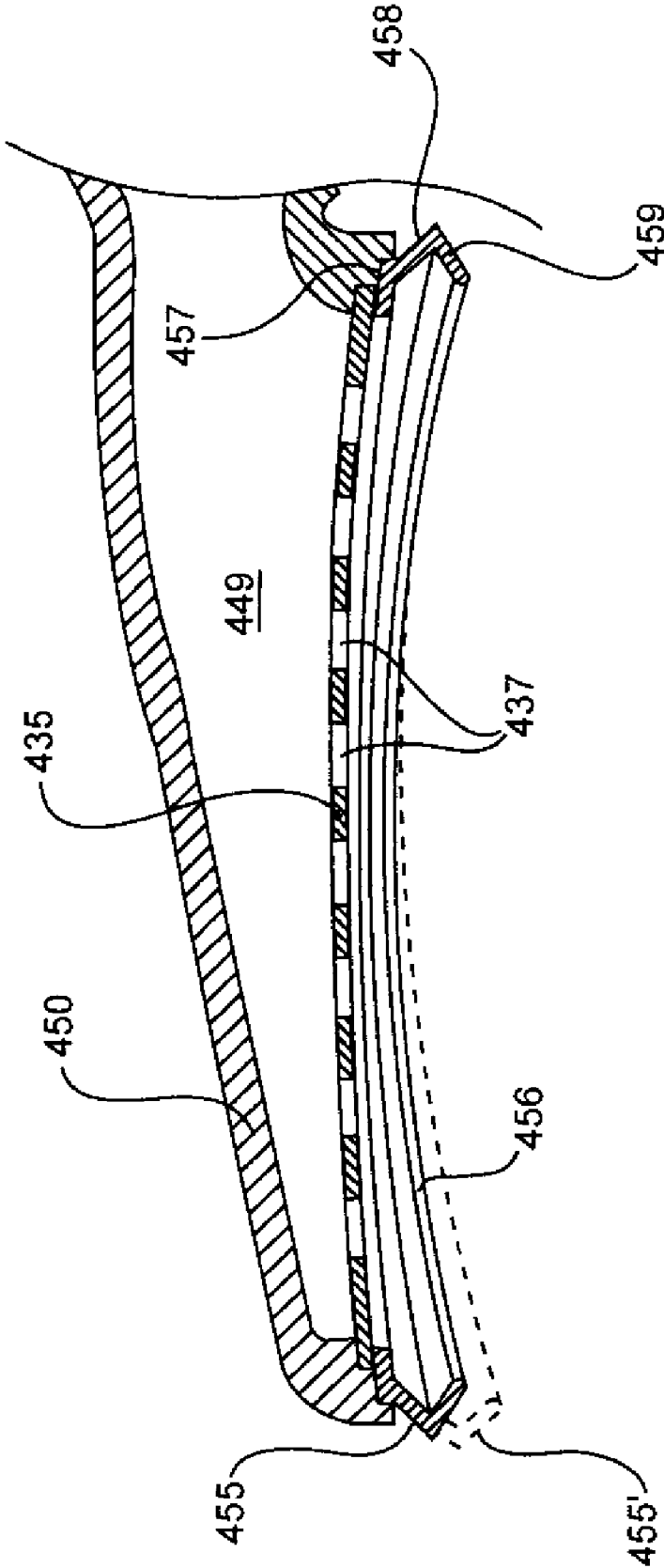

FIG. 11

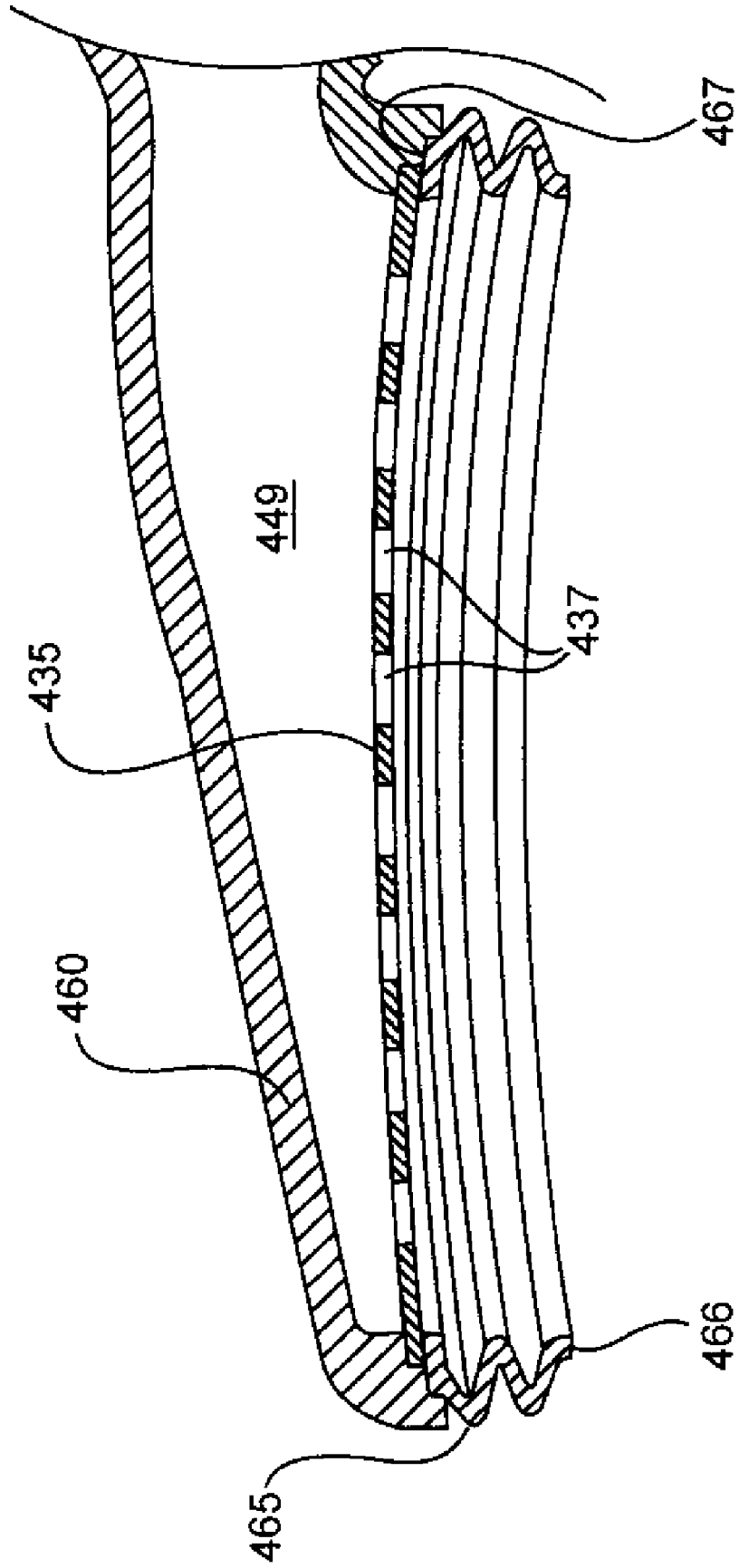
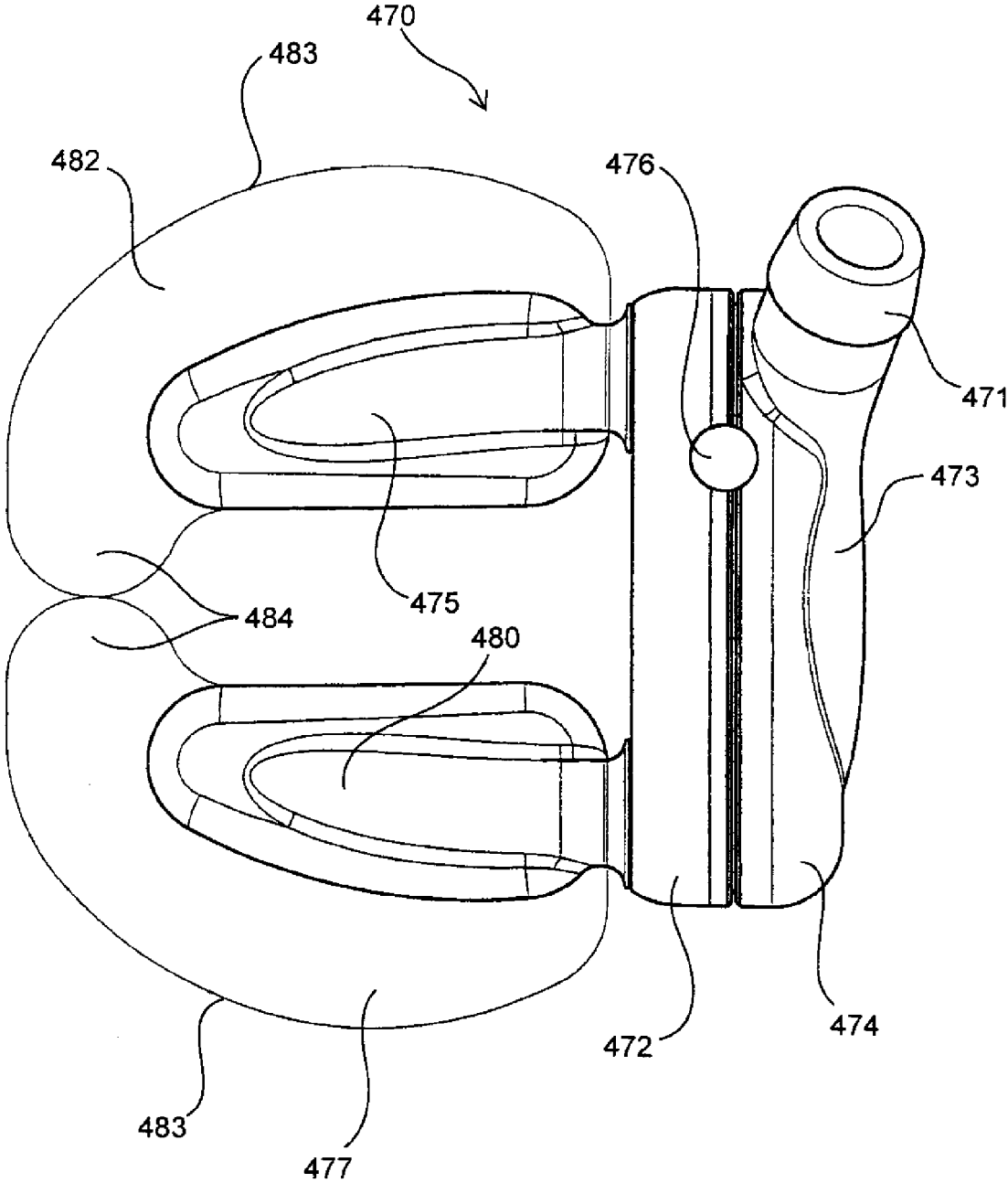

FIG. 12



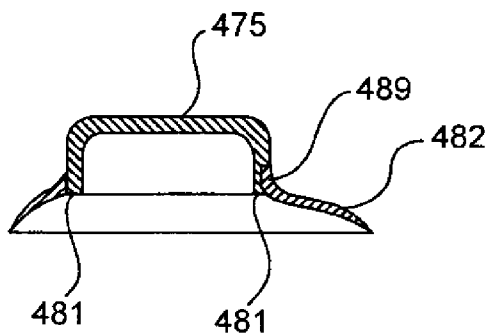
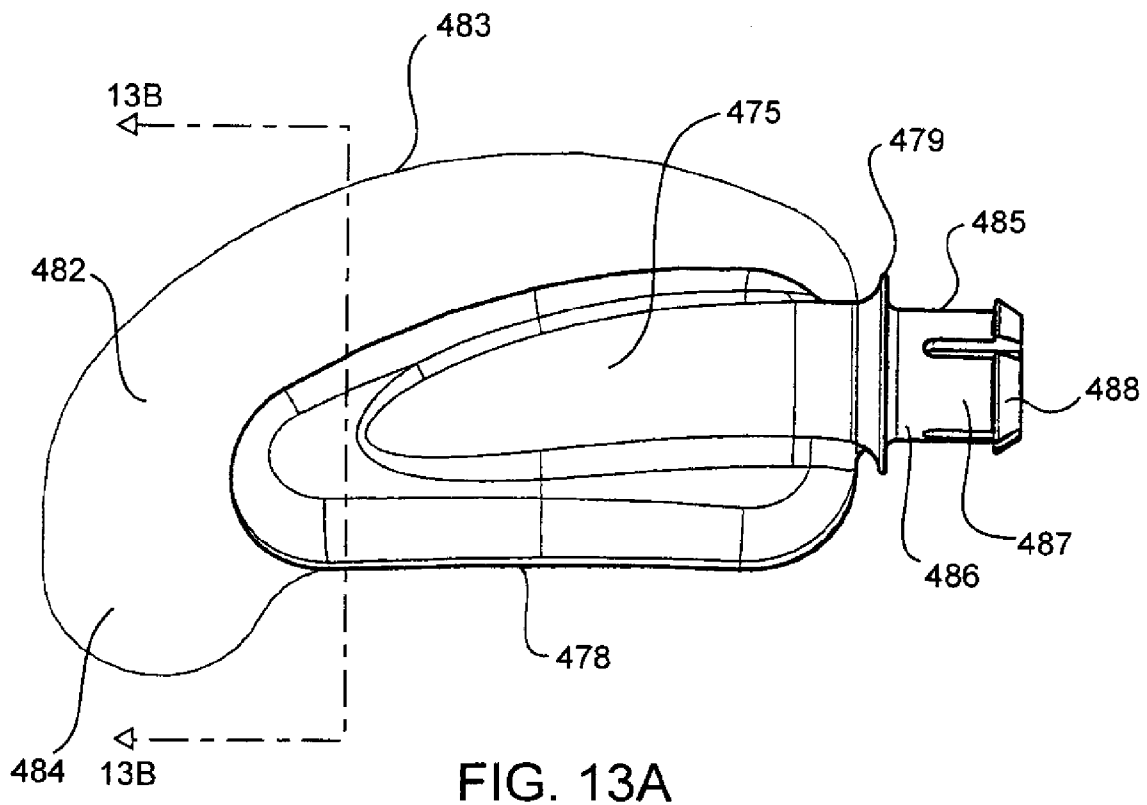

FIG. 14

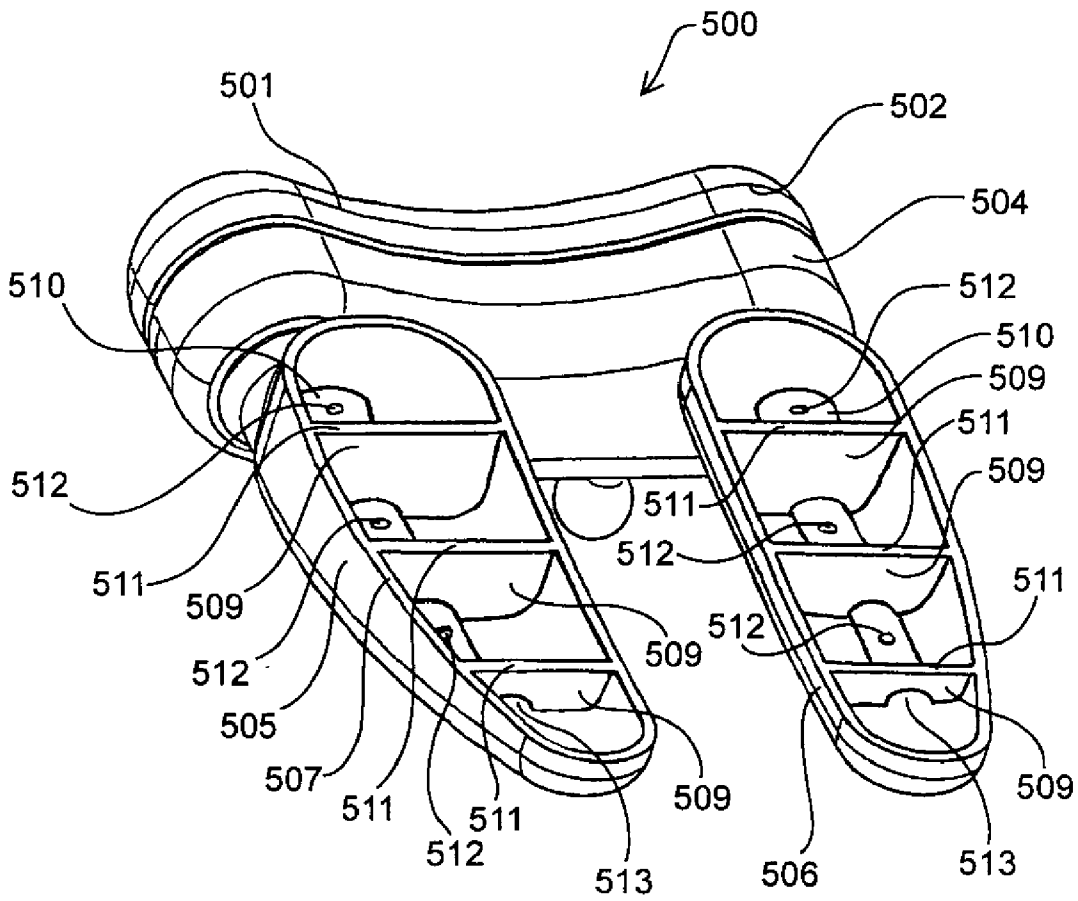
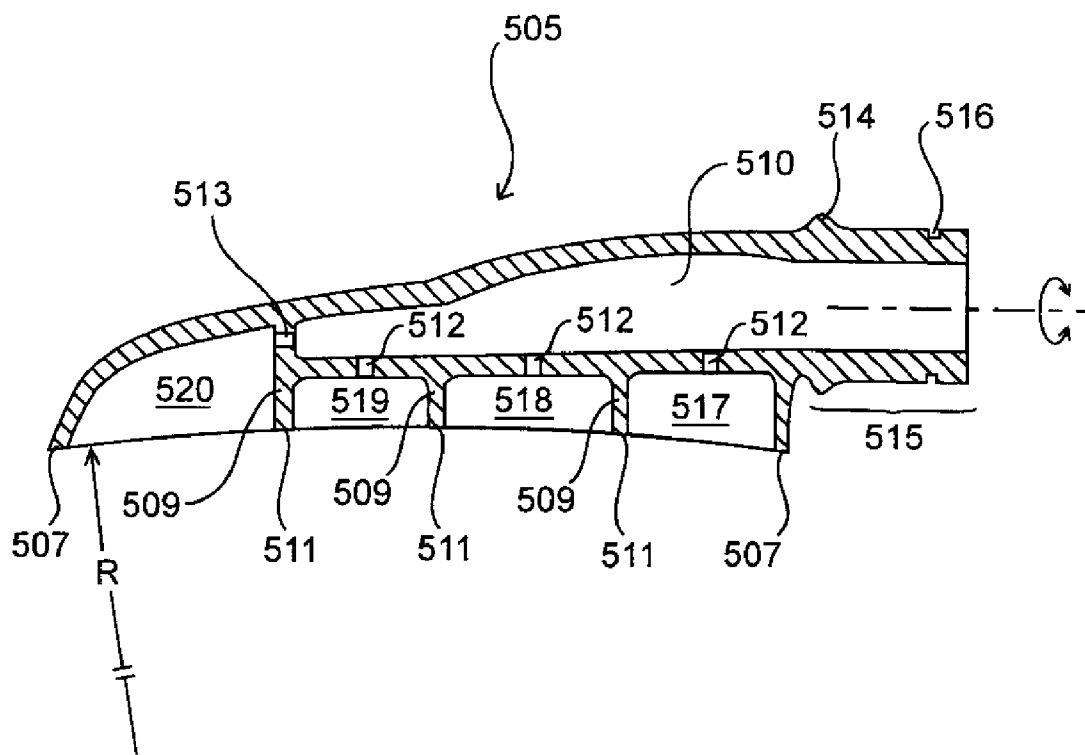
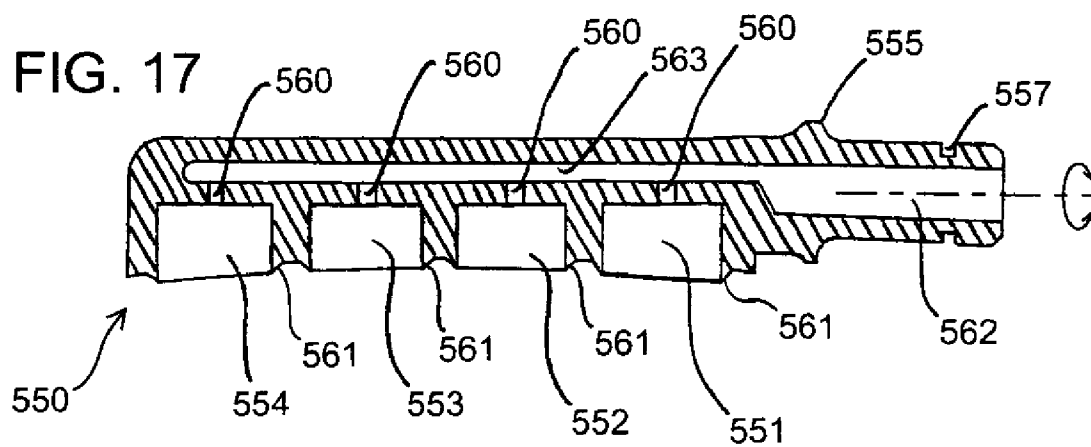
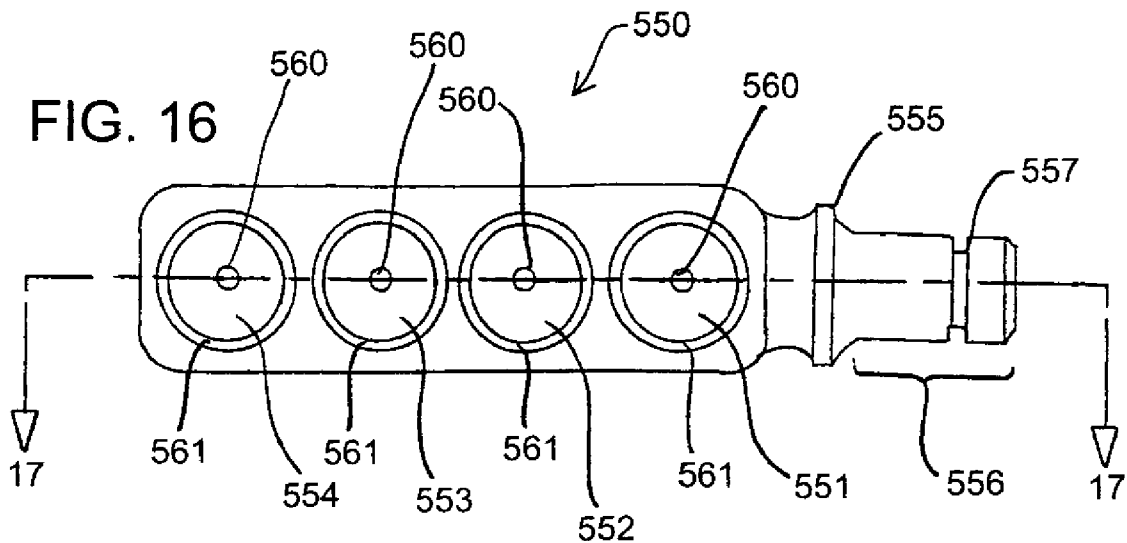

FIG. 15





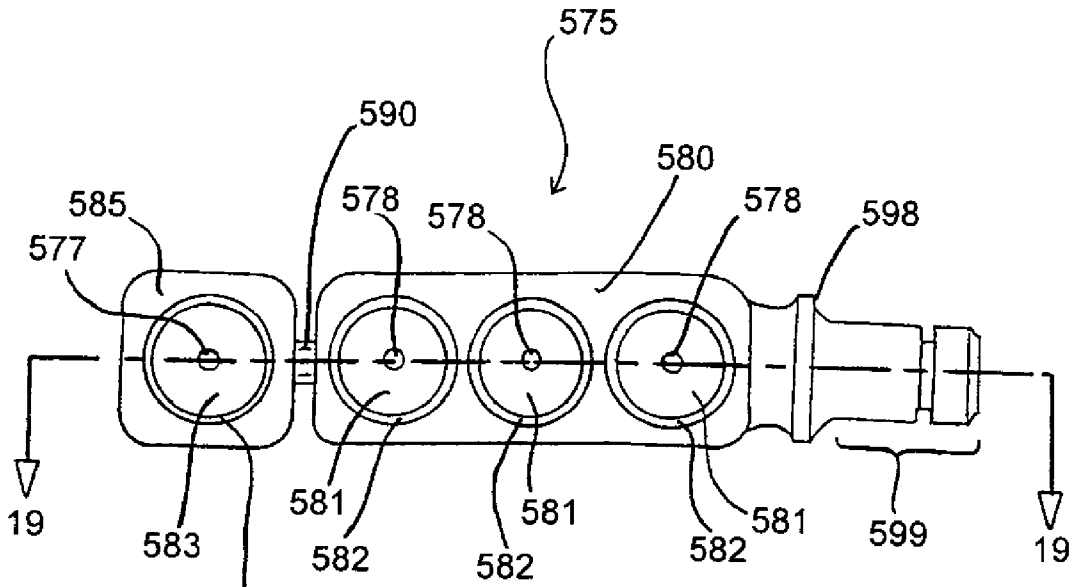

FIG. 18

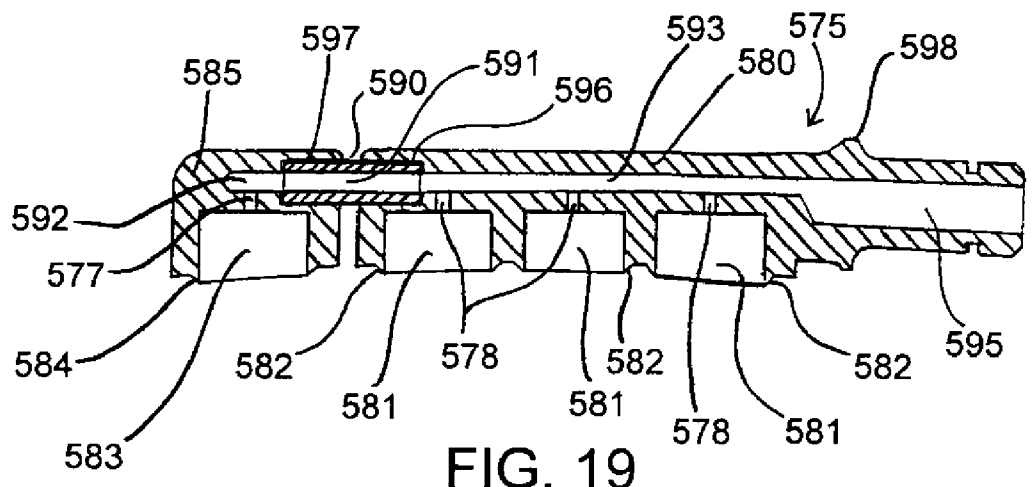

FIG. 19

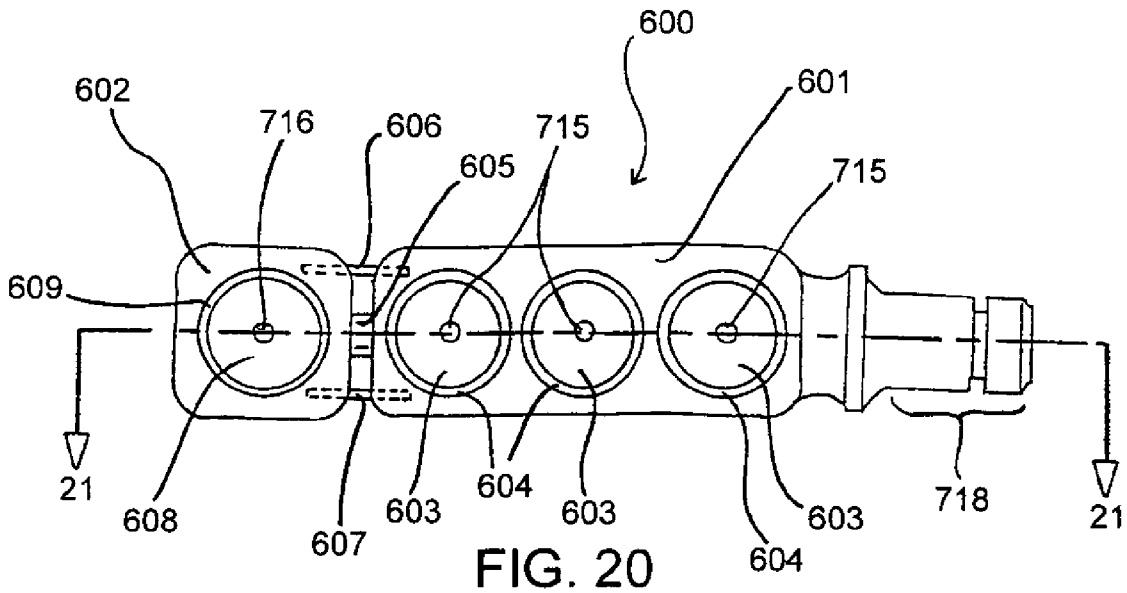

FIG. 20

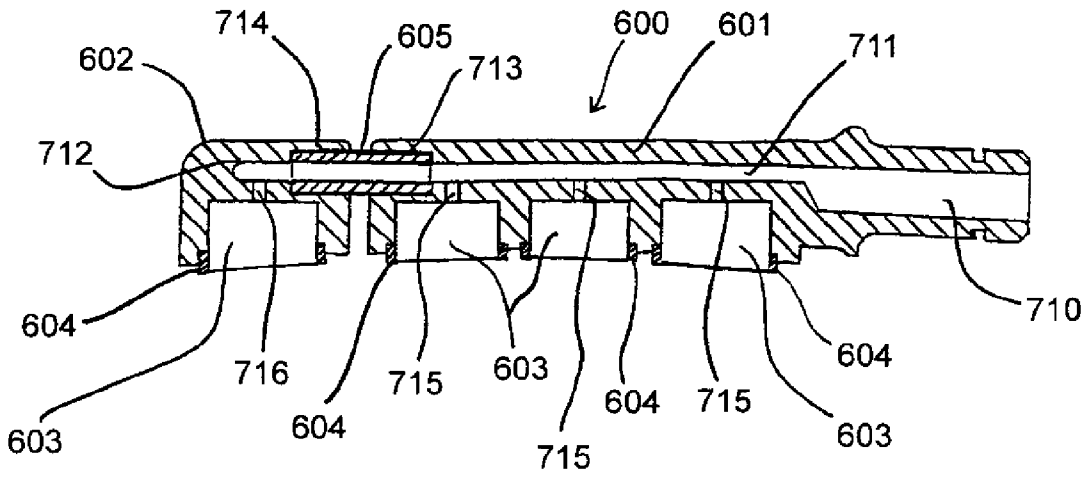
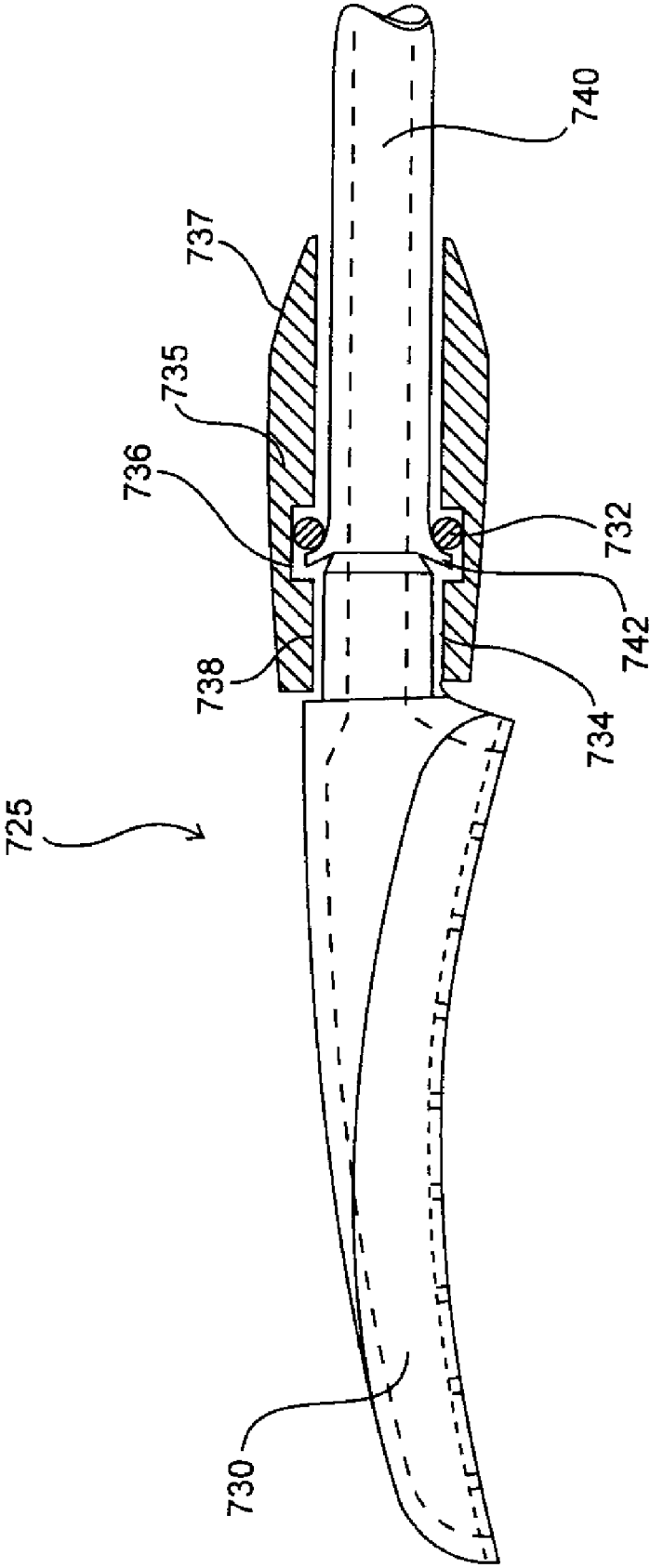

FIG. 21

FIG. 22



TISSUE STABILIZER AND METHODS OF USE

FIELD OF THE INVENTION

[0001] The present invention relates generally to surgical instruments, and more particularly to methods and apparatus for stabilizing or immobilizing tissue during surgery. The tissue stabilizers described herein are particularly useful for stabilizing the beating heart during coronary artery bypass graft surgery.

BACKGROUND OF THE INVENTION

[0002] Certain surgical procedures require the surgeon to perform delicate operations on tissues within the body that are moving or otherwise unstable. The ability to stabilize or immobilize the surgical site provides greatly improved surgical accuracy and precision and reduces the time required to complete a particular procedure. A large and growing number of surgeons, for example, are routinely performing successful coronary artery bypass graft (CABG) surgery on the beating heart by temporarily stabilizing or immobilizing a localized area of the beating heart. Methods and apparatus for performing a CABG procedure on the beating heart are described in U.S. Pat. No. 5,894,843 and U.S. Pat. No. 5,727,569 to Benetti et al., the entirety of which is herein incorporated by reference.

[0003] In a typical CABG procedure, a blocked or restricted section of coronary artery, which normally supplies blood to some portion of the heart, is bypassed using a source vessel or a graft vessel to re-establish blood flow to the artery downstream of the blockage. This procedure requires the surgeon to create a fluid connection, or anastomosis, between the source or graft vessel and an arteriotomy or incision in the coronary artery. Forming an anastomosis between two vessels in this manner is a particularly delicate procedure requiring the precise placement of tiny sutures in the tissue surrounding the arteriotomy in the coronary artery and the source or graft vessel.

[0004] The rigors of creating a surgical anastomosis between a coronary artery and a graft or source vessel demands that the target site for the anastomosis be substantially motionless. To this end, a number of devices have been developed which are directed to stabilizing a target site on the beating heart for the purpose of completing a cardiac surgical procedure, such as completing an anastomosis. Representative devices useful for stabilizing a beating heart are described, for example, in U.S. Pat. Nos. 5,894,843; 5,727,569; 5,836,311; and 5,865,730.

[0005] As beating heart procedures have evolved, new challenges have arisen in the design and engineering of the stabilization devices. The heart is typically accessed by way of a surgical incision such as a sternotomy or thoracotomy. Often one or more of the blocked or restricted coronary arteries are located a good distance away from the access incision requiring the stabilization device to traverse a longer and more tortuous path and engage the surface of the heart at somewhat difficult angular relationships or orientations. Under the most severe conditions, devices which operate to provide a mechanical compression force to stabilize the beating heart encounter difficulty maintaining mechanical traction against the surface of the heart. Similarly, devices which

utilize vacuum to engage the heart have a great deal of difficulty creating and maintaining an effective seal against the moving surface of the heart.

[0006] Even when the beating heart has been effectively stabilized, the target coronary artery may be obscured by layers of fat or other tissue and is very difficult for the surgeon to see. Moreover, the stabilization devices may distort the tissue surrounding the coronary artery or the coronary artery itself such that the arteriotomy is maintained in an unfavorable presentation for completion of the anastomosis. For example, the coronary artery in the area of the arteriotomy may become excessively flattened, compressed or stretched in a manner that impedes the placement of sutures around the perimeter of the arteriotomy.

[0007] In view of the foregoing, it would be desirable to have methods and devices for stabilizing the beating heart that are capable of maintaining atraumatic engagement with the surface of the beating heart over a wider range of conditions and orientations. It would be further desirable to have stabilization methods and devices which provide for favorable presentation of the coronary artery.

SUMMARY OF THE INVENTION

[0008] The present invention will be primarily described for use in stabilizing the beating heart during a surgical procedure, but the invention is not limited thereto, and may be used in other surgical procedures.

[0009] The present invention is a tissue stabilizer having one or more stabilizer feet that may be adjusted or oriented to provide optimal engagement against the tissue to be stabilized or to provide an optimal presentation of a portion of the stabilized tissue. The present invention may also include a tissue stabilizer having one or more flexible or compressible seals to ensure a reliable seal against the target tissue and may also include a stabilizer foot having at least one portion which is adjustable relative to the remainder of the stabilizer foot.

[0010] One aspect of the present invention involves a device for stabilizing tissue within a patient's body comprising a base member, a first stabilizer foot extending outwardly from the base member and being rotatable relative to the base member about a first axis, and a second stabilizer foot extending outwardly from the base member and being rotatable relative to the base member about a second axis. Preferably, the first and second stabilizer feet are independently rotatable relative to the base member. In a preferred embodiment, the first axis and the second axis are substantially parallel.

[0011] The first and second stabilizer feet may each have hollow interiors defining first and second vacuum chambers each having at least one opening adapted to engage at least a portion of the tissue. The openings adapted to engage at least a portion of the tissue to be stabilized may have a raised seal around a perimeter thereof. In one variation the raised seal is made of a substantially rigid material. In other variations the raised seal is made of an elastomeric material or a compressible foam material.

[0012] The base member may comprise an interior chamber therein, the interior chamber of the base member being in fluid communication with the first and second vacuum chambers. The base member may comprise a front base portion and a rear base portion, the front base portion being sealingly affixed to the rear base portion. The device may also include a post having a distal end connected to the base member and a proximal end terminating in a ball-shaped member. A shaft

may be provided having a socket at a distal end, the socket being operably engaged with the ball.

[0013] Another aspect of the present invention involves a device for stabilizing tissue within a patient's body having a base member and at least one stabilizer foot extending outwardly from the base member in a first direction, the stabilizer foot being rotatable relative to the base member about an axis of rotation which is oriented in substantially the same direction as the first direction. Preferably, the axis of rotation is at an angle of no more than about 25° to the first direction, more preferably, the axis of rotation is substantially parallel to the first direction.

[0014] In a preferred variation, the stabilizer foot has tissue engaging features adapted to engage an external surface of the tissue to be stabilized, the tissue engaging features being disposed at the bottom of the stabilizer foot. The tissue engaging features may comprise a vacuum chamber, preferably having a single opening for engaging the tissue to be stabilized, or may comprise a plurality of vacuum ports. The tissue engaging features may also comprise a textured surface, a perforated sheet, or a perforated sheet having projections extending outwardly therefrom. Preferably, the axis of rotation of the stabilizer foot is offset from the tissue engaging features, more preferably offset from and parallel to the tissue engaging features.

[0015] The stabilizer foot may have a hollow interior defining a vacuum chamber with a bottom opening adapted to engage at least a portion of the tissue. The stabilizer foot may also have a raised seal disposed around a perimeter of said opening, preferably around substantially the entire perimeter. The raised seal may be made from a rigid material, an elastomer, or a compressible foam. The vacuum chamber may have an inlet passage in fluid communication with a source of negative pressure. Preferably, the inlet passage is in fluid communication with an interior chamber within the base member. The base member may include an external fluid connection to supply negative pressure to the interior chamber of the base member.

[0016] Another aspect of the present invention involves a device for stabilizing a coronary artery on a patient's heart comprising a base member and a stabilizer foot for engaging a portion of the patient's heart. The base member has an interior chamber and at least a first bore, typically a cylindrical bore, having a first end in fluid communication with the interior chamber of the base member and a second end open to the exterior of the base member. The stabilizer foot has a substantially cylindrical fitting having a longitudinal axis, at least a portion of the fitting positioned within the bore and being rotatable within the bore about the longitudinal axis.

[0017] The stabilizer foot may have a hollow interior defining a vacuum chamber, the vacuum chamber having at least one chamber opening adapted to engage at least a portion of the heart. The fitting may further have a fluid passage having a first end in fluid communication with the interior chamber of the base member and a second end in fluid communication with the vacuum chamber of the stabilizer foot. A raised seal may be disposed substantially completely around the perimeter of the chamber opening. The raised seal may be rigid, compressible or flexible, preferably compressible or flexible. In a preferred embodiment, the raised seal has a durometer with a valve in the range of between about 35 Shore-A to about 100 Shore-A.

[0018] The stabilizer foot fitting may comprise a flange and further include an annular seal positioned adjacent the flange.

Preferably, the annular seal is positioned between the flange and the base member. The annular seal is preferably an O-ring. The fitting includes at least one flexure having a free end and a raised portion extending radially from the free end. The raised portion preferably engages the first end of the first cylindrical bore to restrict movement of the fitting relative to the base member.

[0019] The tissue stabilizer may further include a second substantially cylindrical bore having a first end in fluid communication with the interior chamber of the base member and a second end open to the exterior of the base member. The tissue stabilizer may have a second stabilizer foot having a substantially cylindrical fitting having a longitudinal axis, at least a portion of the second stabilizer fitting positioned within the second bore and being rotatable within the second bore about the longitudinal axis of the fitting of the second stabilizer foot.

[0020] Another aspect of the present invention involves a stabilizer foot for use in engaging a portion of tissue within a patient's body which includes a first foot portion having at least one vacuum port, a second foot portion having at least one vacuum port, and at least one malleable member connecting the first foot portion to the second foot portion, whereby the orientation of the first foot portion can be adjusted relative to the second foot portion. Preferably, the first foot portion is a substantially rigid unitary member having at least two vacuum ports.

[0021] The first foot portion may have a fluid passage in fluid communication with each of the vacuum ports associated with the first foot portion and the second foot portion may have a fluid passage in fluid communication with each of the vacuum ports associated with the second foot portion. The malleable member may be a cylindrical tube having a first end, a second end, and a lumen extending therebetween, the lumen fluidly connecting the fluid passage of the first foot portion with the fluid passage of the second foot portion, preferably, the tube is made of stainless steel. In another variation, a flexible tube may be provided to connect the fluid passage of the first foot portion to the fluid passage of the second foot portion. The malleable member is then preferably offset from the flexible tube. Preferably, the stabilizer foot includes two malleable members offset from opposing sides of the flexible tube.

BRIEF DESCRIPTION OF THE DRAWINGS

[0022] FIGS. 1A and 1B are top plan and top perspective views, respectively, of a tissue stabilizer constructed according to the principles of the present invention.

[0023] FIG. 2 is a bottom perspective view of the tissue stabilizer of FIGS. 1A and 1B.

[0024] FIG. 3 is a cross-sectional view taken along line 3-3 as shown in FIG. 1A.

[0025] FIG. 4 is a cross-sectional view taken along line 4-4 as shown in FIG. 1A.

[0026] FIG. 5 is a bottom perspective view of an alternate construction of a tissue stabilizer according to the principles of the present invention.

[0027] FIG. 6 is an exploded perspective view of a tissue stabilizer.

[0028] FIG. 7 is an exploded perspective view of an alternate construction of a tissue stabilizer.

[0029] FIG. 8A is a magnified partial perspective view of a contacting surface of a preferred perforated screen for use in a tissue stabilizer.

[0030] FIG. 8B is a partial cross-sectional view showing the perforated screen configuration of FIG. 8A engaged against a tissue structure.

[0031] FIGS. 9A and 9B are partial cross-sectional views of a tissue stabilizer foot having a perimeter seal.

[0032] FIG. 10 is a partial cross-sectional view of a tissue stabilizer foot having an alternate perimeter seal.

[0033] FIG. 11 is a partial cross-section view of a tissue stabilizer foot having an alternate perimeter seal.

[0034] FIG. 12 is a top plan view of a tissue stabilizer having an alternative perimeter seal.

[0035] FIG. 13A is a top perspective view of the stabilizer foot of FIG. 12.

[0036] FIG. 13B is a cross-sectional view taken along line 13B-13B as shown in FIG. 13A.

[0037] FIG. 14 is a bottom perspective view of an alternate construction of a tissue stabilizer according to the principles of the present invention.

[0038] FIG. 15 is a cross-sectional view of one of the stabilizer feet of FIG. 14.

[0039] FIG. 16 is a bottom plan view of an alternate construction of a stabilizer foot according to the principles of the present invention.

[0040] FIG. 17 is a cross-sectional view taken along line 17-17 as shown in FIG. 16.

[0041] FIG. 18 is a bottom plan view of an alternate construction of a stabilizer foot.

[0042] FIG. 19 is a cross-sectional view taken along line 19-19 as shown in FIG. 18.

[0043] FIG. 20 is a bottom plan view of an alternate construction of a stabilizer foot.

[0044] FIG. 21 is a cross-sectional view taken along line 21-21 as shown in FIG. 20.

[0045] FIG. 22 is a partial cross-sectional view of an alternate construction of a tissue stabilizer according to the principles of the present invention.

DETAILED DESCRIPTION

[0046] The present invention involves surgical instruments and methods for stabilizing tissue during a surgical operation. The devices described herein may be used in a wide variety of surgical applications that require a tissue structure to be stabilized or immobilized to provide a substantially stable and motionless surgical field on which a surgical procedure can be performed. By way of example only, the preferred embodiments described in detail below are directed to the stabilization of a portion of the heart to facilitate a surgical procedure on or within the heart, such as a coronary artery bypass graft (CABG) procedure.

[0047] Although the devices and methods of the present invention may have application in both conventional stopped-heart and beating heart procedures, they are preferably used to stabilize the beating heart during a CABG operation which has been specially developed to facilitate completion of an anastomosis, typically between a target coronary artery and a bypass graft or source artery, without requiring cardiac arrest and cardiopulmonary bypass.

[0048] A typical beating heart CABG procedure involves accessing the beating heart by way of a sternotomy, mini-sternotomy, thoracotomy, mini-thoracotomy, or other suitable access incision, positioning a tissue stabilizer on, around or adjacent a coronary artery to stabilize the coronary artery, creating an arteriotomy in the coronary artery, and anastomosing the bypass graft or source artery to the arteriotomy.

Typically, the tissue stabilizer has a heart engaging member at one end for engaging the surface of the beating heart and is connected at the other end to a stationary object such as a sternal retractor, rib retractor, or other such stationary structure. Exemplar devices and methods for accessing the beating heart and mounting a stabilizer device are disclosed in co-pending U.S. patent application Ser. No. 09/305,810 titled "A SURGICAL RETRACTOR APPARATUS FOR OPERATING ON THE HEART THROUGH AN INCISION", the entirety of which is herein incorporated by reference.

[0049] The devices of the present invention involve tissue stabilizers which provide superior engagement with the surface of the heart. In preferred embodiments of the present invention, the tissue stabilizer may have one or more stabilizer feet which provide for adjustment of the orientation of the features which contact or engage the surface of the heart. In one instance, the orientation may be adjusted to ensure the engaging features will be properly aligned with the surface of the heart. In addition, once engaged with or connected to the heart, the orientation may be adjusted to yield an optimum presentation of the target coronary artery and, in particular, the location at which the anastomosis will be performed.

[0050] When the tissue stabilizer is configured to facilitate the use of negative pressure to engage the surface of the heart, the stabilizer feet may include one or more compliant or flexible seals to ensure that there will be no vacuum leaks between the stabilizer foot and the surface of the heart. To ensure that the engaging features provided on a stabilizer foot will closely approximate the surface of the beating heart under operating conditions, the stabilizer foot may have one or more portions which are adjustable relative to each other so that the stabilizer foot may be shaped according to the requirements of a particular surgical procedure or according to the specific anatomical features or characteristics of each individual patient.

[0051] Referring to the figures wherein like numerals indicate like elements, an exemplar tissue stabilizer is illustrated in FIGS. 1A-4. Tissue stabilizer **100** preferably has stabilizer feet **105** and **110** which typically engage the surface of the heart on opposite sides of a coronary artery. Tissue stabilizer **100** is typically positioned such that the coronary artery runs lengthwise in the space between stabilizer feet **105** and **110**.

[0052] For beating heart procedures where the target vessel is occluded, tissue stabilizer **100** preferably has a construction that does not occlude or otherwise contact the vessel as stabilizer feet **105** and **110** are placed on opposite sides of the coronary vessel portion to be stabilized. Thus, stabilizer feet **105**, **110** are spaced apart at a distance such that a coronary artery can be positioned therebetween. When stabilizer feet **105** and **110** are connected to a common base, the base may include a recessed or raised portion to ensure that the vessel is not contacted by the stabilizer. For example, manifold base **120**, to which stabilizer feet **105** and **110** are attached, preferably has raised portion **126** under which the coronary vessel may pass without contact when stabilizer feet **105** and **110** are engaged to stabilize the heart in the vicinity of the coronary vessel.

[0053] Stabilizer feet **105** and **110** are connected to manifold base **120** which will typically have mounting or connecting features for operably attaching a suitable shaft or other such structure. Preferably manifold base **120** has a ball **135** extending therefrom. A shaft (not shown), preferably having a suitably constructed socket, may be provided to engage ball **135**. The shaft may be used to position tissue stabilizer **100** at

the desired location on the heart and may provide the necessary structure to hold the tissue stabilizer substantially motionless against the forces generated by the beating heart. Of course, the shaft or other appropriate connecting structure may be operably connected to the tissue stabilizer using any suitable connection which allows the desired maneuverability of the tissue stabilizer relative to the shaft. Suitable stabilizer shafts and their connections to a tissue stabilizer are described in co-pending U.S. patent application Ser. No. 08/931,158, titled "SURGICAL INSTRUMENTS AND PROCEDURES FOR STABILIZING THE BEATING HEART DURING CORONARY ARTERY BYPASS GRAFT SURGERY", and in EPO Application 97102789.1, the entirety of each are herein incorporated by reference.

[0054] Stabilization of the targeted tissue may be achieved by applying a localized compressive force to the heart through stabilizer feet **105** and **110** using an appropriate connecting structure attached to ball **135**. In that case, the tissue contacting features on the bottom of stabilizer feet **105** and **110** are designed to have high friction against the surface of the heart, for example, by using a textured surface or the like. If desired, negative pressure or vacuum may be applied to stabilizer feet **105** and **110** so that the beating heart may be engaged or captured by the suction created within a vacuum chamber or a plurality of suction ports. With a localized portion of the beating heart so engaged against stabilizer feet **105** and **110**, the heart portion may be rendered substantially motionless by fixing an attached shaft to a stationary object, such as a surgical retractor as described above.

[0055] Continuing to refer to FIGS. 1A-4, ball **135** is preferably connected to manifold base **120** by way of post **130**. Ball **135** and post **130** may have any suitable construction which provides the necessary attachment of the stabilizing shaft or other stabilizing structure and which can withstand the loads required to stabilize the beating heart with minimal deflection. The ball and post may be integrally molded features on the manifold base itself or may be separate components mechanically secured to manifold base **120** using, for example, a threaded or snap-fit connection or the like.

[0056] When manifold base **120** is constructed of a plastic material, it may be desirable to fix post **130** to a relatively rigid support member to help spread stabilization loads transmitted through post **130** over a larger area of manifold base **120**. Preferably, post **130** is rigidly attached to support member **155** which is made of a metal such as aluminum or stainless steel. In a preferred embodiment, support member **155** is secured within holding features such as cavities or pockets **156** and **158** formed in rear manifold portion **124** and front manifold portion **122**, respectively. Support member **155** may be secured within pockets **156** and **158** by a simple interference fit as manifold portions **122** and **124** are urged into their final assembled positions or may be held in place using mechanical fasteners, adhesive, or suitable bonding or welding technique.

[0057] When the tissue stabilizer is configured to use vacuum stabilization or vacuum-assisted stabilization, manifold base **120** preferably has a fitting or the like to which a vacuum supply may be connected. In a preferred embodiment, manifold base **120** has inlet tube **115** having an inlet opening **117**. Inlet tube **115** is preferably in fluid communication with a hollow space or chamber **134** formed within manifold base **120**. Manifold base **120** and internal chamber **134** provides for convenient distribution of a single vacuum source connected to inlet tube **115** to multiple stabilizer feet

fluid connections, in this case to stabilizer feet **105** and **110**. Inlet tube **115** may have one or more barbs **119** to facilitate the secure and leak-free attachment of a length of flexible tubing (not shown) coming from a vacuum pump or other vacuum source (not shown) as is commonly known in the art. In an alternative embodiment, inlet tube **115** may be replaced with a generally cylindrical bore adapted to accept an O-ring sealed fitting forming a dynamically sealed rotating connection between the fitting and the manifold base similar in construction to the stabilizer foot connection described below with regard to FIG. 3.

[0058] For ease of manufacturing, manifold base **120** is preferably made in two or more portions and fixed together to form a sealed, hollow interior. In a preferred embodiment, manifold base **120** has front manifold portion **122** and rear manifold portion **124** which may be bonded together along bond line **125** as shown. The internal chamber **134** may reside primarily in either or both of front and rear manifold portions **122** and **124**. To maximize the volume of internal chamber **134** for a given outer-profile of manifold base **120**, a portion of internal chamber **134** is formed in rear manifold portion **124** and one or more internal cavities **128** are included within front manifold portion **122**.

[0059] The manifold portions are preferably injection molded and may be fixed together using standard mechanical fasteners, a snap fit construction, or any suitable adhesive, bonding, sealing, or welding technique compatible with the material of manifold base **120**. To facilitate reliable bonding between the manifold portions, the manifold portions may have close fitting overlapping flanges. In a preferred embodiment, best illustrated in FIG. 3, rear manifold portion **124** has an inner flange **152** and front manifold portion **122** has an overlapping outer flange **154**. This construction provides a particularly reliable sealed junction between front and rear manifold portions **122** and **124**, especially when used in conjunction with a suitable gap-filling adhesive.

[0060] As mentioned above, stabilizer feet **105** and **110** are secured to manifold base **120**. Stabilizer feet **105** and **110** may be fixed in place in any convenient manner and immovable relative to manifold base **120**. More preferably, however, stabilizer feet **105** and **110** are moveable relative to manifold base **120**. Most preferably, stabilizer feet **105** and **110** are independently moveable with respect to each other as well. This allows the tissue engaging features of the tissue stabilizer to be optimally adjusted with respect to the size and shape of the tissue to be stabilized and, once engaged and in operation, may also allow the stabilizer feet to be moved to optimize the presentation of the stabilized tissue, and more particularly the target coronary artery.

[0061] In a preferred embodiment, stabilizer feet **105** and **110** are connected to manifold base **120** in a manner which allows each foot to rotate relative to the manifold base **120**. The axis about which the stabilizer feet **105** and **110** rotate may be in any orientation that provides the desired stabilizer feet orientation relative to the heart for optimum engagement or tissue presentation. Typically, the axis of rotation is oriented generally in the same direction as the direction stabilizer feet **105** and **110** extend from manifold base **120**, although the axis of rotation and the direction the stabilizer feet extend may be offset from each other. Thus, the axis of rotation of the first stabilizer foot relative to the base member may be offset from the axis of rotation of the second stabilizer foot relative to the base member.

[0062] In a preferred embodiment, the axis of rotation is preferably at an angle of no more than about 25° with respect to the included plane or surface approximated by the features adapted to engage the tissue surface to be stabilized. More preferably, the axis of rotation for each stabilizer foot 105 and 110 is generally parallel to the features adapted to engage the tissue surface to be stabilized. When the tissue engaging features are curved to have a radius of a constant or varied radius or an otherwise non-planar, the axis of rotation is oriented as described above relative to a best-fit plane approximating the tissue engaging features or a central tangent plane. Most preferably, the axis of rotation for each stabilizer foot is also angled with respect to each other at an angle of no more than about 30°, and more typically the axis of rotation of stabilizer foot 105 is generally parallel to the axis of rotation of stabilizer foot 110.

[0063] Referring to FIG. 3, a preferred stabilizer foot connection is illustrated with respect stabilizer foot 110. Manifold base 120, and more specifically front manifold portion 122, has a bore 149 extending through the exterior wall. Stabilizer foot 110 has an end portion or fitting 137 having an outside diameter 148 adapted to mate with bore 149 to allow fitting 137, and thus stabilizer foot 110, to rotate about central axis 133 of bore 149. In the configuration shown, central axis 133 is offset from the features which engage the tissue to be stabilized, in this case perforated screen 141. This offset facilitates improved vessel presentation as stabilizer feet 105 and 110 are rotated because, in addition to changing the overall orientation of the tissue engaging features, the eccentric relation of the tissue engagement features relative to the central axis moves the stabilizer feet together or apart as the stabilizer feet are rotated. This action allows the tissue and included coronary artery held between the stabilizer feet to be stretched or compressed as desired by rotating either or both of stabilizer feet 105 and 110 after they have become operably engaged with the tissue.

[0064] In a preferred embodiment of the present invention, the tissue stabilizer 100 is constructed to supply a negative pressure or vacuum to stabilizer feet 105 and 110 to assist in the engagement of the surface of the heart. Stabilizer feet 105 and 110 preferably have a hollow interior 132 to which a vacuum may be supplied through vacuum inlet 131 of fitting 137, vacuum chamber 134, and vacuum inlet tube 115, which are interconnected in a manner which does not allow any significant vacuum leaks. Collectively, the structures comprise a vacuum conducting chamber that communicates a negative pressure from a vacuum source to the surface of the beating heart. Vacuum inlet tube 131 may optionally have restriction or aperture (not shown) provided therein to restrict the amount of flow through vacuum inlet tube 131 when the sealed engagement against the tissue to be stabilized is broken. This allows vacuum chamber 134 of manifold base 120 to continue to provide sufficient vacuum to one stabilizer foot even when the engagement seal of the other stabilizer foot is compromised.

[0065] To allow vacuum to be communicated to the engagement features of stabilizer feet 105 and 110, the rotating connection between stabilizer feet 105 and 110 and manifold base 120 must be sealed to prevent any vacuum loss. This preferably accomplished using an appropriate dynamic annular or shaft seal that seals between the stabilizer foot and manifold base 120 but yet allows for rotation of the stabilizer foot within bore 149 without incurring any vacuum loss. Preferably, a seal such as O-ring 145 is positioned within an

annual seal cavity 146 at the entrance of bore 149. The seal is captured and compressed within seal cavity 146 by cooperating annular seal flange 147 provided on stabilizer feet 105 and 110 as the stabilizer feet are urged into final position. Stabilizer feet 105 and 110 may be held in position by operation of a spring clip or e-clip 150 assembled to fitting 137 just beyond its exit of bore 149.

[0066] Hollow interior 132 is generally a closed chamber except for one or more openings for engaging the heart. As will be discussed in more detail below, the engagement opening or openings may be in the form of a perforated screen having a relatively large number of perforations or small holes which engage the surface of the heart, a single opening having a defined perimeter for sealing against the surface of the heart, or a plurality of individual suction pods each having a sealing perimeter.

[0067] Referring to FIGS. 2 and 3, stabilizer feet 105 and 110 include thin perforated sheets or screens 140 and 141, respectively which have a front surface 144 oriented to engage the surface of the heart. Perforated screens 140 and 141 are supported around their perimeter by a support step 138 which preferably has a raised perimeter edge or border 139. Perforated screens 140 and 141 are characterized as having a plurality of perforations or holes 142. Preferably, perforated screens 140 and 141 are fabricated to have a contour or shape which corresponds to the expected size and shape of the cardiac tissue to be stabilized. For example, perforated screen 140 and 141 may have a radius, R, which may be constant or variable.

[0068] As front surfaces 144 of perforated screens 140 and 141 are urged against the surface of the heart (or other tissue structure), the heart begins to contact front surface 144 around each perforation 142 and thus sealingly covering each perforation 142. As each perforation 142 is covered in this manner, the relatively small portion of tissue residing over each perforation 142 is subjected to the vacuum existing within hollow interior 132 and is accordingly sucked against, and even slightly into, perforation 142.

[0069] Because the total vacuum or suction force applied to the tissue is a function of the total tissue area exposed to vacuum, it is desirable for screens 141 and 142 to have the aggregate area of all the perforations as great as possible and still maintain the required structural integrity. In a preferred embodiment, the unperforated material between adjacent perforations is between about 0.015 inches (0.38 mm) and about 0.025 inches (0.635 mm) at its smallest point, most preferably about 0.02 inches (0.51 mm), and the diameter of the perforations are from about 0.06 inches (1.524 mm) to about 0.09 inches (2.286 mm).

[0070] A particularly advantageous configuration of front surface 144 includes a plurality of projections or protrusions disposed at a number of locations between the holes or perforations. FIGS. 8A and 8B illustrate a perforated member 400 having a front contact surface 410 which has a number of perforations or holes 415. The unperforated material of member 400 has a plurality of projections 420 extending outwardly from contact surface 410. In a preferred embodiment, a plurality of projections are generally equally spaced around each perforation 415. The projections may be formed, for example, by chemical machining or etching. Projections 420 operate to more aggressively bite or engage tissue structure 425 as it is urged into perforation 415 by operation of an applied vacuum.

[0071] In the embodiments shown in FIGS. 2 and 3, the outermost extending surface of border 139 is generally even or flush with front surface 144 of perforated screens 140 and 141. To maximize the total area of tissue exposed to vacuum, it may be desirable to have a raised border or perimeter which exposes and subjects all the tissue within its boundary to the negative pressure supplied through the interior of the stabilizer feet. FIG. 5 illustrates tissue stabilizer 200 having a perimeter sealing member 215 disposed at the bottom of each stabilizer foot 205 and 210. Perforated screens 140 and 141 are recessed from perimeter sealing member 215.

[0072] When perimeter sealing member 215 makes contact with the surface of the heart around substantially its entire perimeter, the portion of the heart tissue within the perimeter is subjected to the negative pressure existing within the hollow interior of stabilizer feet 205 and 210 and is urged into engagement with stabilizer feet 205 and 210. The negative or vacuum pressure may be sufficient to displace the portion heart tissue within the vacuum chamber created by perimeter sealing member 215 into forced contact with perforated screens 140 and 141. To further increase traction, perforated screens may optionally have projections as described above.

[0073] An exploded view of tissue stabilizer 200 is shown in FIG. 6. Front manifold portion 122 has first and second bores 222 and 223 for receiving tubular members or fittings 208 associated with stabilizer feet 205 and 210, respectively. Fittings 208 are preferably integrally molded features of stabilizer feet 205 and 210, but could alternatively be separate fittings secured to the stabilizer feet by way of, for example, a bonded, welded, or threaded connection. Fittings 208 have a flange 212 for retaining and compressing O-ring 202 within the seal cavity (not visible in this view) and groove 214 for receiving an external retaining ring, preferably of the spring type, e-type or the like. Fittings 208 preferably have a vacuum inlet opening 220 for communicating the negative pressure within manifold base 120 to the hollow interior region within stabilizer feet 205 and 210.

[0074] The multifunctional components of tissue stabilizer 200 allow for simple and convenient assembly. Stabilizer foot 205 may be assembled to front manifold portion 222 by installing O-ring 202 over fitting 208 and then installing fitting 208 through bore 222. Fitting 208 and stabilizer foot 205 is secured in place by securing an external retaining ring 218, into place within groove 214. The same procedure is then used to install stabilizer foot 210 to manifold portion 222. Post support member 155 is placed in the proper location between or within front and rear manifold portion 122 or 124 as the two manifold portions are brought together in the presence of an appropriate bonding agent or adhesive to make the assembly leak-free, air-tight, and permanent. Perforated screens 140 and 141 may be secured to stabilizer feet 205 and 210 at any convenient time before or after the assembly procedure just described.

[0075] Tissue stabilizer 300, shown in exploded view in FIG. 7, allows stabilizer feet 305 and 310 to be assembled to front manifold portion 122 using a simple snap-fit construction instead of an external retaining ring. In this variation, the fitting portions of stabilizer feet 305 and 310 include a seal flange 310, an uninterrupted base portion 304 and a number of flexures 302 having raised end features 303. Flexures 302 allow raised features 303 to flex inwardly so that they fit through bore 222 and 223 and then flex outwardly as they exit bores 222 and 223, thus becoming locked in place.

[0076] Tissue stabilizer 300 may be assembled using the same basic procedure as described above with reference to tissue stabilizer 200. In addition, however, because there is no retaining feature to be installed to the fitting portion after placement through bores 222 and/or 223, the front and rear manifold portions 122 and 124 can be fully assembled and leak tested (if desired) before stabilizer feet 305 and 310 are installed. Thus, post support member 155 is positioned in place in or between front and rear manifold portions 122 and 124 as the two manifold portions are brought together in the presence of an appropriate bonding agent or adhesive to secure the manifold base assembly together. An O-ring 202 is then placed over uninterrupted portion 304 adjacent flange 310 and raised features 303 on flexures 302 are urged through bore 222 or 223 until it exits the bore and snaps open and into place, thus fixing stabilizer foot 305 or 310 to the assembled manifold base.

[0077] Tissue stabilizer 300 shows a variation in which a stabilizer shaft 307 is pre-installed on ball 135. Stabilizer shaft 307 has a socket housing 306 which is permanently operably attached to ball 135. The ball 135 and post 130 is dropped into housing 306 from a distal direction prior to fixing shaft 307 thereto. Post support member 155 is then fixed to the proximal end of post 130, rendering the assembly essentially inseparable. This eliminates any possibility of accidental separation of the stabilizer foot from the stabilizer shaft.

[0078] To gain the advantage of stabilizer feet having different constructions for different procedures or patients, the foregoing design allows the desired stabilizer feet to simply be snapped into place within bores 222 and 223, for example, after a clinical determination has been made regarding what size, type, etc. of stabilizer feet will be presently required. Once snapped into place, stabilizer feet 305 and 310 may be rotated to obtain the desired orientation of each foot to provide maximum stabilization based on the clinical situation presented by an individual patient.

[0079] Stabilizer feet 305 and 310, or any of the other stabilizer feet described herein, may be provided with additional features to facilitate adjustment of stabilizer feet 305 and 310 after engagement with the tissue to be stabilized. The features may be any holes, lever, protrusion, projection, or other suitable feature that allows the stabilizer feet to be easily manipulated during use. Since it is desirable for the device to have an unobstructingly low-profile, especially in the area of the stabilizer feet, the adjustment features are preferably one or more blind holes 308 adapted to receive a blunt instrument for manipulating the orientation of stabilizer feet 305 and 310. Alternatively, a hex or nut-shaped feature could be added to each stabilizer foot distal of the seal flange for use with an appropriately sized wrench or the like to rotate the stabilizer feet.

[0080] Perimeter sealing member 215 may have a variety of constructions. Sealing member 215 may simply be an integral extension of the stabilizer foot material. In that instance, sealing member 215 will typically be a relatively hard polymer or plastic material. Sealing member 215 may also be a relatively soft elastomer which is attached to or over-molded on stabilizer feet 205 and 210. Sealing member 215 may also be constructed of a compressible foam material, preferably a closed cell foam. The elastomer or foam materials will preferably compress, deflect or otherwise yield somewhat as the stabilizer feet become engaged with the irregular surface of the heart. When sealing member 215 is constructed of an

elastomer or foam material, it will preferably have a durometer hardness in the range from about 35 Shore-A to about 100 Shore-A depending on the geometrical configuration of sealing member 215.

[0081] In a preferred embodiment, the perimeter seal has a variable thickness around its perimeter to provide a more reliable seal against the curvature of the surface of the heart, especially when the heart continues to beat during the procedure. FIGS. 9A and 9B show a portion of a stabilizer foot 430 having a perimeter seal 440 with a variable height or thickness around its perimeter. Similar to the previously discussed configurations, stabilizer foot 430 has a hollow interior 449 to which a negative pressure is communicated. Perforated screen 435 has a plurality of holes or perforations 437 and is mounted in position on step feature 447 within stabilizer foot 430. Perimeter seal 440 is mounted at or near the bottom of stabilizer foot 430, and is preferably retained within a groove or step 448.

[0082] The height that perimeter seal 440 extends from the bottom of stabilizer foot 430, typically varies at different locations around the perimeter of perimeter seal 440. For example, the tip height 441 and rear height 443 is generally greater than midpoint height 442 along either side of the stabilizer foot. In addition, height 446 of perimeter seal 440 along the inside of stabilizer foot 430, that is the side closest to the target artery, is generally less than the outside height 444 at a corresponding location along the stabilizer foot 430.

[0083] The variable height results in a contoured shape of perimeter seal 440 which tends to remain sealed against the heart when the heart expands and contracts as it beats to pump blood. In a preferred embodiment perimeter seal 440 is made from an elastomer, a closed-cell foam, or other flexible or compressible material to further optimize the ability of stabilizer foot to maintain its seal on the tissue to be stabilized. If the seal is broken or otherwise compromised, the stabilizer foot may disengage from the surface of the heart, adversely affecting stabilization. Seal 440 may be fixed to the stabilizer foot using an adhesive or bonding agent or may be made integral with the stabilizer foot using an injection over-molding process wherein seal 440 is molded over the stabilizer foot.

[0084] Another seal variation is illustrated with reference to stabilizer foot 450, a portion of which is shown in FIG. 10. Stabilizer foot 450 again has a hollow interior 449 and a perforated screen 435 having perforations or holes 437. In this variation, stabilizer foot 450 has a flexible seal 455 having first and second legs 458 and 459 disposed in an angular relationship which operates as a highly flexible joint allowing perimeter edge 456 to move relatively freely towards and away from the bottom of stabilizer foot 450 as required to effectuate a reliable seal against the surface of the tissue to be stabilized. For example, if the tissue under vacuum engagement with stabilizer foot 450 contracts and moves away from the tip of stabilizer foot 450, flexible seal 455 can easily follow the movement to a new extended position 4551 without the seal being broken.

[0085] Flexible seal 455 is preferably made from a medical grade elastomeric material such as silicone, urethane rubber, neoprene, nitrile rubber, hytrel, kraton, or other suitable material. Flexible seal 455 may be separately formed and later attached to stabilizer foot 450 or may be integrally over-molded onto stabilizer foot 450. For secure attachment to stabilizer foot 450, flexible seal 455 may optionally be provided with seal base portion 457.

[0086] If greater extension of the flexible seal's perimeter sealing edge away from the stabilizer foot is required, a seal having a greater number of flexible legs in a bellows or accordion type arrangement is employed. Referring to FIG. 11, stabilizer foot 460 has flexible seal 465 having continuously connected alternating flexible legs in the form of a bellows. Flexible seal 465 may include a base 467 to facilitate attachment to the bottom of stabilizer foot 460 and has a perimeter edge 466 to effectuate a reliable seal against the surface of the tissue to be stabilized. This type of seal generally compresses to a relatively solid, stable structure as the stabilizer foot is urged against the surface of the tissue, has the ability to follow moving tissue over a relatively long travel if required, and yet occupies only a very small amount of space around the perimeter of the stabilizer foot.

[0087] Another flexible seal arrangement is illustrated in FIGS. 12-13B with reference to tissue stabilizer 470. Tissue stabilizer 470 has a manifold base 473 comprised of front manifold portion 472, rear manifold portion 474 having vacuum inlet tube 471, and ball 476 to which a stabilizing shaft may be attached. Stabilizer feet 475 and 480 may be attached to stabilizer base 473 in any of the ways discussed above. Most preferably, stabilizer feet 475 and 480 have a fitting portion 485 which includes an uninterrupted cylindrical portion 486, one or more flexures 487 each having raised features 488 that provide a positive snap-fit joint in cooperation within cylindrical bores formed in front manifold portion 472 as described in detail above. Preferably, fitting 485 has a flange 479 for retaining and compressing a shaft seal or the like.

[0088] Stabilizer feet 475 and 480 have attached thereto flexible seals 482 and 477, respectively. Flexible seals 477 and 482 may extend completely around the perimeter of stabilizer feet 480 and 475. More preferably, stabilizer feet 475 and 480 have at least one portion of its perimeter having a flexible seal and at least one portion without a flexible seal. According to this variation of the present invention, the stabilizer feet 475 and 480 are primarily sealed against the target tissue by operation of their own perimeter edge 481. Flexible seals 482 and 477 are provided generally outside of perimeter edge 481 to provide a form of secondary or back-up seal in the event the seal at perimeter edge 481 becomes compromised as a result of misalignment or movement of the tissue. Flexible seals 477 and 482 are preferably sufficiently flexible to remain in contact with the movements of the beating heart so that when the seal breaks along 481 perimeter edge the vacuum loss is contained within flexible seal 482 or 477. This containment typically allows the comprised area of perimeter edge 481 to become re-engaged against the tissue without significant vacuum loss.

[0089] After engagement and stabilization of the beating heart, the vacuum seal formed at the perimeter edge of the stabilizer feet may be most likely to break at the tip region or along the outside edge of the stabilizer foot as the heart contracts away from the site of stabilization. In such circumstances, flexible seals 477 and 482 need only be associated with these problem areas, leaving inside perimeter portion 478 and the space between stabilizer feet 475 and 480 open to avoid obstructing the surgical field of the anastomosis. Flexible seals 477 and 482 have a contoured outer periphery 483 which may be a relatively large distance away from the outer extents of the stabilizer feet 475 and 480 and may include extended tip portions 484. Flexible seals 477 and 482 preferably have a top portion for attaching to the stabilizer feet

about the perimeter edge **481**. Flexible seals **477** and **482** may be fixed in place using an adhesive or bonding agent or may be integrally over-molded as part of stabilizer feet **475** and **480**.

[0090] Another way to prevent a complete loss of engagement and stabilization of the target tissue due to a compromised perimeter seal resulting from misalignment of the stabilizer feet or movement of the target tissue to be stabilized, is to partition the vacuum chamber within the stabilizer feet into a plurality of chambers connected to the vacuum source through only a small aperture. In that way, a vacuum leak at a single location will result in a reduced ability to maintain engagement of that partitioned section only and will not immediately compromise the engagement of the entire stabilizer foot. Of course, it may be desirable to combine any one of the flexible seals described above with partitioning to further increase the reliability of the stabilizer foot seal against the tissue structure to be stabilized.

[0091] A tissue stabilizer embodiment having stabilizer feet with a partitioned vacuum chamber is illustrated in FIGS. **14** and **15**. Tissue stabilizer **500** has a manifold base **501**, preferably having front and rear manifold portions **504** and **502**, to which first and second stabilizer feet **505** and **506** are attached. First and second stabilizer feet **505** and **506** have perimeter seal edges **507** and **508** which generally define the extents of the vacuum chambers for each stabilizer foot. One or more partitions **509**, each having a sealing edge **511**, are provided to divide stabilizer feet **505** and **506** into two or more vacuum subchambers. By way of example only, stabilizer feet **505** and **506** have partitions **509** which divide the vacuum space into first, second, third, and fourth vacuum subchambers **517**, **518**, **549**, and **520**, respectively.

[0092] Vacuum feed tube **510** is provided along the interior of stabilizer feet **505** and **506** to communicate the negative pressure from within the manifold base to each of subchambers **517**, **518**, **519**, and **520**. Vacuum feed tube **510** preferably has a side opening or aperture **512** within each of subchambers **517**, **518**, and **519**. Vacuum feed tube **510** may have an end opening or aperture **513** within subchamber **520**. The apertures **512** and **513** facilitate the separate communication of negative pressure to each vacuum subchamber and are preferably sized such that when one subchamber encounters a vacuum leak, the aperture is restricted enough so that the vacuum in the other subchambers can be maintained by the vacuum source.

[0093] Stabilizer feet **505** and **506** are preferably rotatable with respect to manifold base **501** as discussed at length above. For example, stabilizer feet **505** and **506** may have a fitting portion **515** which is preferably cylindrical to cooperate with a mating bore provided in manifold base **501**. Fitting portion **515** may have a flange **514** for retaining a shaft seal and a groove for receiving an external retaining ring to secure fitting portion **515** within manifold base **501**. The bottom of stabilizer feet **505** and **506** may have a contoured shape having a variable or fixed radius, *R*. A flexible seal may optionally be included along one or all of sealing edges **507**, **508**, and **511**.

[0094] A partitioned vacuum chamber as described above maximizes the area exposed to negative pressure for a particular size of stabilizer foot. That is, the ratio of the surface area exposed to negative pressure divided by the total surface area included with the boundary at the bottom of the stabilizer foot is maximized by the partitioned chamber configuration just described. In another embodiment, although less efficient in that regard, rotatable stabilizer feet can be constructed to have a number of individual vacuum ports or pods.

[0095] FIGS. **16** and **17** illustrate stabilizer foot **550** having a plurality of individual vacuum ports. By way of example

only, stabilizer foot **550** has four suction ports **551**, **552**, **553**, and **554** each with a dedicated edge seal **561**. Negative pressure is communicated to each port through openings or apertures **560** provided in vacuum distribution passage **563** which is fluid communication with vacuum inlet **562** which in turn is placed in fluid communication with the negative pressure within a manifold base assembly having a construction as described above. Stabilizer foot **550** may be mounted for rotation within a cooperating bore of an appropriate manifold base by way of cylindrical fitting portion **556** which may include a seal flange **555** and groove **557** for receiving an external retaining ring to secure fitting portion **556** in place.

[0096] FIGS. **18** and **19** show a variation of a stabilizer foot having a plurality of individual ports. Stabilizer foot **575** again has a fitting portion **599** having a seal flange **598** for retaining and compressing an appropriate shaft seal to provide the desired dynamic seal as stabilizer foot **575** is rotated about fitting portion **599**. To facilitate even greater adjustment of the shape and orientation of stabilizer foot **575** has a first foot portion **580** with at least one vacuum port and a second foot portion **585** with at least one vacuum port which are adjustable relative to one another, preferably by way of one or more malleable joints or links.

[0097] In a preferred embodiment, first foot portion **580** has a plurality of separate vacuum ports **581** each with a perimeter seal **582**. Preferably, first foot portion **580** has three vacuum ports **581** each supplied with negative pressure through apertures **578** in vacuum distribution channel or passage **593**. Second foot portion **585** has at least one vacuum port **583** having perimeter seal **584** and aperture **577** in fluid communication with vacuum passage **592**. First foot portion **580** and second foot portion **585** are preferably connected to each other by malleable tube **590**, which has a lumen or passage **591** therethrough. Malleable tube **590** is preferably made of stainless steel, more preferably annealed stainless steel or vacuum annealed stainless steel.

[0098] With this configuration, the vacuum communicated from a manifold base or other vacuum source through vacuum inlet channel **595** is distributed to vacuum ports **581** and **583** through vacuum distribution channel **593** and associated apertures **578**, through malleable tube passage **591**, finally to vacuum passage **592** and associated aperture **577**. The orientation of second foot portion **585** and thus vacuum port **583** can be adjusted relative to first foot portion **580** by simple bending it to the desired orientation. This additional adjustment tends to eliminate problems associated with obtaining a reliable seal at the tip of the stabilizer foot as the beating heart contracts away from the stabilizer, yet maintains the reliability of having ports **603** molded to a unitary relatively rigid stabilizing structure.

[0099] Malleable tube **590** may be secure to first foot portion **580** and second foot portion **585** in any convenient manner which provides a permanent and sealed connection. Preferably, the exterior of malleable tube **590** may be pressed into mating counterbores **596** and **597** provided in the ends of Vacuum passages **593** and **592** as shown. A suitable adhesive or bonding agent may additionally be used to sealingly secure malleable tube **590** in place. Alternatively, malleable tube **590** and counterbores **596** and **597** may be threaded together or malleable tube **590** could be insert molded within first and second foot portions **580** and **585**.

[0100] FIGS. **20** and **21** illustrate another embodiment of a stabilizer foot having foot portions which are adjustable relative to one another to improve the fit, and accordingly the operating vacuum seal, against the surface of the tissue structure to be stabilized. Stabilizer foot **600** has a first foot portion **601** and a second foot portion **602**. First foot portion **601** has

one or more, preferably three, vacuum ports **603** and second foot portion **602** has one or more vacuum ports **608**. Each of vacuum ports **603** and **608** preferably have a flexible or compressible perimeter seal **604** and **609**, respectively, preferably made of a medical grade elastomer or foam. Negative pressure is supplied to vacuum ports **603** and **608** through openings or apertures **715** and **716** which in fluid communication with vacuum passages **711** and **712**. Negative pressure is supplied to vacuum passage **711** through inlet channel or passage **710** of fitting portion **718**. Fitting portion **718** connected to a vacuum chamber or source within a manifold base or like structure as described above.

[0101] First foot portion **601** and second foot portion **602** are made adjustable relative to each other by providing one or more malleable links spanning between the two portions. In one variation, first and second malleable members **606** and **607** are located off-center with respect vacuum ports **603** and **608**. The off-center position of malleable members **606** and **607** better protects against excessive torsional loads applied to tube **605** if second foot portion **602** were twisted relative to first foot portion **601**.

[0102] Malleable members **606** and **607** may be glued or bonded within cavities or bores provided within first and second foot portions **601** and **602** or may be insert molded during fabrication of the foot portions. Tube **605** fluidly connects vacuum passages **711** and **712**. In this case, tube **605** may be malleable or may be a flexible tubing material. Preferably, tube **605** is assembled within counterbores **713** and **714**.

[0103] In operation, the tissue stabilizers of the present invention allow the stabilizer feet, and in particular the features which operate to engage the surface of the tissue to be stabilized, to be optimally adjusted to for a specific surgical procedure or to adjust for variations in size and orientation of a patient's anatomy. In addition, the stabilizer feet can be adjusted after engagement to the tissue to be stabilized to produce an improved presentation of the tissue subject to the surgical procedure.

[0104] In a preferred method of operation for a tissue stabilizer having first and second rotatable stabilizer feet connected to a manifold base having a stabilizer shaft attached thereto, one or both of the stabilizer feet are adjusted to the desired orientation relative to the manifold base and each other. Preferably, the orientation of the stabilizer feet are adjusted to account for the size and shape of the tissue to be stabilized, for example a target site on the surface of the heart. If either of the stabilizer feet have an adjustable portion, it may also be adjusted at this time. Next, the tissue stabilizer is brought into engagement with the tissue to be stabilized and the vacuum is applied. The stabilizer shaft is then locked into place to immobilize the tissue stabilizer and the engaged tissue. With the surgical site now relatively motionless, one or both of the stabilizer feet may be rotated relative to the manifold base until the tissue between or adjacent the stabilizer feet obtains the best possible presentation for the procedure to be performed. If there appears to be any discernible vacuum leaks associated with the engagement of the stabilizer feet against the target tissue, the orientation of the stabilizer feet may be further adjusted or, if applicable, the feet portions may be adjusted, to eliminate or minimize vacuum leaks at the interface between the stabilizer feet and the target tissue.

[0105] Although the illustrative stabilizer feet described above have been primarily directed to embodiments configured for connection to a common manifold base, the stabilizer feet of the present invention will operate with equal benefit when connected to any number of alternative structures. For example, FIG. 22 illustrates tissue stabilizer **725** having a

stabilizer foot rotatably connected with respect to a portion of common tubing having a flared end. Tube **740** may be a malleable tube, for example made of annealed stainless steel, which may be connected proximally to a manifold (not shown) shared with a second stabilizer foot or may be connected directly to a fixed mount (not shown) to effectuate stabilization.

[0106] In a preferred embodiment, stabilizer foot **730** is connected to housing **735** which rotates about tube **740**. Tube **740** has a flared end **742** as is commonly known in the art. A shaft seal, such as O-ring **732**, is placed over tube **740** adjacent flared end **742**. Housing **735** has a first bore **737** and a second larger bore **738**. First bore **737** is larger than the outside diameter of tube **740** but preferably smaller than the diameter of flanged end **742**. Second bore **738** is preferably slightly larger than flanged end **742**. Tube **740** with O-ring **732** is assembled through second bore **738** until the O-ring is compressed at the distal entrance to first bore **737**. An O-ring cavity **736** may be provided if desired. Fitting portion **734** is inserted into second bore **738** and permanently fixed in place preferably using a fluid tight connection such as pipe threads, adhesive, bonding agent, welding, brazing, etc. With fitting portion **734** fixed to housing **735**, stabilizer foot **730** and housing **735** may be rotated relative to tube **740** without any appreciable vacuum leakage. Stabilizer foot **730** may be of any desirable configuration.

[0107] While certain embodiments are illustrated in the drawings and have just been described herein, it will be apparent to those skilled in the art that many modifications can be made to the embodiments without departing from the inventive concepts described. For purposes of illustration only, the principles of the present invention has been described with reference to stabilizing the heart during a coronary artery bypass procedure but may readily be applied to other types surgical procedures on various types of tissue structures not specifically described. Many other uses are well-known in the art, and the concepts described herein are equally applicable to those other uses. Further, the different components and their equivalents of the various exemplar embodiments described above can be combined to achieve any desirable construction.

1-42. (canceled)

43. A device for stabilizing tissue within a patient's body, said device comprising:

a base member defining a base vacuum chamber and having a distal surface; and

at least one elongated stabilizer foot extending outwardly from said distal surface of said base member in a first direction and fluidically connected with said base vacuum chamber, said at least one stabilizer foot being rotatable, in its entirety, relative to said base member about an axis of rotation.

44. The device according to claim 43, wherein said stabilizer foot is connected to said base member through a dynamically sealed rotating connection.

45. The device according to claim 44, wherein connection allows for rotation of said stabilizer foot without incurring any vacuum loss.

46. The device according to claim 45, wherein said stabilizer foot may be rotated without incurring any vacuum loss when said stabilizer foot is operably engaged to tissue.

47. The device according to claim 44, wherein said connection is a dynamic annular or shaft seal that allows for rotation of said stabilizer foot without incurring any vacuum loss.

48. The device according to claim 43, wherein said axis of rotation is oriented in substantially the same direction as said first direction.

49. The device according to claim 43, wherein said axis of rotation is oriented at an angle of no more than about 25 degrees to said first direction.

50. The device according to claim 43, wherein said stabilizer foot comprises features adapted to engage a surface of the tissue, said features approximating the surface, and wherein said axis of rotation is angled with respect to said surface.

51. The device according to claim 43, wherein said elongated stabilizer foot comprises a hollow chamber extending substantially over the length of said elongated stabilizer foot.

52. The device according to claim 43, wherein said device comprises two elongated stabilizer feet.

53. The device according to claim 43, wherein said at least one elongated stabilizer foot comprises a tissue engaging feature with a non-planar perimeter.

54. The device according to claim 53, wherein said tissue engaging feature has a constant radius of curvature.

55. The device according to claim 53, wherein said tissue engaging feature has variable radius of curvature.

56. A device for stabilizing tissue within a patient's body, said device comprising:

a base member defining a base vacuum chamber and having a distal surface; and

at least one elongated stabilizer foot comprising a plurality of individual vacuum ports said stabilizer foot extending outwardly from said distal surface of said base member in a first direction and fluidically connected with said base vacuum chamber, said at least one stabilizer foot being rotatable, in its entirety, relative to said base member about an axis of rotation which is oriented in substantially the same direction as said first direction. (page 30 lines 8-10).

57. The device of claim 56, wherein said individual vacuum ports independently engage said tissue.

58. The device of claim 57, wherein each of said individual vacuum ports has a compressible perimeter seal.

59. The device of claim 56, wherein said elongated stabilizer foot comprises a first foot portion comprising at least one vacuum port and a second foot portion comprising at least one vacuum port, wherein said first and said second foot portions are adjustable relative to one another.

60. The device of claim 59, wherein said first and said second foot portions are adjustable relative to one another by way of one or more malleable joints.

61. The device of claim 59, wherein said first and said second foot portions are rigid.

62. The device of claim 56, wherein said elongated stabilizer foot is rotatably mounted on said base member and rotation of said stabilizer foot does not incur any vacuum loss.

63. A device for stabilizing tissue within a patient's body, said device comprising:

a base member; and

an elongated stabilizer foot extending outwardly from said base member in a first direction and fluidically connected with said base member, said foot having non-planar tissue-engaging features, said foot being rotatable, in its entirety, relative to said base member, about an axis of rotation.

64. The device of claim 63, wherein said axis of rotation is oriented relative to a best-fit plane approximating the tissue engaging features.

65. The device of claim 63, wherein said axis of rotation is oriented relative to a central tangent plane of the tissue engaging features.

66. The device of claim 63, wherein said base is a common tube.

67. The device of claim 66, wherein said device further comprises a housing connected to said foot which rotates around said base.

68. The device of claim 63, wherein said tube is flanged, and said tube is connected to said base member using a shaft seal.

69. The device of claim 68, wherein said shaft seal is an O-ring.

70. The device of claim 63, wherein said elongated stabilizer foot has an elongated perimeter adapted to contact the tissue.

71. A device for stabilizing tissue within a patient's body, said device comprising:

a base member; and

an elongated stabilizer foot extending outwardly from said base member in a first direction and fluidically connected with said base member, said foot having non-planar tissue-engaging features comprising a perimeter seal having a variable height around its perimeter, said foot being rotatable, in its entirety, relative to said base member, about an axis of rotation.

72. The device of claim 71, wherein said stabilizer foot further comprises a perforated screen recessed from the perimeter seal.

73. The device of claim 71, wherein said perimeter seal is retained within a groove in the stabilizer foot.

74. The device of claim 71, wherein said perimeter seal is higher at a front tip of said stabilizer foot as compared to a midpoint of said stabilizer foot.

75. The device of claim 71, wherein said perimeter seal is higher at a rear end of said stabilizer foot as compared to a midpoint of said stabilizer foot.

76. The device of claim 71, wherein said height varies to form a contoured shape adapted to remain sealed against a tissue surface.

77. A device for stabilizing tissue within a patient's body, said device comprising:

a base member; and

an elongated stabilizer foot extending outwardly from said base member in a first direction and fluidically connected with said base member, said foot having a non-planar tissue-engaging feature comprising a perimeter seal having a variable height around its perimeter, said foot being rotatable, in its entirety, relative to said base member, about an axis of rotation;

wherein said perimeter seal is a flexible seal having first and second legs disposed in an angular relationship.

78. The device of claim 77, wherein said perimeter seal comprises a plurality of legs angularly disposed in a bellows arrangement.

79. The device of claim 77, wherein said perimeter seal is made from an elastomeric material selected from the group consisting of: silicone, urethane rubber, neoprene, nitrile rubber, hytrel, and kraton.