

(19) World Intellectual Property Organization
International Bureau



(43) International Publication Date
24 December 2003 (24.12.2003)

PCT

(10) International Publication Number
WO 03/107423 A1

(51) International Patent Classification⁷: **H01L 25/075**,
23/495

(21) International Application Number: PCT/AU03/00724

(22) International Filing Date: 11 June 2003 (11.06.2003)

(25) Filing Language: English

(26) Publication Language: English

(30) Priority Data:
PS 2979 14 June 2002 (14.06.2002) AU
2002950814 14 August 2002 (14.08.2002) AU
2003901114 12 March 2003 (12.03.2003) AU

(71) Applicant (for all designated States except US): **LED-NIUM PTY. LTD.** [AU/AU]; Suite 3, Level 7, Chatswood Central, North Tower, 1-5 Railway Street, CHATSWOOD, New South Wales 2067 (AU).

(72) Inventors; and

(75) Inventors/Applicants (for US only): **JEGANATHAN,**

Balu [AU/AU]; 28 Manhattan Terrace, ROWVILLE, Victoria 3178 (AU). **MONTAGNAT, John, Albert** [AU/AU]; 59 Old Lilydale Road, EAST RINGWOOD, Victoria 3135 (AU).

(74) Agent: **BROWNE, Sylvan, Sherwood**; Davies Collison Cave, 1 Little Collins Street, MELBOURNE, Victoria 3000 (AU).

(81) Designated States (national): AE, AG, AL, AM, AT, AU, AZ, BA, BB, BG, BR, BY, BZ, CA, CH, CN, CO, CR, CU, CZ, DE, DK, DM, DZ, EC, EE, ES, FI, GB, GD, GE, GH, GM, HR, HU, ID, IL, IN, IS, JP, KE, KG, KP, KR, KZ, LC, LK, LR, LS, LT, LU, LV, MA, MD, MG, MK, MN, MW, MX, MZ, NI, NO, NZ, OM, PH, PL, PT, RO, RU, SC, SD, SE, SG, SK, SL, TJ, TM, TN, TR, TT, TZ, UA, UG, US, UZ, VC, VN, YU, ZA, ZM, ZW.

(84) Designated States (regional): ARIPO patent (GH, GM, KE, LS, MW, MZ, SD, SL, SZ, TZ, UG, ZM, ZW), Eurasian patent (AM, AZ, BY, KG, KZ, MD, RU, TJ, TM),

[Continued on next page]

(54) Title: A LAMP AND METHOD OF PRODUCING A LAMP

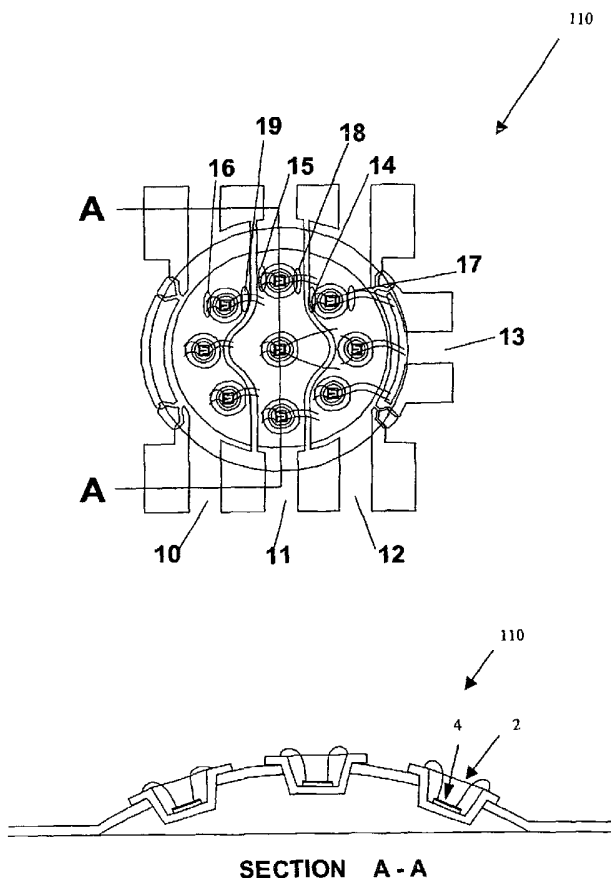

(57) Abstract: A method of producing a lamp, including: mounting light emitting junctions (LED's 4) in respective receptacles (2); mounting the receptacles on a curved support structure (110) so as to form a three-dimensional array; and placing the light emitting junctions in electrical connection with the support structure. The receptacles (2) are formed by pressing or stamping from thin sheet metal separately to support (110), and the LED's (4) are mounted therein prior to mounting the receptacles on the support (110). The receptacles can function to guide or reflect light output from the junctions. The support (110) can be a leadframe with cavities or holes to receive the receptacles (2).



WO 03/107423 A1



European patent (AT, BE, BG, CH, CY, CZ, DE, DK, EE, ES, FI, FR, GB, GR, HU, IE, IT, LU, MC, NL, PT, RO, SE, SI, SK, TR), OAPI patent (BF, BJ, CF, CG, CI, CM, GA, GN, GQ, GW, ML, MR, NE, SN, TD, TG).

For two-letter codes and other abbreviations, refer to the "Guidance Notes on Codes and Abbreviations" appearing at the beginning of each regular issue of the PCT Gazette.

Published:

— *with international search report*

A LAMP AND A METHOD OF PRODUCING A LAMP

Field of the invention

The present invention relates to a method of manufacturing a lamp using pre-packaged light emitting semiconductors which are inserted into a lead frame and to a
5 lamp produced thereby.

The present invention is an improvement on the subject matter of International Patent Publication No. WO 02/103794, the entire disclosure and subject matter of which is incorporated herein by reference.

Background of the Invention

10 Lighting applications involving the use of light emitting diodes (LEDs) are many and varied. Traditionally, it has been common to use a single LED as a small and discrete indicator, for example to indicate a status condition on a control panel for electrical plant.

It has also been known to provide a number of LEDs arranged in a two dimensional
15 array so as to provide greater light capabilities than would be provided by a single LED. However, not all of these arrangements are suitable for providing quality domestic or industrial lighting.

It is an object of the invention to provide a lamp, and method of producing a lamp, which is an improvement over the prior art or which at least provides a useful
20 alternative thereto.

Summary

The present invention provides a method of producing a lamp, including:
mounting light emitting junctions in respective receptacles;

- 2 -

mounting the receptacles on a curved support structure so as to form a three-dimensional array; and

placing the light emitting junctions in electrical connection with the support structure.

5

The present invention further provides a lamp including:

a curved electrically conductive support structure;

a plurality of receptacles mounted on the support structure so as to form a three-dimensional array; and

10 a plurality of light emitting junctions disposed in respective receptacles and electrically connected to the support structure.

The present invention further provides a lead frame for receiving a plurality of light emitting junctions to form a lamp, including:

15 a curved, electrically conductive support structure;

a plurality of cavities in said support structure for receiving a respective plurality of receptacles having light emitting junctions disposed therein, such that said light emitting junctions form a three-dimensional array.

In accordance with a preferred embodiment of the present invention, there is provided
20 a method of producing a three dimensional array of light emitting junctions on a supporting structure. This method provides a considerable simplification of the manufacturing process disclosed in prior art, and suggests itself potentially as the likely successor to methods of mounting light emitting junctions, that are in use today.

Preferably the method provides that light emitting junctions are attached into a one-
25 dimensional or two-dimensional array of preformed metallic, or other material, electrically conductive cups or other receptacles.

- 3 -

Preferably the cups in the linear array, with light emitting junctions attached, are subsequently singularised.

5 Preferably the singular cups are unsymmetrical in configuration to allow correct orientation, with respect to electrical polarity, of the light emitting junction within each cup and the orientation of each cup within the three dimensional array.

Preferably the singular cups are placed in a series of mating holes to a pre-determined pattern, within a curved portion of a lead frame with a part spherical surface.

10 Preferably the profile of the cups is designed to produce a specific pattern of light from each light emitting junction, such that the combined light pattern from a three dimensional array of cups on a lead frame is predictable and repeatable in mass production.

15 Preferably the array of cups so placed in the lead frame are restrained in their respective holes by welding, soldering, glueing or by other means which ensures the continuity of mechanical, thermal and electrical properties between the lead frame and the cups.

Preferably the cups are installed on electrical conductors within the lead frame which are used to control the flow of electric current and consequently the luminous output of the light emitting junctions.

20 Preferably the light emitting junctions are electrically connected to two conductors within the lead frame by means of intermediate conductors. The arrangement of connections of the intermediate conductors may be configured to allow the light emitting junctions to be controlled individually or in groups.

25 In another embodiment the cups in the array, each fitted with a light emitting junction, are singularised from the array and packaged on tape and reel, or other commonly

- 4 -

used packaging system. Such packaging provides scope for applications, other than a three dimensional array on a lead frame, where modular mounting of light emitting junctions is desirable.

In another aspect, there is provided a lamp, formed in accordance with the above-
5 described method.

In yet another aspect, there is provided a cup for receiving a light emitting junction, with side walls arranged to direct light which is output from the junction, the cup further serving to dissipate heat generated from the junction, which is thermally coupled thereto.

10 Brief Description of the Drawings

The invention is described, by way of non-limiting example only, with reference to the accompanying drawings, in which:

Figures 1A, 1B and C show plan, cross-sectional side and perspective views of a linear array of cups;

15 Figure 2A is a cross-sectional side view of a lead frame of convex form illustrating cup insertion;

Figure 2B is a cross-sectional side view of a lead frame of concave form illustrating cup insertion;

Figures 3A and 3B are plan and side cross-sectional views of a lead frame fitted with
20 cups and intermediate conductors;

Figure 4A and 4B are plane and side cross-sectional views of an example of a cup assembly with a light emitting junction mounted therein;

- 5 -

Figure 5 is a schematic diagram illustrating electrical connections of a lamp of one embodiment of the invention;

Figure 6 is a process flow diagram of a method of producing a lamp according to an embodiment of the invention;

5 Figures 7 to 14 illustrate steps in the process of Figure 6;

Figure 15 illustrates an alternative form of lamp lead frame (prior to singulation) according to a further embodiment of the invention;

Figure 16 illustrates a part of a lamp production process according to one embodiment; and

10 Figure 17 is a plan view of a lamp according to a further embodiment.

Detailed Description

Like reference indicators are used to indicate like or similar features in the drawings.

Referring initially to Figures 3A and 3B, preferred embodiments of the invention relate to a lamp and a method of producing a lamp having a plurality of light emitting
15 junctions 4 mounted on a lead frame 110 having curved conductors 10, 11 and 12. The junctions 4 are located in respective receptacles 2 which are mounted onto the lead frame 110 and subsequently electrical connections are formed between the junctions 4 and the curved conductors, 10, 11, 12 and 13 (being the supply
20 conductor) to enable an electrical circuit to be completed via each of the junctions 4 when the lamp is turned on. Conductors 10, 11 and 12 are three-dimensionally curved (for example, spherically) but supply conductor 13 is only two-dimensionally curved (i.e. planar but curved).

The receptacles 2 are formed separately to lead frame 110 and the junctions 4 are mounted therein prior to the receptacles 2 being mounted on the lead frame 110. The

- 6 -

receptacles 2 are preferably formed in bulk from a strip or sheet material and then separated from that material either before or after the junctions 4 are mounted in the receptacles 2.

A linear array 1 of receptacles 2 (formed preferably as generally concave cups), as shown in Figures 1A, 1B and 1C, is preferably formed from thin sheet metal, copper or the like, by conventional means, such as pressing or stamping. Other forms of receptacles may be appropriate but all such receptacles are referred to herein as cups for the sake of simplicity. A cup 2 having a junction 4 disposed or affixed therein is referred to herein as a cup assembly 3, for convenience. Instead of a linear (one-dimensional) array, the cups may be formed in a two-dimensional sheet array.

One advantageous aspect of the preferred cup is its shape, which allows each cup to function as an optical guide for controlling the direction of light output from the junction mounted therein. Each cup 2 is preferably of a generally circular form when seen in plan view, as shown in Figure 1A, although other forms, such as elliptical or more rectangular forms, may function suitably. The preferred cup form has a circular inner base of radius r , from which cup walls of a generally frustoconical shape diverge at an angle X (relative to horizontals as shown in Figure 1B) toward a lip of the cup, having outer radius R . The vertical depth from the lip of the cup to the inner circular base surface of the cup is shown by reference T in Figure 1B.

As shown in Figure 2A, the cup assemblies 3 are mounted in the lead frame so that their angular orientation is displaced with respect to one another (based on the lead frame 80 having a part spherical shape in the area where the cups 2 are mounted thereon). This angular displacement is designated by reference Z in Figure 2.

The shape of the cups 2, and dimensions of radii R and r , side (displacement) angle Z and depth T , are preferably determined by their respective influence on the light pattern which emerges from the cup. It is preferred that the luminous intensity emanating from the lamp be optimised for linearity within the overall angle of

- 7 -

incidence, 2 times angle Y (shown in Figure 2A), of the beam from the lamp. The solid angle subtended by the beam, $2 \times Y$ is traditionally referred to as the 'half angle'. It is defined as 'the angle within which the luminous intensity exceeds 50% of the maximum value of the beam'. This is a significant factor in the optical performance of the lamp because it affects the effectiveness of the illumination provided by a lamp of this nature.

The influence of these factors, R, r, T and angle X, together with the radius of curvature C of the lead frame, and the displacement angle Z, of each cup within the part spherical portion of the lead frame, constitute the parameters which determine the value of angle Y and therefore the nature of the output illumination pattern of the assembled lamp.

These factors are variables in each lamp design and a variety of lamps can be designed by optimising these variables with respect to the preferred half angle, the number of cups installed in the lamp, and the relative positions of the cups. For further lamp design examples, please refer to Figures 15 and 17.

After formation, the array of cups is preferably plated selectively, with silver, silver alloy or similar material. The plating is to enhance the optical performance of each cup by providing a highly reflective surface, and in addition may simplify the attachment process (eg. soldering or applying silver adhesive) employed to restrain the cups 2 in holes 6 (shown in Figure 2A) in the lead frame.

Subsequent to formation and plating of the linear array of cups, a light emitting junction (die) 4 is attached to the bottom inner surface of each cup to form a cup assembly 3. (Throughout the specification, reference to a "die" is used interchangeably with "junction" and "LED".) Due precautions are required to align each die consistently with the linear array. The cups are preferably singularised from the array, by conventional means, and the polarity indicated by notching, stamping (or some other method) a mark 7 on one side of the cup 2. In one preferred form, the

- 8 -

mark 7 is a truncation or flattening of one outer edge of the cup. The formation of the mark 7 on the cups may be performed immediately after the cups are formed and before plating so as to assist in aligning the junctions consistently with respect to polarity.

5 In an alternative form of lead frame to the convex domed shape shown in Figure 2A, a concave form of the lead frame may be formed, such as that shown in Figure 2B. Apart from the differences in orientation of curvature of the lead frame supporting structure, the concave lamp embodiment shown in Figure 2B may be formed in a similar manner to that of Figure 2A and other convex lamp embodiments shown in the
10 drawings and described herein. In particular, the lamp production process as shown and described in relation to Figure 6 is applicable to concave lead frame arrangements. For example, instead of forming a dome in the central portion of the lead frame at step 640, a bowl (inverted dome) may be formed. Such a concave form of the lead frame would involve more of a focussing of the light emitted from the
15 junctions and thus such an embodiment would be more suitable for applications requiring a more focussed, rather than even, distribution of light. This lamp embodiment would thus have a focal length approximately equal to the radius of curvature C of the central curved portion of the lead frame. The effectiveness of the focus in this case will be partly determined by the magnitude of the radius of
20 curvature C and will be influenced by the values of R r and T.

A lamp is formed by inserting singular cups, complete with dies, into holes 6 in the curved lead frame conductors 10,11,12 of the lead frame 110, as shown in Figure 3A. In the shown embodiment, pairs of intermediate conductors 14,15,16 are attached by wire bonding between the active portion of the dies of a first polarity and conductors
25 10,11,12. In addition, pairs of intermediate conductors 17,18,19 are attached by wire bonding to the active portion of the dies of a second polarity and to a common supply conductor 13 and conductors 11 and 12, respectively. This configuration allows

- 9 -

control of the current, and therefore control of the intensity of the emitted light, flowing through the groups of light emitting junctions mounted on conductors 10,11,12.

Apart from common supply conductor 13, only three curved lead frame conductors, 5 10, 11 and 12 are shown in Figure 3A. It is specifically envisioned that a greater number of curved lead frame conductors may be employed, each supporting a number of cup assemblies. For example, while Figure 15 shows an embodiment of the lead frame for supporting 18 junctions within respective cup assemblies distributed on three separate conductors 113, 114 and 115, this arrangement may be 10 modified to provide five separate conductors supporting six cup assemblies in each. Further embodiments are contemplated, although not shown, in which a larger number of cup assemblies may be supported, for example in the order of 50 to 100.

Although the intermediate conductors 17, 18 and 19 shown in Figure 3A are 15 described as being in pairs, it may be appropriate to use single intermediate conductors instead, for example where small, low current junctions are employed in the cup assemblies 3.

The embodiment shown in Figures 3A and 3B is particularly suitable for large 20 junctions which draw greater currents than smaller junctions and thus pairs of intermediate conductors are desirable for allowing for even collection and supply of current to the active regions of the die. The pairs of conductors also provide a second current path which serves to reduce possible losses associated with having only one intermediate conducting wire to and from the die.

25

In an alternative embodiment to that shown in Figures 3A and 3B, the pairs of intermediate conductors 14, 15 and 16 may be connected to the cup instead of to curved conductors 10, 11 and 12. In this alternative embodiment, each of the cups is in electrical connection with the curved conductors 10, 11 and 12 by virtue of being

- 10 -

mounted thereon using a conductive material, such as solder or a silver glue. This alternative arrangement allows for the pairs of intermediate conductors 14, 15 and 16 to be attached to an interior wall of the cup 2 prior to mounting of the cup in the holes 6 of the curved conductors 10, 11 and 12. In other respects, this embodiment is similar to that shown and described above in relation to Figures 3A and 3B.

In a further alternative embodiment (described further below in relation to Figures 4A and 4B), instead of the intermediate conductors 14, 15 and 16 being connected to the interior wall of the cups, pairs of conductors 26 and 27 are connected between the cathode and anode of the die 4 and conductive regions 22 and 23, respectively. Further intermediate conductors are then used to connect between the curved conductors 10, 11 and 12 and the conductive regions 22 and 23.

In another embodiment (shown in Figure 17), the current flowing through each individual light emitting junction can be controlled independently of all others by suitably arranging the connection of intermediate conductors. Figure 17 shows a possible arrangement of 8 LEDs which can be individually and independently controlled. In this arrangement, the central curved (spherical) part of the lead frame is not partitioned into separate conductors, but is instead a common conductor 114 for all LEDs mounted on it. It is convenient for consistency to make this common conductor 114 the cathode (or negative terminal). There are eight anodes 132 shown, one for each die, through which the flow of current to each die can be controlled. The anodes 132 are arranged in the form of spokes about the central part of the lamp lead frame. It is convenient to make the cathode common because AlGaInP dies (Red and Amber) have the cathode on the underside of the die (which is electrically and physically connected to the cup), so when mounted on a conductor it must be the cathode for these dies, and since InGaN dies (Green and Blue) have an insulated underside it is convenient to standardize the connections with respect to polarity. This is the opposite polarity to the lead frames which have three groups of LEDs. Common is positive for these because the undersides of the chips (negative)

- 11 -

may be electrically connected to respective ones of the three curved sections of the lead frame via the conductive cups in which they are disposed.

The light emitted by the LEDs is of a narrow frequency or wavelength bandwidth, which in the visible spectrum is perceived as a specific colour. LED's with red, yellow, green and blue light have become commonplace. If LEDs of different colours are arranged in a cluster such as that shown in Figure 17, it becomes possible to generate light from LEDs which is perceived to be of a different colour to the characteristic colour of any of the constituent LEDs in the array. By controlling the excitation current in each LED, the level of light output may be controlled, which allows the light from the LEDs to be combined in variable proportions thereby generating different colours.

For example, red, green and blue lights can be combined in the correct proportions to give a generally white light appearance. Similarly, the lamp can be arranged to emit light of a single colour by passing current through only those LEDs which have the same wavelength, and to change colour by reducing the excitation to those LEDs of a first wavelength and simultaneously increasing the excitation to a group of LEDs of a second wavelength. A suitable control system can be devised to generate any combination of colour and intensity within the possibilities presented by the characteristics of the LED dies installed in the lamp.

Packaging the lamp in selected optically suitable material, such as epoxy resin, can further enhance the process of combining, or otherwise, the light emitted by the LED dies. If, for example, an epoxy or other encapsulating material is chosen which has low light absorption, minimum back scatter and superior diffusion properties then it may be possible to achieve an almost homogeneous single colour emission from the lamp and to vary the colour widely over the visible spectrum. This may be achieved even though some of the LEDs may be mounted near the extremities of the spherical

- 12 -

part of the lamp and have generally divergent beams of light. In another arrangement, a package of optically clear low absorption material may be chosen for a function where combination of light into a single colour is of less importance.

- 5 The electronics industry has devised many ways of controlling LED arrays and displays. These are generally suitable for small power LEDs – in the order of 100 milliwatts of power per LED, where the current to be controlled is in the order of 20 – 50 milliamps.
- 10 LED dies with an area of one square millimeter (die size 1mm x 1mm) require excitation current to be up to 350 – 500milliamps. Developments in the industry are expected to deliver LED dies of 2.5 square millimeters and larger, which will require excitation currents in excess of 1000 milliamps. In general, LED controllers will be required to have a power handling capacity of 5 Watts per LED, compared to the
- 15 present range at around 100 milliwatts per LED – an increase of 50 times.

The present invention encompasses, but is not restricted to, LED die sizes up to 1.26 x 1.26mm which each consume 1 Watt of power. The control circuit driving such a lamp must be capable of controlling a number of such LEDs. For example, if 18

20 LEDs are mounted in the lamp, the control circuit will need to be able to drive an output in the order of 18 Watts.

In another preferred embodiment, illustrated by Figures 4A and 4B, alternative cups 32 are provided with a layer of electrical insulation 20, on an upper surface of cup flange 21, with areas of electrically conductive material 22 & 23 superimposed on the

25 insulation. This allows the active areas of the die 24 & 25, to be connected by bonding wires 26 & 27, to the conductive areas 22 & 23. These connections can be made during the process of attaching the dies to the cups. It presents a considerable simplification to the process of wire bonding described above, in which the bonding equipment is required to accommodate the layout of a three dimensional array.

- 13 -

Simple conventional practices can be used to make the equivalent to intermediate connections 14 & 17 shown in Figure 3A, if the bonding wires are attached to the cups when they are in a linear array. This embodiment further allows the use of packaged light emitting junctions in many other applications. Commonly used 'pick and place' machinery can be used to automatically install the cups and to make the connections.

Conductive regions 22 and 23 are preferably formed in a thin layer over a layer of insulation applied to the rim of each cup. The insulating material may be epoxy or some other compound which has good adhesion to the surface of the cup and gives a good electrical insulation in thin layer form. The conductive regions may be formed by metal deposition or other suitable process. Such processes are used to produce printed circuits, in particular metal cored printed circuits which are often manufactured on a metallic substrate of aluminium.

A cup assembly 3 or package (i.e. a cup with a junction mounted on it) has significant advantages over light emitting junctions available in other surface mounting packages. The limitation imposed by poor heat dissipation from conventional packages is largely overcome. A cup package can be easily installed directly into a prepared recess in a 'Metal Cored Printed Circuit Board' (MCPCB), thus having applications other than in lamp lighting. An almost ideal thermal path may thus be created, from the heat source (the die) through the cup material and directly into the highly dissipative core of an MCPCB.

Restrictions on the size of a die and the practical limit of power that a die can dissipate control the quantity of light currently available from these devices. By providing a method of effectively and conveniently dissipating heat losses in a die, practical restrictions on the size of dies which can be employed successfully are effectively removed. Thus, cups designed to accommodate dies which can consume several watts of power, and which produce light somewhat in proportion to the input power, can be produced simply and cheaply.

- 14 -

Examples of large LED dies which can be used in embodiments of the invention are listed on Table 1 below. For smaller LED dies, there are numerous varieties on the market and suitable dies would be apparent to skilled persons.

5

TABLE 1

<u>Colour</u>	<u>Wavelength</u>	<u>Forward Voltage</u>	<u>Part No</u>	<u>Manufacturer</u>
Blue	470nm	3.6 - 4.0 V	LE470-P2-G	AXT
Green	525nm	3.6 - 4.0	LE525-P2-G	AXT
Amber	590nm	2.0 - 2.4	ES-CAYL529	Epistar
Red	625nm	2.0 - 2.4	ES-CAHR529	Epistar

10 Referring now to Figure 6, a process flow diagram is shown, by which a lamp can be produced according to embodiments of the invention. The preferred lamp production process involves forming the cups separately, having junctions mounted therein, and mounting the cup assemblies onto the lead frame once the lead frame has been manufactured to a certain point (i.e. past step 640). Once the cups are attached to
15 the lead frame, they are processed together to form the lamp at step 665.

At step 605, the cups are formed, for example by a pressing tool, from a copper plate or other suitable sheet or strip of deformable conductive material, and each of the cups is pressed from the plate or sheet so as to form the receptacles illustrated in
20 Figures 1A to 1C. Step 605 includes forming the mark 7 on each cup. Once singulated from the material from which they were pressed, the cups are plated at step 610 with a silver, aluminium or other conductive material, for example by barrel plating, precision plating or vapor deposition, to achieve a plating thickness of about 4 to 8 microns. After plating, the dies (referred to as chips in Figure 6) are attached to

- 15 -

the inside base surface of the cup at step 615, preferably by a silver glue so that the junction faces outward away from the base surface. Once the junctions are attached at step 615 to the cups, the thus-formed cup assemblies may be packaged into a linear strip or a two-dimensional sheet which can be fed into a robotic pick and place
5 machine, for example, such as those used in surface mount technology.

Independently of cup formation, lead frame processing begins at step 620 by machining the basic shape of the lead frame. The machining may be by etching or mechanical stamping and it is preferred that the lead frame be formed of copper or
10 copper alloy sheet material in the order of about 400 microns thickness. The thickness of the lead frame material is preferably chosen for optimum thermal conduction of excess heat away from the cup assemblies. For example, if larger dies are installed in the cup assemblies there will be more heat generated than if smaller dies are used. Increasing the thickness of the lead frame will assist in conducting this
15 heat away from the lamp. The basic shape of the lead frame formed at step 620 includes conductors 10, 11, 12 and 13 within a surrounding supporting frame of copper sheet material prior to being spherically deformed and separated into separate conductors. At step 625, a center conductive portion (which becomes conductors 10,
20 11, 12 and 13) of each lead frame is plated, preferably with silver or aluminium, to a thickness of about 4 to 8 microns. The plating is applied at least over the central portion of the lead frame which will receive the cups and be in electrical contact therewith, but may be applied over the whole upper surface of the lead frame for economy or convenience. Once the plating has been completed, holes are punched
25 into the central (plated) portion of the lead frame, at step 630. These holes will form the holes 6 shown in Figure 2 for receiving the cups after the spherical shape has been applied to the central portion of the lead frame. Next, at step 635, the conductors 10, 11 and 12 are partitioned (conductor 13 is preferably already partitioned as part of step 620) so as to separate groups of holes from each other in the central portion of the lead frame. This partitioning is preferably performed using a

- 16 -

smooth and precise cutting tool so that no additional processing is required to finish the edges created between the conductors during partitioning.

The partitioning is performed according to the desired grouping of the holes in the central conductive portion of the lead frame. Accordingly, this grouping will depend
5 on the number of holes formed in that portion during step 630. In a preferred embodiment, nine holes are formed at step 630. In alternative embodiments, for example such as that shown in Figure 15, a different number of holes may be formed in the lead frame for receiving cups with junctions therein. The alternative
10 embodiment shown in Figure 15 has eighteen holes 120 formed in the central portion of the lead frame 110, with those holes grouped into three separate groups of six on conductors 113, 114 and 115. The partitioning step 635 must also take account of the deformation of the material of the lead frame during the subsequent dome forming step 640. For example, the holes formed in conductor 11 have a tendency to deform
15 (elongate to become somewhat elliptical) slightly along with the deformation of the plated lead frame material during the spherical dome forming. Accordingly, the hole forming and partitioning steps 630 and 635 may be performed so as to compensate for deformation of the material during dome forming, for example by forming the holes on conductor 11 in a flattened elliptical form so that they stretch out to a more circular
20 form during the dome forming step.

It is preferred that the dome forming step 640 be performed by some kind of press tool so as to provide a generally part-spherical shape to the central portion of the lead frame.

25

At step 645, cup assemblies 3 formed through steps 605 to 615 are attached to the lead frame following the dome forming step 640. This attachment is preferably performed by soldering, welding or using a conductive adhesive once the cup assemblies are placed in the holes 6 by, for example, precision robotic machinery.

- 17 -

After the cup assemblies are placed into the holes and fixed thereto, wire bonding is performed at step 650 so as to electrically connect the junctions in the cups to the conductors 10, 11, 12 and 13, as previously described. For this wire bonding, gold wire is preferably employed using known heat/sonic welding techniques, the wire
5 having a diameter in the order of 25 to 50 microns. Other forms of bonding techniques using different wire material and wire diameters are common in the industry, and may alternatively be employed.

After the wire bonding, a phosphor is optionally applied over the top of individual
10 junctions at step 655. This is done by evenly mixing a phosphor powder into an epoxy and dispensing the epoxy in drops onto the top light emitting surface of each junction. At step 660, an optically clear epoxy resin or thermoplastic is applied to the central part of the lead frame so as to encase it. If no phosphor was deposited over the individual junctions at step 655, a phosphor powder may be mixed in with the
15 epoxy encasing the central part of the lead frame at step 660. In order to apply the epoxy or thermoplastic, the lead frame is inverted and placed into a mould of a complementary part-spherical shape. Once the epoxy resin or thermoplastic has cured or otherwise set, the lead frames are then processed, at step 665, so as to
20 singulate them from each other, including punching the conductors 10, 11, 12 and 13 free of those parts of the lead frame which held them in place prior to the epoxy application. It is also at this step that webs (evident from the drawings) connecting the conductors 10, 11 and 12 are removed, for example by punching, thus electrically isolating those conductors from each other.

25 Figures 7 to 14 illustrate the above described process steps and, in conjunction with Table 2 below, serve to illustrate a production process in accordance with a preferred embodiment. Table 2 below summarises some of the processing steps described above and preferred methods and materials for these steps.

TABLE 2

<u>Item</u>	<u>Process</u>	<u>Method</u>	<u>Material</u> Generic	<u>Material</u> e.g.
Lead Frame	Machine Basic Shape	a) Etching, or b) Mechanical stamping	Copper Strip	Copper Alloy A194 HH Nominal Thickness 15mil.(381 Microns)
	Plating	a) Barrel Plating b) Precision Plating c) Vapour Deposition	Silver or Aluminium	4 to 8 Microns
	Cup hole formation	Press Tool	----	
	Partitioning	Press Tool	----	
	Dome formation	Press Tool	----	
	Cups	Machine Basic Shape	Press Tool	----
Plating		Barrel plating Precision Plating Vapour Deposition	Silver or Aluminium	4 to 8 Microns
Cup Attachment		Soldering, or Conductive Glueing	Lead/tin alloy or paste Silver glue	70/30 Lead /Tin CMI 121-03

- 19 -

Chip Insertion	Apply adhesive	Dispenser	Silver Glue	CMI 121-03
	Chip Placement	Robotic	LED chip	InGaN, AlInGaP
	Heat Treatment	Process oven	----	
Wire Bonding	Electrical connections	Heat/Sonic Welder	Gold Wire	25 - 50 Microns Diam.
<i>Optional</i>	Apply Phosphor	Dispenser	Phosphor Powder	Hung Ta 80911 465 ~ 470nm, or 11001 471 ~ 474nm
			Optically Clear Epoxy	Epifine T-6000A2 & T-6000B
Packaging	Moulded Epoxy, or	Mould, Process Oven	Optically Clear	Epifine T-6000A2
			Epoxy Resin & catalyst	T-6000B
	Compression Moulding	Moulding Machine	Optically Clear	Degussa Plexiglas df21 8N
			Thermoplastic	
Finish	Singulation	Press Tool	----	

Figure 15 shows an alternative form of lead frame 110 having a higher number of holes 120 disposed in the central portion thereof. Conductors 113, 114 and 115 each support six cup assemblies and are arranged so as to generally provide an even distribution of light from the junctions when the lamp is in operation. The precise configuration and location of the groups of holes on conductors 113, 114 and 115 may be varied as required, in order to achieve a desired light output pattern. The

- 20 -

number and positioning of the holes 120 may also be varied, depending on practical manufacturing requirements.

Figure 16 illustrates a part of the lamp production process, generally corresponding to
5 step 645 of Figure 6, where the cup assemblies are placed into holes 6 or 120 in the
lead frame 110. The lead frames 110 are processed across a carrier 119 in
sequence so that the cup assemblies 3 may be placed in recesses 120 (holes 6).
The carrier 119 may be constructed to mate with the part spherical surface, and the
reference markers, of the lead frame. This mating part may be either a raised convex
10 face which is complimentary to the concave underside of the convex lead frame, or
alternatively be a concave recess which is complimentary to the convex underside of
the concave lead frame. Convex and concave lamp profiles such as those illustrated
by Figure 2A and Figure 2B may thus be constructed by utilising alternate profiles on
the carrier. The carrier 119 may be rotatable on a shaft 121, for pivotable movement
15 about an X axis, and a shaft 122, for pivotable movement about a Y axis. In this way,
the lead frame 110 can be positioned at a mounting station (not shown) and rotated
about the X or Y axis relative to the mounting station so as to facilitate placement of
the cup assemblies 3 in the recesses. Alternatively, if a suitable robotics mechanism
is available, the carrier 119 is fixed in place and the robotic placement machinery can
20 place the cup assemblies 3 into the respective recesses, accounting for the part-
spherical shape of the central portion of the lead frame. In such an embodiment,
reference markers are provided along the outer edges on the lead frame 110 for
positional calibration by the robotics machinery.

25 Certain modifications or enhancements to the embodiments herein before described
will be apparent to those skilled in the art without departing from the spirit and scope
of the present invention.

THE CLAIMS:

1. A method of producing a lamp, including:
mounting light emitting junctions in respective receptacles;
5 mounting the receptacles on a curved support structure so as to form a three-dimensional array; and
placing the light emitting junctions in electrical connection with the support structure.
2. A method as claimed in claim 1, wherein the support structure includes a
10 plurality of conductors and the method further includes forming at least one of the conductors in a curved configuration.
3. A method as claimed in claim 2, wherein at least some of the conductors are formed in a part spherical configuration.
4. A method as claimed in claim 3, wherein the at least some conductors are
15 formed in a convex configuration.
5. A method as claimed in claim 3, wherein the at least some conductors are formed in a concave configuration.
6. A method as claimed in claim 2, in which the light emitting junctions are connected to the at least one curved conductor by intermediate conductors.
- 20 7. A method as claimed in claim 6, wherein each of the plurality of conductors is curved, one of said curved conductors being two-dimensionally curved and the rest of said curved conductors being three-dimensionally curved.
8. A method as claimed in claim 7, wherein each junction is electrically connected to two of the curved conductors.

- 22 -

9. A method as claimed in claim 2, wherein the junctions are electrically connected to conductors such that the current flowing in groups of junctions can be controlled separately to the current flowing in other groups of junctions.

10. A method as claimed in claim 2, wherein the junctions are connected to
5 conductors such that the current flowing in any junction can be controlled independently of the current in every other junction.

11. A method as claimed in claim 1 or 2, wherein the receptacles are preformed cups.

12. A method as claimed in claim 11, wherein the cups function as optical guides
10 for controlling the direction of light output from respective junctions mounted therein.

13. A method as claimed in claim 11, wherein the cups are formed in a one-dimensional or two-dimensional array and are subsequently singularised.

14. A method as claimed in claim 11, wherein the cups are mounted in respective cavities in the support structure.

15 15. A method as claimed in claim 14, wherein the cavities are holes extending through the support structure.

16. A method as claimed in claim 11, wherein the junctions installed in the cups are electrically connected to conductive areas, insulated from, but mounted on, a flange of each cup.

20 17. A method as claimed in claim 13, wherein singularised cups, with light emitting junctions attached, are packaged in tape and reel, or other, bulk packaging.

18. A method as claimed in claim 1, wherein the support structure is formed as a lead frame.

- 23 -

19. A method as claimed in claim 18, wherein the support structure is formed by:
(a) stamping a conductive plate in a predetermined configuration;
(b) forming cavities in a central portion of the conductive plate for receiving
said receptacles; and
5 (c) impressing a curved configuration on said central portion.
20. A method as claimed in claim 19, wherein said central portion is separated into
separate conductors before the step of impressing.
21. A method as claimed in claim 19, wherein the central portion is coated with
silver or silver alloy.
- 10 22. A lamp formed in accordance with the method of any one of claims 1 to 21.
23. A lamp including:
a curved electrically conductive support structure;
a plurality of receptacles mounted on the support structure so as to form a
three-dimensional array; and
15 a plurality of light emitting junctions disposed in respective receptacles and
electrically connected to the support structure.
24. A lamp as claimed in claim 23, wherein each receptacle is a cup.
25. A lamp as claimed in claim 24, wherein each cup has side walls arranged to
direct light which is output from the junction, the cup further serving to dissipate heat
20 generated from the junction, which is thermally coupled thereto.
26. A lamp as claimed in claim 24, wherein each cup further includes an
electrically insulative layer, upon which is provided an electrically conductive area, to
allow for electrical connection between a bonding wire of the light emitting junction
mounted in the cup and an intermediate connection for coupling the junction to a
25 conductor, for establishing a current through the light emitting junction.

- 24 -

27. A lamp as claimed in claim 24, wherein each cup is formed with a polarity indicator toward one side thereof for indicating the polarity of the junction disposed therein.
28. A lamp as claimed in claim 23, wherein the support structure includes a plurality of conductors, at least one conductor being curved, and the receptacles are mounted on the at least one curved conductor so that the light emitting junctions adopt a three-dimensional array.
29. A lamp as claimed in claim 22 or 23, wherein one or more of the junctions is adapted to emit light of a different color to the other junctions.
30. A lamp as claimed in claim 28, wherein the light emitting junctions are connected to the at least one curved conductor by intermediate conductors.
31. A lamp as claimed in claim 30, wherein each of the plurality of conductors is curved, one of said curved conductors being two-dimensionally curved and the rest of said curved conductors being three-dimensionally curved.
32. A lamp as claimed in claim 31, wherein each junction is electrically connected to two of the curved conductors.
33. A lamp as claimed in claim 23, wherein the junctions are electrically connected to conductors such that the current flowing in groups of junctions can be controlled separately to the current flowing in other groups of junctions.
34. A lamp as claimed in claim 23, wherein the junctions are connected to conductors such that the current flowing in any junction can be controlled independently of the current in every other junction.
35. A lamp as claimed in claim 24, wherein the cups are mounted in respective cavities in the support structure.

- 25 -

36. A lamp as claimed in claim 35, wherein the cavities are holes extending through the support structure.
37. A lamp as claimed in claim 28, wherein at least some of the conductors are formed in a part spherical configuration.
- 5 38. A lamp as claimed in claim 37, wherein at least some of the conductors are formed in a convex configuration.
39. A lamp as claimed in claim 37, wherein at least some of the conductors are formed in a concave configuration.
40. A lamp as claimed in claim 23, wherein the support structure is formed as a
10 lead frame.
41. A lamp as claimed in claim 40, wherein the lead frame is formed of copper or copper alloy.
42. A lamp as claimed in claim 41, wherein at least a part of the lead frame is coated with silver or silver alloy.
- 15 43. A lamp as claimed in claim 23, wherein the receptacles are formed of copper or copper alloy.
44. A lamp as claimed in claim 43, wherein the receptacles are coated with silver
20 or silver alloy.
45. A lamp as claimed in claim 40, wherein the support structure is formed by:
- (a) stamping a conductive plate in a predetermined configuration;
 - (b) coating a central portion of the conductive plate with silver or silver alloy;
 - 25 (c) forming cavities in said central portion for receiving said receptacles; and
 - (d) impressing a curved configuration on said central portion.

- 26 -

46. A lamp as claimed in claim 45, wherein said central portion is separated into separate conductors before the step of impressing.

47. A lead frame for receiving a plurality of light emitting junctions to form a lamp,
5 including:

a curved, electrically conductive support structure;

a plurality of cavities in said support structure for receiving a respective plurality of receptacles having light emitting junctions disposed therein, such that said light emitting junctions form a three-dimensional array.

10

48. A lead frame as claimed in claim 47, wherein the support structure is formed by:

(a) stamping a conductive plate in a predetermined configuration;

(b) forming cavities in a central portion of the conductive plate for receiving
15 said receptacles; and

(c) impressing a curved configuration on said central portion.

49. A lead frame as claimed in claim 48, wherein said central portion is separated into separate conductors before the step of impressing.

50. A lead frame as claimed in claim 48, wherein the central portion is coated with
20 silver or silver alloy.

1/18

FIGURE 1A

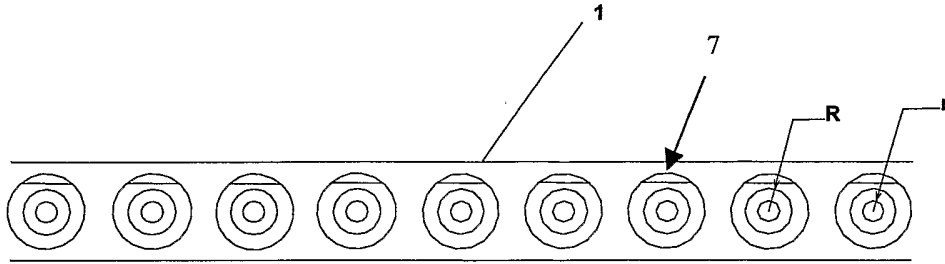

FIGURE 1B

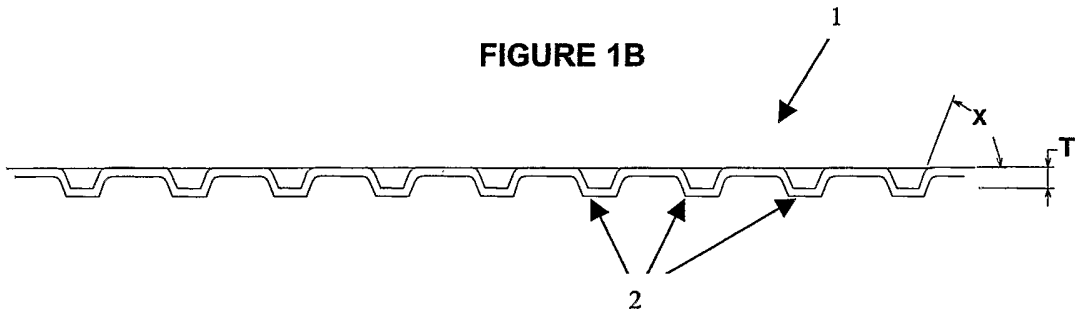
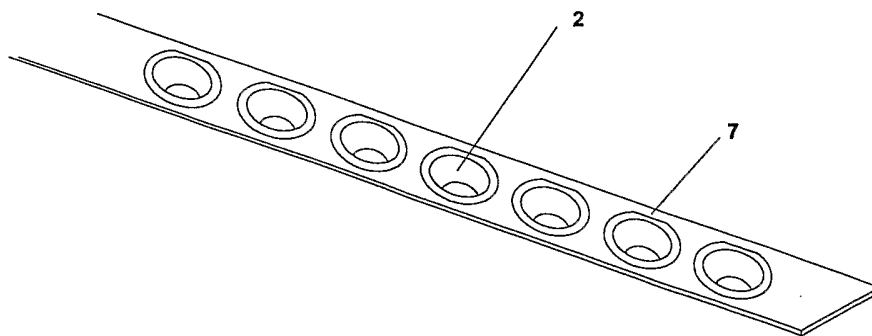

FIGURE 1C



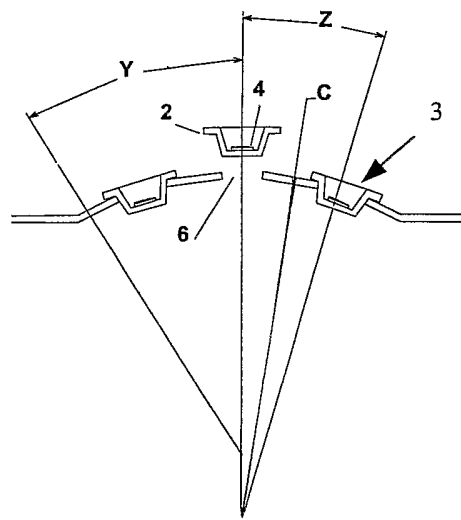

FIGURE 2A

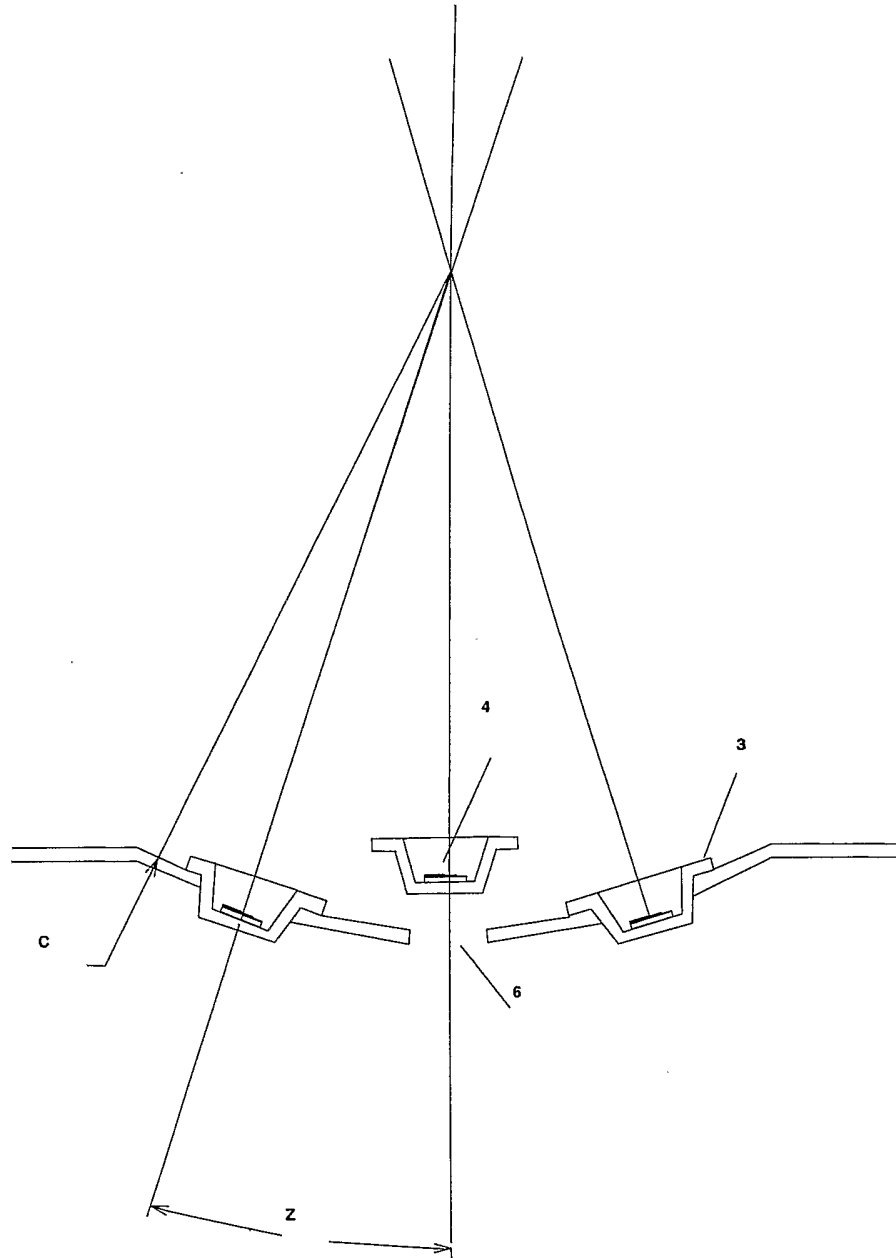

FIGURE 2B

Figure 3A

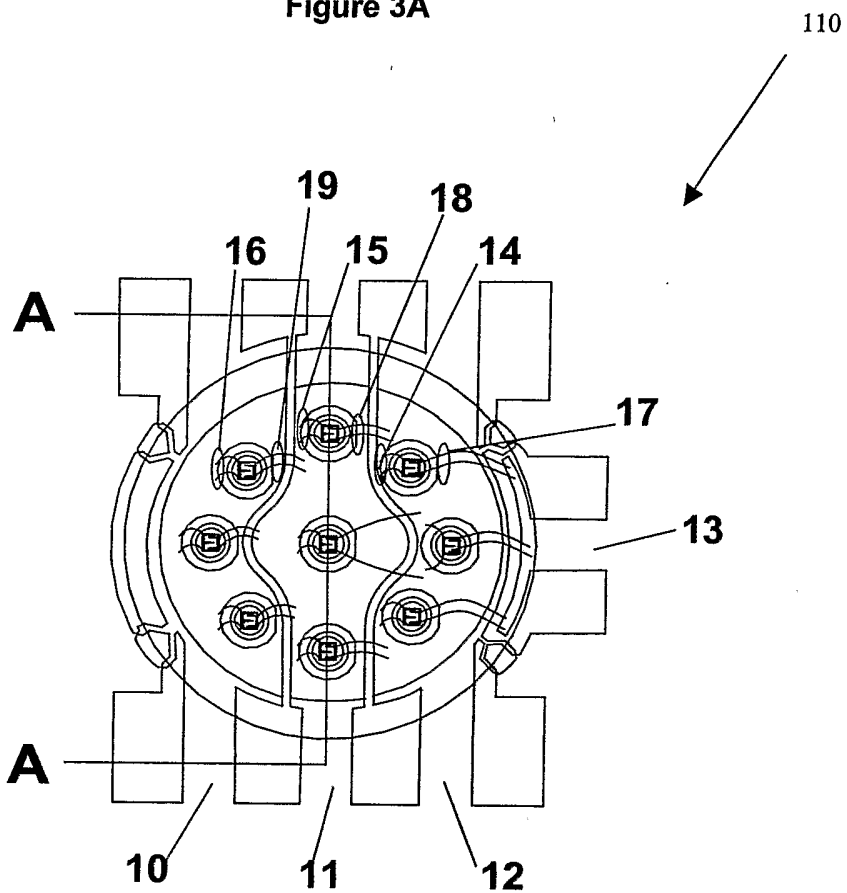
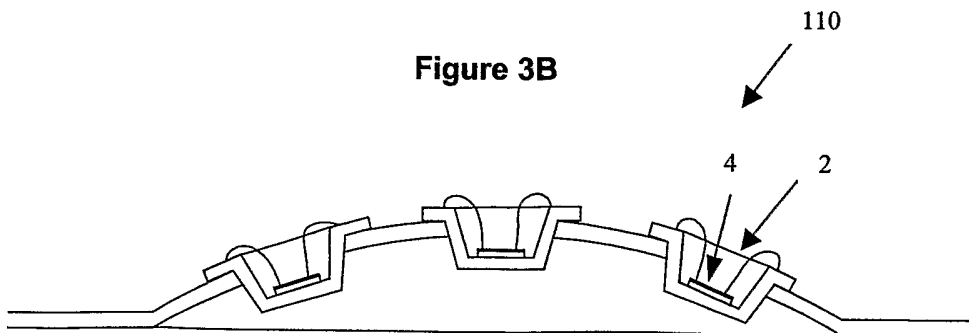

Figure 3B



SECTION A - A

FIGURE 4A

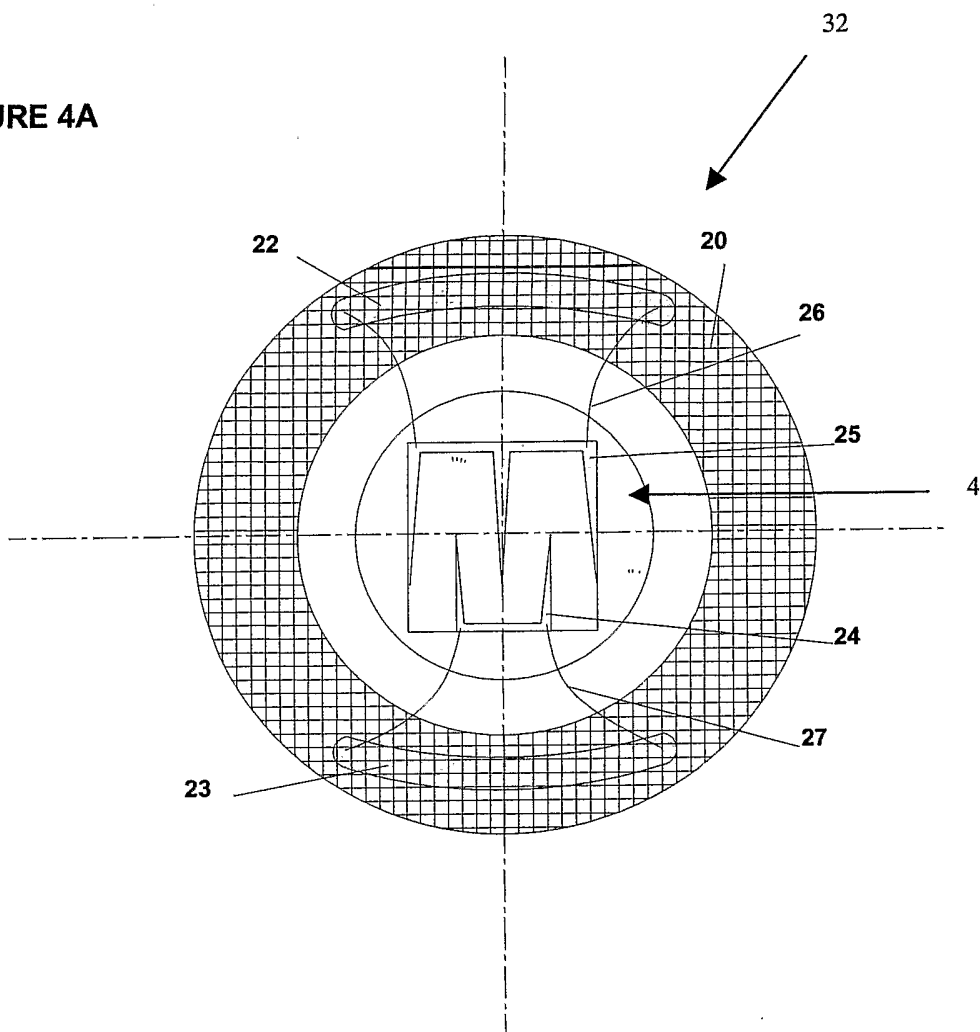
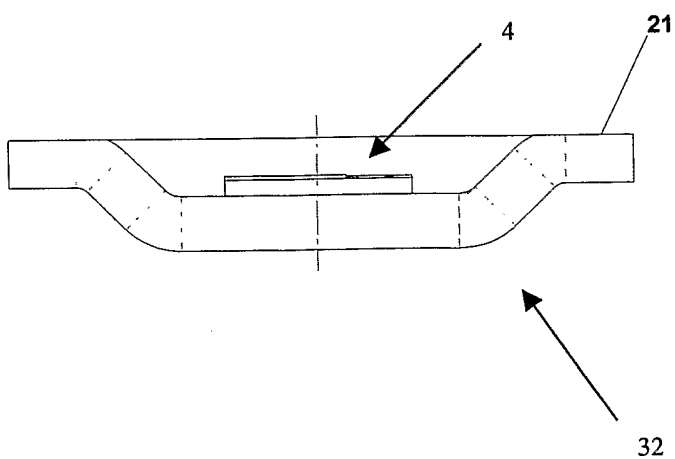

FIGURE 4B



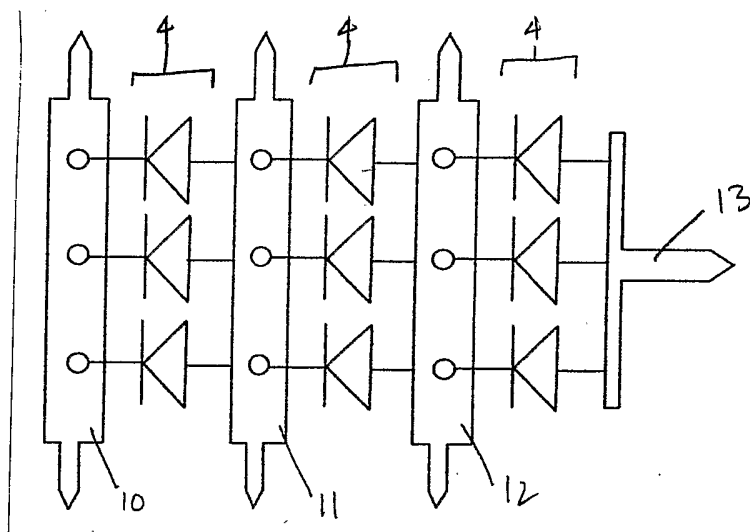

FIGURE 5

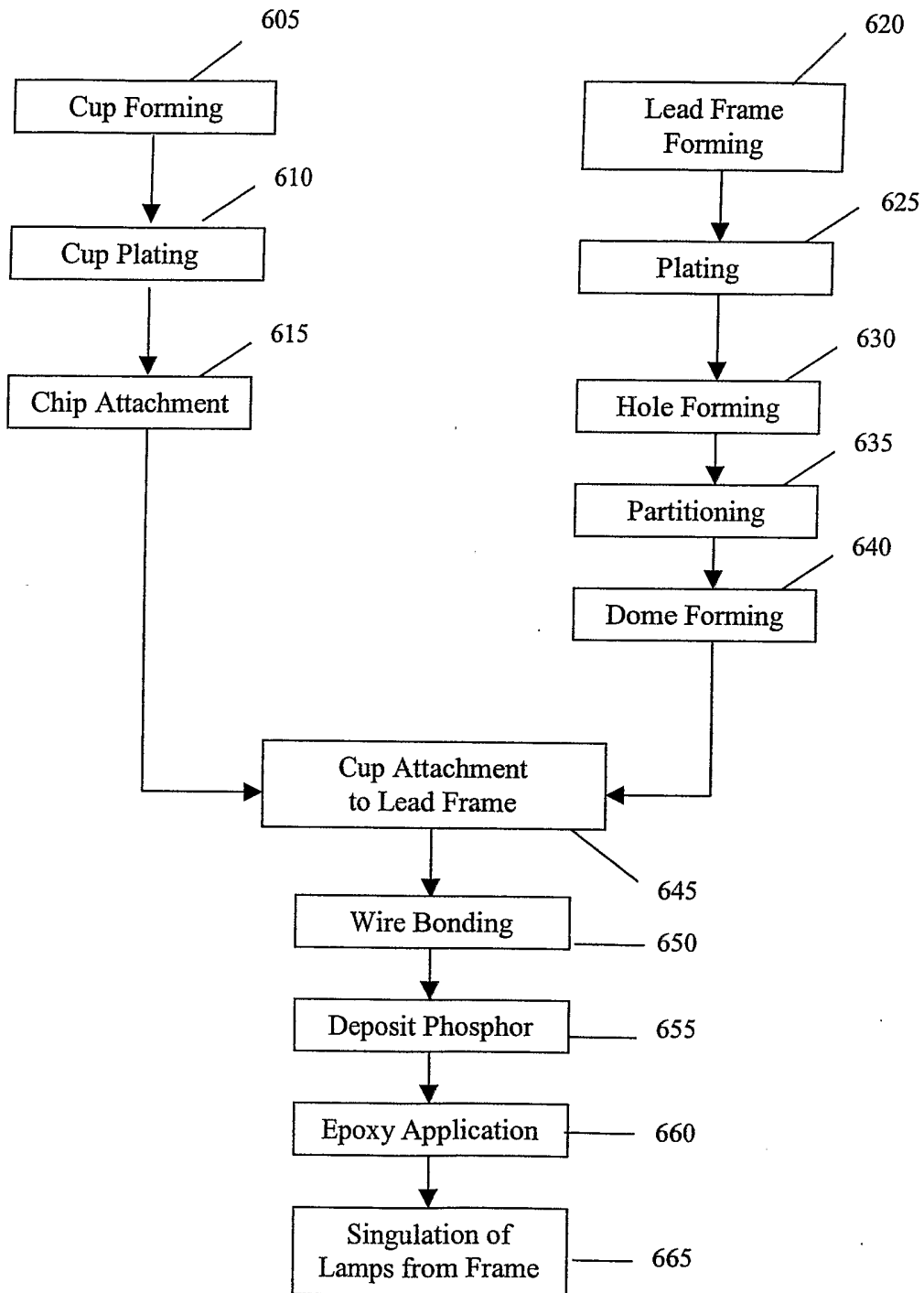

FIGURE 6

Lead Frame Forming

1. Raw Materials

Copper
Silver
Solder
Adhesive



2. Lead Frame Forming

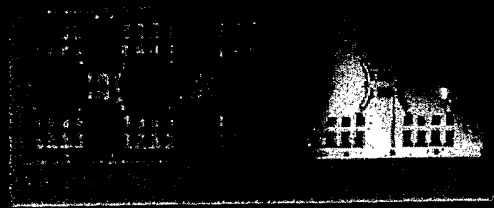

- Prototypes are manufactured using etching process
- Production process needs to be automated with high speed tooling



STEP 620

FIGURE 7

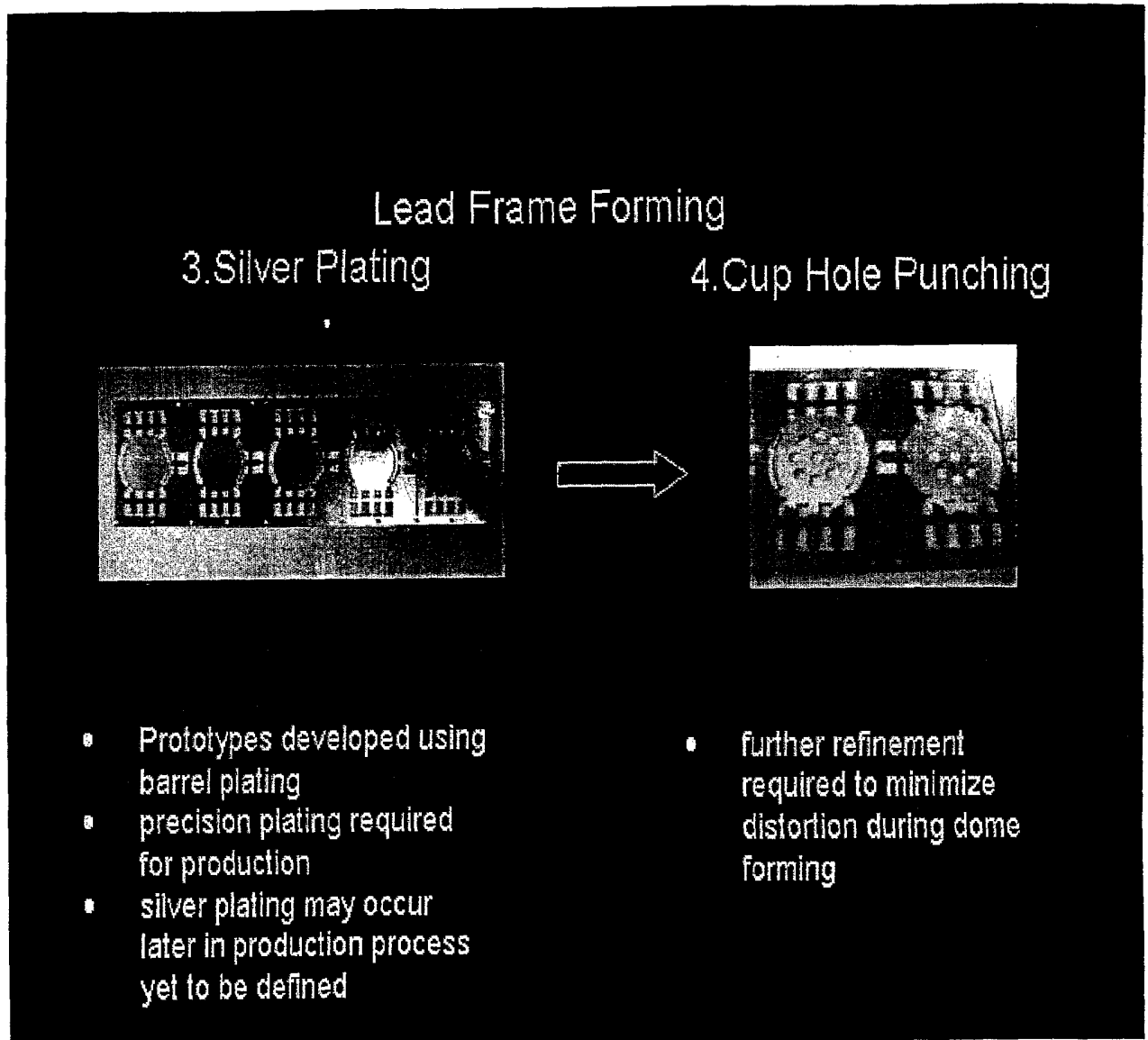

↑
STEP 625

↑
STEP 630

FIGURE 8

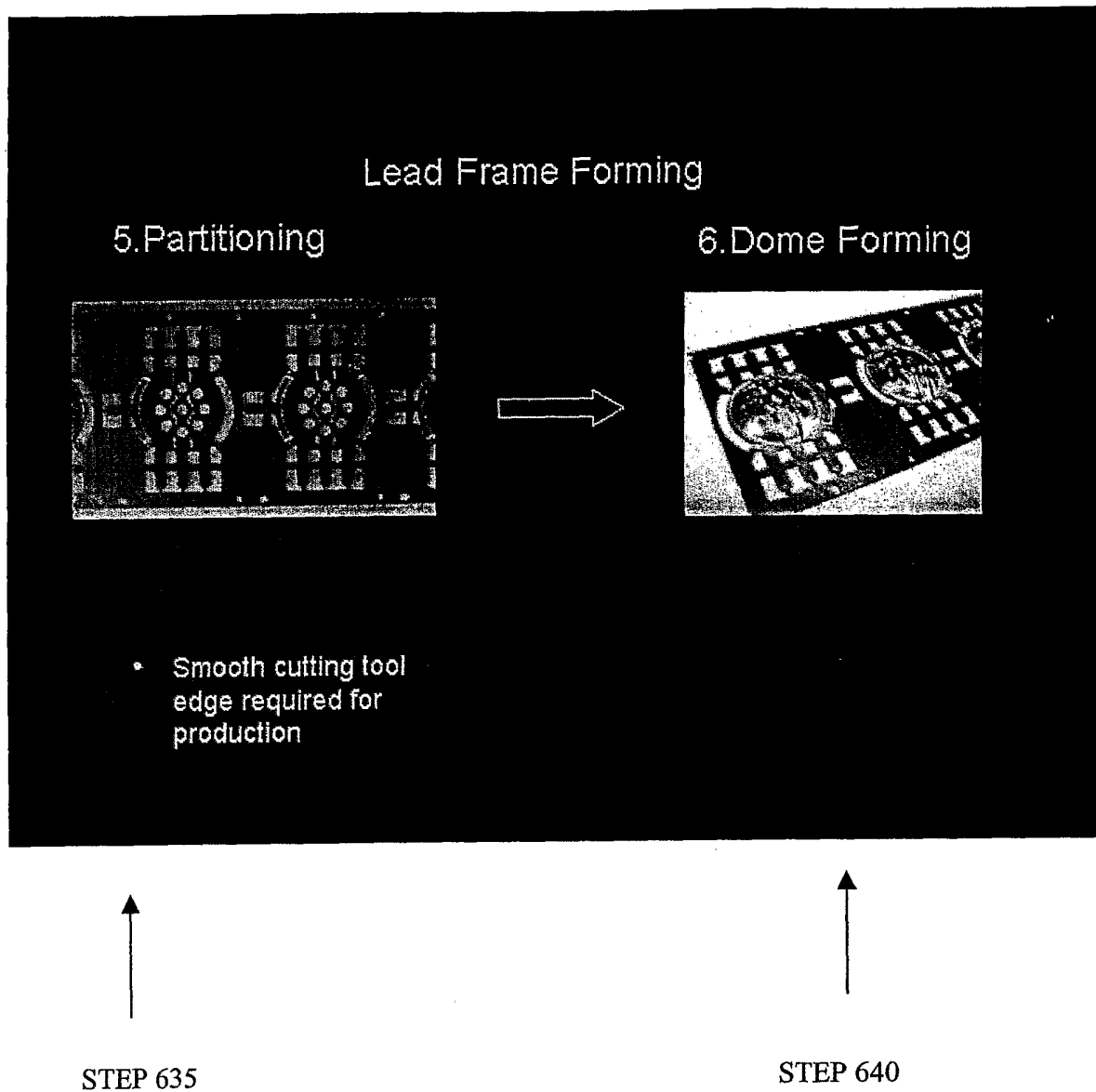

FIGURE 9

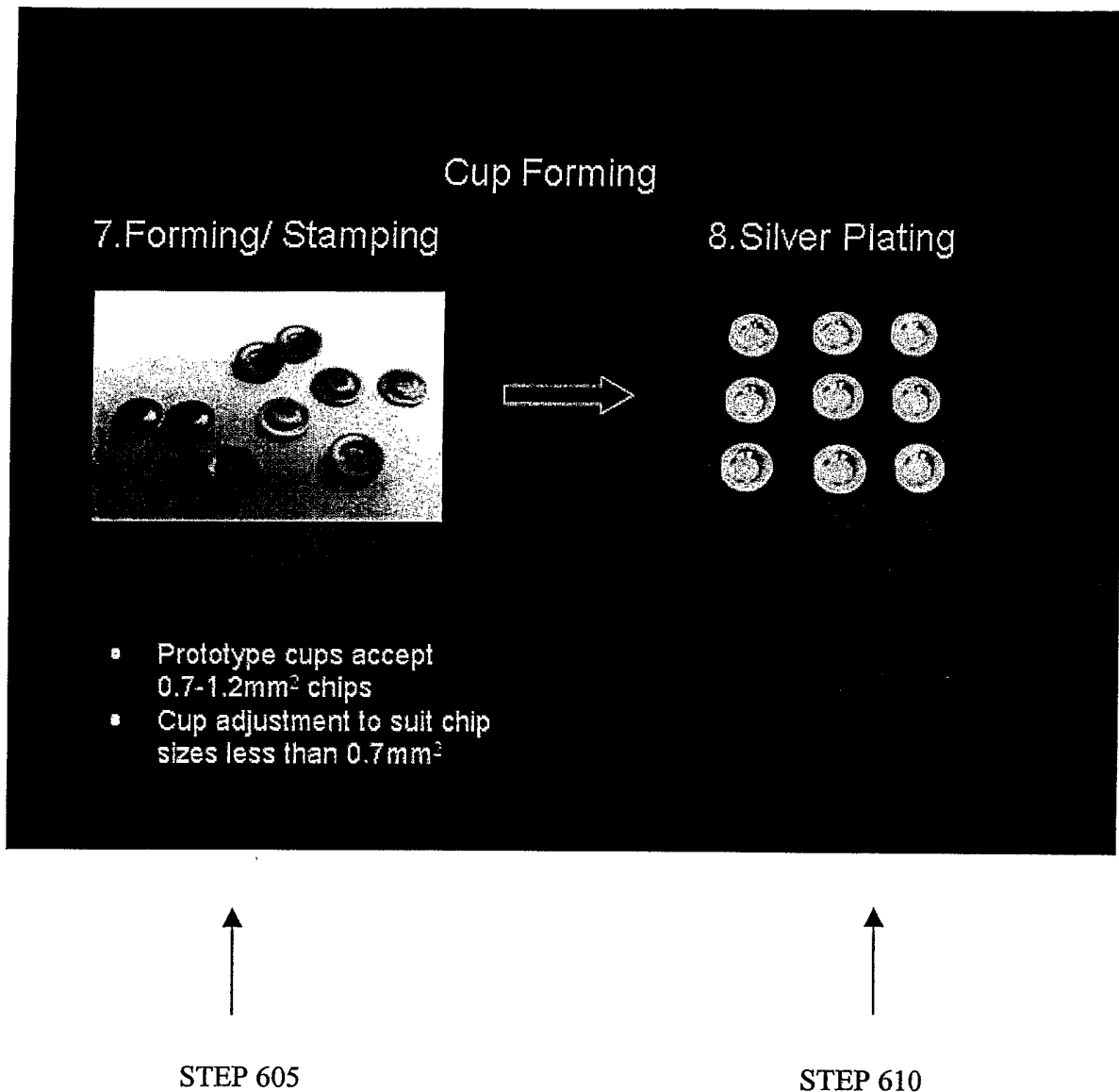
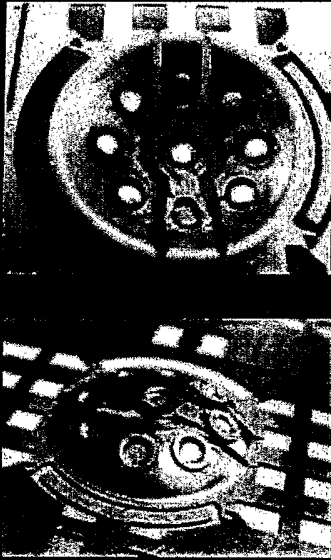

FIGURE 10

Cup Attachment

9. Attachment to Lead frame



- Surface mount technology
- Furnace curing
- Heat treatment unsatisfactory (200°C)
- Process and method of cup attachment needs refinement
- Solder used in cup attachment needs to withstand 220°C
- Silver plating corrosion during heating process. Require clinical surface finish at bonding joints.



STEP 645

FIGURE 11

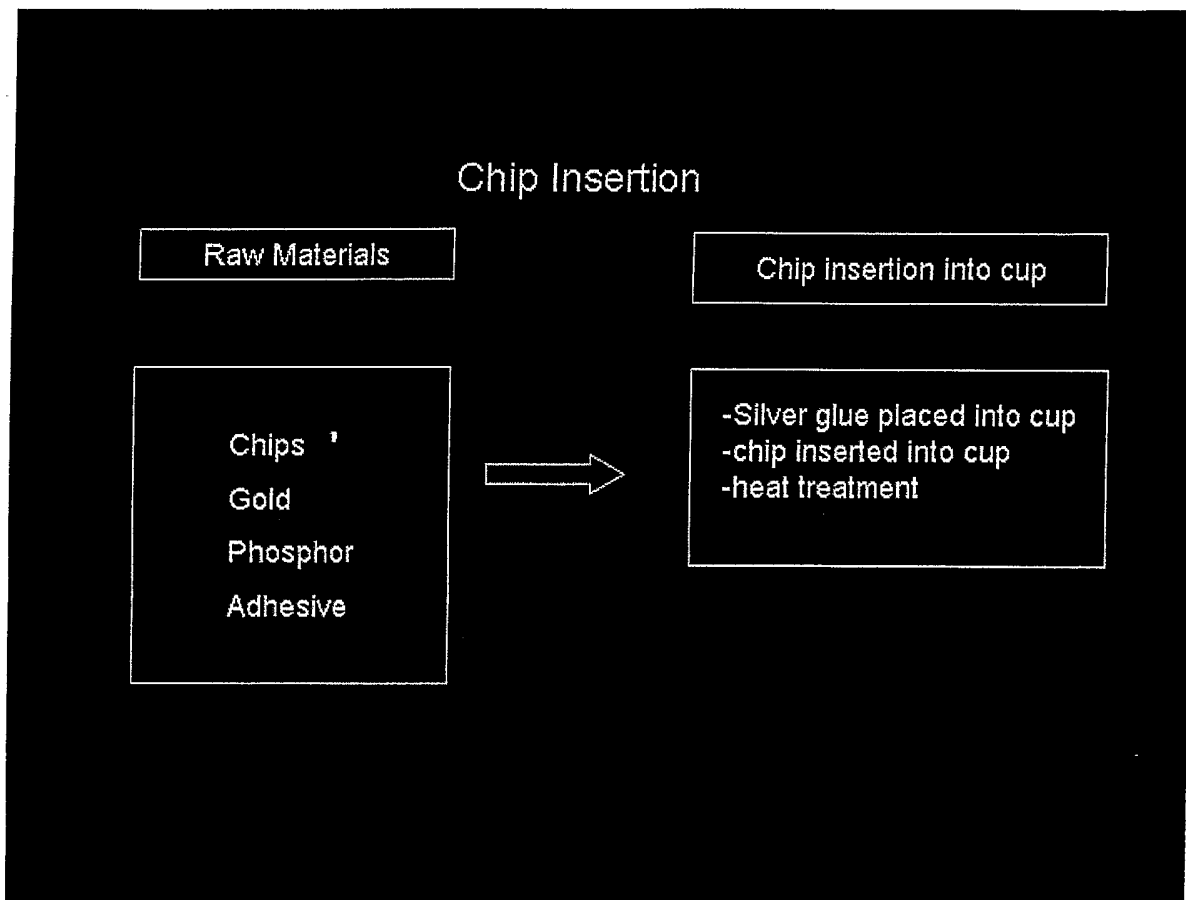

↑
STEP 615

FIGURE 12

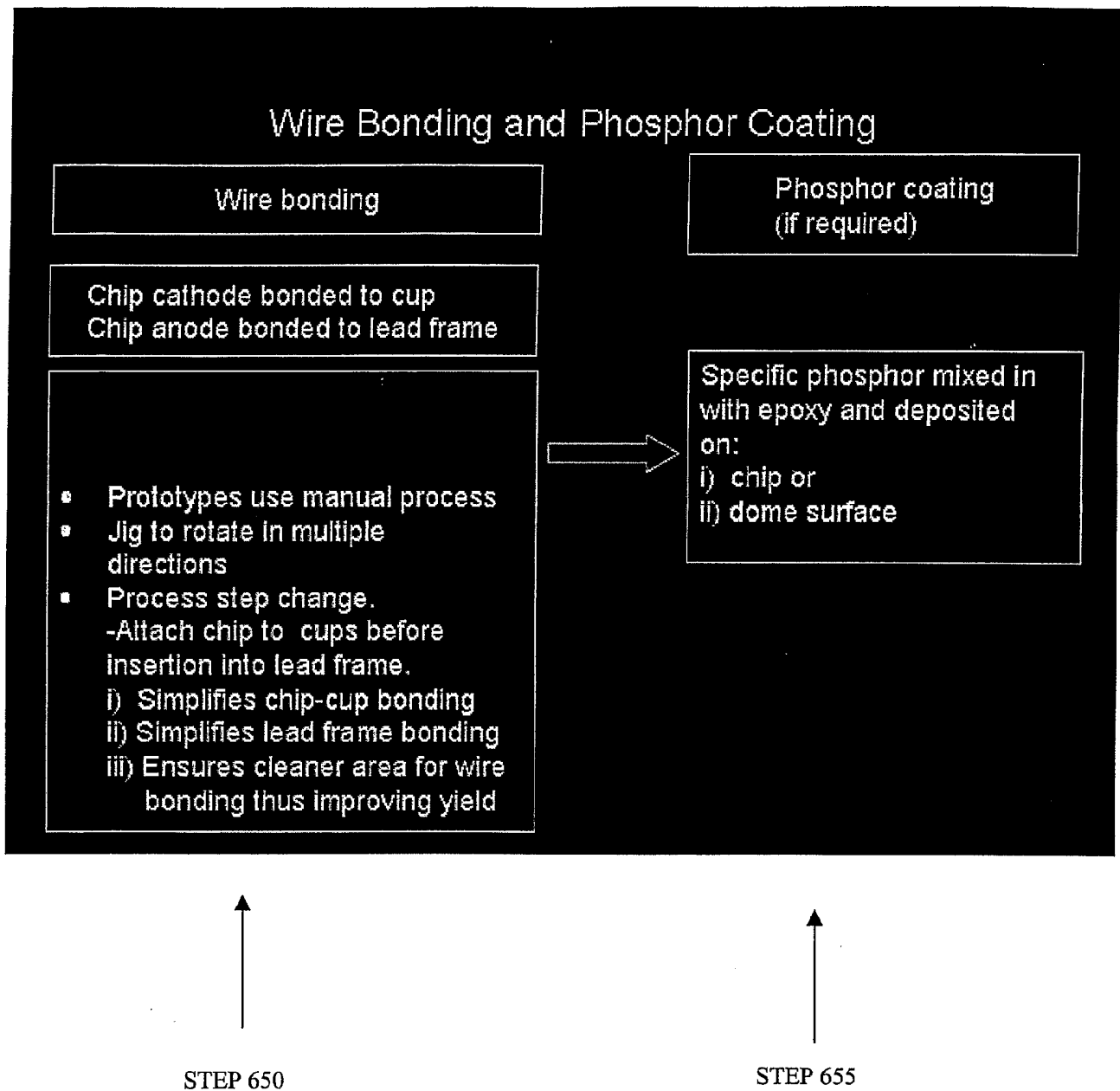

FIGURE 13

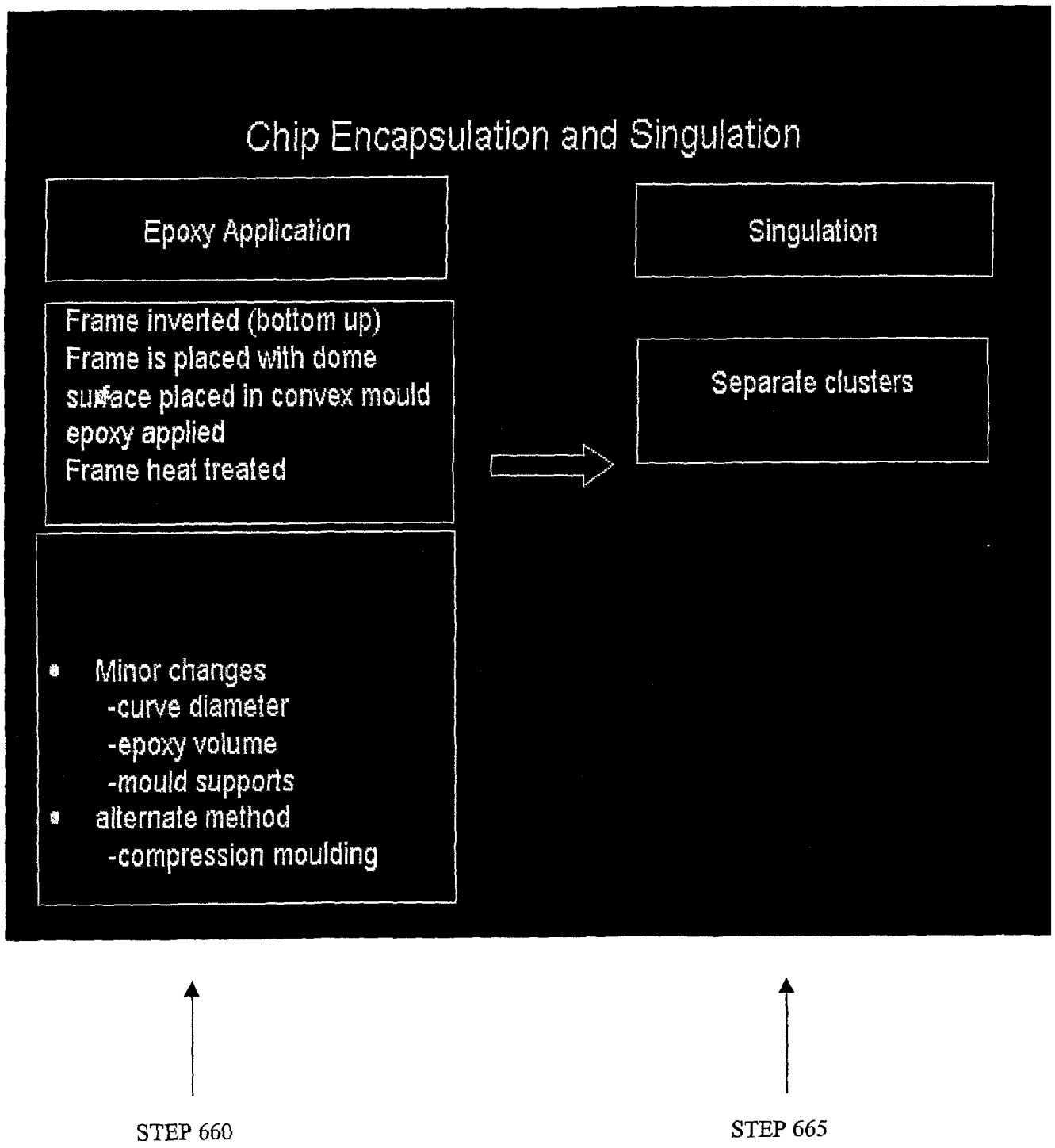

FIGURE 14

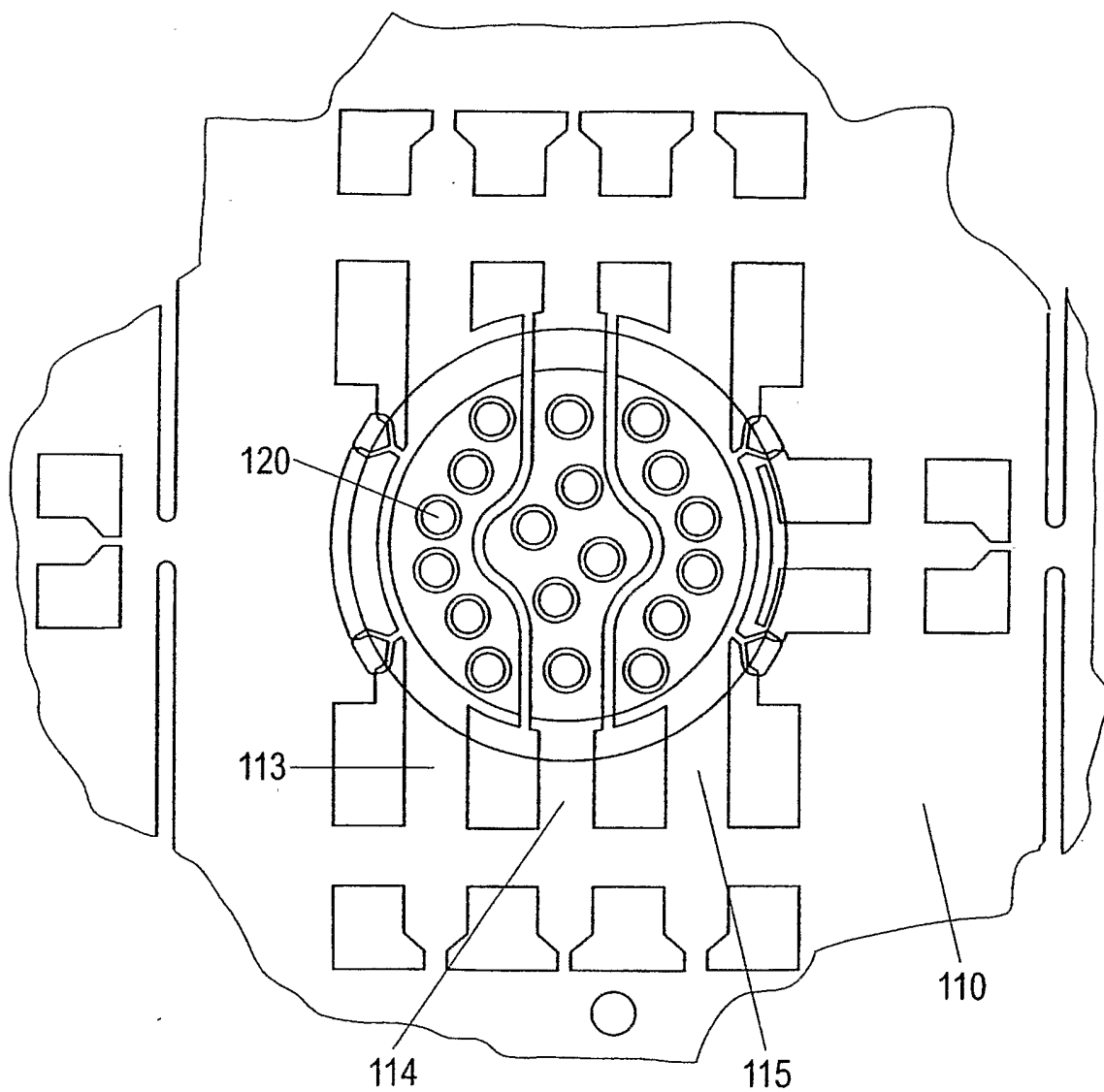

FIGURE 15

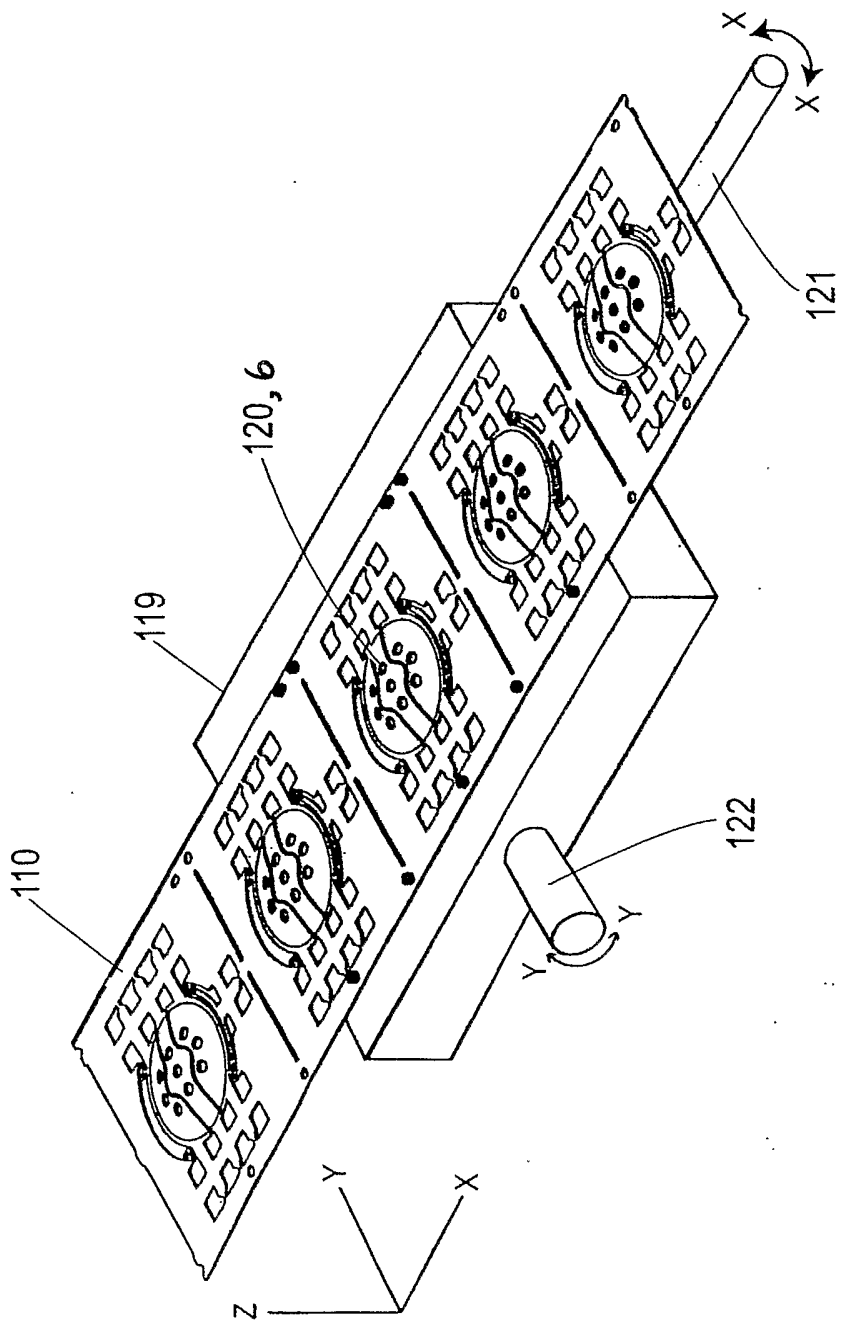

FIGURE 16

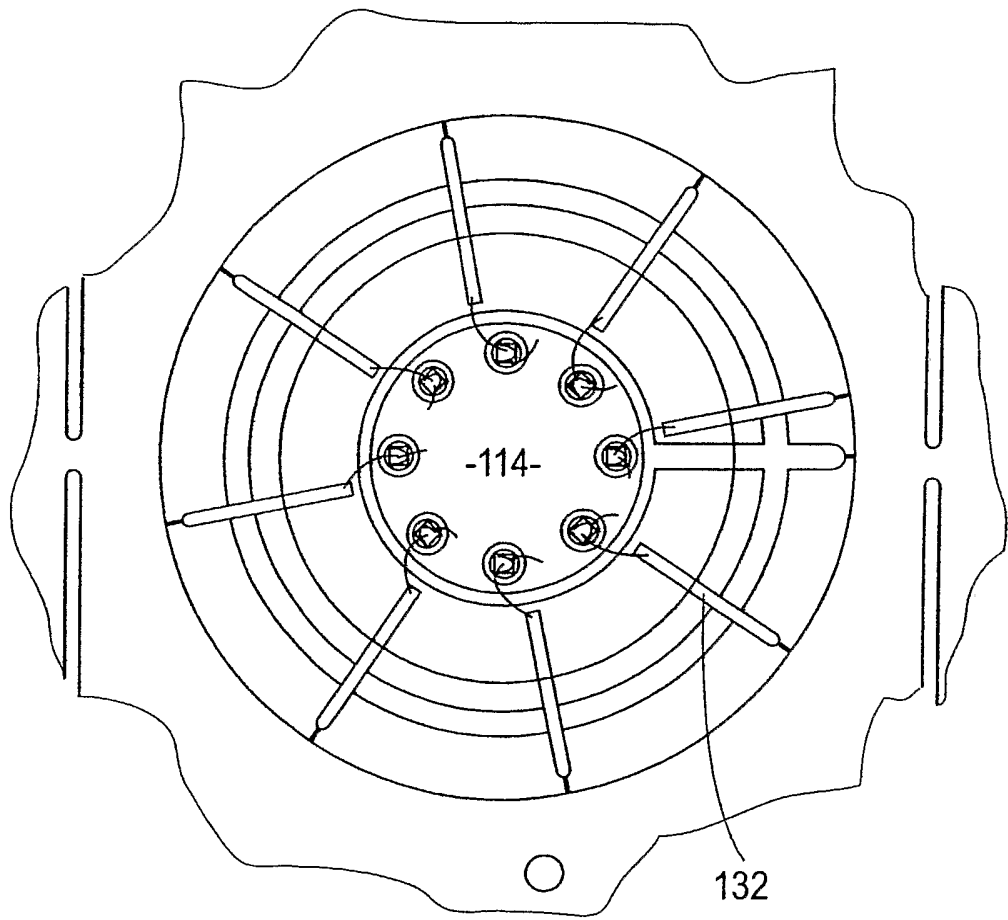
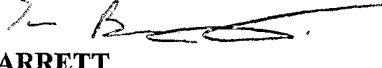

FIGURE 17

INTERNATIONAL SEARCH REPORT

International application No.

PCT/AU03/00724

A. CLASSIFICATION OF SUBJECT MATTER		
Int. Cl. ⁷ : H01L 25/075, 23/495		
According to International Patent Classification (IPC) or to both national classification and IPC		
B. FIELDS SEARCHED		
Minimum documentation searched (classification system followed by classification symbols)		
Documentation searched other than minimum documentation to the extent that such documents are included in the fields searched		
Electronic data base consulted during the international search (name of data base and, where practicable, search terms used) DWPI, JAPIO:- (H01L 23/495, leadframe), (curv+, concav+, convex, spher+, three dimensional etc), (hole, aperture, cavity etc), (LED, light emitting diode/junction), H01L 25/075, (cup, recess+, hollow etc), (chip, die, junction), (mount supprt, base etc)		
C. DOCUMENTS CONSIDERED TO BE RELEVANT		
Category*	Citation of document, with indication, where appropriate, of the relevant passages	Relevant to claim No.
P,X	US 2002/0113244 A1 (BARNETT et al) 22 August 2002 See the abstract, fig 11	1-17,22-39,43,44
P,X	WO 02/103794 A1 (SYSTEMAX PTY. LTD.) 27 December 2002 See entire specification	47-50
X	WO 01/97287 A1 (SYSTEMAX PTY. LTD.) 20 December 2001 See the abstract, figures 9-15	47-50
<input checked="" type="checkbox"/> Further documents are listed in the continuation of Box C <input checked="" type="checkbox"/> See patent family annex		
* Special categories of cited documents: "A" document defining the general state of the art which is not considered to be of particular relevance "E" earlier application or patent but published on or after the international filing date "L" document which may throw doubts on priority claim(s) or which is cited to establish the publication date of another citation or other special reason (as specified) "O" document referring to an oral disclosure, use, exhibition or other means "P" document published prior to the international filing date but later than the priority date claimed "T" later document published after the international filing date or priority date and not in conflict with the application but cited to understand the principle or theory underlying the invention "X" document of particular relevance; the claimed invention cannot be considered novel or cannot be considered to involve an inventive step when the document is taken alone "Y" document of particular relevance; the claimed invention cannot be considered to involve an inventive step when the document is combined with one or more other such documents, such combination being obvious to a person skilled in the art "&" document member of the same patent family		
Date of the actual completion of the international search 18 July 2003		Date of mailing of the international search report 28 JUL 2003
Name and mailing address of the ISA/AU AUSTRALIAN PATENT OFFICE PO BOX 200, WODEN ACT 2606, AUSTRALIA E-mail address: pct@ipaaustralia.gov.au Facsimile No. (02) 6285 3929		Authorized officer  I.A. BARRETT Telephone No : (02) 6283 2189

INTERNATIONAL SEARCH REPORT

International application No.

PCT/AU03/00724

C (Continuation). DOCUMENTS CONSIDERED TO BE RELEVANT		
Category*	Citation of document, with indication, where appropriate, of the relevant passages	Relevant to claim No.
X	Patent Abstracts of Japan, JP 61-141165 A (TOSHIBA CORP) 28 June 1986 See the abstract, holes 26a, 26b	47-50
A	US 2002/0042156 A1 (CHEN) 11 April 2002 See the abstract	
A	US 6367949 B1 (PEDERSON) 9 April 2002 See the abstract	
A	US 5534718 A (CHANG) 9 July 1996 See the abstract	
A	US 4935665 A (MURATA) 19 June 1990 See the abstract	
A	US 3875456 A (KANO et al) 1 April 1975 See the abstract	
A	WO 97/12386 A2 (SIEMENS AKTIENGESELLSCHAFT) 3 April 1997 See the abstract	
A	FR 2518317 A1 (LICENTIA PATENT-VERWALTUNGS-GMBH) 17 June 1983 See the claims, figures 1-5	
P,A	Patent Abstracts of Japan, JP 2003-031005 A (RABO SUFIA KK) 31 January 2003 See the abstract	
P,A	Patent Abstracts of Japan, JP 2002-336275 A (YOSHIDA DENTAL MFG CO LTD) 26 November 2002 See the abstract	
A	Derwent Abstract Accession No. 99-173233/15, Class T01, JP 11026816 A (CITIZEN DENSHI KK) 29 January 1999 See the abstract	

INTERNATIONAL SEARCH REPORT

Information on patent family members

International application No.

PCT/AU03/00724

This Annex lists the known "A" publication level patent family members relating to the patent documents cited in the above-mentioned international search report. The Australian Patent Office is in no way liable for these particulars which are merely given for the purpose of information.

Patent Document Cited in Search Report	Patent Family Member			
US 2002113244	WO	2002069409		
WO 2002103794	AU	20015705		
WO 200197587	AU	200164291		
JP 61141165	NONE			
US 2002042156	NONE			
US 6367949	US	2002048174	US	2002071268
	US	6461008	US	6476726
	US	2003025608	WO	200110674
	WO	200110676	US	2002093820
			US	2003021121
			WO	200110675
US 5534718	NONE			
US 4935665	JP	2078102	JP	1309201
			JP	1311501
US 3875456	JP	48102585		
WO 9712386	DE	19536454	EP	852816
	US	6459130	EP	1199753
FR 2518317	DE	3148843		
JP 2003031005	NONE			
JP 2002336275	NONE			
JP 11026816	NONE			
END OF ANNEX				