

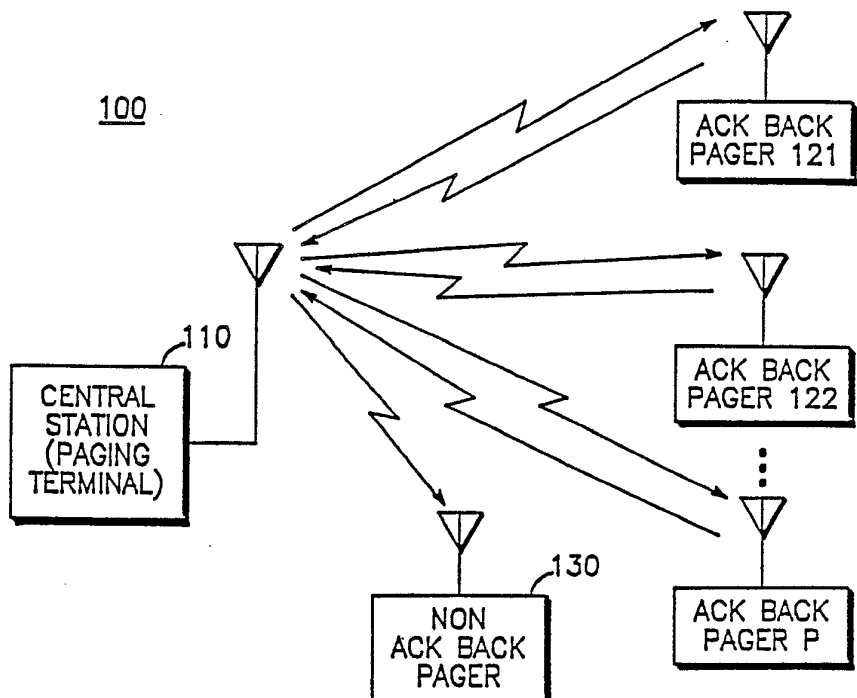

INTERNATIONAL APPLICATION PUBLISHED UNDER THE PATENT COOPERATION TREATY (PCT)

<p>(51) International Patent Classification ⁴ : G08B 5/22</p>	<p>A1</p>	<p>(11) International Publication Number: WO 89/ 06407 (43) International Publication Date: 13 July 1989 (13.07.89)</p>
<p>(21) International Application Number: PCT/US88/04336 (22) International Filing Date: 5 December 1988 (05.12.88) (31) Priority Application Number: 141,656 (32) Priority Date: 7 January 1988 (07.01.88) (33) Priority Country: US (71) Applicant: MOTOROLA, INC. [US/US]; 1303 East Algonquin Road, Schaumburg, IL 60196 (US). (72) Inventor: SIWIAK, Kazimierz ; 10988 N.W. 14th Street, Coral Springs, FL 33071 (US). (74) Agents: PARMELEE, Steven, G. et al.; Motorola, Inc., Intellectual Property Dept., 1303 East Algonquin Road, Schaumburg, IL 60196 (US).</p>		<p>(81) Designated States: AT (European patent), AU, BE (European patent), CH (European patent), DE (European patent), FR (European patent), GB (European patent), IT (European patent), JP, KR, LU (European patent), NL (European patent), SE (European patent). Published <i>With international search report. Before the expiration of the time limit for amending the claims and to be republished in the event of the receipt of amendments.</i></p>

(54) Title: CODE DIVISION MULTIPLEXED ACKNOWLEDGE BACK PAGING SYSTEM



(57) Abstract

An acknowledge back (ack-back) paging system (100) is provided which includes a central station (110) which transmits a group of message signals to a group of ack-back pagers (121, 122,...) which are addressed as a group. The users of the group of addressed ack-back pagers indicate a response to their respective pagers thus providing ack-back data. The pagers in the group of addressed ack-back pagers then simultaneously transmit back to the central station their ack-back signals using different respective pseudorandom codes, a different pseudorandom code being dynamically allocated to each of the pagers in the group.

FOR THE PURPOSES OF INFORMATION ONLY

Codes used to identify States party to the PCT on the front pages of pamphlets publishing international applications under the PCT.

AT	Austria	FR	France	ML	Mali
AU	Australia	GA	Gabon	MR	Mauritania
BB	Barbados	GB	United Kingdom	MW	Malawi
BE	Belgium	HU	Hungary	NL	Netherlands
BG	Bulgaria	IT	Italy	NO	Norway
BJ	Benin	JP	Japan	RO	Romania
BR	Brazil	KP	Democratic People's Republic of Korea	SD	Sudan
CF	Central African Republic	KR	Republic of Korea	SE	Sweden
CG	Congo	LI	Liechtenstein	SN	Senegal
CH	Switzerland	LK	Sri Lanka	SU	Soviet Union
CM	Cameroon	LU	Luxembourg	TD	Chad
DE	Germany, Federal Republic of	MC	Monaco	TG	Togo
DK	Denmark	MG	Madagascar	US	United States of America
FI	Finland				

CODE DIVISION MULTIPLEXED
ACKNOWLEDGE BACK PAGING SYSTEM

BACKGROUND OF THE INVENTION

5

This invention relates in general to radio communications systems. More particularly, the invention relates to radio paging systems.

10 In the past several years, radio paging technology has advanced from the rather simple tone-only pager (tone alert only, no voice), to the tone and voice pager (tone alert with a voice message) and more recently to the alphanumeric display pager. In a typical conventional alphanumeric display paging system such as that shown as system 10 in FIG. 1, a
15 central transmitter or paging terminal 20 is used to generate the radio pages which are transmitted via a radio link to a fleet of paging receivers 1, 2, 3 ...N, wherein N is the total number of pagers in system 10. A unique digital address is associated
20 with each of paging receivers 1, 2, 3...N. A page which is transmitted by paging terminal 20 consists of the unique digitally encoded address of the particular pager to which the page is targeted,
25 immediately followed by a corresponding digitally encoded numeric or alphanumeric page message which is intended for display on the target pager.

Typically, the numeric or alphanumeric page message is stored in a memory within the paging receiver for later recall and display by the pager user. Paging receivers are available with a wide
5 range of message storage capabilities which range from the ability to store just a few rather short numeric page messages to the ability to store a relatively large number of longer alphanumeric page messages.

10 However, conventional display paging systems are generally one way systems. That is, the user receives a paging message from the central terminal but has no way of responding to that message with his or her pager. Instead, the pager user must seek out
15 a telephone or other means of responding to the originator of the paging message.

BRIEF SUMMARY OF THE INVENTION

20 Accordingly, it is one object of the present invention is to provide a paging system in which the radio pager is capable of responding back to the paging terminal and the caller.

25 Another object of the present invention is to provide a radio paging system in which a group of addressed pagers are capable of simultaneously transmitting acknowledge back signals on a selected frequency, each pager transmitting a respective
30 acknowledge back signal using a different substantially orthogonal pseudorandom code.

In one embodiment of the invention, an acknowledge back pager is provided which has a unique address associated therewith. The pager includes a

receiver for receiving paging signals from a central station. The paging signals including a batch of M pager addresses transmitted in a sequential order during a first time period, wherein M is the number of pager addresses in the batch. The pager further includes a decoder, coupled to the receiver, for detecting the presence of the pager's address within the batch of M addresses. The pager includes an address order determining apparatus, coupled to the decoding means, for determining the order of the pager's address within the batch of M addresses. The pager further includes a pseudorandom code transmitter for transmitting an acknowledge back signal at a selected frequency, such acknowledge back signal including a selected one of a plurality of M substantially orthogonal pseudorandom codes. The selected one of the codes exhibits a predetermined relationship to the order of the address of the pager within the batch of M addresses.

The features of the invention believed to be novel are specifically set forth in the appended claims. However, the invention itself, both as to its structure and method of operation, may best be understood by referring to the following description and the accompanying drawings.

BRIEF DESCRIPTION OF THE DRAWINGS

FIG. 1 is a block diagram of a conventional display type radio paging system.

FIG. 2 is a block diagram of the ack-back paging system of the present invention.

FIG. 3 is a block diagram of the central station employed in the paging system of FIG. 2.

FIG. 4A is a time vs. event representation of the transmissions from the central station of the system of the invention.

5 FIG. 4B is a representation of an address block used in the paging protocol of the paging system of the invention.

FIG. 4C is a representation of a message block used in the paging protocol of the paging system of the invention.

10 FIG. 4D is a time vs. event representation of the receiver portion of the central station.

FIG. 4E is a time vs. event representation of the activity of ack-back pager AB-1.

15 FIG. 4F is a time vs. event representation of the activity of ack-back pager AB-2.

FIG. 4G is a time vs. event representation of the activity of ack-back pager AB-M.

20 FIG. 4H is a time vs. event representation of the activity of a non ack-back pager in the paging system of the invention.

FIG. 4I is a time vs. event representation of the activity of an unpagged ack-back pager in the paging system of the invention.

25 FIG. 5 is a flowchart depicting the operation of the central station in the paging system of the invention.

FIG. 6 is a block diagram of one of the ack-back pagers employed in the paging system of the invention.

30 FIG. 7 is pseudorandom (PN) code look-up table employed by the ack-back pagers in the system of the invention.

35 FIG. 8 is a flowchart of the operation of the ack-back pagers of the paging system of the invention.

DETAILED DESCRIPTION OF THE INVENTION

FIG. 2 is a simplified block diagram of the acknowledge back paging system 100 of the present invention. Paging system 100 includes a central station or paging terminal 110 which is capable of both transmitting outgoing paging signals and of receiving acknowledge back (ack-back) paging signals. Paging system 100 includes a plurality of ack-back pagers 121, 122...P, wherein P is the total number of ack-back pagers in the pager population of system 100. Each of ack-back pagers 121, 122...P has the capability of receiving paging signals from central station 110 and of permitting the pager user to respond to such paging signals. That is, pagers 121, 122...P permit the user to reply or acknowledge back to a page from central station 110. It is noted that conventional non ack-back pagers such as pager 130 are also includable in system 100. In FIG. 2, double arrows between central station 110 and each of ack-back pagers 121, 122...P are used to denote that two way communication exists between central station 110 and such ack-back pagers. A single arrow denotes that only one way communication exists between station 110 and pager 130.

FIG. 3 is a more detailed block diagram of central station or paging terminal 110. Central station 110 includes a conventional telephone interface 140 of the type generally used for central paging terminals. Telephone interface 140 couples outside telephone lines 141, 142, etc. to an input 150A of a microcomputer 150. Telephone interface 140 converts message signals from lines 141, 142, etc. to digital signals which microcomputer 150 can process. For example, a caller wishing to send an alphanumeric

page to an ack-back pager user uses dual tone multi frequency (DTMF) to key in a desired message. Telephone interface 140 then converts such analog DTMF alphanumeric message to its digital equivalent which microcomputer 150 processes as discussed later in more detail. Central station 110 further includes a keyboard 160 coupled to a data input 150B of microcomputer 150. Keyboard 160 permits an operator to directly input messages into microcomputer 150 for transmission to pagers within the pager population.

A read only memory (ROM) 170 is coupled to a memory port 150C of microcomputer 150. ROM 170 includes a control program which controls the operation of microcomputer 150 and the circuits coupled thereto. A random access memory (RAM) 180 is coupled to a memory port 150D microcomputer 150. RAM 180 provides temporary storage space for microcomputer 150 as it carries out the instructions of the control program within ROM 170.

When a paging message and the identity of the particular pager to be addressed are provided to microcomputer 150, the control program causes microcomputer 150 to generate digital paging signals at its output 150E according to the protocol later described. Microcomputer output 150E is coupled via a level shifter 190 to the input of a transmitter 200. The output of transmitter 200 is coupled to an antenna 210 having dimensions and characteristics appropriate to the particular paging frequency channel selected for the operation of central station 110. Level shifter 190 serves to adjust the signal level of the paging signals generated at microcomputer output 150E to a level appropriate for the input of transmitter 200.

For purposes of this example, it will be assumed that ack-back pagers 121, 122-P are acknowledging back via phase shift keyed (PSK) digital modulation. Those skilled in the art will appreciate that other forms of modulation as well may be employed by
5 acknowledge back pagers 121, 122-P to respond to the paging signals transmitted by central station 110. In such a PSK embodiment, central station 110 includes a receive antenna 220 for receiving the ack-
10 back signals transmitted by ack-back pagers 121, 122-P. In actual practice, antenna 210 may also be employed as antenna 220. Receive antenna 220 is coupled to the input of a PSK receiver 230 which includes an in-phase (I) output 230A and a quadrature
15 (Q) output 230B. Receiver outputs 230A and 230B are respectively connected to inputs 240A and 240B of digital signal processor 240. One digital signal processor which may be employed as processor 240 is the model DSP56000 manufactured by Motorola, Inc.
20 Digital signal processor 240 includes a control input 240C which is coupled to a control output 150F of microcomputer 150 to permit microcomputer 150 to control processor 240. Digital signal processor 240 further includes a data output 240D which is coupled
25 to the data input 150G of microcomputer 150. Thus, it is seen that digital signal processor 240 decodes the digital data received at the I and Q inputs 240A and 240B thereof and transforms such information into digital data which is provided to microcomputer data
30 input 150G.

FIG.'s 4A-4I are timing diagrams which show the signaling protocol employed by central station 110 and ack-back pagers 121, 122-P. More specifically, FIG. 4A is a simplified timing diagram of the paging
35 protocol transmitted by central station 110. In FIG.

4A, time is represented on the horizontal axis and respective events are denoted as they occur at designated points in time along such time axis. Central station 110 first transmits a preamble signal 300 during a time interval T1. In one embodiment, preamble symbol 300 consists of a plurality of alternating 0's and 1's transmitted for a duration of time T1. For example, preamble symbol is a 010101... signal.

10 In accordance with the present invention, central station 110 groups paging addresses into groups of M wherein M is the number of paging addresses in a particular group. For purposes of this example, and not by way of limitation, the number of paging addresses and thus the number of messages corresponding to such addresses is selected to be 20 (that is, M=20). That is, as messages are called into central station 110 via telephone interface 140 or keyboard 160, such paging messages and corresponding address information are held or stored in RAM 180 until a group of up to M=20 messages has been provided to station 110. In alternative embodiments of the invention, non ack-back pages may be interspersed with ack-back pages to increase the efficient throughput of the paging system if desired as will be discussed later. The group of M=20 ack-back pagers is a subgroup of the overall population of P pagers. Once station 110 has received 20 or M paging messages, microcomputer 150 sequentially transmits the 20 corresponding addresses as a group 310 during a time interval T2 subsequent to time interval T1 as shown in FIG. 4A.

FIG. 4B shows the sequential relationship of each of the addresses within group 310. The address of the first pager of the group of M pagers to be

addressed is designated address 1 and is transmitted first in group 310 as shown. The pager to which address 1 corresponds is designated AB-1 for reference. The address of second pager of the group of M selected ack-back pagers is designated address 2 and is transmitted immediately following address 1. The pager to which address 2 corresponds is designated pager AB-2. This process of address transmission continues sequentially in the same fashion until all of the addresses of the group of M pagers are transmitted ending with address M, the address of the last or M'th pager in group 310. The pager to which address M corresponds is designated pager AB-M. A non-ack back pager AB-3 is shown addressed in the block of M pages as will be described later in the discussion of FIG. 4H.

In one embodiment of the invention, the duration of time during which preamble signal 300 is transmitted, namely T1, is approximately equal to 10 msec. Those skilled in the art will appreciate that T1 may have values greater than or less than 10 msec providing T1 is sufficiently long to permit the ack-back receivers 121, 122...P to synchronize to the paging signals transmitted by central station 110. Apparatus for synchronizing paging receivers to paging signals is well known to those skilled in the art and is included in ack-back pagers 121, 122...P.

For purposes of example, the time duration T2 of the group 310 of addresses is selected to be approximately equal to 1 sec. Those skilled in the art will appreciate that T2 may actually be greater or less than 1 sec depending upon the number of paging addresses M selected to be in the group 310 and the frequency of transmission of the digital data comprising such paging addresses. The selection of

the time period T2 in this example should not be taken as in any way limiting the invention. To reiterate, the particular pagers of the population P which are addressed in address block 310 are
5 designated as pagers AB-1 (the first pager to be addressed), pager AB-2 (the second pager to be addressed)...pager AB-M (the last pager addressed of the group of M pagers).

After transmission of the group of M addresses,
10 central station 110 transmits a reference carrier signal at a frequency F_{RX} at 320 during a time interval T3 following time interval T2. Subsequent to transmission of reference carrier 320, central station 110 sequentially transmits the 20 paging
15 messages corresponding to the 20 paging addresses of address group or block 310. More specifically, these M or 20 data messages are sent as a group or block 330 of messages. Each of the M messages in block 330 bears a predetermined relationship to the order of
20 the pager addresses in block 310. For example, in one embodiment of the invention and as shown more clearly in FIG. 4C, message block 330 includes message 1 data followed in time by an end of message (EOM) field. The EOM field of message 1 is followed
25 sequentially in time by the message 2 data which is in turn followed by another EOM field. The process of sending the respective messages 3, 4, etc. within message block 330 continues until message M is transmitted followed by a respective EOM field as
30 shown in FIG. 4C.

In the embodiment of the invention described above, the predetermined relationship between the sequence of messages transmitted in message block 330 and the sequence of pager addresses transmitted in
35 address block 310, is conveniently selected such that

address 1 is first transmitted in block 310 and the message 1 corresponding to such address 1 is transmitted first in the later following message block 330 occurring during time slot T4. To
5 illustrate this predetermined relationship further, address 2 is transmitted second, that is immediately after address 1 in address block 310. Correspondingly, in the later following time slot T4, message 2 is transmitted second, that is, immediately
10 following message 1's EOM field. The same relationship exists between the remaining addresses in block 310 and messages in block 330.

The invention, however, is not limited to the particular predetermined relationship described above
15 between the sequence of pager addresses in address block 310 and corresponding messages in message block 330. For example, in another embodiment of the invention, the sequence of pager addresses would remain as illustrated in FIG. 4B with address 1 being
20 sent first followed by address 2 and so forth until address M is transmitted completing the block. However, the sequential order in which the messages in message block 330 are transmitted in such
embodiment may commence with transmission of message
25 M first followed by message M-1 (or message 19) followed by message M-2 (18) and so forth until message 1 is finally transmitted at the end of message block 310. (EOM fields are still situated
between messages.) What is important here is that a
30 predetermined relationship exists between the order in which the paging addresses are transmitted in address block 310 to the order in which the paging messages are transmitted in message block 330 so as
to permit acknowledge back pagers AB-1, AB-2, ... AB-M
35 to match a particular message within block 330 to a

respective paging address of block 310. This enables a particular pager to determine which of the 20 paging messages in block 330 is intended for it, as will be discussed subsequently in more detail.

5 Although examples have been discussed above wherein the predetermined relationship between the order of the pager addresses of address block 310 and the paging messages of message block 330 are both ascending, and in the other example
10 ascending/descending, those skilled in the art will appreciate that an arbitrary relationship between the paging addresses on block 310 and the paging messages of block 330 may also be selected as long as this predetermined known relationship is programmed into
15 acknowledge back pagers 121, 122...P.

A reference carrier exhibiting a frequency of F_{RX} is generated during a period of time T_3 subsequent to the end of transmission of the pager addresses in address block 310. In one embodiment of
20 the invention, T_3 is equal to approximately 70 msec. Those skilled in the art will appreciate that T_3 may be longer or shorter than 70 msec providing the reference carrier shown at 320 exhibits a time
25 duration sufficiently long to enable frequency determining circuitry, later described, in ack-back pagers 121, 122...P to determine the frequency of reference carrier 320.

FIG. 4D is a time vs. event diagram of the status of receiver 230 in central station 110.
30 Subsequent to time period T_4 , receiver 230 at central station 110 is turned on to receive ack-back signals from the 20 pagers in the group of M during a time period T_5 . Each of the group of M ack-back message signals transmitted by the respective ack-back pagers
35 in the group of M employ a different respective

pseudorandom code within a common frequency channel as will be discussed in more detail subsequently. Receiver 230 is thus capable of distinguishing and decoding message signals coded with each of the 20 or
5 M different pseudorandom codes. The configuration and operation of receiver 230 is discussed in more detail later.

FIG. 4E is a time versus event diagram for the status of ack-back pager AB-1, that is, the first
10 addressed pager of the group of M pagers. FIG. 4E is drawn to the same time scale as FIG. 4A. During the T1 time interval, pager AB-1 receives the preamble at 340. During the following time period T2, pager AB-1 receives and decodes address 1, which in this example
15 is the address of pager AB-1. It is noted that prior to reception of the preamble at 340, pager AB-1 is in a "sleep" or "battery saver" state. That is, prior to such T1 time period, pager AB-1 and the other pagers of the population of P pagers, have several of
20 their power consuming circuits turned off or placed in low power consumption states. Those skilled in the art are already familiar with the powering down of radio pager circuits in order to achieve battery saving and thus exactly which circuits in the pager are powered down, and the degree to which they are
25 powered down, are not discussed here in detail. What is important, however, is that the ack-back pagers of the population of P pagers are placed in a "battery saving" state or "sleep state" during prescribed
30 periods of time such as that mentioned above and which will be later specified.

When pager AB-1 receives the preamble 340 during time period T1, pager AB-1 is switched from a battery saving state to a fully operational state
35 such that pager AB-1 is capable of receiving

information transmitted thereto. That is, subsequent to reception of the preamble at 340, pager AB-1 is fully turned on such that pager AB-1 receives and decodes its address at 350 at the beginning of the T2
5 time period. In one embodiment of the invention, pager AB-1 conveniently returns to the "sleep state" for the remainder of the T2 time period during which pager addresses are transmitted. Prior to receiving the reference carrier F_{RX} at time period T3, pager
10 AB-1 is returned from the "sleep state" to the fully operational state. Upon reception of the reference carrier, F_{RX} at 360, pager AB-1 determines the frequency of such carrier in a manner described in more detail subsequently.

15 Referring to FIG. 4E, in conjunction with 4C, it is seen that the message 1 transmitted during time period T4 at 370 is received by pager AB-1 at 380 as shown in FIG. 4E. Pager AB-1 receives message 1 at 380 and matches message 1 to address 1. That is, by
20 means later described in more detail, pager AB-1 is programmed to determine that message 1 is the particular message of the group of M messages which is intended for pager AB-1. Subsequent to reception and display of message 1 at 380 as shown in FIG. 4E,
25 the user of pager AB-1 indicates his or her response to message 1 during a time period T6 at 385. Time period T6 is not drawn to scale with respect to the other time periods discussed. Time period T6 is sufficiently long to permit indication of a response
30 by the pager user. Subsequent to time period T6, pagers AB-1, AB-2 ... AB-M simultaneously transmit acknowledge back signals with respective pseudorandom codes back to central station 110 as at 390 during a
35 time period T5. Subsequent to the ack-back transmission at 390, pagers AB-1, AB-2 ... AB-M are

placed in the "sleep state" until awakened again by a preamble as at 340. In an alternative embodiment of the invention, ack-back pagers AB-1...AB-20 reply back automatically without action by the pager user.

5 In such an embodiment, prior to being paged, the user preselects a reply already stored in the pager or keys into the pager a predetermined message which the pager uses as the ack back reply when it is later addressed by central station 110. For example, the
10 ack-back pager user selects a "not available" response or otherwise keys into the pager a "not available" response when the pager user wishes to inform callers into central station 110 that the pager user is not taking any calls currently.

15 Clearly, the reply data may be provided to the ack-back pagers in many different ways. In the case of a user selectable response already programmed into the pager, time period T6 can be arbitrarily short, that is just sufficiently long enough to permit
20 transmission of such a selectable response whose length is predetermined and known to the microcomputer 150 in central station 110.

FIG. 4F is a time versus event diagram of the status of ack-back pager AB-2, that is, the second
25 pager addressed of the group of M ack-back pagers. Pager AB-2 receives the preamble at 340 and then switches from a "sleep state" to a fully turned on state. Pager AB-2 receives address 1 (the address of pager AB-1) at 350. Pager AB-2 decodes such address
30 1 at 350 and determines that the decoded address is not its own address. At 400, pager AB-2 receives its own address, namely address 2. Pager AB-2 decodes and determines that address 2 is its own address. As with pager AB-1 of FIG. 4E, pager AB-2 of FIG. 4F
35 goes to the "sleep state" for the remainder of the T2

time period. Pager AB-2 "wakes up" in time for reception of the reference carrier F_{RX} at 360 during time period T3. As seen by examining FIG. 4F in conjunction with FIG. 4C, pager AB-2 receives the

5 AB-1 page data transmitted at 370 within time period T4. As explained in more detail subsequently, pager AB-2 determines that the AB-1 message data is not a match. That is, pager AB-2 determines that the pager AB-1 message data (message 1) is not intended for

10 pager AB-2. After the end of message (EOM) marker following message 1, pager AB-2 receives the AB-2 message data (message 2) at 410 within time period T4. Pager AB-2 determines that the message 2 data at 410 is a match and that such message 2 data is

15 intended for AB-2. The message 2 data is then displayed to the user of pager AB-2 who indicates an acknowledge back response to pager AB-2 during time period T6 at 415. During the subsequent time period T5, the acknowledge back message is sent to central

20 station 110. Such ack-back message is codes with a second pseudorandom code different from the first pseudorandom code with which pager AB-1 codes ack-back signals. Subsequent to transmission of the acknowledge back response at time period T5, pager

25 AB-2 is caused to go to sleep.

FIG. 4G is a time versus event diagram of the status of ack-back pager AB-M, the last of the group of M pagers to be addressed. Pager AB-M receives the preamble at 340 to switch it from a "battery saver state" to a fully operational state. Pager AB-M then

30 receives the 19 addresses of the other pagers in the group of M, such as at 350 and 400 until finally pager AB-M receives and decodes its own address at 420. Pager AB-M is thus signaled that a message for

35 it will be transmitted momentarily. Pager AB-M

receives the reference carrier signal F_{RX} at 360. Referring to FIG. 4G in conjunction with FIG. 4C, it is seen that pager AB-M receives message 1, message 2 ...message M-1 and determines that all of these
5 messages are not matches. That is, such page data messages are not intended for AB-M. Pager AB-M receives the page data message M transmitted at 430 (FIG. 4C) and received at 440 (FIG. 4G) within time period T4. Pager AB-M determines that such message M
10 at 440 is intended for pager AB-M and displays the contents as such message M to the pager user. During time period T6 at 415, the pager user supplies ack-back pager AB-M with an acknowledge back response. During the subsequent time period T5, pager AB-M
15 sends such acknowledge back response back to the central station 110 with a pseudorandom code M at 450 different from the pseudorandom codes with which the remaining ack-back pagers AB-1, AB-2 ... AB-(M-1) code their transmissions. Subsequent to the
20 transmission of the ack-back response at 450 during time period T5, pager AB-M switches to the "sleep state".

One embodiment of the invention accommodates the situation where one or more of pagers within the
25 group of M pagers are not ack-back pagers. For example, it will be assumed that pager AB-3 is not a pager with acknowledge back capability, but rather is an alphanumeric display pager which operates as shown in the time versus status diagram of FIG. 4H. Non
30 ack-back pager AB-3 receives a preamble at 340 which causes pager AB-3 to switch from a "sleep state" to a fully operational state. Subsequent to reception of the preamble at 340, non ack-back pager AB-3 receives address 1 at 350 and address 2 at 400 during time
35 interval T2. In this particular example, it is

assumed that pager AB-3 is the third pager addressed within time interval T2. That is, address 3 is the address which corresponds to pager AB-3. Pager AB-3 receives address 3 within time interval T2 at 460 as shown in FIG. 4H. Pager AB-3 decodes address 3 and determines that pager AB-3 has been paged and that a page data message will be transmitted to it shortly. Non ack-back pager AB-3 is activated to an "awake state" during time interval T4. Pager AB-3 then locates the particular AB-3 page message which is intended for it within time period T4. That is, since the predetermined relationship between the order of the page messages transmitted within time period T4 is known by pager AB-3 with respect to the order of the addresses transmitted within a time period T2, pager AB-3 locates or matches the AB-3 page data message at 470 in a manner similar to that employed by the remaining pagers within the group of M. For example, in this embodiment of the invention, since pager AB-3 was the third pager to be addressed in the group of M pagers, pager AB-3 will expect its message to likewise be third in the sequence of messages with message block 330 (FIG. 4A) or more specifically at 470 of FIG. 4H. Once message 3 is so selected, pager AB-3 displays message 3 to the pager user. In this particular embodiment, the pager user does not have the option to transmit a response back to the central station 110. Thus, non ack-back pager AB-3 is switched to a "sleep state" after the AB-3 message corresponding thereto has been received.

FIG. 4I is a time versus event diagram of the status of an unpagged ack-back pager of the population of ack-back pagers 121, 122, ...P. That is, FIG. 4I illustrates what occurs when an ack-back pager receives and decodes addresses which do not

correspond to the unique address of such unpagged pager. More specifically, the unpagged pager, which is referred to as pager AB-U, receives the preamble signal at 340 and switches from a "sleep state" to a fully operational state. Pager AB-U then proceeds to receive a group of M or 20 pager addresses at 480 during time interval T2. Pager AB-U fails to find its address within that group of M addresses. Thus, after time period T2, pager AB-U returns to the "sleep state" where it will remain where it will remained for a predetermined period of time. Alternatively, at the end of address block 480, a "go to sleep" signal can be transmitted to all pagers which did not receive a valid address to cause such pagers to enter the sleep state. FIG. 4I also represents the time versus event status of an unpagged non ack-back pager.

FIG. 5 is a flow chart of the control program which is resident in ROM 170 of central station 110. This control program controls the operation of microcomputer 150 in the manner which follows. The flow chart of FIG. 5 summarizes the operation of central station 110 which was described above in the discussion of the signalling protocol illustrated in FIG's. 4A - 4I. In accordance with block 500 of the flow chart of FIG. 5, microcomputer 150 is subjected to a power-on reset when it is turned on. That is, system variables are initialized at that point in time. For example, M, which is the number of ack-back pagers in a particular group is initialized at a predetermined number, for example 20. Additionally, a message counter variable, I, is initialized at a value of 0 in block 500. Once initialized, central station 110 is ready to accept messages from telephone callers into interface 140 or from a system

operator at keyboard 160 as per block 510. When a message for a particular pager user is input into central station 110, such message is stored in RAM 180 together with indicia of the particular pager for which such message is intended as per block 520.
5 Such message is counted by incrementing the message counter variable I by the quantity 1 as per block 530. Microcomputer 150 then makes a determination as to whether the number of messages which have been
10 collected and stored in memory is equal to M or 20 in this example. That is, as per decision block 540, microcomputer 150 determines whether message counter I equals M. If the message counter I does not equal M, which signifies that a group of M messages have
15 not yet been fully collected, then flow continues to block 545 where a determination is made whether or not a time out of TO, for example TO = 10 sec, has been exceeded. If the time out has not been
exceeded, then flow continues back to input block 510
20 to await input of yet another message. If in block 545 it determined that the time out has been exceeded, then a preamble signal is transmitted at block 550. This time out feature is provided such the microcomputer 150 will not have to wait for long
25 periods of time for a queue of M messages to be collected prior to transmitting such messages. If prior to expiration of the time out, it is determined that message counter I does equal M at block 540, then transmission of the preamble signal is commenced
30 at block 550.

Microcomputer 150 then looks up and retrieves from memory the addresses which correspond to each of the group of M pagers as seen at block 560. The addresses within such group of M pagers are
35 sequentially transmitted in a predetermined order,

for example, "first in last out" or "first in first out", as per subsequent blocks 570 through 610. More specifically, counter I is reset to 1 and now functions as an address counter as per block 570.

5 Address I is retrieved from memory as per block 580. That is, in the first time through the loop starting at 580, since $I = 1$, address 1 is retrieved from memory. That is, microcomputer 150 looks up the particular pager address which corresponds to the

10 pager for which message 1 is intended. Address 1 is then transmitted as per block 590. At decision block 600, microcomputer 150 makes a determination of whether or not all M addresses of the group of M addresses corresponding to the M messages have been

15 transmitted. This is determined by microcomputer 150 calculating whether or not I is equal to M. If address counter I is not equal to M, then all 20 addresses have not been transmitted and I is then incremented by 1 as per block 610. Flow then

20 continues back to block 580 at which the next address of the group of $M=20$ addresses is retrieved from memory. This process continues until $I = M$ at block 600 which signifies that all 20 addresses have been retrieved and sequentially transmitted as a group.

25 Flow then continues to block 620 at which reference carrier F_C is transmitted.

Counter I is then reset to $I = 1$ as per block 630. Counter I is now employed as a message counter again in the subsequent portion of the flow chart of

30 FIG. 5. Message I is retrieved from memory at block 640. The first time through the loop starting at block 640, I is equal to 1 and thus message number 1 is retrieved at block 640 the first time through such loop. Message I, or in this case message 1, is then

35 transmitted by central station 110 as per block 650.

An end of message (EOM) marker is transmitted immediately subsequent to message 1 to mark the end of such message as per block 660. A determination is then made at decision block 670 as to whether or not
5 all of the messages in the group of M messages have been retrieved from memory and transmitted. This is accomplished by microcomputer 150 making a determination as to whether I is presently equal to M. If microcomputer 150 finds that I is not yet
10 equal to M, then I is incremented by 1 as per block 680 and flow continues back to retrieve message block 640. The next message, for example message 2, is then retrieved from memory as per block 640. Message 2 is then transmitted as per block 650 and followed
15 by an end of message (EOM) marker as per block 660. This process continues until finally all M messages have been transmitted followed by respective EOM markers. It is thus seen that the M messages are transmitted as message group.

20 From the flow chart of FIG. 5, it will be observed that the group of messages transmitted as per block 640 through 680 bears a predetermined order relationship with respect to the order of the transmission of the addresses of the corresponding
25 group of M addresses as per blocks 570 through 610. That is, in this particular example address 1 was first transmitted, followed by address 2 and so forth up to address M. In this example, the transmission of the group of M messages occurs in the same order as
30 the group of addresses. That is, message 1 corresponding to the first address is first transmitted followed by message 2 which corresponds to the second address and so forth up to message M which corresponds to the M'th addressed pager. Other
35 predetermined relationship orders are possible

between the order of transmission of the messages of the group of M messages and the order of the group of M addresses as has been discussed earlier. What is important, is that such predetermined relationship
5 between the message order and the address order is known and is programmed into the ack-back pagers as is discussed later in more detail.

After it is determined that the transmission of the group of M messages is complete as per block 670,
10 flow continues to block 690 at which central station 110 pauses to permit the ack-back pager users which have received messages to key an appropriate response into their ack-back pagers for transmission subsequently back to central station 110. For
15 example, such ack-back pagers may include a keyboard or a switch that is toggled by the message recipient to signify a yes or a no. It will be appreciated that it will take significantly less time for a user to toggle one key to indicate a predetermined
20 response, for example a yes or a "canned message" (for example, I will call you back), than it would take for a user to key in a response on a keyboard or keypad situated on the pager. However, such keyboard or keypad embodiments of the ack-back pager herein
25 are considered to be within the scope of the invention in that they provide alternative ways of indicating the user's response to the ack-back pager. After pausing to permit the addressed pager users to key in their responses, central station 110
30 simultaneously receives M ack-back signals from a group of M addressed pagers as per block 700. These ack-back responses are then provided to the appropriate corresponding callers via telephone interface 140. Flow then continues back to block 510

to permit other paging messages to be input into central station 110.

FIG. 6 is a block diagram of one of ack-back pagers 121, 122...P., namely ack-back pager 121. In one embodiment of the invention, ack-back pagers 121, 122...P transmit acknowledge back signals on the same radio frequency as that on which central station 110 transmits although this is not necessarily a requirement of the system. That is, other embodiments of the invention are contemplated wherein the ack-back pagers transmit ack-back signals at frequencies other than within the spectrum of the paging channel employed by central station 110. However, in the present embodiment, circuitry is included within such ack-back pagers to enable the pagers to accurately tune to and transmit ack-back signals within the same paging channel spectrum as that employed by central station 110 for transmission of paging signals. More specifically, each of ack-back pagers 121, 122...P is capable of transmitting ack-back signals using a plurality of M different substantially orthogonal pseudorandom codes within the paging frequency channel on which central station 110 and the ack-back pagers transmit and receive. All of the ack-back pagers within a particular group of M addressed ack-back pagers simultaneously transmit acknowledge back signals back to central station 110 during a time period occurring after such group of M ack-back pagers are addressed and are sent respective messages. To permit such simultaneous transmission of ack-back signals using M different frequency substantially pseudorandom codes via code division multiplexing (CDM), it has been found that pagers 121, 122...P must be able to tune the transmitted acknowledge back signal with extreme

accuracy in frequency. The subsequently described frequency control circuitry within ack-back pager 121 permits such accuracy in frequency tuning. An example of one single conversion receiver which is
5 adaptable to accommodate the aforementioned frequency control circuitry in accordance with the present invention is the Motorola Sensar series display pager as described in the publication "Sensar" Series - Display GSC Radio Pagers, Motorola Publication No.
10 68P81038C75-A which is incorporated herein by reference.

Ack-back pager 121 includes a transmit/receive antenna 800 exhibiting an appropriate size and geometry to permit transmission and reception of
15 radio frequency signals on the radio frequency paging channel on which central station 110 transmits and receives. Antenna 800 is coupled to a common port 810A of a transmit receive switch 810. Transmit/receive switch 810 includes a receive port 810B and a
20 transmit port 810C in addition to the above mentioned antenna input port 810A. Switch 810 includes a control input 810D as shown in FIG. 6. When an appropriate control input signal is supplied to control input 810D, transmit/receive switch 810
25 couples antenna port 810A to receive port 810B to place pager 121 in the receive mode. Alternatively, pager 121 is placed in the transmit mode when an appropriate control signal is supplied to control input 810D such that transmit receive switch 810
30 couples the antenna input port 810A to transmit port 810C. These control signals are supplied to control input 810D by microcomputer 820. One microprocessor which may be employed as microcomputer 820 is the model MCC1468705G2 manufactured by Motorola, Inc.

Receive port 810B of switch 810 is coupled to the input of a radio frequency amplifier 830. It is noted that the frequency of the radio paging channel on which central station 110 transmits is defined to be F_{RX} , for example, 150 MHz. Thus, the radio frequency paging signals which reach ack-back pager 121 and which are provided to amplifier 830 exhibits a frequency of F_{RX} or 150 MHz. Amplifier 830 amplifies the radio paging signals from central paging station 110 and provides such amplified signals to the input of a bandpass filter 840. Filter 840 is typically of the preselector type which filters off any undesired signals adjacent the paging channel frequency.

The output of filter 840 is coupled to an input 850A of a two input mixer 850. Mixer 850 includes inputs 850A and 850B and an output 850C. A local oscillator 860 which oscillates at a frequency of F_{LO} is coupled via an amplifier 870 to mixer input 850B. Mixer 850 down-converts the filtered RF paging signal at frequency F_{RX} thereto by mixing such signal F_{LO} signal. In this manner, the down converted RF signal generated at the output 850C of mixer 850 is at an intermediate frequency of $F_{RX}-F_{LO}$ which is defined to equal F_C .

Mixer output 850C is coupled to the input of an intermediate frequency (IF) amplifier 890 which amplifies the down-converted RF paging signals. The output of IF amplifier 890 is coupled to a count input 820A of microcomputer 820 to determine the down-converted reference carrier frequency F_C as later described. The output of IF amplifier 890 is also coupled to the input a demodulator 900 which demodulates the down-converted RF paging signals provided thereto. That is, demodulator 900 separates

the preamble, address, and message signals from the carrier wave on which they were transmitted by central station 110. The data signals thus resulting are provided to microcomputer input 820B via a

5 connection to demodulator 900 as shown in FIG. 6. Such data signals include preamble, address, and message signals. Microcomputer 820 of pager 121 decodes the address signals provided at data input 820B and compares the incoming decoded page addresses

10 with the predetermined unique address of such pager 121 which is stored in a code memory 910. Code memory 910 is typically an electronically erasable programmable read only memory (EEPROM) such that unique pager address codes are easily assigned and

15 programmed into each of ack-back pagers 121, 122...P. As seen in FIG. 6, memory 910 is coupled via a buss to a memory port 820C of microcomputer 820. When microcomputer 820 determines that one of the addresses in a received group of M pager addresses

20 corresponds to the unique address of such pager 121, then microcomputer 820 decodes the following group of M messages. Microcomputer 820 selects which of such messages is intended for pager 121.

In a known fashion, microcomputer 820 generates

25 appropriate output signals which are supplied via linear support module 920 to audio module 930 and speaker 940 to alert the pager user that a message has been received. The selected message is stored in a random access memory (RAM) 950 which is coupled via

30 a bus to microcomputer memory port 820D. A liquid crystal display module 960 is coupled to the display output 820E of microcomputer 820 such that the selected message received by pager 121 can be displayed for viewing by the pager user.

35 Alternatively, the pager user can recall the page

message from memory 950 subsequent to the alert signal for viewing later at a more convenient time. A clock circuit 970 is coupled to a clock input 820F of microcomputer 820. Clock 970 provides
5 microcomputer 820 with a reference time base.

A user reply input device 980 is coupled to a data input port 820G of microcomputer 820 as shown in FIG. 6. In one embodiment of the invention, the user reply input device 980 is a four position switch, the
10 positions of which are respectively designated as choices A, B, C, and D. By preagreement between the pager user and the pager caller, each of choices A, B, C, and D is agreed to have a predetermined meaning. For example, choice A when selected by the
15 pager user could be a "Yes" response to the caller's message. Choice B could be "No" response. Choice C is a "Maybe" response and Choice D is a "Cannot Reply Now" response. Those skilled in the art readily appreciate that the output of such a four position
20 switch when used in input device 980 is readily converted to a digital signal which is supplied to data input port 820G for processing by microcomputer 820. Alternatively, a 2 position or YES/NO switch could be employed in user input device 980.

25 It is noted that user reply input device 980 is not limited to the multi-position switch which was discussed above. Rather, other input devices, for example, a keyboard or other key entry devices may be employed as user input device 980 in other
30 embodiments of the invention to generate reply data.

The reply data is then transmitted back to central station 110 by pager 121 during acknowledge back reply field 390 as shown in the acknowledge back protocol shown in FIG. 4E. Each pager of the group
35 of M ack-back pagers which were addressed now respond

back simultaneously as a group during the appropriate
acknowledge back field. Each of the M pagers of the
group responds using a different one of M
pseudorandom codes. In one embodiment of the
5 invention wherein $M=20$, a pseudorandom code of length
127 is used. Such a code is generated as described
by John G. Proakis in Digital Communications
published by McGraw Hill Book Company, 1983, ISBN 0-
07-050927-1, pages 256-258, which is incorporated
10 herein by reference. In the Proakis arrangement,
such a code is generated as the output of seven shift
registers preloaded with the binary digits 1000000
and where registers 1 and 7 are combined by an
exclusive OR operation and fed back to the first
15 register on the next clock cycle. Thus, a
pseudorandom sequence of 127 bits is repeatedly
generated. Those skilled in the coding arts will
appreciate that other substantially orthogonal
pseudorandom codes may be generated and used as well
20 consistent with practice of the invention. The
particular code shown in FIG. 7 exhibits the property
that the code is substantially orthogonal to the same
code shifted by any number other than a multiple of
127 bits. In this embodiment of the invention, the
25 127 bit code is segmented into twenty starting
positions as shown in FIG. 7. A respective starting
position commences at every sixth bit. Thus the code
sequence beginning with bit 1 or code number 1 in the
table of FIG. 7 is orthogonal to the code sequence
30 called code 2 beginning with bit number 7 of the 127
bit pseudorandom code sequence and so forth onto code
20 which is the sequence of 127 bits beginning with
bit number 115. The code repeats from bit 1 after
bit 127.

More specifically, code 1 for pager AB-1 starts at the designated starting position in the table of FIG. 7, namely 100000 and continues with 011111, 110101 ... 010000. Code 2 for pager AB-2 starts with
5 the designated starting position 011111 and continues with 110101, 010011 ... 110000, and so forth for the subsequent codes 3...20.

One of the M pseudorandom code sequences is thus understood to be the repeating sequence of 127 bits
10 of Table of FIG. 7 where each of the M codes exhibits a unique starting point. The code starting point is designated by the pseudorandom code number (PRC. No.). The pseudorandom code sequence is sent at an 8500 bit/sec rate and is modulated by an
15 exclusive OR operation with the acknowledge back reply data at a 100 bit/sec data rate in microcomputer 820. The 8500 bit/sec pseudorandom coded data is sent by microcomputer 820 on port 820I to the data input port 1020B of phase modulator 1020.
20 A code rate of 8500 bits/sec is sufficient to spread the modulation over approximately a 15 KHz bandwidth and results in 85 pseudorandom bits per data bit which is sufficient to render the M codes to be substantially orthogonal to each other.

Each of the group of M pagers designated AB-1, AB-2 ... AB- 20, and in fact all of the pagers of the population of P acknowledge back pagers are capable of acknowledging back using any one of the M
25 different pseudorandom codes. That is, the control program stored within memory 910 is capable of
30 directing microcomputer 820 to transmit acknowledge back signals coded by a selected one of the M or 20 different pseudorandom codes.

In more detail, the output of amplifier 870 is
35 coupled to the input of an amplifier 990. Thus, an

amplified replica of the F_{LO} signal from local oscillator 860 appears at the output of amplifier 990. The output of amplifier 990 is coupled to input 1000A of a mixer 1000 having inputs 1000A and 1000B.

5 In this manner, the amplified local oscillator signal is provided to mixer input 1000A. The output of amplifier 990 is also coupled to the input of a divide by N circuit 1010. Divide by N circuit 1010 is a programmable prescaler which digitally divides

10 the F_{LO} signal by an integer value N. Such divider circuits are well known to those skilled in the art and are readily available from many commercial sources. The divider circuit selected for divider circuit 1010 exhibits an allowable range of

15 programmable dividers, N, between 2048 and 8192 and can accommodate an input frequency near 150 MHz for this particular embodiment of the invention. Divide by N circuit 1010 is coupled to an input 820H of microcomputer 820 such that the value selected for N

20 is provided to divider 1010. The frequency of the signal which is generated at the output of divider circuit 110 is equal to F_{LO}/N . The output of divider circuit 1010 is coupled to an input 1020A of a two input exclusive OR gate 1020. Exclusive OR gate 1020

25 is employed as a phase modulator and includes inputs 1020A and 1020B. The remaining input 1020B of exclusive OR gate 1020 is coupled to the reply data output 820I of microcomputer 820. In this manner, reply data which includes indicia of the acknowledge

30 back response provided by the pager user at user reply input 980 is provided to exclusive OR gate 1020 for phase modulation onto to F_{LO}/N signal provided at input 1020A. A phase modulated ack-back signal is thus generated at the output of exclusive OR gate

35 1020.

The output of exclusive OR gate 1020 is coupled to input 1000B of mixer 1000. In this manner the phase modulated ack-back signal exhibiting a frequency of F_{LO}/N is mixed with the F_{LO} signal such that the ack-back transmit frequency of F_{TX} at the output of mixer 1000 is equal to F_{LO} plus F_{LO}/N . The output of mixer 1000 is coupled via a bandpass filter 1030 to a power amplifier 1040. Bandpass filter 1030 filters any undesired signal components from the F_{TX} signal. Amplifier 1040 amplifies the filtered F_{TX} signal up to a signal level sufficient for transmission back to central station 110. The output of amplifier 1040 is coupled to the transmit input 810C of transmit/receive switch 810. It is noted that there is a predetermined relationship between the particular pseudorandom code with which each of ack-back pagers AB-1 - AB-20 responds to either the order of each pager's particular address within the group of M pagers or the order of each pager's particular message within the group of M pagers. From the earlier discussion, it will be recalled that the order of the messages within a group of M messages bears a predetermined relationship to the order in which the addresses for such messages were transmitted in the corresponding address group. The relationship between the selection of pseudorandom code for ack-back transmission and the order of transmission of the M addresses or M messages is established to enable microcomputer 150 in central station 110 to determine which ack-back signal code transmission corresponds to which acknowledge back pager address of the group of M pagers.

For example, assuming that pager AB-1 in the pseudorandom code look-up table of FIG. 7 is the first ack-back pager of the group of M pagers to be

addressed or receive a message, then, ack-back pager AB-1 responds back on a with a pseudorandom code designated pseudorandom codes 1 (or PRC No. 1) which corresponds to the code starting point noted in Table 1. Assuming that pager AB-2 in the table of FIG. 7 is the second pager of the group of M pagers which is addressed or sent a message, then, pager AB-2 acknowledges back with the code starting at pseudorandom code positions as shown in the table of FIG. 7. To continue this example, assuming that pager AB-20 is the twentieth pager of the group of M pagers to be addressed or receive a message, then pager AB-20 acknowledges back with the code starting at position 20 (PRC No. 20) as shown in FIG. 7. Although each of pagers AB-1, AB-2 ... AB-20 responds back with a different respective pseudorandom code 1-20 noted in FIG. 7, all of such pagers respond back simultaneously at the same frequency in a common time slot or field as already described.

It is noted that other predetermined relationships between the ack-back code order and the order in which the addresses or messages were transmitted to the group of M pagers may be employed. That is, although in the example above, the order of the M addresses (or M messages) and the corresponding order of the M codes are both ascending, in another embodiment of the invention in which the order of the addresses of the group of M pagers AB-1 ... AB-20 is the same as the prior example (ascending), the order of the acknowledge back codes is reversed as compared to the prior example (descending). That is, pager AB-1 responds back with code 20; pager AB-2 responds back on code 19 ... and pager AB-20 respond back on code 1.

Also, as mentioned briefly earlier in this document, alternatively in another embodiment of the invention, the relationship between the order in which pager addresses or messages were received by the group of M pagers and the order of assignment of pseudorandom codes for ack-back to such M pagers can be arbitrary. What is important is that a predetermined relationship exists between the order of assignment of codes and the order in which the pager addresses or messages arrive at the group of M pagers. Again, this predetermined relationship is programmed into memory 170 of microcomputer 150 in central station 110 such that microcomputer 150 can determine which code is being used by each of the pagers AB-1, AB-2 ... AB-20 as they acknowledge back.

An example is now presented showing how one of the AB-1, AB-2 ... AB-20 pagers selects a pseudorandom code on which to respond and generates an acknowledge back signal using that code. For purposes of this example, the third pager to be addressed or receive a message in the group of M pagers, that is pager AB-3, will be discussed. In this example, unlike the example of FIG. 4H, pager AB-3 is an acknowledge back pager. After reading the message which is supplied to the display 960 of pager AB-3 (such as pager 121 of FIG. 6), the pager AB-3 user indicates a reply at input device 980 as already discussed. The control program in memory 910 of pager AB-3 causes microcomputer 820 therein to recognize that AB-3 is the third pager of the group M = 20 pagers to be addressed. A pseudorandom code and code look-up table is stored in memory 910. The code look up table includes the appropriate starting point for each of the 20 different pseudorandom codes as shown in FIG. 7. As mentioned, microcomputer 820 of

pager AB-3 determines that it has received the third address or third message in the respective address or message group sequences. Using this information, microcomputer 820 fetches from memory the particular code from the code look up table in memory 910 which
5 corresponds to the third code or code 3.

In the circuit arrangement of FIG. 6, the ack-back frequency F_{TX} equals F_{LO} plus F_{LO}/N . F_{LO}/N varies with the amounts of error between the F_{LO} local oscillator frequency and the F_{RX} reference
10 frequency. It is noted that the F_{RX} paging channel center frequency is stored as a reference number in memory 910. In the above equation defining F_{TX} , N equals $(F_{RX} - F_C)/F_C$. Microcomputer 820 performs the calculation of N and provides the value of N to
15 divider circuit 1010. More specifically, to calculate the value of N , microcomputer 820 determines the frequency of the down-converted reference carrier signal, F_C , by counting the frequency of such signal at microcomputer input 820A during reference carrier transmission time T_3 . Microcomputer 820 retrieves the F_{RX} reference center
20 frequency value from memory 910. With all the variables which define the divisor N thus being known, microcomputer 820 calculates the value of N and supplies the same to divider circuit 1010 as already described. The signal generated at the output of divider circuit 1010 thus exhibits a
25 frequency of F_{LO}/N . The F_{LO}/N signal is mixed with the F_{LO} signal at mixer 1000 to generate the F_{TX} transmit frequency of $F_{LO} + F_{LO}/N$. It is appreciated that by replacing N with the expression for N , we get
30 $F_{TX} = F_{LO} + F_{LO}/N = F_{LO} + F_{LO}(F_C)/(F_{RX} - F_C)$. By definition $F_{LO} = F_{RX} - F_C$ since both F_C and F_{LO} contain exactly the opposite frequency error. It follows
35

that the sum $F_{LO}+F_C$ cancels the frequency error. It is noted that $F_{TX} = F_{LO}+F_C = F_{RX}$ exactly.

The present circuit arrangement uses the local oscillator frequency F_{LO} as a reference for
5 generation of the ack-back transmit frequency F_{TX} . It is noted that the circuit arrangement described above, corrects for differences in the frequency of the local oscillator F_{LO} .

Although, a single conversion embodiment of
10 acknowledge back pager 121 is shown in FIG. 6 and described above, those skilled in the art will appreciate that double and other multiple conversion embodiments of the pager are readily adapted from this invention and are intended to be within its
15 scope.

Each of pagers 121,122...P includes a threshold detector 1050 coupled between the output of amplifier 890 and input 820J of microcomputer 820. Threshold detector 1050 provides input 820J a logical 0 when
20 the down-converted carrier signal at F_C exhibits a voltage level less than a predetermined threshold level. However, when the signal voltage level of the F_C carrier signal is equal to or greater than such selected predetermined voltage level, then threshold
25 detector 1050 provides a logical 1 to microcomputer input 820J. The threshold is set, for example, so that a signal at the receiver input which is 40 dB above minimum usable receiver sensitivity will trigger threshold detector 1050. Microcomputer 820
30 includes a power control output 820K which is coupled to a power level control input 1040A of variable output power amplifier 1040. Amplifier 1040 is of the type which can assume different power output levels depending upon the value of the signal
35 provided to 1040A. For example, in this particular

embodiment, when a logical 0 is provided to input 1040A, amplifier 1040 operates or transmits at full power, for example at approximately 1.5 watts output. However, when a logical 1 is provided to input 1040A, amplifier 1040 throttles back or reduces power to a second lower power output level which is approximately 40 dB less than the full power output level. In summary, in this embodiment of the invention, when a logical 0 is provided by threshold detector 1050 to microcomputer input 820J indicating that a relatively low level signal is being received, then microcomputer 820 generates a logical 0 at its output 820K. This causes amplifier 1040 to amplify at the first or full output power. However, when threshold detector 1050 provides a logical 1 to microcomputer input 820J, indicating that a relatively high level signal is being received, microcomputer 820 then generates a logical 1 at output 820K. This in turn causes amplifier 1040 to throttle back to the second lower output power level. The above described variable output power level circuit arrangement aids in avoiding the situation when any one of the group of M pagers AB-1...AB-20 generates such a strong ack-back signal at central station 110 that such signal exceeds the dynamic range of the receiver of station 110 and masks the ack-back signals from the other pagers of the group of M.

Although in this particular embodiment of the invention, a two power level amplifier 1040 is employed in conjunction with a single level threshold detector 1050, the invention may also be practiced using threshold detectors with more than one threshold and variable output power amplifiers with more than two selectable output powers. For example,

in an alternative embodiment of the invention, threshold detector 1050 is a three range threshold detector which determines if the F_c signal exhibits a low, medium or high signal level. Such a threshold
5 detector conveniently employs first and second thresholds. That is, when threshold detector 1050 determines that the received signal level at the pager is within a first predetermined low signal level range (less than the first threshold), then
10 microcomputer 820 causes a three output power level amplifier, employed as amplifier 1040, to amplify at a high output first power level. When the three range detector 1050 detects that the received signal level is within a medium signal level range (between
15 the first and second thresholds), then microcomputer 820 would causes amplifier 1040 to amplify at a medium output second power level. When detector 1050 determines that the received signal level is within a third high level range (above the second threshold
20 level), then microcomputer 820 causes amplifier 1040 to fully throttle back to a third and lowest power output level. Thus, a power control circuit is provided in which the transmitted output power of the ack-back pager varies inversely with the RF signal
25 level of the paging signals it receives from central station 110.

Microcomputer 820 is programmed to generate a logical 1 at port 820L during the period of time at which pager 121 is to transmit an acknowledge back
30 signal back to central station 110, for example, ack-back time period 390 as shown in FIG. 4E. During all other periods of time for which pager 121 should be in the receive mode, microcomputer 820 is programmed to generate a logical 0 at port 820L. When a logical
35 1 is generated at output 820L, indicating transmit

mode, transmit/receive switch 810 connects antenna port 810A to port 810C thus connecting the transmit amplifier 1040 to antenna 800. However, when a logical 0 is provided to microcomputer port 820L,
5 transmit/receive switch 810 couples antenna port 810A to port 810B and receiver amplifier 830.

FIG. 8 is a flow chart of the control program stored in memory 910 which controls the operation of microcomputer 820 and pager 121. A power-on-reset
10 step is shown in block 1100. Program variables are initialized at this time. The receiver portion of pager 121 is turned on and becomes synchronized with respect to the paging signals transmitted on the paging channel by central station 110. After
15 becoming initially synchronized, pager 121 goes into a "sleep mode" or battery saving mode as described earlier. When pager 121 receives a preamble signal, as in block 1110, pager 121 wakes up as per block 1120. An address count variable, ADRCOUNT, is then
20 initialized with a value of 0 as per block 1130. A variable ADRMAX which represents the maximum number of ack-back pagers in an ack-back group is set to have a value of M as per block 1130. Pager 121 listens to each of the addresses within a group of M
25 addresses to determine if its particular address is received as per block 1140. For example, at block 1140, the first address of a group of M addresses is checked to determine if it is the valid address for the particular pager 121. If the first address is
30 not the address of pager 121, then the ADRCOUNT variable is incremented by 1 to count the number of pager addresses already received as per block 1150. A determination is then made as to whether all of the addresses of the group of M addresses have been
35 processed, block 1160. If the variable ADRCOUNT is

equal to M, then the address of the particular pager 121 has not been received and such pager 121 reenters the battery saver mode as per block 1170 after which pager 121 again powers down and looks to determine if a preamble signal is received. If however in block 5 1160 ADRCOUNT is not equal to M, that is less than M signifying that all of the M addresses of a group of M addresses have not been received as in the present example with respect to the first address of such 10 group, then flow continues back to block 1140 where pager 121 checks the next address in the group of M addresses for validity. If any address within the group of M addresses is determined to be the address for the particular pager 121, then flow continues 15 from block 1140 to block 1180 at which the variable ADRCOUNT is incremented by 1 such that ADRCOUNT is a number which represents the order of the valid address within the sequencing or group of M addresses.

20 After the group of M addresses is received by pager 121, pager 121 receives and determines the frequency of the down-converted reference carrier F_C as per block 1190. The signal strength of the carrier F_C is then determined by micro processor 820 25 as per block 1200.

In the following steps, the particular message within the group of M messages which is intended for a particular pager within the group of M addressed pagers is matched with such pager and displayed 30 thereon. More particularly, prior to commencing to count the number of messages within the group of M messages as such messages are received, a message count variable MSGCOUNT is initialized at a value of 0 as per block 1210. The receiving of the individual 35 messages of the group of M messages commences as per

block 1220 at which the next message of such group is received. Initially, the first message of the group of M messages is the "next message" received. Upon reception of a message, the MSGCOUNT variable is

5 incremented by 1 to count the number of messages that have been received as per block 1230. A determination is then made as to whether MSGCOUNT equals ADRCOUNT at block 1240. If it is determined that MSGCOUNT does not equal ADRCOUNT, then more

10 messages remain to be received in the group of M messages and flow continues back to block 1220, at which the next message is received. In this example, wherein the first message was received the first time around the loop formed between block 1220 and 1240,

15 the second message is received the second time around such loop and the message counter MSGCOUNT is incremented at 1230 accordingly. When a determination is made that MSGCOUNT equals ADRCOUNT then, the current message is displayed at block 1250.

20 In this manner, the particular message which was intended for a pager within the group of M pagers is displayed by matching the order of the occurrence of such message in the group of M messages with respect to the order of the corresponding address within the

25 group of M addresses.

Ack-back data is supplied to microcomputer 820 by the pager user as per block 1260. The ack-back pager waits as per block 1270 for an ack-back field (time interval) before responding back to the central

30 station 100 with the ack-back data provided by the pager user. It was discussed earlier that M different pseudorandom codes are available in the pager of the invention for transmission of ack-back signals. Each ack-back pager within a group of M

35 addressed pagers responds back to the central station

110 on a different respective pseudorandom code based on the value of the ADRCOUNT variable determined above for such pager as per block 1280. For example, in one embodiment of the invention, if a particular pager within the group of M pagers is the fifth pager of the group to be addressed, then such pager has an ADRCOUNT value of 5. As per the above discussion, the fifth message in the group of M messages corresponds to the fifth pager addressed and is appropriately provided to the display of such fifth pager for viewing by the pager user. In this particular pager wherein ADRCOUNT equals 5, code number 5 is selected from the table of FIG. 7 for use by such pager for transmitting its ack-back signal. That is, the value of ADRCOUNT determines the particular pseudorandom code which is selected for ack-back. Since in this particular example code 5 is selected, microcomputer 820 accesses the code chart of the table of FIG. 7 and looks up the pseudorandom code starting point corresponding to code number 5 as per block 1290. Microcomputer 820 then looks up the value of the pager channel center frequency F_{RX} in memory as per block 1300. The value of F_C , the down-converted carrier frequency, is then retrieved from memory or is otherwise acquired as per block 1310. Using the retrieved values of F_{RX} and F_C , the value of the divisor N is determined according to the equation $N = (F_{RX} - F_C)/(F_C)$ as per block 1320. Divider 1110 in FIG. 6 is then set to have a N value as determined above in order to drive the frequency of the ack-back pager to exactly 150 MHz as set in block 1330. In this example, $F_{RX} = 150$ MHz, $F_C = 0.0350$ MHz, and the nearest integer value for N is $N = 4285$. The resulting ack back transmit frequency F_{TX} is therefore 149.9999977 MHz which is 2.3 Hz from

the desired transmitter frequency and well within the 30 Hz frequency tolerance required in this particular embodiment of the invention.

A determination is then made by microcomputer
5 820 as to whether the signal level of the F_C
reference carrier is greater than the aforementioned
predetermined threshold level. If the F_C signal
level is greater than a predetermined threshold level
as determined at block 1340, then the transmitter
10 circuits of pager 121 are turned on, as at block
1350. The ack-back data is then transmitted back to
central station 110 at a low power level using the
already selected code via code division multiplexing
as per block 1360. After transmission of the ack-
15 back data, the transmitter circuits are turned off at
block 1370 and the battery saver mode is reentered as
at block 1170. If, however, it is determined at
block 1340 that the F_C carrier reference signal does
not exhibit a signal level greater than the
20 predetermined threshold, then the transmitter
circuits of pager 121 are turned on at block 1390 and
the ack-back data is transmitted back to central
station 110 at a high power level using the selected
pseudorandom code via code division multiplexing as
25 per block 1400. After such transmission of the ack-
back data, the transmitter circuits are turned off at
block 1370 and the battery saver mode is reentered at
block 1170.

From the above description, it is clear that the
30 invention involves a method of radio paging which is
employed in a radio paging system including a paging
terminal or central station for transmitting address
and message signals to a plurality of remotely
located radio pagers. Each of such pagers has an
35 address corresponding thereto. The method of radio

paging includes the step of sequentially transmitting a batch of M pager addresses during a first time period, wherein M is the number of pager addresses in said batch. The method further includes the step of
5 the batch of pagers addressed in the above step transmitting respective acknowledge back signals simultaneously in a second time period subsequent to said first time period, each of such batch of pagers transmitting a different substantially orthogonal
10 pseudorandom code which is assigned to each respective pager.

In summary, the foregoing describes an apparatus and method for radio paging which permits the pager user to respond to the pager caller. Each radio pager is capable of responding back to the paging terminal and the caller. Moreover, a group of M addressed ack-back pagers are capable of simultaneously transmitting acknowledge back signals on a selected frequency, each pager transmitting a respective acknowledge back signal using a different substantially orthogonal pseudorandom code.

While only certain preferred features of the invention have been shown by way of illustration, many modifications and changes will occur to those skilled in the art. It is, therefore, to be understood that the present claims are intended to cover all such modifications and changes which fall within the true spirit of the invention.

CLAIMS

1. An acknowledge back pager having a unique address associated therewith, the pager having

5 receiver means for receiving paging signals from a central station, the paging signals including a batch of M pager addresses transmitted in a sequential order during a first time period, wherein M is the number of pager addresses in the batch,

10 decoding means coupled to said receiver, for detecting the presence of the pager's address within the batch of M addresses, and

address order determining means coupled to said decoder, for determining the order of the pager's address within the batch of M addresses, CHARACTERIZED IN THAT:

15 the pager further includes pseudorandom code transmitting means for transmitting an acknowledge back signal at a selected frequency, the acknowledge back signal including a selected one of a plurality of M substantially
20 orthogonal pseudorandom codes, the selected one of the codes exhibiting a predetermined relationship to the order of the address of the pager within the batch of M addresses.

2. The acknowledge back pager of claim 1 wherein the batch of addresses are designated 1, 2, ... M based on the order in which the addresses of the batch of addresses are transmitted and wherein the plurality of pseudorandom codes are designated 1, 2, ... M, said pseudorandom code transmitting circuit assigning itself a respective pseudorandom code based on the same order as that in which the address corresponding to such pager was transmitted by the central station.

10

3. The acknowledge back pager of claim 1 wherein the batch of addresses are designated 1, 2, ... M based on the order in which the addresses of the batch of addresses are transmitted and wherein the plurality of pseudorandom codes are designated 1, 2, ... M, said pseudorandom code transmitting circuit assigning itself a respective pseudorandom code based on the reverse of the order as that in which the address corresponding to such pager was transmitted by the central station.

20

4. The acknowledge back pager of claim 1 including an alert means for providing an alert to indicate to a user of an addressed one of the M pagers that the pager has been addressed.

25

5. The acknowledge back pager of claim 1 including a response indicating means wherein a user of the pager indicates a response to the pager for transmission in the acknowledge back signal.

6. The acknowledge back pager of claim 1 including a memory means for storing a look up table of the M pseudorandom codes.

5

7. The acknowledge back pager of claim 1 including means for receiving and displaying message signals transmitted by said central station in a second time period subsequent time period.

FIG. 1

10

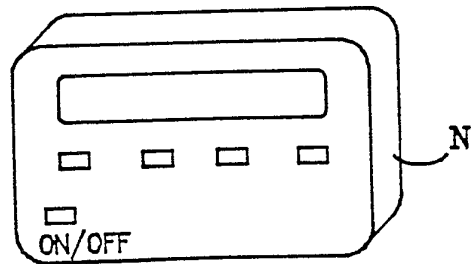
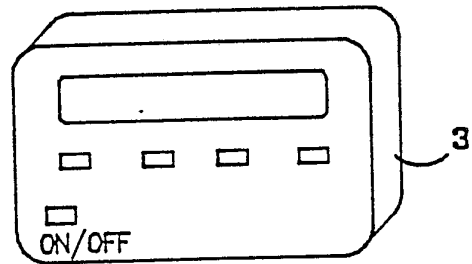
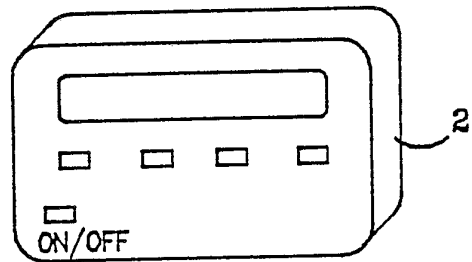
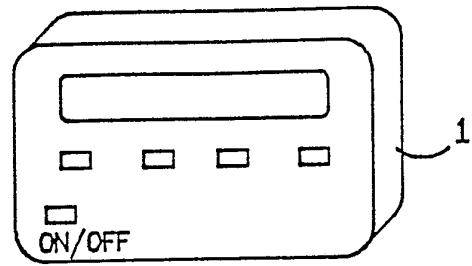

20

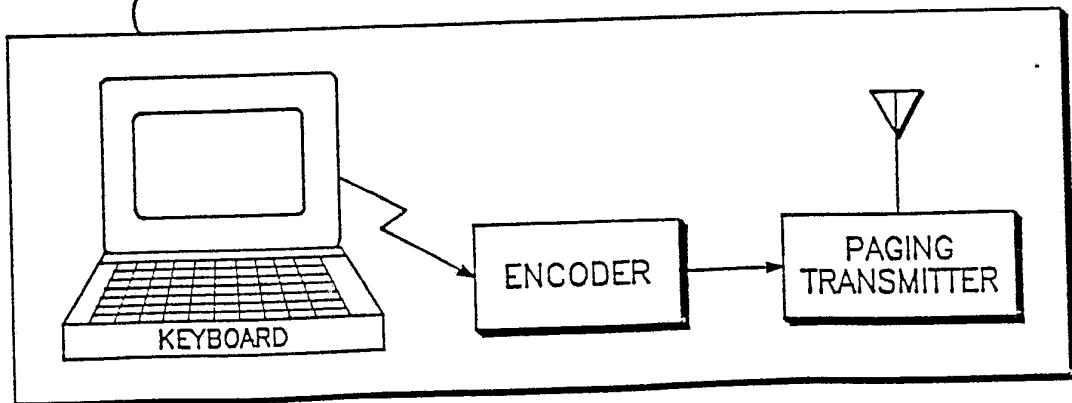

FIG. 2
100

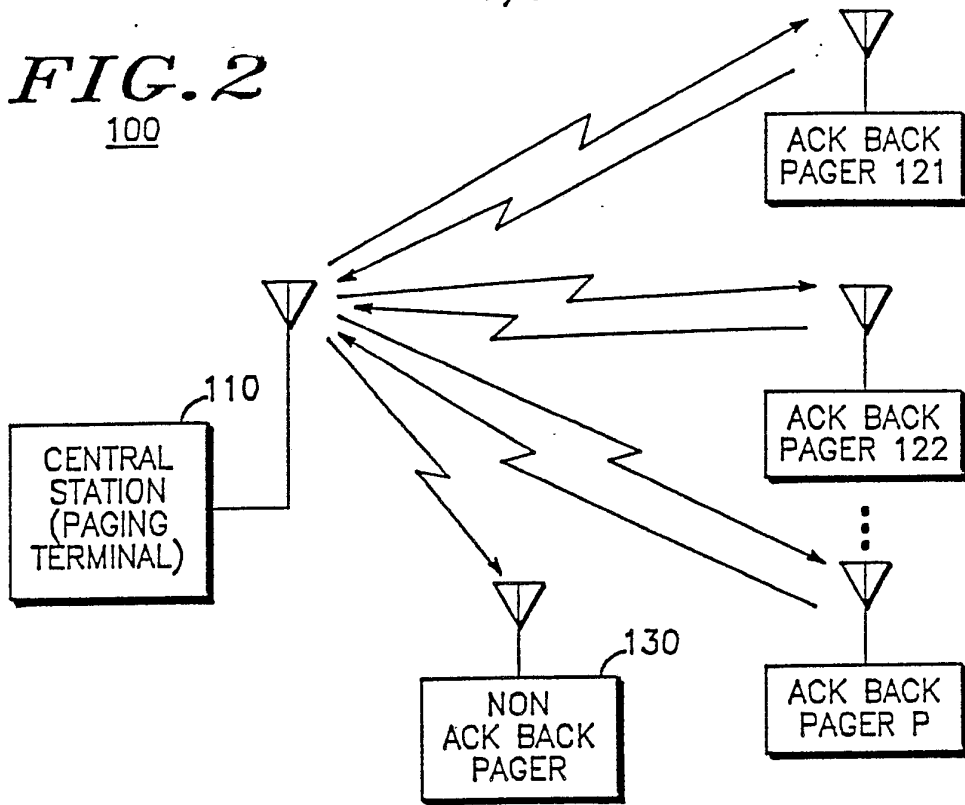
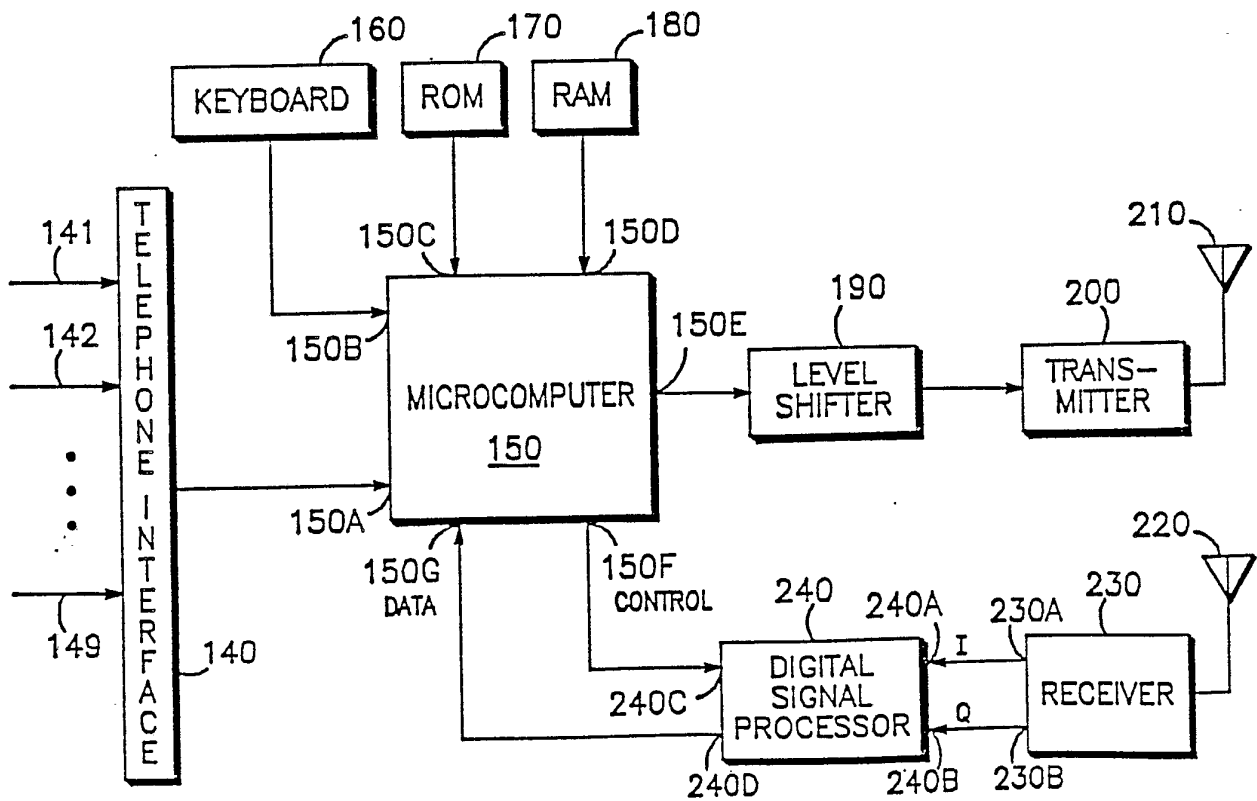
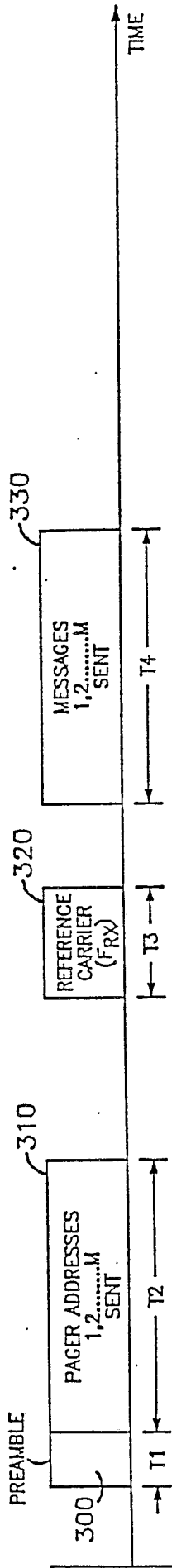

FIG. 3
110





CENTRAL STATION TRANSMITTER

FIG. 4A

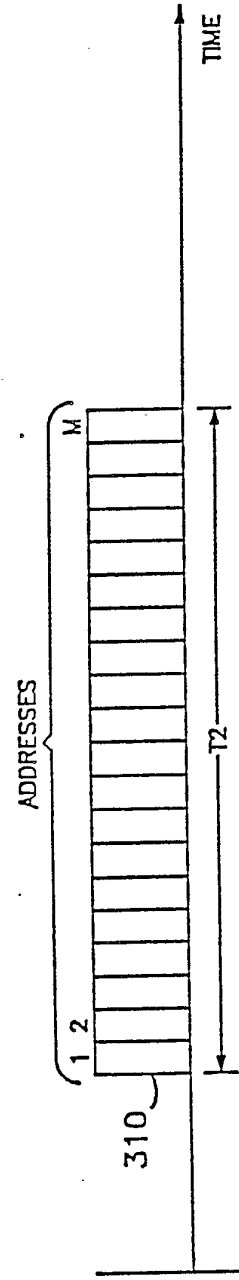

FIG. 4B

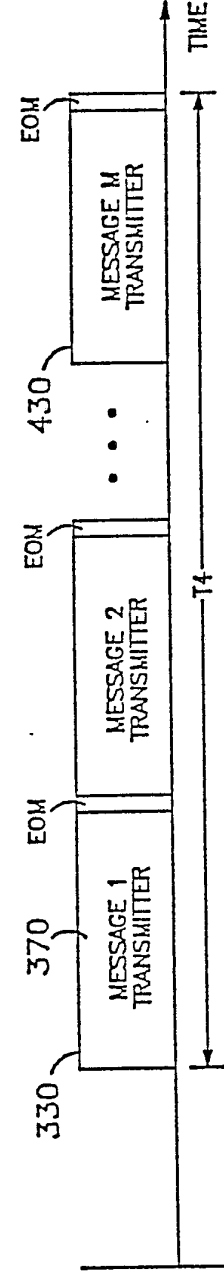
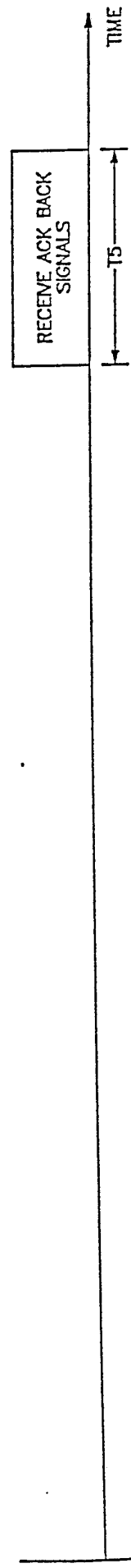
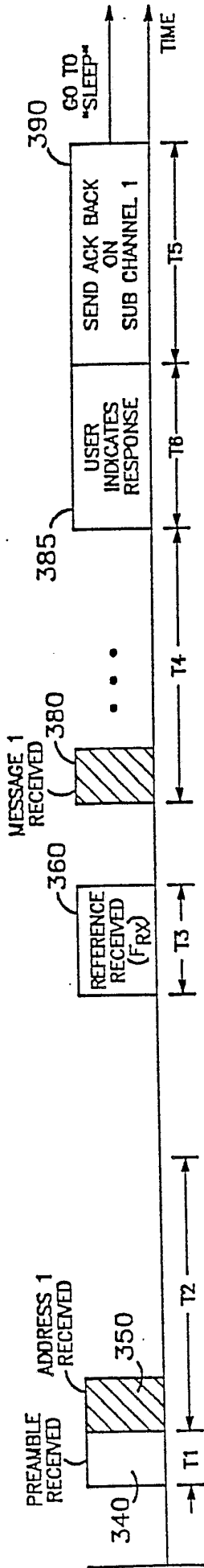

FIG. 4C



CENTRAL STATION RECEIVER

FIG. 4D



AB-1

FIG. 4E

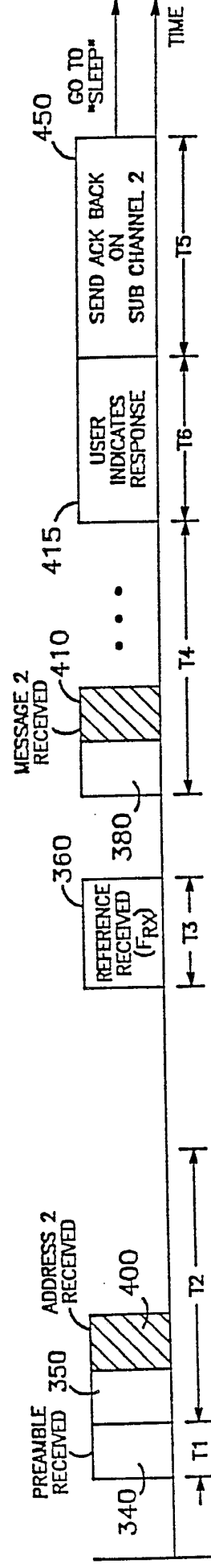

AB-2

FIG. 4F

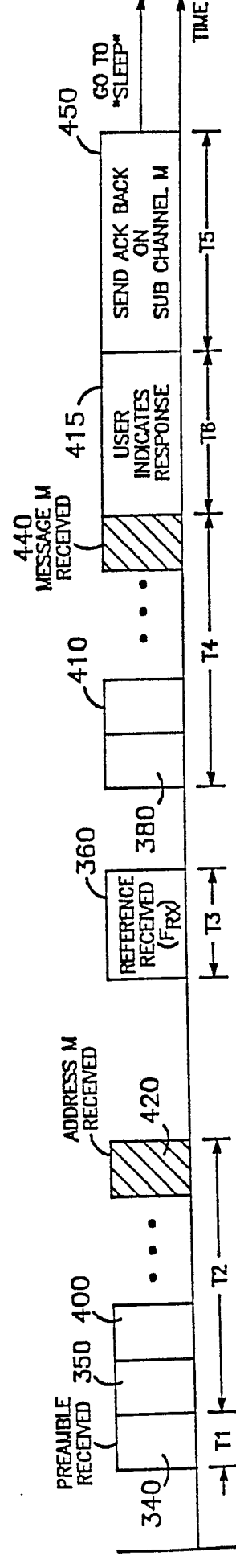

AB-M

FIG. 4G

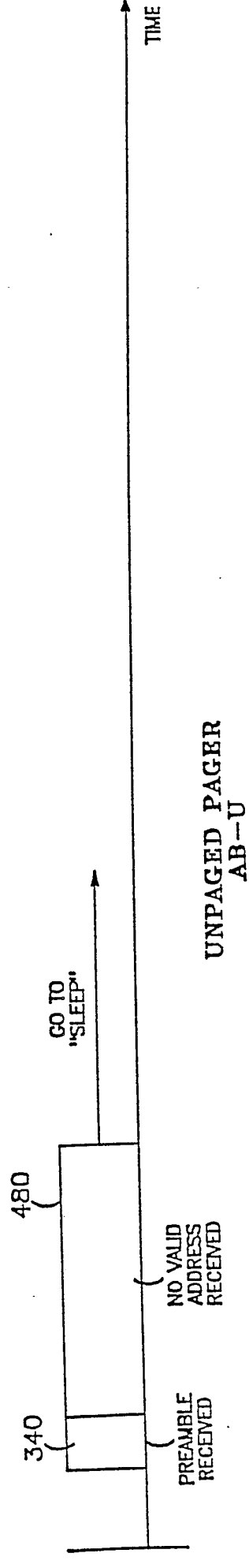
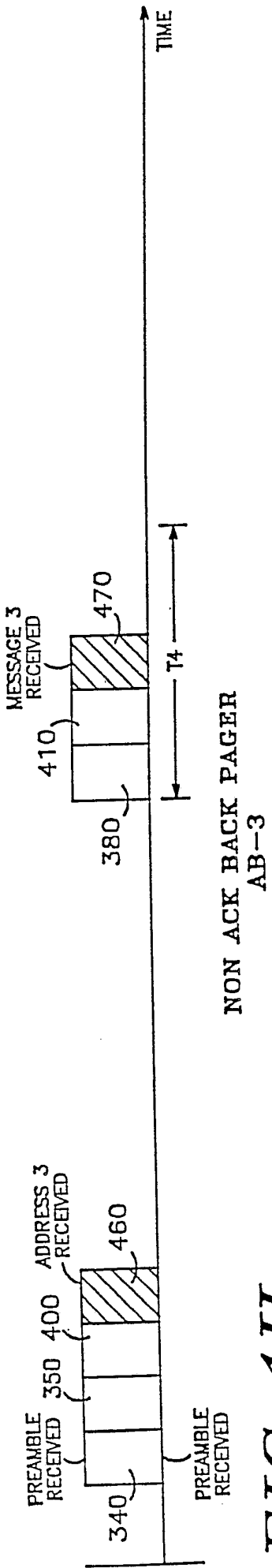
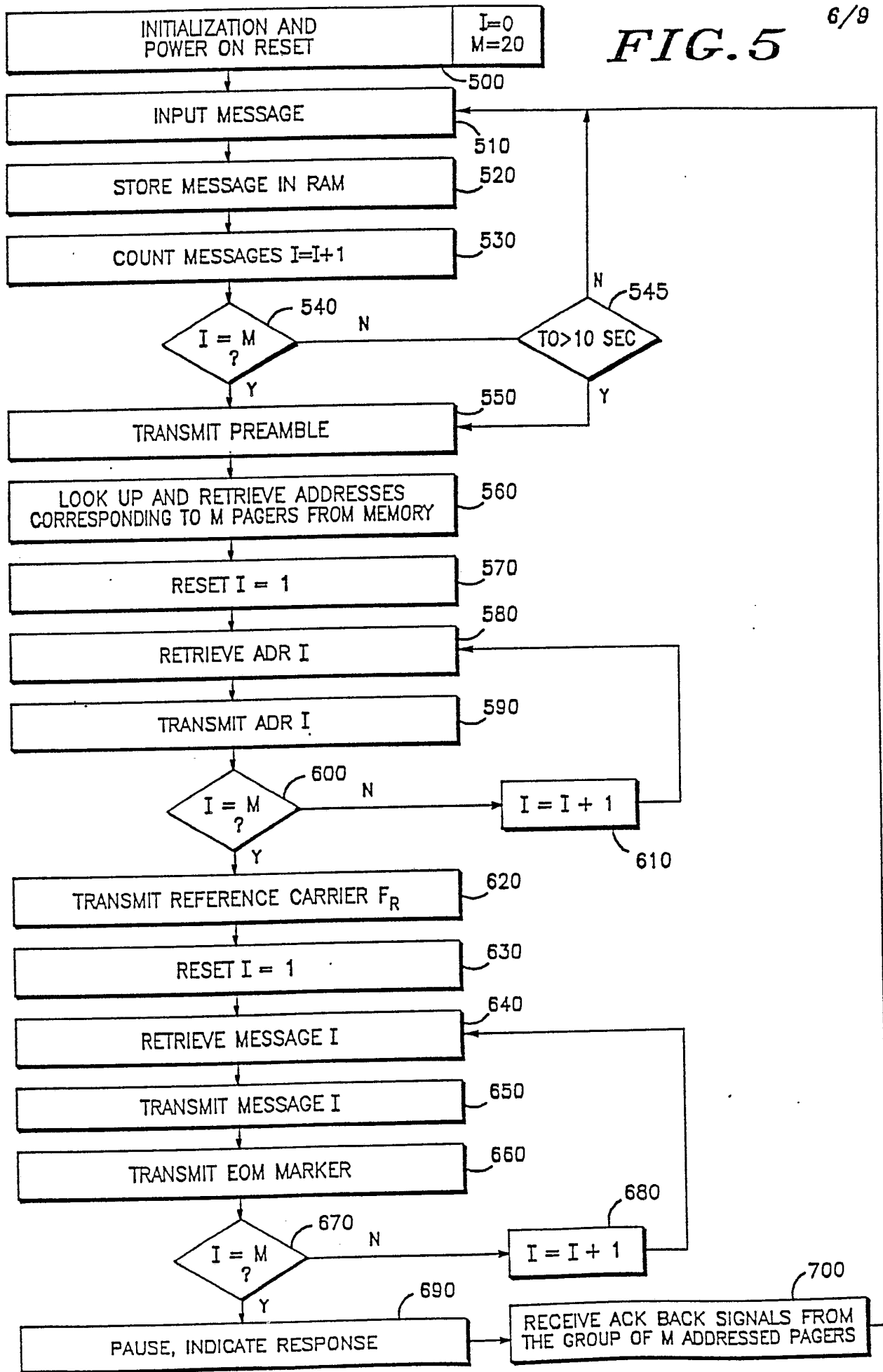
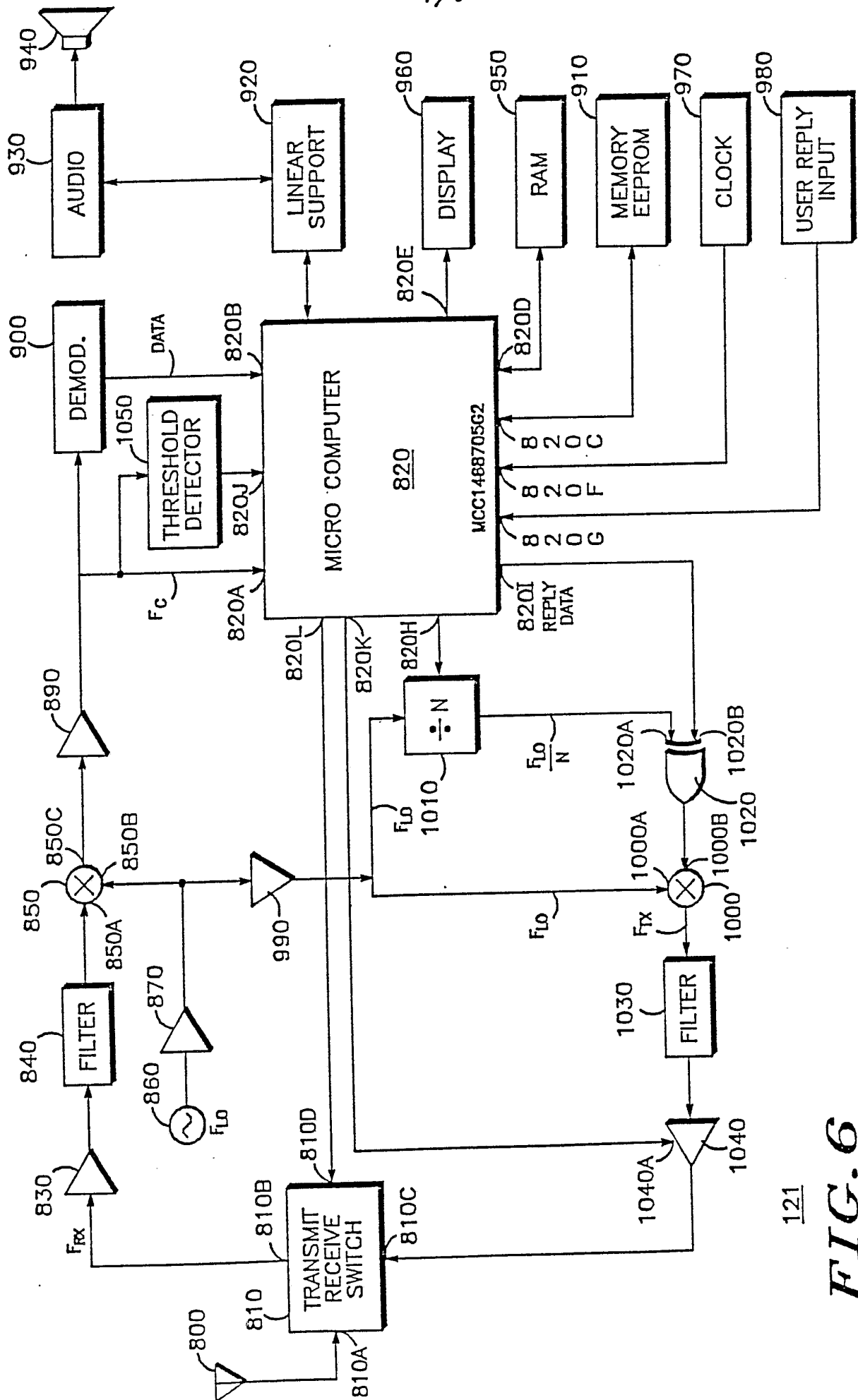

FIG. 5





121

FIG. 6

8/9

AB PAGER	PSEUDORANDOM CODE NUMBER	PSEUDORANDOM CODE AND STARTING POSITION
AB-1	1	BIT NO.1 → 100000
AB-2	2	BIT NO.7 → 011111
AB-3	3	110101
AB-4	4	010011
AB-5	5	001110
AB-6	6	111010
AB-7	7	010110
AB-8	8	001101
AB-9	9	111011
AB-10	10	010110
AB-11	11	110010
AB-12	12	010001
AB-13	13	110000
AB-14	14	101111
AB-15	15	100101
AB-16	16	011100
AB-17	17	110100
AB-18	18	010011
AB-19	19	110001
AB-20	20	BIT NO.115 → 010000
		1100000 ← BIT NO.127

FIG. 7

FIG. 8

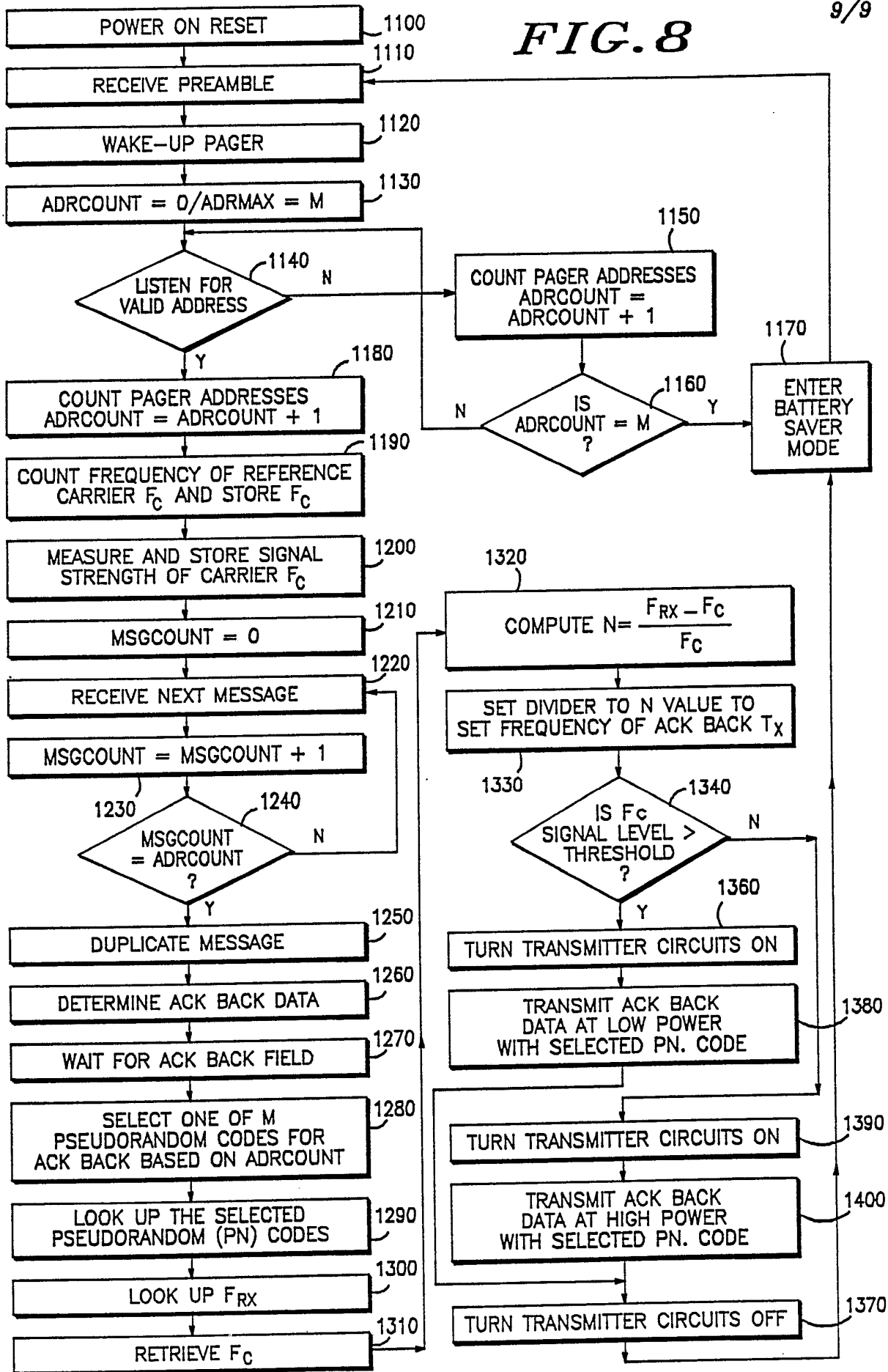

INTERNATIONAL SEARCH REPORT

International Application No. PCT/US88/04336

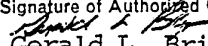
I. CLASSIFICATION OF SUBJECT MATTER (if several classification symbols apply, indicate all) ⁶		
According to International Patent Classification (IPC) or to both National Classification and IPC		
IPC(4) G 08 B 5/22 U.S. CL. 340/825.44, 311.1; 379/57; 370/18		
II. FIELDS SEARCHED		
Minimum Documentation Searched ⁷		
Classification System	Classification Symbols	
U.S.	340/311.1, 825.44, 825.47, 825.48; 370/18, 50, 69.1, 92, 93, 94; 379/56, 57; 455/31, 89	
Documentation Searched other than Minimum Documentation to the Extent that such Documents are Included in the Fields Searched ⁸		
III. DOCUMENTS CONSIDERED TO BE RELEVANT ⁹		
Category *	Citation of Document, ¹¹ with indication, where appropriate, of the relevant passages ¹²	Relevant to Claim No. ¹³
A	US, A, 3,973,200 (Akerberg) 03 August 1976.	
A	US, A, 4,208,630 (Martinez) 17 June 1980.	
A	US, A, 4,268,722 (Little et al) 19 May 1981.	
A	US, A, 4,352,955 (Kai et al) 05 October 1982.	
A	US, A, 4,466,001 (Moore et al) 14 August 1984.	
A	US, A, 4,590,473 (Burke et al) 20 May 1986.	
A	US, A, 4,646,082 (Engel et al) 24 February 1987.	
A	US, A, 4,713,808 (Gaskill et al) 15 December 1987.	
A	US, A, 4,765,753 (Schmidt) 23 August 1988.	
<p>* Special categories of cited documents: ¹⁰</p> <p>"A" document defining the general state of the art which is not considered to be of particular relevance</p> <p>"E" earlier document but published on or after the international filing date</p> <p>"L" document which may throw doubts on priority claim(s) or which is cited to establish the publication date of another citation or other special reason (as specified)</p> <p>"O" document referring to an oral disclosure, use, exhibition or other means</p> <p>"P" document published prior to the international filing date but later than the priority date claimed</p> <p>"T" later document published after the international filing date or priority date and not in conflict with the application but cited to understand the principle or theory underlying the invention</p> <p>"X" document of particular relevance; the claimed invention cannot be considered novel or cannot be considered to involve an inventive step</p> <p>"Y" document of particular relevance; the claimed invention cannot be considered to involve an inventive step when the document is combined with one or more other such documents, such combination being obvious to a person skilled in the art.</p> <p>"&" document member of the same patent family</p>		
IV. CERTIFICATION		
Date of the Actual Completion of the International Search	Date of Mailing of this International Search Report	
14 March 1988	08 MAY 1989	
International Searching Authority	Signature of Authorized Officer	
ISA/US	 Gerald L. Brigance	