



(86) Date de dépôt PCT/PCT Filing Date: 2003/09/17  
 (87) Date publication PCT/PCT Publication Date: 2004/04/01  
 (45) Date de délivrance/Issue Date: 2011/04/19  
 (85) Entrée phase nationale/National Entry: 2005/03/16  
 (86) N° demande PCT/PCT Application No.: JP 2003/011807  
 (87) N° publication PCT/PCT Publication No.: 2004/026385  
 (30) Priorité/Priority: 2002/09/20 (JP2002-276139)

(51) Cl.Int./Int.Cl. *A61M 25/01* (2006.01)

(72) Inventeurs/Inventors:  
 SAKANE, SHINICHI, JP;  
 YAMADA, HIROSHI, JP;  
 KOGAMORI, JUN, JP;  
 AOYAMA, CHISAKA, JP

(73) Propriétaire/Owner:  
 I.S.T CORPORATION, JP

(74) Agent: SMART & BIGGAR

(54) Titre : FIL GUIDE MEDICAL ET PROCEDE DE PRODUCTION ASSOCIE  
 (54) Title: MEDICAL GUIDE WIRE AND PROCESS FOR PRODUCTION THEREOF

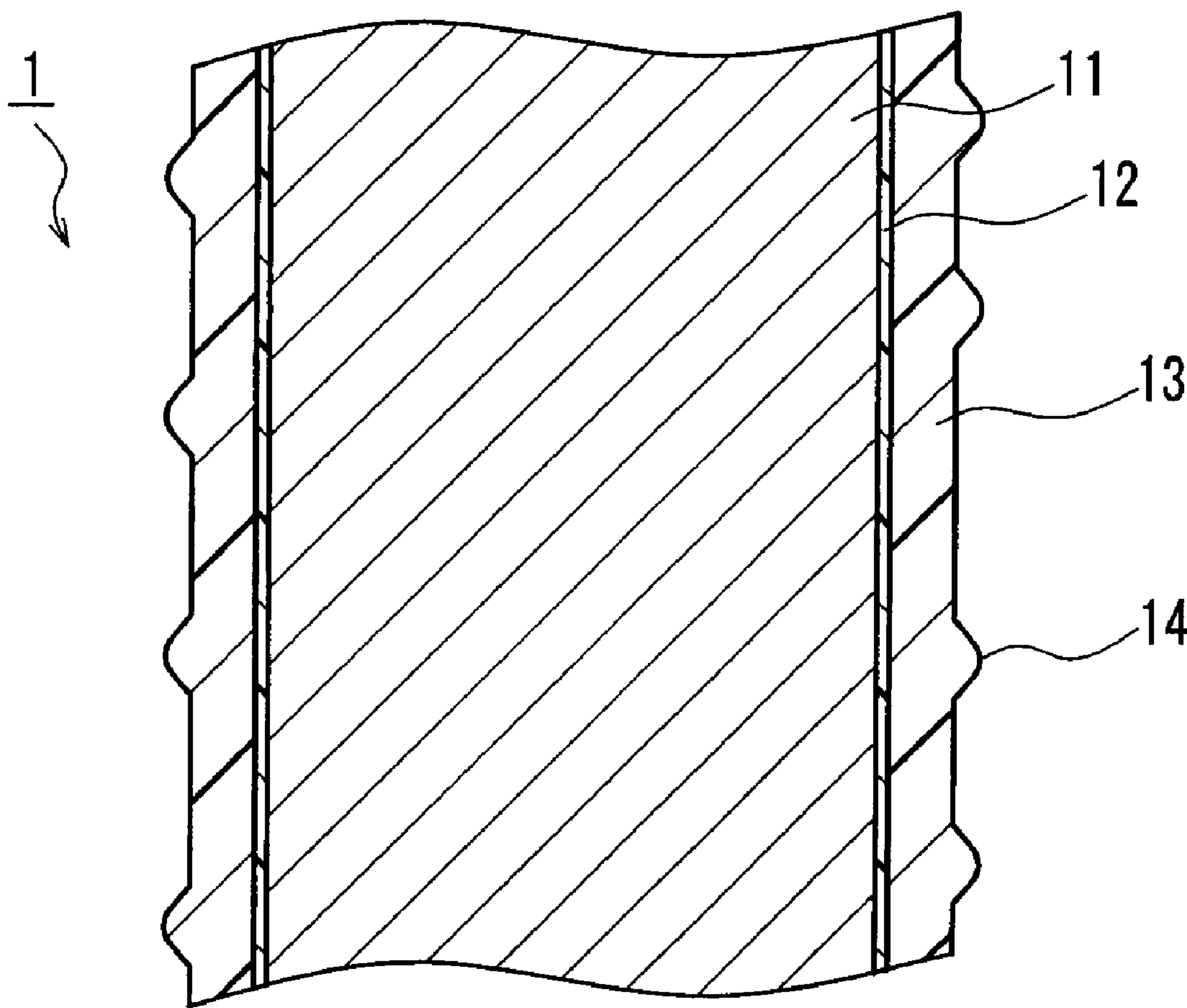

(57) Abrégé/Abstract:

A medical guide wire (1) is made in which at least a fluororesin coating layer (13) is formed on the surface of a metal wire (11), wherein particulate matter is present in the fluororesin coating layer (13), and the fluororesin coating layer covers the particulate

(57) **Abrégé(suite)/Abstract(continued):**

matter and at least some of the particulate matter is formed in surface protrusion-shaped projections (14). It is thus possible to provide a medical guide wire that is inexpensive to manufacture and whose strength is unaffected and frictional resistance is low, and manufacturing method for the same.

## ABSTRACT

A medical guide wire (1) is made in which at least a fluororesin coating layer (13) is formed on the surface of a metal wire (11), wherein  
5 particulate matter is present in the fluororesin coating layer (13), and the fluororesin coating layer covers the particulate matter and at least some of the particulate matter is formed in surface protrusion-shaped projections (14). It is thus possible to provide a medical guide wire that is inexpensive to manufacture and whose strength is unaffected and  
10 frictional resistance is low, and manufacturing method for the same.

## DESCRIPTION

MEDICAL GUIDE WIRE AND PROCESS FOR PRODUCTION  
THEREOF

5

## TECHNICAL FIELD

The present invention relates to medical guide wires used in guiding a catheter directly, or inserted through a blood vessel, into a person's body during a test or a medical procedure, and methods for manufacturing the same.

10

## BACKGROUND ART

Medical acts performed on the body impose a significant burden on the patient, and thus testing and medical procedures on the body have come to be performed by inserting a medical device such as a catheter directly into a body cavity in place of the conventional approach of making an incision. When using a catheter in this manner, a guide wire is passed through a catheter that is to be introduced to a target site within the body, and then the catheter is guided along the guide wire to that target site.

15

20

When inserting a catheter, the guide wire serving as the guide is inserted first and then the catheter is inserted into the body along the guide wire, and when there is little clearance between the catheter and the guide wire, or due to the blood influx at the time of insertion into the body, frictional resistance occurs and causes the guide wire to come into intimate contact with the inner circumferential surface of the catheter, increasing the likelihood of trouble. Consequently, to lower the frictional resistance between the guide wire and the catheter, the guide wire, that is, the core wire, is coated with fluororesin so that the guide wire can pass through the catheter with ease (JP H3-41966A).

25

30

However, although a guide wire whose core wire surface has been evenly coated with a fluororesin exhibits lower frictional resistance due to the low friction properties afforded by the fluororesin, the fluororesin comes into intimate contact with the inner circumferential surface of the catheter because it is applied evenly, and thus its effect was not sufficient. Accordingly, other proposals have been forwarded to further reduce the frictional resistance between the catheter and the guide wire, including

35

73466-109

providing the outer circumferential surface of the guide wire itself with an uneven shape having recessions and protrusions (JP H11-19217A), and wrapping a helical coil around its outside (JP H11-178930A, Tokuhyo 2000-509641).

5 However, in each of these conventional examples it was necessary to process the core material, and this complicated manufacturing, and there were also problems such as a change in the properties of the wire, for example its strength and modulus of elasticity, due to processing the core material, and an increase in costs due to core material processing, and moreover, there was the problem that the frictional resistance was not significantly improved.

## 10 DISCLOSURE OF INVENTION

In order to solve the foregoing conventional problems, it is an object of some embodiments of the present invention to provide a medical guide wire that is inexpensive to manufacture and whose strength is unaffected and frictional resistance is low, and a manufacturing method for the same.

15 According to one aspect of the present invention, there is provided a medical guide wire comprising: a metal wire having a uniform thickness or a tapered tip; and a fluoro-resin coating layer formed on a surface of the metal wire, wherein particulate matter is present in the fluoro-resin coating layer, and at a time of forming the fluoro-resin coating layer on the metal wire, the metal wire and  
20 fluoro-resin coating layer are baked at a temperature equal to or higher than a melting point of fluoro-resin constituting the fluoro-resin coating layer, whereby the fluoro-resin coating layer covers the particulate matter and at least some of the particulate matter is formed in surface protrusion-shaped projections.

According to another aspect of the present invention, there is  
25 provided a method for manufacturing a medical guide wire in which at least a fluoro-resin coating layer is formed on a surface of a metal wire, wherein the metal wire has a uniform thickness or a tapered tip; wherein the method comprises: mixing particulate matter for projections into a fluoro-resin dispersion to prepare a coating solution; applying the coating solution to the surface of the metal wire and  
30 drying the solution; baking by heating to at least a melting point of fluoro-resin in

73466-109

the fluoresin dispersion thereby causing particulate matter to be present in the fluoresin coating layer; wherein the fluoresin coating layer covers the particulate matter, and at least some of the particulate matter is formed in surface protrusion-shaped projections.

5           According to still another aspect of the present invention, there is provided a method for manufacturing a medical guide wire in which a primer layer and a fluoresin coating layer are formed in that order on a surface of a metal wire, wherein the metal wire has a uniform thickness or a tapered tip; wherein the method comprises: mixing particulate matter into at least one solution selected  
10 from a primer solution and a fluoresin dispersion solution; applying the primer solution and the fluoresin dispersion solution to the surface of the metal wire in that order and drying them; and baking by heating to at least a melting point of fluoresin in the fluoresin dispersion such that the fluoresin coating layer of an outermost layer covers the particulate matter and at least some of the  
15 particulate matter is formed in surface protrusion-shaped projections.

A medical guide wire of the present invention is a medical guide wire in which at least a fluoresin coating layer is formed on a surface of a metal wire, wherein particulate matter is present in the fluoresin coating layer, and the fluoresin coating layer covers the particulate matter and at least some of the  
20 particulate matter is formed in surface protrusion-shaped projections.

A method for manufacturing a medical guide wire of the present invention is a method for manufacturing a guide wire, in which at least a fluoresin coating layer is formed on a surface of a metal wire, that includes mixing particulate matter for projections into a fluoresin dispersion to prepare a  
25 coating solution, applying the solution to the surface of the metal wire and drying the solution, and then baking by heating to at least the melting point of the fluoresin in the fluoresin dispersion, to cause particulate matter to be present in the fluoresin coating layer, wherein the fluoresin coating layer covers the particulate matter and at least some of the particulate matter is formed in surface  
30 protrusion-shaped projections.

73466-109

Another method for manufacturing a medical guide wire according to the present invention is a method for manufacturing a medical guide wire, in which a primer layer and a fluorescein coating layer are formed in that order on a surface of a metal wire, that includes mixing particulate matter into at least one solution  
 5 selected from a primer solution and a fluorescein dispersion solution, applying the primer solution and the fluorescein solution to the surface of the metal wire in that order and drying them, and then, in a final process, baking by heating to at least the melting point of the fluorescein in the fluorescein dispersion such that the fluorescein coating layer of the outermost layer covers the particulate matter and  
 10 at least some of the particulate matter is formed in surface protrusion-shaped projections.

#### BRIEF DESCRIPTION OF DRAWINGS

FIG. 1 is a SEM photograph (220x) external view of the fluorescein coated wire obtained in Working Example 1 of the present invention.

15 FIG. 2 is a schematic cross-sectional view of the same.

FIG. 3 is an explanatory diagram showing the method for measuring the frictional resistance in the working examples of the present invention.

FIG. 4 is a SEM photograph (220x) external view of the fluorescein coated wire obtained in Comparative Example 1 of the present invention.

20 FIG. 5 is a SEM photograph (220x) external view of the fluorescein coated wire obtained in Comparative Example 2 of the present invention.

FIG. 6 is a SEM photograph (220x) external view of the fluorescein coated wire obtained in Working Example 3 of the present invention.

FIG. 7 is a schematic cross-sectional view of the same.

25 FIG. 8 is an explanatory diagram showing the method for measuring the height of the projections in the working examples of the present invention.

1,20 fluorescein coated wire

73466-109

- 2 tube made of resin
- 3 metal jig
- 4 clip
- 5 tensile tester
- 5 7 fastened chuck
- 11,21 superelastic alloy wire
- 12,22 primer layer
- 13,23 fluororesin coating layer

14,24 projections  
25 aluminum borate particles

#### BEST MODE FOR CARRYING OUT THE INVENTION

5 In the present invention it is possible to provide the particulate matter in either or both the primer layer and the fluoro-resin coating layer. In a final process, by baking by heating to at least the melting point of the fluoro-resin in the fluoro-resin dispersion, the fluoro-resin coating layer of the outermost layer covers the particulate matter. Particulate matter  
10 having a predetermined average particle diameter is used, and of these, comparatively large particles and agglomerated particles are formed in surface protrusion-shaped projections.

In a preferable example of the present invention, the fluoro-resin coating layer and the protruding projection-like fluoro-resin portions are  
15 baked as a single unit. Thus, the projection-like fluoro-resin particles are formed in smooth projections, and this contributes to lowering the frictional resistance. In other words, if the projections are smooth, then an object (resin tube) that comes into contact with them makes point contact, lowering the frictional resistance. As a result, this is useful for  
20 the medical guide wire for catheters, for example.

In the foregoing, whether or not the projections are smooth is determined based on observations made at 220× magnification by scanning electron microscope (SEM). When the magnification ratio is too small (for example, observations by the unaided eye), many of the  
25 projections will appear relatively smooth, whereas when the magnification ratio is too high (for example, 1000×), then many of the projections will appear extremely steep. Consequently, choosing the magnification ratio is very important. It should be noted that at a magnification ratio of 220×, the diameter portion of a medical guide wire  
30 whose diameter is approximately 0.35 mm fits into a single field of view, allowing the entire diameter portion to be observed and thus is favorable.

If the fluoro-resin coating layer includes particulate matter, then it is preferable that the particulate matter is fluoro-resin. The two being compatible allows them to be baked into a more robust single unit.

35 It is preferable that the fluoro-resin coating layer and the fluoro-resin projections include at least one selected from polytetrafluoroethylene (PTFE), tetrafluoroethylene-perfluoroalkylvinyl

ether copolymer (PFA), polychlorotrifluoroethylene (PCTFE), polyvinylidene fluoride (PVDF), polyvinyl fluoride (PVF), tetrafluoroethylene-hexafluoropropylene copolymer (FEP), and tetrafluoroethylene-ethylene copolymer (PETFE). Of these, at least one  
5 selected from polytetrafluoroethylene (PTFE) and tetrafluoroethylene-perfluoroalkylvinyl ether copolymer (PFA) is preferable. This is because of their relatively high melting point and the fact that they are safe for the human body.

It is preferable that the thickness of the fluororesin coating layer  
10 is at least 1  $\mu\text{m}$  and not more than 50  $\mu\text{m}$ . This is because this thickness does not effect the medical operation of the wire. It is also preferable that the average height of the projections is at least 0.1  $\mu\text{m}$  and not more than 20  $\mu\text{m}$ . This range is ideal for lowering friction. It is also preferable that the fluororesin coating layer surface has a mixture of flat  
15 portions and numerous projections. This shape is ideal for improving the friction characteristics. It is further preferable that the density of the protrusion-shaped fluororesin portions is at least an average of 1 per 0.01  $\text{mm}^2$  in order to lower friction.

Also, whereas it is preferable to have projection-like protrusion  
20 shapes in the fluororesin coating layer surface, to improve the roundedness of these projections, it is preferable that a fluororesin is coated onto a wire surface and baked to achieve a fluororesin coating layer by melting to form flat portions and also baking to melt the fluororesin particles for projections in a single unit with the fluororesin  
25 coating layer and form projection portions that after baking take on a smooth particle shape, thereby contributing to their roundness. To this end, it is preferable that non-baked fluororesin particles are dispersed in liquid to form the fluororesin dispersion, and also that particles that have been baked are mixed in with the fluororesin particles for projections.

It is also preferable to mix fluororesin having different melting  
30 points, and by mixing fluororesin particles having a higher melting point than the fluororesin dispersion into the fluororesin dispersion, which has a lower melting point, it is possible to form a fluororesin coating layer with excellent roundedness in which deformation of the fluororesin  
35 particles due to melting is suppressed. For example, it is possible to mix PTFE (melting point 327°C) particles for projections into a dispersion of FEP (melting point 255 to 265°C) or PFA (melting point 305°C), or to mix

PTFE particles for projections that have been baked into a non-baked PTFE dispersion, and depending on the conditions, various combinations of these are possible.

5 A method for manufacturing a medical guide wire of the present invention is a method for manufacturing a guide wire, in which a fluororesin layer is formed on a surface of a metal wire, that includes mixing fluororesin particles for projections into a fluororesin dispersion to prepare a coating solution, applying the solution to the surface of the metal wire, and then baking by heating to at least the melting point of the  
10 fluororesin dispersion, thereby forming a fluororesin coating and projection-like fluororesin portions protruding from the fluororesin coating as a single unit on the surface of the metal wire, forming rounded projections.

The method for applying the fluororesin dispersion or the primer  
15 solution to the guide wire surface can be any one of brushing, spraying, or the like, but in order to achieve a uniform application, a dipping method is preferable. The temperature at which the fluororesin is baked is between 300 and 450°C, and thus after baking the fluororesin coated wire, the fluororesin is cooled quickly from a molten state, thereby annealing  
20 the metal wire and preventing the loss of rigidity as well as obtaining a hard coating layer due to the fluororesin layer cooling quickly. Here, cooling quickly means cooling of the fluororesin from a molten state at a rate of about 50 to 100°C per second. The preferable conditions can be determined based on the wire diameter and material of the metal wire  
25 and the thickness and baking temperature of the fluororesin.

In the method of the invention, it is preferable that the fluororesin solid content concentration in the fluororesin dispersion for coating is 20 to 60 wt%. Within this range, the dispersion is stable.

It is preferable that when A is an amount of the fluororesin  
30 particles for forming projections that is added and B is the solid content of the fluororesin dispersion, then  $[A/(A+B)] \times 100$  is 1 to 60 wt%. This is because it gives favorable low friction properties. It is preferable that the average particle diameter of the fluororesin microparticles for coating within the fluororesin dispersion is approximately 0.20 to 0.30  $\mu\text{m}$  when  
35 measured by a light dispersion method. It is also preferable that the average particle diameter of the fluororesin particles for projections is at least 0.5 and not more than 30  $\mu\text{m}$ . This range is ideal for lowering

friction. It should be noted that if the diameter of the fluoro-resin particles for projections is larger than the thickness of the fluoro-resin coating, then because they are baked into a single unit with the fluoro-resin for coating, most are deformed due to melting and become smooth projections. If the diameter of the fluoro-resin particles for projections is smaller than the thickness of the fluoro-resin coating, then the amount of fluoro-resin particles for projections that is added can be increased to stack the particles on one another and thereby cause them to protrude from the coating.

10 In the present invention it is possible to mix particulate matter into the primer layer. By doing this, the fluoro-resin coating layer, which is the outermost layer, covers the particulate matter, allowing the particulate matter to form protrusion-shaped surface projections. Here, the primer layer is a layer for increasing the intimacy of contact between  
15 the metal surface of the guide wire and the outermost fluoro-resin layer. In this case, it is preferable that the particulate matter is fluoro-resin or a heat-resistant substance having a higher melting point than the fluoro-resin coating layer. This is because projections of particle are formed conspicuously after the fluoro-resin is baked. The particulate  
20 matter can be at least one type of particle selected from fluoro-resin, glass, metal, plastic, inorganic powder, and ceramic. It is preferable that the average particle diameter of the particulate matter is at least the film thickness of the primer layer, and preferably the average particle diameter is in the range of 0.5 to 30  $\mu\text{m}$ . It is also preferable that the  
25 thickness of the fluoro-resin coating layer is at least 1  $\mu\text{m}$  and not more than 50  $\mu\text{m}$ . It is also preferable that the average height of the projections is at least 0.1  $\mu\text{m}$  and not more than 20  $\mu\text{m}$ . It is also preferable that the amount of particulate matter that is present is 1 to 50 wt% with respect to the solid content mass of the primer solution.

30 A metal wire that has a uniform thickness or whose tip is tapered can be employed favorably as the metal wire in the present invention. The wire material is preferably a superelastic alloy, and for example is Ti-Ni (Ni: 49-51 atomic%, including Ti-Ni to which a third element has been added), Cu-Al-Zn (Al: 3-8 atomic%, Zn: 15-28 atomic%), Fe-Mn-Si  
35 (Mn: 30 atomic%, Si: 5 atomic%), Cu-Al-Ni (Ni: 3-5 atomic%, Al: 28-29 atomic%), Ni-Al (Al: 36-38 atomic%), Mn-Cu (Cu: 5-35 atomic%), or Au-Cd (Cd: 46-50 atomic%). These alloys are known as superelastic alloys or

shape memory alloys. Of these, a Ti-Ni alloy is preferable. Its thickness preferably is selected based on the inner diameter of the catheter with which it is to be used in combination. More specifically, wires having a diameter of approximately 0.3 mm to 1 mm are frequently used.

### *Working Examples*

Hereinafter, the present invention is described in more specific detail using working examples.

#### (1) Method of Measuring the Frictional Resistance

As shown in FIG. 3, a polyurethane resin tube (inner diameter 2.5 mm, outer diameter 4.0 mm, length 200 mm) 2 is fixedly adhered over half its circumference to a metal jig 3 having a diameter of 90 mm, and the jig 3 is attached to a fastened chuck 7 of a tensile tester.

Next, a fluororesin coated wire 1 is inserted into the polyurethane resin tube and one end of the wire is fastened to a clip 4 of the tensile tester 5, while the other free end is pulled at a velocity of 50 mm per minute in the direction of an arrow 6, and by measuring the load at this time, the frictional resistance between the wire 1 and the polyurethane resin tube was measured. The smaller the tensile strength, the smaller the frictional resistance. The measurement was performed by measuring the frictional resistance over any 50 mm portion of the guide wire, and recording those values to a chart and calculating an average value from the data.

#### (2) Method of Measuring the Height of the Projections Coated by Fluororesin

Measurement was performed under the following conditions using the super depth-shape measuring microscope "VK-8550" made by KEYENCE CORPORATION of Japan.

Emission Laser: semiconductor laser, wavelength 685 nm

Output: 0.45 mW

Magnification Ratio: 100x

Measurement Depth: 5  $\mu$ m

Movement Pitch: 0.05  $\mu$ m

Laser Scan: 9 Hz

Laser Emission Angle: Vertical (emission straight downward from above, and reflection light is received by a light-receiving portion)

Regarding the measuring method, as shown in FIG. 8 a laser light a1 is emitted straight down and the reflection light a2 is received by a light-receiving portion that is not shown, and from its focal length the distance (depth) of the section in question is measured. Projections 14 also are measured in this fashion, emitting a laser light b1 and receiving reflection light b2, and from that focal length obtaining the distance of that position by measurement. In other words, the unevenness of a sample is successively obtained by measurement over a fixed area of the sample from that focal length, calculating the height of the projections 14 regarding the a1 emission portions as flat portions. Measurements are calculated as the average value of five measured values per sample.

#### 15 *Working Example 1*

A primer solution ("855-300" made by Dupont) having a 35% solid portion concentration) adjusted to a viscosity of 110 cp (23°C) was coated onto a 2 m length, 0.35 mm diameter Ti-Ni (Ni: 49-51 atomic%) superelastic alloy wire to a dried thickness of approximately 1  $\mu\text{m}$  and then dried naturally at room temperature for 10 minutes. It was then heated at 150°C for 30 minutes.

Separately, a fluoro-resin dispersion for coating ("855-510" made by Dupont) was used as the fluoro-resin of the outermost layer. The fluoro-resin solid concentration was 50 wt%. PTFE particles for forming projections ("L150J" made by Asahi Glass) (average particle diameter approximately 9  $\mu\text{m}$ ) were added to this dispersion to 20 wt% with respect to the fluoro-resin mass of the dispersion and then mixed, and this was taken as the coating liquid.

The coating liquid was coated over the wire, which had been coated by the primer solution, dried naturally at room temperature (25°C) for 1 minute, heated at 200°C for 10 minutes, then baked at 450°C for 1 minute and cooled to room temperature. The thickness of flat portions of the fluoro-resin coating layer was approximately 5  $\mu\text{m}$ , and the average height of projections was approximately 3.5  $\mu\text{m}$ .

FIG. 1 shows the external appearance of the fluoro-resin coated wire obtained in this manner. FIG. 1 is a scanning electron microscope (SEM) photograph taken at 220x magnification. It is clear from FIG. 1

that a fluoro-resin coating layer and projections at a ratio of at least an average of 1 per 0.01 mm<sup>2</sup> are formed in the fluoro-resin coating layer surface, that the fluoro-resin particles and the fluoro-resin are baked into a single unit, and that the projection-like fluoro-resin particles are formed in smooth protrusions.

FIG. 2 is a schematic cross-sectional view of FIG. 1. The fluoro-resin coated wire 1 is made of a primer layer 12, a fluoro-resin coating layer 13, and projections 14 due to the fluoro-resin particles, baked into a single unit on the surface of a superelastic alloy wire 11.

The frictional resistance of the fluoro-resin coated wire thus obtained was measured. The result was an average frictional resistance value for the wire of Working Example 1 of 2.0 g.

#### *Working Example 2*

Other than using a dispersion in which microparticles of PFA, which have a lower melting point than PTFE, have been dispersed for the fluoro-resin coating dispersion for the coating of Working Example 1 and changing the baking temperature when baking to form the fluoro-resin coating, the same experiment as that of Working Example 1 was performed. PTFE particles for forming projections (average particle diameter approximately 9 μm) were added to the dispersion of PFA microparticles to 20 wt% with respect to the fluoro-resin mass and mixed and then coated onto a 2 m length, 0.35 mm diameter superelastic alloy wire. After coating was finished, the result was dried naturally at room temperature for 1 minute, heated at 200°C for 10 minutes, then baked at 380°C for 1 minute and cooled to room temperature. The thickness of the flat portions of the fluoro-resin coating was approximately 5 μm, and the average height of the projections was approximately 4 μm. The average frictional resistance value of the wire of Working Example 2 was 1.8 g.

#### *Comparative Example 1*

Other than no PTFE particles for forming projections being added to the fluoro-resin dispersion in Working Example 1, the same fluoro-resin coating as in Working Example 1 was formed.

FIG. 4 shows the external appearance of the fluoro-resin coated wire. FIG. 4 is a scanning electron microscope (SEM) photograph taken

73466-109

at 220x magnification. It is clear from FIG. 4 that a fluororesin coating layer having a uniform thickness was formed.

The frictional resistance value of this fluororesin coated wire was measured in the same manner as in Working Example 1, and the average  
5 frictional resistance value of the wire was found to be 4.5 g.

#### *Comparative Example 2*

PTFE particles having an average particle diameter of 9  $\mu\text{m}$  were applied as a fine powder over the wire surface and the fluororesin was  
10 baked for 1 minute at a temperature of 450°C.

FIG. 5 shows the external appearance of the fluororesin coated wire. FIG. 5 is a scanning electron microscope (SEM) photograph taken at 220x magnification. It is clear from FIG. 5 that the fluororesin coating layer has an uneven shape.

15 The frictional resistance of this fluororesin coated wire was measured as in Working Example 1, and the average frictional resistance value of the wire was found to be 3.8 g.

#### *Working Example 3*

20 A 2 m length, 0.35 mm diameter Ti-Ni (Ni: 49-51 atomic%) superelastic alloy wire was prepared. Next, 10 wt% aluminum borate "PF03" (made by Shikoku Chemicals Corporation) having a 3  $\mu\text{m}$  average particle diameter was mixed in and dispersed to "855-300" (made by Dupont) having a 35% solid concentration to serve as a primer solution,  
25 and its viscosity was adjusted to 110 cp (23°C). The primer was then coated by an immersion method until a dried thickness of approximately 1.0  $\mu\text{m}$ , dried naturally at room temperature for 10 minutes, and then heated at 150°C for 30 minutes. Regarding the dried primer coating surface, the numerous aluminum borate projections precipitated on the  
30 wire surface were applied along with the primer coating.

Next, a fluororesin dispersion for coating ("AD-1" made by Asahi Glass), where the average diameter of the fluororesin microparticles made of PTFE was measured by light dispersion to be approximately 0.20  $\mu\text{m}$ , was used for the outermost fluororesin layer. The fluororesin solid  
35 content concentration was 60 wt%, and using (Triton<sup>™</sup>) polyoxyethylene (10) octylphenyl ethyl was adjusted to a viscosity of 150 CP, and this dispersion was taken as the coating liquid of the outermost fluororesin

layer.

This coating liquid was coated by dripping onto the surface of the wire that had been coated with the primer solution, dried naturally at room temperature for 1 minute, heated at 200°C for 10 minutes, then  
5 baked at 400°C for 1 minute and cooled to room temperature. The thickness of the flat portions of the fluororesin coating layer was approximately 6  $\mu\text{m}$ , and the average height of the projections was approximately 2.0  $\mu\text{m}$ .

FIG. 6 shows the external appearance of the fluororesin coated  
10 wire obtained in this manner. FIG. 6 is a scanning electron microscope (SEM) photograph taken at 220x magnification. It is clear from FIG. 6 that a guide wire having a coating layer in which the projection-like shapes of the aluminum borate particles mixed into the primer solution were formed as rounded projections coated by the fluororesin on the  
15 fluororesin coating layer surface was obtained.

FIG. 7 is a schematic cross-sectional view of the guide wire of this working example. A fluororesin coated wire 20 is made of a primer layer 22, to which aluminum borate particles 25 have been mixed, and a fluororesin coating layer 23 layered onto the surface of a superelastic  
20 alloy wire 21, and the projections 24 in which the aluminum borate particles 25 are coated by the fluororesin layer are coated such that they form smooth projection shapes.

The average frictional resistance value of the fluororesin coated wire thus obtained was 1.5 g.

25

#### *Working Example 4*

To the primer solution of Working Example 3, PTFE particles ("L150J" made by Asahi Glass) (9  $\mu\text{m}$  average particle diameter) were added in place of the aluminum borate to 20 wt% with respect to the solid  
30 concentration of the primer solution and this was mixed, and then this primer solution was coated by immersion to a thickness of 2  $\mu\text{m}$  onto a 2 m length, 0.35 mm diameter superelastic alloy wire. The primer solution was then dried naturally at room temperature for 10 minutes and heated at 150°C for 30 minutes and dried. Regarding the dried  
35 primer coated surface, the numerous fluororesin projections precipitated on the wire surface were applied along with the primer coating. Then, coating by immersion using a dispersion in which microparticles of PFA,

which have a lower melting point than PTFE, are dispersed was performed, this was dried naturally at room temperature for 1 minute, heated at 200°C for 10 minutes, then baked at 380°C for 1 minute and cooled to room temperature. The thickness of the flat portions of the fluororesin coating was approximately 7  $\mu\text{m}$ , and the height of the projections was approximately 5  $\mu\text{m}$ . The average frictional resistance value was 1.8 g.

It is clear from the above working examples and comparative examples that the wire of the present invention, in which a fluororesin coating layer and fluororesin particles for forming projections are baked as a single unit and the projection-like fluororesin particles form smooth protrusions, had the lowest frictional resistance value.

#### INDUSTRIAL APPLICABILITY

With the medical guide wire of the present invention, the fluororesin coating layer and the projections made of particulate matter protruding from the fluororesin coating layer surface are baked into a single unit and the protrusions are formed rounded, and thus the frictional resistance between the catheter and the guide wire can be reduced, making the action of inserting the catheter into the body easy. Also, it is not necessary to process, for example deform, the core material itself, and thus characteristics of the core material such as its strength and modulus of elasticity can be utilized as they are.

With the method of the present invention it is possible to effectively, efficiently, and inexpensively manufacture the medical guide wire of the present invention.

73466-109

CLAIMS:

1. A medical guide wire comprising:  
a metal wire having a uniform thickness or a tapered tip; and  
a fluorescein coating layer formed on a surface of the metal wire,  
5 wherein particulate matter is present in the fluorescein coating layer,  
and at a time of forming the fluorescein coating layer on the metal wire, the metal  
wire and fluorescein coating layer are baked at a temperature equal to or higher  
than a melting point of fluorescein constituting the fluorescein coating layer,  
whereby the fluorescein coating layer covers the particulate matter and at least  
10 some of the particulate matter is formed in surface protrusion-shaped projections.
2. The medical guide wire according to claim 1,  
wherein a primer layer is further formed within the fluorescein coating  
layer;  
wherein the particulate matter is present in at least one layer  
15 selected from the primer layer and the fluorescein coating layer; and  
wherein the fluorescein coating layer of the outermost layer covers  
the particulate matter and at least some of the particulate matter is formed in the  
surface protrusion-shaped projections.
3. The medical guide wire according to claim 1 or 2,  
20 wherein the fluorescein coating layer includes the particulate matter,  
the particulate matter is fluorescein, and the fluorescein coating layer and the  
particulate matter are baked as a single unit.
4. The medical guide wire according to claim 1 or 2,  
wherein the fluorescein coating layer and the particulate matter  
25 include at least one selected from a group consisting of polytetrafluoroethylene  
(PTFE), tetrafluoroethylene-perfluoroalkylvinyl ether copolymer (PFA),

73466-109

polychlorotrifluoroethylene (PCTFE), polyvinylidene fluoride (PVDF), polyvinyl fluoride (PVF), tetrafluoroethylene-hexafluoropropylene copolymer (FEP), and tetrafluoroethylene-ethylene copolymer (PETFE).

5. The medical guide wire according to any one of claims 1 to 4,  
5 wherein a thickness of the fluororesin coating layer is at least 1  $\mu\text{m}$  and not more than 50  $\mu\text{m}$ .
6. The medical guide wire according to claim 1,  
wherein an average height of the projections is at least 0.1  $\mu\text{m}$  and not more than 20  $\mu\text{m}$ .
- 10 7. The medical guide wire according to claim 1,  
wherein the fluororesin coating layer surface has a mixture of flat portions and numerous protrusion-shaped projections.
8. The medical guide wire according to any one of claims 1, 6, or 7,  
15 wherein a density of the protrusion-shaped projections is at least an average of 1 per 0.01  $\text{mm}^2$ .
9. The medical guide wire according to claim 2,  
wherein the particulate matter is present in the primer layer, and the particulate matter is fluororesin or a heat-resistant substance having a higher melting point than the fluororesin coating layer.
- 20 10. The medical guide wire according to claim 9,  
wherein the particulate matter is at least one selected from a group consisting of glass particles, metal particles, plastic particles, inorganic particles, and ceramic particles.

73466-109

11. The medical guide wire according to claim 9,

wherein an average particle diameter of the particulate matter is at least a film thickness of the primer layer, and an average particle diameter is in a range of 0.5 to 30  $\mu\text{m}$ .

5 12. A method for manufacturing a medical guide wire in which at least a fluorescein coating layer is formed on a surface of a metal wire,

wherein the metal wire has a uniform thickness or a tapered tip;

wherein the method comprises:

10 mixing particulate matter for projections into a fluorescein dispersion to prepare a coating solution;

applying the coating solution to the surface of the metal wire and drying the solution;

15 baking by heating to at least a melting point of fluorescein in the fluorescein dispersion thereby causing particulate matter to be present in the fluorescein coating layer;

wherein the fluorescein coating layer covers the particulate matter, and at least some of the particulate matter is formed in surface protrusion-shaped projections.

20 13. A method for manufacturing a medical guide wire in which a primer layer and a fluorescein coating layer are formed in that order on a surface of a metal wire,

wherein the metal wire has a uniform thickness or a tapered tip;

wherein the method comprises:

25 mixing particulate matter into at least one solution selected from a primer solution and a fluorescein dispersion solution;

73466-109

applying the primer solution and the fluororesin dispersion solution to the surface of the metal wire in that order and drying them; and

baking by heating to at least a melting point of fluororesin in the fluororesin dispersion such that the fluororesin coating layer of an outermost layer  
5 covers the particulate matter and at least some of the particulate matter is formed in surface protrusion-shaped projections.

14. The method for manufacturing the medical guide wire according to claim 12 or 13,

wherein a fluororesin solid content concentration in the fluororesin  
10 dispersion solution is 20 to 60 wt%.

15. The method for manufacturing the medical guide wire according to any one of claims 12 to 14,

wherein when A is an amount of the particulate matter that is added and B is a solid content of the fluororesin dispersion, then  $[A/(A+B)] \times 100$  is 1  
15 to 60 wt%.

16. The method for manufacturing the medical guide wire according to claim 12 or 13,

wherein an average particle diameter of the particulate matter is 0.5 to 30  $\mu\text{m}$ .

20 17. The method for manufacturing the medical guide wire according to claim 13,

wherein the particulate matter is mixed into the primer solution to prepare a coating solution.

18. The method for manufacturing the medical guide wire according to  
25 claim 17,

73466-109

wherein an amount of the particulate matter that is present is 1 to 50 wt% with respect to a solid content mass of the primer solution.

Application number / numéro de demande: JP03 / 11807

Figures: 1, 4, 5, 6

Pages: \_\_\_\_\_

DRW - IP

Unscannable items  
received with this application  
(Request original documents in File Prep. Section on the 10<sup>th</sup> floor)

Documents reçu avec cette demande ne pouvant être balayés  
(Commander les documents originaux dans la section de préparation des dossiers au  
10<sup>ème</sup> étage)

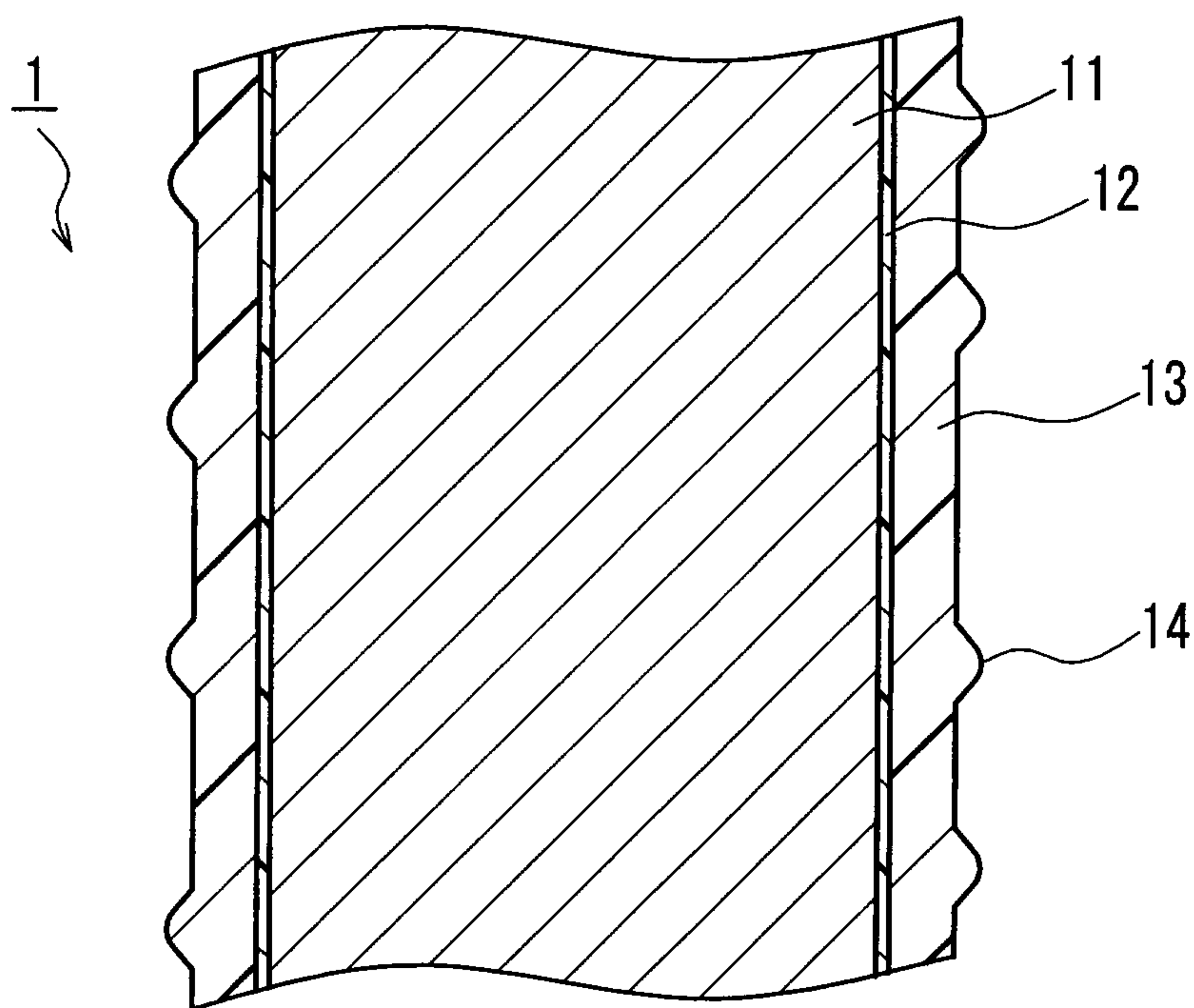

FIG. 2

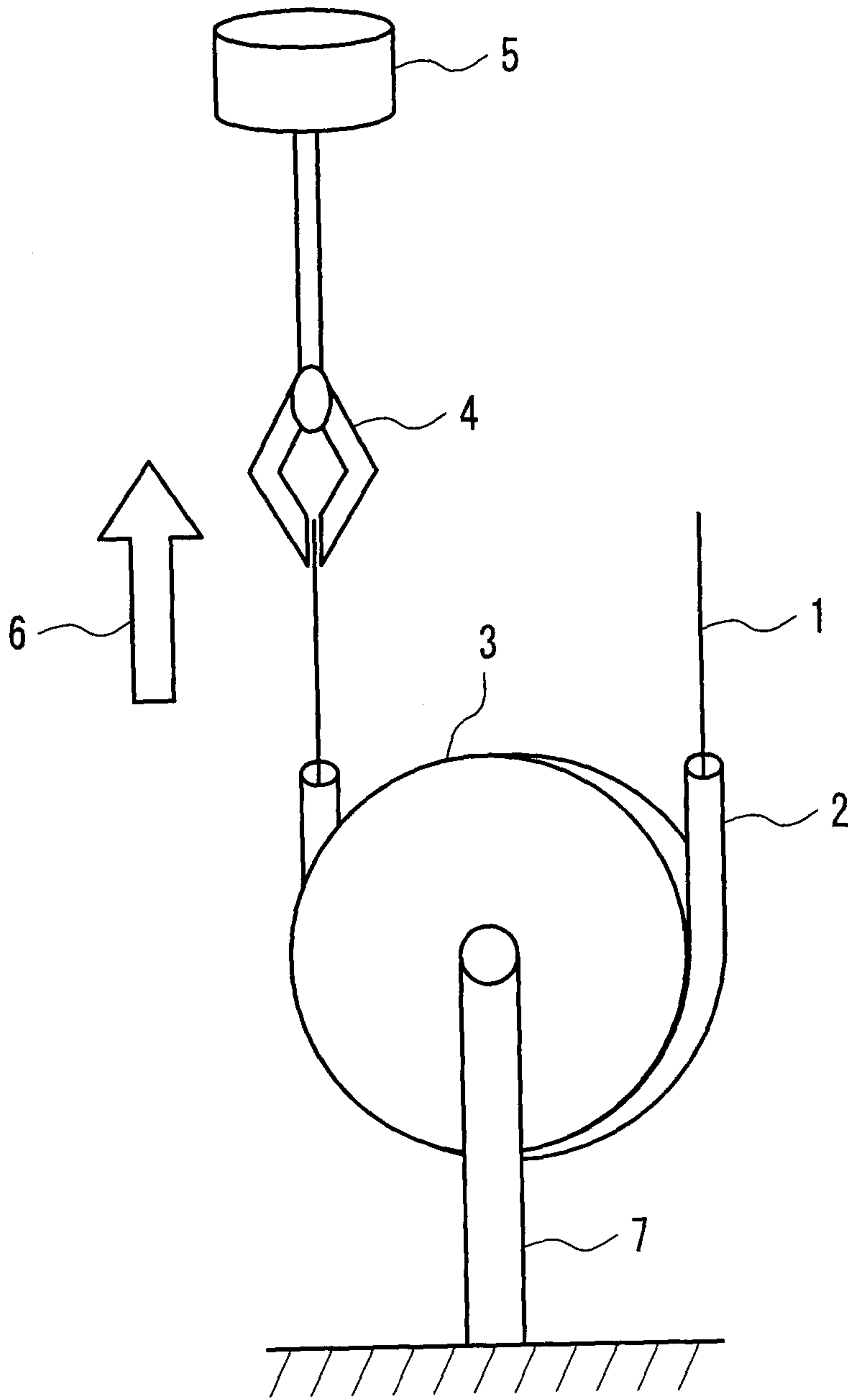

FIG. 3

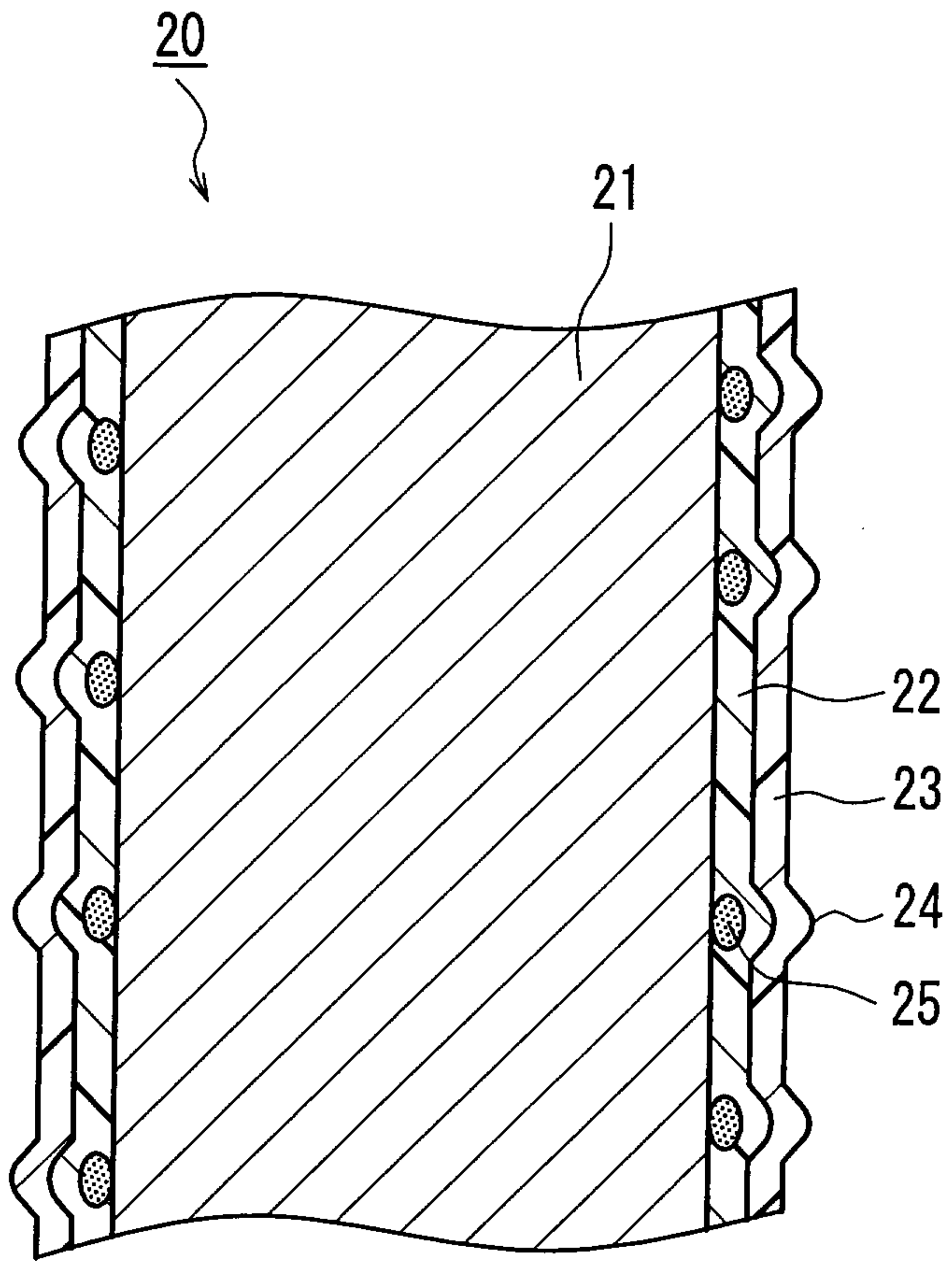

FIG. 7

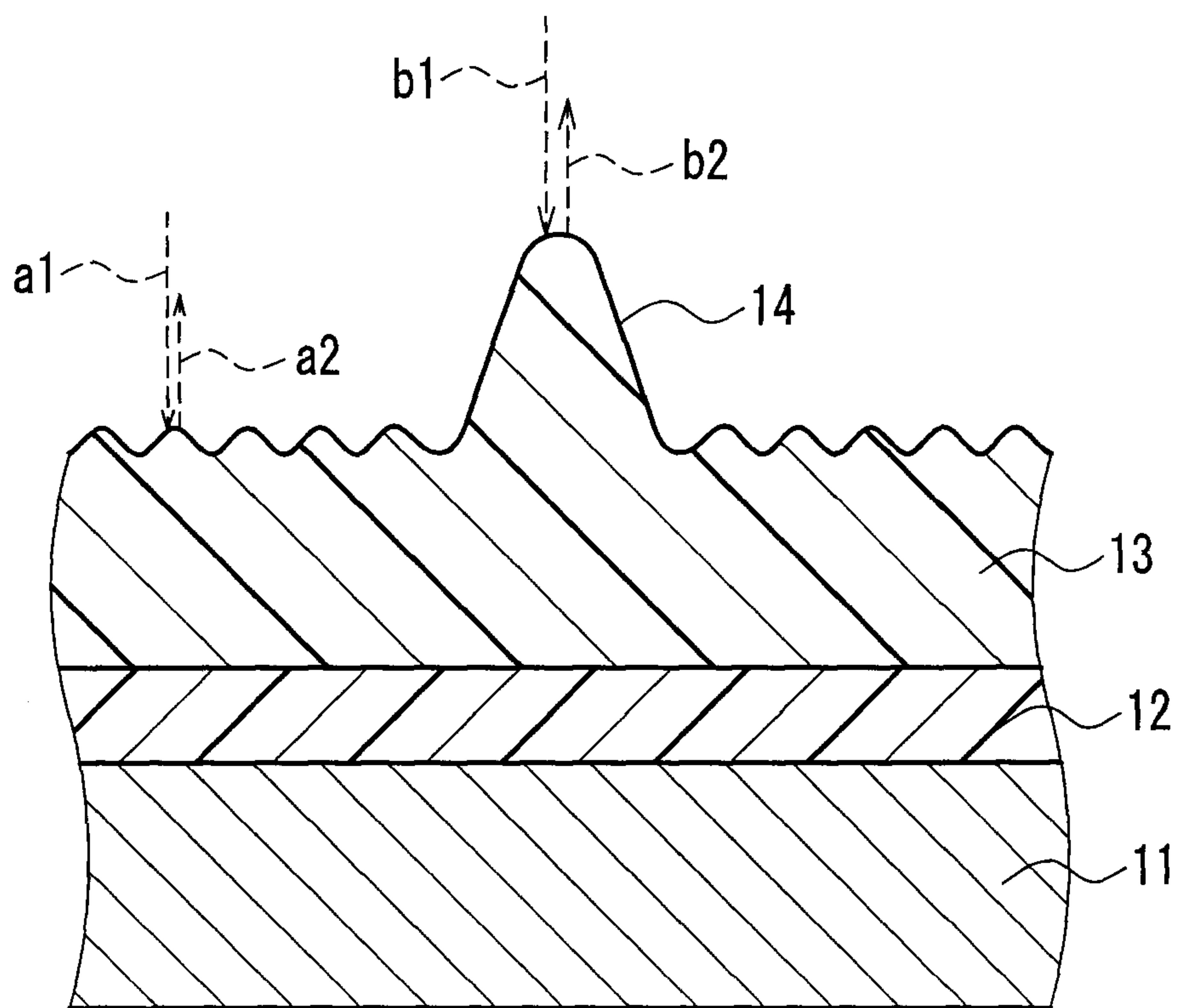

FIG. 8

