

(No Model.)

2 Sheets—Sheet 1.

A. NIEMCZIK.
WICKLESS LAMP.

No. 524,093.

Patented Aug. 7, 1894.

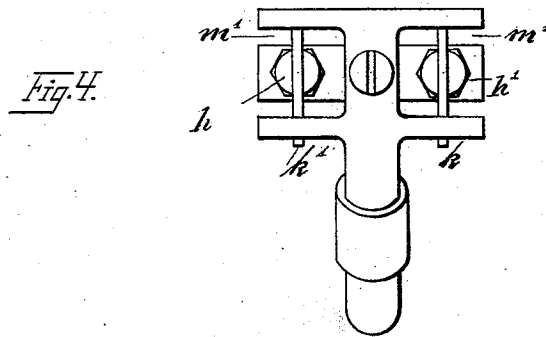
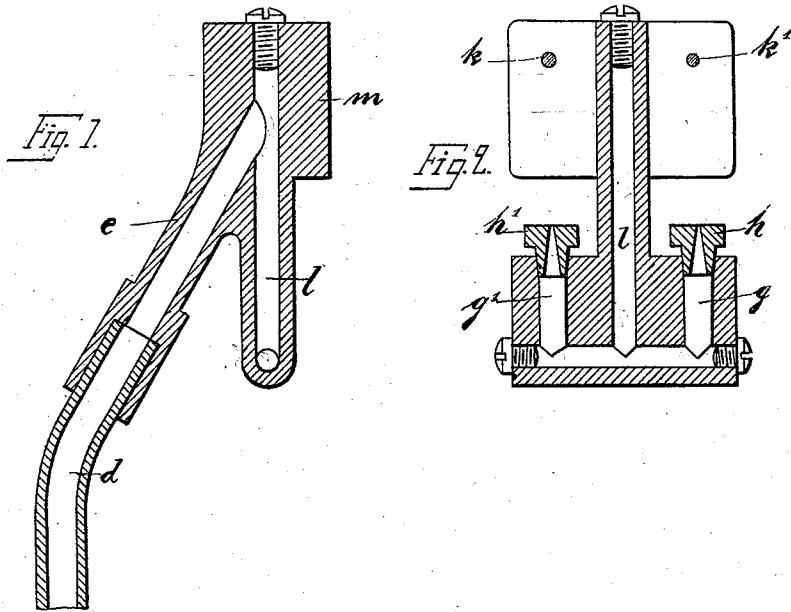

Witnesses:
E. Pybischn
F. Kolbitzsch

Inventor:
Anton Niemczik
per Gerson Jachke
his Attorneys.

A. NIEMCZIK.
WICKLESS LAMP.

No. 524,093.

Patented Aug. 7, 1894.

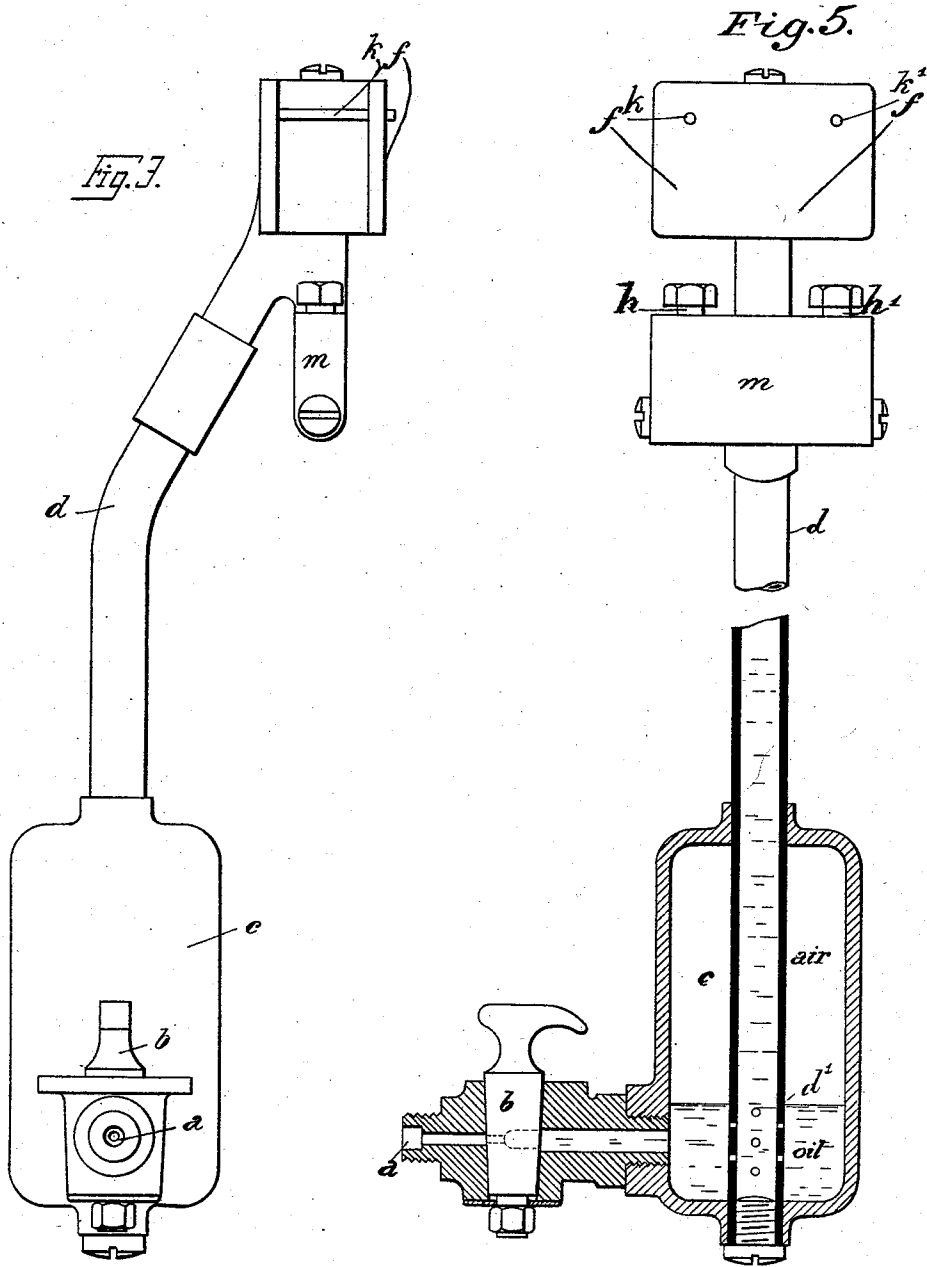

Witnesses:
E. Diebisch
P. Kobilitsch.

Inventor:
Anton Niemczik
Joer Gerson and Sacher
his Attorneys.

UNITED STATES PATENT OFFICE.

ANTON NIEMCZIK, OF LEIPSIC, GERMANY.

WICKLESS LAMP.

SPECIFICATION forming part of Letters Patent No. 524,093, dated August 7, 1894.

Application filed May 6, 1893. Serial No. 473,269. (No model.)

To all whom it may concern:

Be it known that I, ANTON NIEMCZIK, a subject of the Emperor of Germany, residing at Eutritzsch, Leipsic, in the Empire of Germany, have invented a new and useful Improvement in Wickless Lamps for Burning Petroleum under Pressure, of which the following is a specification.

The present invention relates to a wickless lamp which is maintained by the petroleum standing under pressure, and which is chiefly used for heating purposes.

In the here annexed drawings Figure 1 is the longitudinal section of the lamp. Fig. 2 is the section through the burner. Fig. 3 is the side-view, and Fig. 4 is the bottom view of the burner. Fig. 5 is partially the side-view and partially the longitudinal section of the lamp.

Through the pipe *a*, which is provided with a cock *b*, the petroleum is pressed into the vessel *c* through which passes pipe *d*. The lower end of the pipe *d* is fixed to the elbow-piece *e* carrying the two metal blocks *f* and *m*. Block *m* is provided with two angular bores *g g'* which join to the vertical bore *l* of the elbow-piece *e*. In the ends of the bores *g g'* are the burners *h h'* which are provided with very fine holes. Block *m* has two angular recesses *m'* in which are the pins *k k'*.

In order to light the lamp, pipe *d* is heated near the vessel *c* by means of a spirit flame or such like. Consequently the petroleum,

pressed into the air chamber by means of pipe *a*, is evaporated and the vapors enter through the bores *d'* into pipe *d*; from there they pass through the bores *l g g'*, and with great pressure out of the holes of the burners *h h'*. It is evident that in the beginning by heating the chamber *c* the air will be expelled out of this chamber. By opening the cock *b* more or less, only such quantity of oil is admitted into the chamber *c* as is gasified by the heat. The oil admitted through cock *b* sinks down by its gravity onto the bottom of the chamber *c*. The ignition is effected at the burners *h h'*. The pins *k k'* serve to limit the flame developed. Through the flame leaking into the recesses *m' m'*, the block *m*, the elbow *e* and consequently also pipe *d* are strongly heated, so that the further development of the petroleum-gases in the vessel *c* takes place also after the flame used at first for developing the gases, is removed, and the lamp continues to burn.

What I claim is—

In a wickless lamp for burning petroleum under pressure the combination of the elbow-piece *e* with the block *f*, to which are secured the burners *h h'* and the block *m* provided with the recesses *m' m'* and the pins *k k'* as and for the purpose specified.

ANTON NIEMCZIK.

Witnesses:

CARL BORNGRAEBER,
ROBERT FREIER.