

(19) World Intellectual Property
Organization
International Bureau



(43) International Publication Date
26 August 2004 (26.08.2004)

PCT

(10) International Publication Number
WO 2004/071912 A1

(51) International Patent Classification⁷: **B65G 65/32**,
21/12, 69/04

(21) International Application Number:
PCT/US2004/003214

(22) International Filing Date: 3 February 2004 (03.02.2004)

(25) Filing Language: English

(26) Publication Language: English

(30) Priority Data:
60/445,760 5 February 2003 (05.02.2003) US

(71) Applicant and

(72) Inventor: **KINZER, Dwight, Eric** [US/US]; P. Box 277,
Circle Pines, MN 55014-0277 (US).

(81) Designated States (*unless otherwise indicated, for every
kind of national protection available*): AE, AG, AL, AM,
AT, AU, AZ, BA, BB, BG, BR, BW, BY, BZ, CA, CH, CN,
CO, CR, CU, CZ, DE, DK, DM, DZ, EC, EE, EG, ES, FI,

GB, GD, GE, GH, GM, HR, HU, ID, IL, IN, IS, JP, KE,
KG, KP, KR, KZ, LC, LK, LR, LS, LT, LU, LV, MA, MD,
MG, MK, MN, MW, MX, MZ, NA, NI, NO, NZ, OM, PG,
PH, PL, PT, RO, RU, SC, SD, SE, SG, SK, SL, SY, TJ, TM,
TN, TR, TT, TZ, UA, UG, US, UZ, VC, VN, YU, ZA, ZM,
ZW.

(84) Designated States (*unless otherwise indicated, for every
kind of regional protection available*): ARIPO (BW, GH,
GM, KE, LS, MW, MZ, SD, SL, SZ, TZ, UG, ZM, ZW),
Eurasian (AM, AZ, BY, KG, KZ, MD, RU, TJ, TM), Euro-
pean (AT, BE, BG, CH, CY, CZ, DE, DK, EE, ES, FI, FR,
GB, GR, HU, IE, IT, LU, MC, NL, PT, RO, SE, SI, SK,
TR), OAPI (BF, BJ, CF, CG, CI, CM, GA, GN, GQ, GW,
ML, MR, NE, SN, TD, TG).

Published:

- with international search report
- before the expiration of the time limit for amending the
claims and to be republished in the event of receipt of
amendments

*For two-letter codes and other abbreviations, refer to the "Guid-
ance Notes on Codes and Abbreviations" appearing at the begin-
ning of each regular issue of the PCT Gazette.*

(54) Title: CONVEYING SYSTEM FOR FILLING MULTIPLE STORAGE BINS

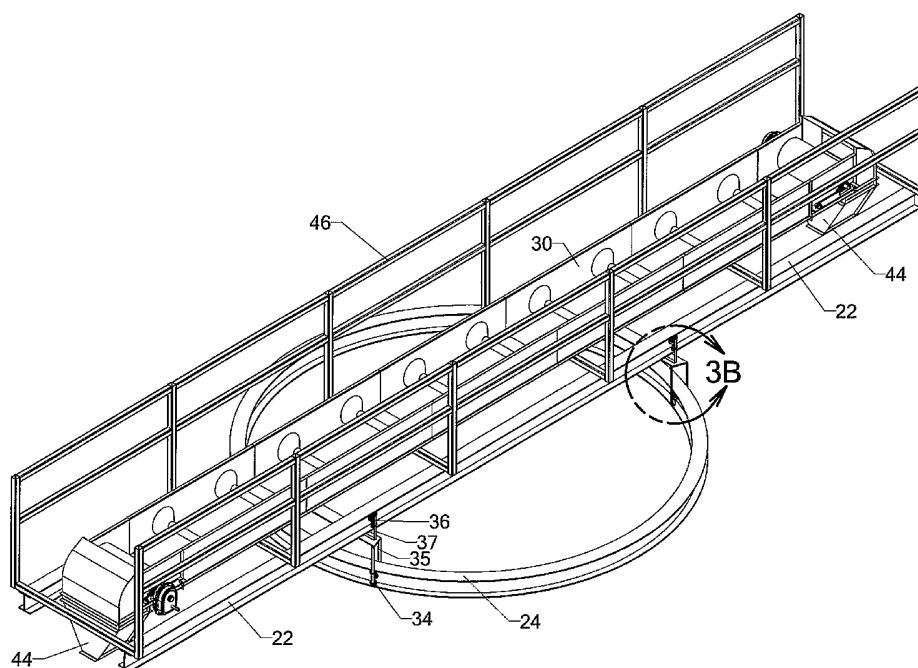

(57) Abstract: A conveying system for distributing material into any bin in a horizontal array of storage bins comprise a circular guide positioned over the array of bins (24), a linear guide (22) that rotates along the circular guide, and a conveyor (30) that is supported by the linear guide. By rotating the linear guide and attached conveyor along the circular guide and by shuttling the conveyor linearly, the conveyor has an infinite number of discharge points to fill any one of the underlying array of bins.

WO 2004/071912 A1

Certification of Express Mailing (37 C.F.R. Section 1.10)

I hereby certify that this Conventional Patent Application is being deposited with the United States Postal Service as "Express Mail Post Office to Addressee" Number ER 516450350 US on the date below in an envelope with sufficient postage addressed to: Commissioner for Patents, PO Box 1450, Alexandria, VA 22313-1450.

Printed or Typed Name: Dwight Eric Kinzer

Signature: _____

Date of Deposit: _____

Patent Application of
Dwight E. Kinzer
for

TITLE: CONVEYING SYSTEM FOR FILLING MULTIPLE STORAGE BINS

CROSS-REFERENCE TO RELATED APPLICATIONS: This application claims the benefit of PPA of Dwight E. Kinzer, Ser. Nr. 60/445,760, filed 5 February 2003.

FEDERALLY SPONSORED RESEARCH: Not applicable

SEQUENCE LISTING OR PROGRAM: Not applicable

BACKGROUND OF THE INVENTION – FIELD OF THE INVENTION

[0001.] This invention relates to distribution systems for filling storage bins, specifically to such systems that fill a plurality of closely-spaced bins.

BACKGROUND OF THE INVENTION – DISCUSSION OF PRIOR ART

[0002.] A significant cost in designing feed mills, grain elevators, and seed conditioning plants, and the like is the distribution system. Facilities such as these typically require many linear meters of conveying equipment. Such equipment can be costly, not only in actual price, but also in terms of maintenance and energy requirements. With the onset of increased purity requirements worldwide, one must also consider cross-contamination issues when choosing methods of distribution. Efficiency and good cleanout, where little or no product remains on the conveyor after it reaches its destination, are two characteristics of conveying systems that are highly desirable in the feed, grain, and seed industries. Current methods of conveying product to bins generally requires a relatively large amount of linear meters of conveyors. Often, the design of a facility's conveying system requires multiple discharge gates, which are sources of cross-

Patent Application of Dwight E. Kinzer for "Conveying System For Filling Multiple Storage Bins" continued

contamination and poor cleanout. Filling an array of bins using conventional methods usually requires many linear-feet of conveying equipment, multiple intermediate discharge gates (which are sources of cross-contamination), and a relatively large amount of energy to run the equipment.

[0003.] Preventing cross-contamination has become a priority in the feed, grain, and seed industries. Cross-contamination issues have become prevalent in recent years due to several factors, such as increased demand for identity preserved traits and the development of genetic engineering to produce genetically modified organisms (GMO). Processors increasingly demand products with characteristics that are best suited for the desired end product. Governments have more strict purity requirements regarding the amount of GMO allowed in Non-GMO products. And consumers desire segregation of GMO from non-GMO products.

[0004.] Mounting international pressure to trace ingredients to points of origin have also contributed to the need to further prevent cross-contamination, and to segregate ingredients. Segregated storage is a concept that is gaining acceptance in the grain and feed industries, since it can enhance value of stored products and help minimize the potential risks associated with foodborne diseases and bioterrorism. Products can be differentiated by such characteristics as the following: (a) ingredient origin, (b) plant variety, (c) protein level, (d) moisture level, (e) quality, (f) particle size, (g) field origin, (i) growing conditions, (k) foreign matter level, or (l) GMO status, for example. Segregated storage and tracing ingredients to their points of origin have recently become even more important in these industries, not only because of regulations put forward by the European Union, but also due to the first documented case of Bovine Spongiform Encephalopathy, or Mad Cow Disease, in the United States. A diseased dairy cow is believed to have contracted the illness from contaminated feed. Efficient segregated storage, aided with a conveying system that greatly reduces or virtually eliminates the chance of cross-contamination, is a fundamental tool in complying with trace-to-origin regulations, and in reducing risks associated with cross-contamination in general.

[0005.] Attempts have been made to reduce the amount of linear meters of conveyor required to fill a plurality of bins. Examples of such conveying systems include those disclosed in US Patent 4,330,232 to McClaren (1982), US Patent 3,197,044 to Hozak (1965), US Patent 4,491,216 to Sawby (1985), US 2003/0113194 to Stafford & Elder (2003), and US Patent 3,435,967 to Sackett (1969).

McClaren attempts to fill a plurality of bins arranged in circular arcs about a central pad.

Patent Application of Dwight E. Kinzer for "Conveying System For Filling Multiple Storage Bins" continued

Limitations of this arrangement include the following: (1) the use of screw conveyors creates cross-contamination issues, since they are not easily completely cleaned of product; (2) rotation is limited by product receiving area requirements; (3) multiple conveyors are needed to reach outlying bins; and (4) the design requires a relatively large footprint, which may be limiting in many facilities.

Hozak's device is somewhat similar to McClaren's, except it uses belt conveyors. In Hozak's design, the system once again requires a relatively large footprint, and as the height of the bins increase, so does the floor space requirement. This system also requires significant space above the bins. Consequently, very tall roofs, known as head houses, would be required if this system were used in enclosed multi-silo structures.

In Sawby's apparatus, a swiveling conveying system with an extendable auger at the end of a boom that pivots around a mast is limited to filling only one arc of receptacles, it requires a large footprint, and cleanout is relatively difficult.

The conveying system disclosed by Sackett is functionally limited to square or rectangular bins, and it requires multiple conveyors.

Stafford and Elder's device requires a large footprint and is limited to one type of structure.

[0006.] Other conventional methods of distributing to multiple silos include belt, drag chain, or screw conveyors. These methods incorporate multiple intermediate discharge gates so the conveyor can discharge at multiple points along the conveyor. The problem with all of these conventional conveyors is that the intermediate discharge gates tend to have carryover problems that can cause potential cross-contamination. If the entire product does not fall through the open intermediate discharge gate, the product can be conveyed to an unintended storage bin. Also, intermediate discharge gates on a conventional conveyor tend to seal imperfectly with the conveyor trough, creating further cross contamination potential.

[0007.] An alternative to using conveying systems, like those described above, is down-spouting. However, down-spouting requires a relatively tall head house, often from about 10 m to 20 m above the bins to be filled. As a result, down-spouted items can reach relatively high speeds, and thus can land harshly within a bin. Such impacts can lower product quality, and so, in many cases, down-spouting is undesirable.

[0008.] In summary, the following are typical disadvantages of conventional conveying

Patent Application of Dwight E. Kinzer for "Conveying System For Filling Multiple Storage Bins" continued

or spouting systems to fill a cluster of bins:

- (a) many linear meters of conveyor are needed, which increases cross-contamination risk and adds to energy and maintenance costs;
- (b) multiple discharge gates are often necessary, which increases risk of cross-contamination;
- (c) multiple motors are usually needed, which adds to energy and maintenance costs; and
- (d) a large footprint is often required.

BACKGROUND OF THE INVENTION – OBJECTS AND ADVANTAGES

[0009.] Accordingly, several objects and advantages of the present invention are:

- (a) to provide an improved conveying system that can fill a plurality of closely-spaced storage bins with minimal linear meters of conveyors, thus lowering associated energy requirements and maintenance costs;
- (b) to provide a conveying system that eliminates a need for multiple discharge openings and intermediate discharge gates, thus reducing risks associated with cross-contamination; and
- (c) to provide a conveying system in which product quality is preserved.

[0010.] Further objects and advantages are to provide a conveying system that is efficient in terms of cost, clean-out, space requirements, energy requirements, and maintenance. The conveying system can also be automated, with electrical location sensors that can position the discharge end(s) of the conveyor at an infinite number of discharge locations, to expand its efficiencies. Still further objects and advantages will become apparent from a consideration of the ensuing description and drawings.

SUMMARY

[0011.] In accordance with the present invention, a conveying system for feeding a plurality of closely-spaced horizontally arrayed storage receptacles with or without shared walls from above comprises a conveyor that is supported by and shuttles along a linear track. The linear track is supported by and rotates along a curvilinear track. The conveyor discharges product into a selected one of a plurality of underlying storage receptacles. The conveying

Patent Application of Dwight E. Kinzer for "Conveying System For Filling Multiple Storage Bins" continued

system provides an infinite number of discharge points.

DRAWINGS – FIGURES

[0012.] Fig 1 is an isometric view of a rotating horizontal conveying system showing an arcuate guiding system and a linear guiding system, in a resting position.

[0013.] Fig 2 shows the conveying system of Fig 1 rotated about 45 degrees and retracted over a selected bin.

[0014.] Figs 3A and 3B show enlargements of the conveyor and dual track system shown in Figs 1 and 2.

[0015.] Fig 4 shows an alternative embodiment which differs from that in Figs 1-3 in that it has multiple concentric arcuate tracks, two linear guiding systems and corresponding conveyors, and a different trolley system.

[0016.] Fig 5 shows an alternative embodiment which differs from that in Figs 1-3 in that linear tracks are suspended from the arcuate track.

Drawings – Reference Numerals

- 20 bin
- 22 linear track
- 24 arcuate track
- 30 conveyor
- 34 first powered truck
- 35 load bar
- 36 second powered truck
- 37 load bar
- 38 wheel
- 40 wheel rod
- 44 discharge end
- 46 catwalk
- 48 column
- 50 column cap
- 52 second conveyor

Patent Application of Dwight E. Kinzer for "Conveying System For Filling Multiple Storage Bins" continued

DETAILED DESCRIPTION – Figs 1, 2, 3A, and 3B: Preferred Embodiment

[0017.] A preferred embodiment of a rotating multiple-track horizontal conveying system of the present invention is shown in an isometric view in Fig 1. Fig 1 shows the embodiment at rest, with an underlying structure comprising multiple bins that are horizontally arrayed. Only top portions of the bin structure is shown, for reference, since virtually any type of well-known multiple bin array configuration can be used. Fig 2 shows the conveying system in a new position, rotated about 45 degrees from its position in Fig 1 and retracted to a selected bin **20** that is ready to be filled. As seen in Figs 1 and 2, the conveying system includes two parallel linear tracks **22** and one arcuate track **24**. In general, the number of concentric arcuate tracks can range from one to several, depending on the type of track used, the weight of items to be conveyed, and the distance that items will be conveyed, as will be discussed elsewhere. Linear tracks **22** preferably support a horizontal belt conveyor **30**, but standard screw or drag types of conveyors can be used. In the example in Figs 1 and 2, powered trucks (trolleys) **34** and **36** support linear tracks **22** above arcuate track **24**. In general, however, linear tracks can be supported above or suspended below the arcuate track or tracks.

[0018.] Linear tracks **22** and arcuate track **24** work in conjunction with each other to position discharge ends **44** over any desired bin within the cluster of bins. Means of powering movement along the tracks are not shown, but I presently prefer one motor for linear movement and another for rotational movement. However, use of power chains and drive motor(s), a hydraulic system, manual rotation and shuttling, or a single motor to move both linearly and rotationally can be alternatively employed. The rotating horizontal conveying system can also be automated (not shown), for example, with electrical location sensors, and/or bin level indicators that indicate when a bin is full. In the example, tracks **22** and **24** are standard monorail I-beam tracks, but any suitable standard track configuration can alternatively be used. For example, flat bar, I-beam, C-beam, double-channel, enclosed tubular, bolted angles, and T-track are suitable for the conveying system, based in part on the weight of items to be conveyed and the distance that items will be conveyed.

[0019.] The diameter of arcuate track **24** as shown in Figs 1 and 2 is about 6.3 m, much smaller than the approximate collective 27.4-m diameter of the bin cluster in the example. Consequently, an assembly for preventing conveyor **30** and linear track **22** from derailing due to severely unbalanced loads can be incorporated. A tri-cam truck/trolley assembly, such as powered trolleys **34** and **36** shown more clearly in Fig 3B, is usually sufficient to prevent such a

Patent Application of Dwight E. Kinzer for "Conveying System For Filling Multiple Storage Bins" continued

calamity. Other trolley assemblies or methods can be engineered to withstand the weight of the equipment and the product being conveyed, while preventing conveyor 30 from tipping off of the track system, by those skilled in the art. For example, conveyor 30 and/or linear tracks 22 can include a cantilever device. Generally, any appropriate radius for arcuate track 24, any suitable trolley assembly, any well-known cantilever system (not shown), and/or multiple concentric arcuate tracks can be used in this conveying system.

[0020.] In the example in Figs 1 and 2, linear tracks 22 are about the same length as conveyor 30, and they are significantly longer than the diameter of arcuate track 24. Alternatively, linear tracks 22 can be significantly shorter than conveyor 30, such that discharge ends 44 of conveyor 30 extend beyond the end of linear tracks 22. In such instances, means to counterbalance the weight of the product being conveyed and the weight of the equipment is employed (not shown). For example, load bar 37 of second powered trucks 36 would be attached directly to conveyor 30 so that conveyor 30 would shuttle directly along linear tracks 22, which would be fixed. Linear tracks 22 would only rotate about arcuate track 24 via first powered truck 34, rather than also translating laterally on second powered trucks 36. This type of situation will be discussed further elsewhere.

[0021.] Catwalk 46 is attached to conveyor 30, for maintenance and service access, and so it also moves with the conveyor, as seen in Figs 1-3. Catwalk 46 is not required when conveyor 30 is easily and safely accessible.

[0022.] Conveyor 30 can be of the standard screw, belt, or drag-chain types. However, belt conveyors provide more complete product cleanout compared to other types of conveyors. Consequently, belt-type conveyors are usually preferable, especially if reducing cross-contamination is a priority. In the example in Figs 1 and 2, the horizontal length of conveyor 30 is slightly less than the collective 13.25-m (about 43.5-ft) radius of the bin cluster. Conveyor 30 is reversible, or bi-directional, in the example, so it has two discharge ends 44. Only one discharge end 44 can be used at a time, since conveyor 30 travels in one direction at a time.

Conveyor 30 can receive product at virtually any point along its length, and it is usually fed from a fixed point. Typically, a fixed vertical conveying system (not shown) transfers product from a receiving area (not shown) to conveyor 30. Conveyor 30 can be fed by a variety of well-known existing vertical-conveying methods, including, but not limited to, the following: (a) a bucket elevator that rises through and is spouted to about the center axis of the arcuate track or tracks, where it discharges onto conveyor 30; (b) a bucket elevator that rises through an offset

Patent Application of Dwight E. Kinzer for "Conveying System For Filling Multiple Storage Bins" continued

location within the cluster of bins and is spouted to conveyor **30**; (c) a bucket elevator that is positioned outside the diameter of the bin cluster and discharges onto a stationary horizontal conveyor, which transfers product to discharge onto conveyor **30**; or (d) a pneumatic conveying system, which uses air pressure, that discharges onto conveyor **30**.

[0023.] In the example in Figs 1 and 2, arcuate track **24** is supported directly by portions of the underlying multiple bin array, namely load-bearing columns **48** with caps **50**. Struts can be added where required (not shown). Other track support means are possible. For example, the tracks can be suspended from above, as will be discussed elsewhere, or supported by other suitable means, such as structural columns, with or without struts, that are independent of the underlying bin array.

In Fig 3A, a first set of powered trucks **34** rotates along arcuate track **24**. A load bar **37** of a second set of powered trucks **34** is oriented perpendicular to a load bar **35** of first powered truck **34**, and attaches to first powered truck **34**. Linear tracks **22** with attached conveyor **30** move along second powered trucks **36**. In a close-up view of Fig 3B (taken from Fig 3A), wheels **48**, rods **50**, and load bars **35** and **37** can be seen more clearly. In this example, each truck **34** and **36** has three wheels **48** with connecting wheel rods **50**. Although a tri-wheel trolley assembly is shown, other known suitable means for allowing movement along the tracks can be used, such as dual-cam assemblies, other wheel configurations, bearings, etc. Powered trucks are used in this preferred embodiment, but other well-known types of trolley systems or movement systems can be used.

[0024.] Thus, only one horizontal conveyor, with infinite discharge points and a minimal amount of linear meters, is needed to fill a plurality of bins; no intermediate discharge gates are required; and overhead space requirements are minimal, usually requiring no more than about 1-2 m (about 3-6 feet).

Operation: Figs 1 And 2

[0025.] In operation, the rotating horizontal conveying system is seen in a resting position in Fig 1, before it is moved to feed the desired bin **20** in Fig 2. In Fig 2, conveyor **30** of Fig 1 is rotated 90 degrees along arcuate track **24**, and conveyor **30** is extended along linear track **22** until discharge end **44** is positioned above bin **20**. Conveyor **30** is now ready to receive product from a feeding conveyor system (not shown). The feeding conveyor system can be of any number of suitable configurations, such as those discussed previously.

Patent Application of Dwight E. Kinzer for "Conveying System For Filling Multiple Storage Bins" continued

[0026.] When using a reversible conveyor, such as the one shown in Fig 1 and discussed previously, conveyor 30 and attached catwalk 46 need rotate only 180 degrees or less to be able to access any given silo within a cluster of silos. If a non-reversible, or uni-directional, conveyor is used, then the conveyor-catwalk assembly will need to rotate about 360 degrees.

Fig 4: Alternative Embodiments -- Multiple Concentric Arcuate Tracks; Multiple Conveyors

[0027.] In an alternative embodiment as shown in Fig 4, concentric arcuate tracks 26 and 28 can be added, if additional support or balancing of linear track 22 or conveyor 30 is needed. Linear tracks 22 extend about the full diameter of outermost concentric arcuate track 28. Powered trucks 34 and 36 of this system are modified so that linear tracks 22 are affixed to load bar 35 of first powered truck 34. Load bar 37 of second powered truck 36 attaches to conveyor 30 (or conveyor 30 with catwalk 46, not shown) so that conveyor 30 (and attached catwalk 46, when required) shuttles along linear tracks 22. As a result, in this embodiment, linear tracks 22 only rotate along arcuate tracks 24, 26, and 28 rather than also translating along second powered trucks 36 as shown in Figs 1 and 2 (previously discussed). Trucks 34 and 36 need not be powered, as in this example. Other well-known trolley or wheel assemblies may be used to achieve rotation and linear movement.

As also shown in Fig 4, more than one horizontal conveyor and linear track system can be incorporated on the same arcuate track system. A second conveyor 52 and its associated embodiments, such as linear track system, catwalk, or both, is arranged in parallel to conveyor 30. Thus, more than one bin can be filled simultaneously.

Fig 5: Suspended from Roof

[0028.] In another alternative embodiment, as shown in Fig 5, arcuate track 24 can be suspended from above, such as from roof rafters (not shown), with linear tracks 22 suspended below arcuate track 24. The arrangement of first powered trucks 34 differs slightly from previously described embodiments in that load bars 35 are inverted, to support second trucks 36, linear tracks 22, and conveyor 30 below arcuate track 24. Such trolley/truck systems can vary according to methods that are well-known to those skilled in the art, and so the embodiment is not limited to the example shown here.

A suspended embodiment, like the one shown in Fig 5, can exist alone or co-exist in the same structure with the preferred embodiment shown in Figs 1 and 2 (not shown). This

Patent Application of Dwight E. Kinzer for "Conveying System For Filling Multiple Storage Bins" continued

alternative embodiment can also be used alone or at the same time as the preferred embodiment previously discussed, to fill more than one bin simultaneously. In such a suspended system, a telescoping spout(s) (not shown) with adequate length to reach underlying bins may be required at discharge end(s) 44 of conveyor 30. The suspended system can be fed by a feeding system that is the same or different from that feeding the first system.

Conclusion, Ramifications, And Scope

[0029.] The present conveying system can be used to fill a plurality of closely-spaced bins from above with maximum efficiency since it provides a means for infinite discharge locations, using only one horizontal conveyor. The need for intermediate discharge gates, which significantly increase risks of cross-contamination, is eliminated. Furthermore, the improved rotating horizontal conveying system has the additional advantages in that it is more economical to build, install, operate, and maintain than conventional conveyor or spouting distribution systems.

[0030.] Although the description above contains many specificities, these should not be construed as limiting the scope of the invention, but as merely providing illustrations of some of the presently preferred embodiments of this invention. Other embodiments are possible. For example, the conveyor can be replaced by other known types of conveyor, such as drag or chain types; and/or other known types of track systems can be used, such as flat bar, I-beam, C-beam, double-channel, enclosed tubular, bolted angles, or T-track; and/or other known types of truck or trolley assemblies can be used. The system can be used to fill a plurality of bins that are of other polygonal shapes, such as square, rectangular, or octagonal. The system can be used to fill a plurality of closely spaced round bins. The arc of the arcuate track can be less than 360 degrees. More than one conveyor and linear track assembly can be used simultaneously on one arcuate track system; and/or more than one arcuate/linear track/conveyor assembly can co-exist to feed multiple bins simultaneously. The conveyor can have telescoping spouts at its discharge ends; it can be non-reversing, having only one discharge end and one tail end; it can incline or decline from horizontal; the system can be automated; and/or the conveyor can be enclosed, with or without telescoping spouts at discharge and/or inlet points; etc. Thus the scope of the invention should be determined by the appended claims and their legal equivalents, rather than by the examples given.

Patent Application of Dwight E. Kinzer for "Conveying System For Filling Multiple Storage Bins" continued

CLAIMS: I claim:

1. A conveyor guidance system for distributing material into a plurality of storage receptacles in a horizontal array, comprising:
 - a substantially horizontally oriented circular guide means supported above said receptacles, said circular guide means having a predetermined diameter;
 - a substantially horizontally oriented linear guide means extending at least the length of said predetermined diameter of said circular guide means and mounted to rotate thereon, and
 - a substantially horizontally oriented conveying means mounted to linear guide means for moving linearly, said conveying means having at least one discharge end,whereby by adjusting said circular guide means and said linear guide means, said conveying means can distribute said material to any of an infinite number of discharge points above said receptacles, with minimal energy inputs and amount of linear meters of horizontal conveyor.
2. The conveyor guidance system of claim 1 wherein said circular guide means comprises at least one circular track, a first trolley means, and a second trolley means, said first and second trolley means each comprising at least one wheel connected to at least one rod, and at least one load bar supporting said rod, said load bar of said first trolley means supporting said second trolley means, said second trolley means being attached substantially perpendicularly to said first trolley means, said load bar of said second trolley means supporting said linear guide means, said first trolley means being movable along said circular guide means, said linear guide means being movable along said second trolley means, and said conveying means being mounted on said linear guide means.
3. The conveyor guidance system of claim 1 wherein said circular guide means comprises at least one circular track and a first trolley means, said first trolley means comprising at least one wheel being connected to at least one rod and at least one load bar supporting said rod and connecting to said linear guide means, said linear guide means being mounted on said load bar of said first trolley means, said linear guide means comprising a second trolley means that moves linearly along said linear guide means, said second trolley means comprising at least one wheel being connected to at least one rod and at

Patent Application of Dwight E. Kinzer for "Conveying System For Filling Multiple Storage Bins" continued

- least one load bar supporting said rod, said conveying means mounting to said load bar of said second trolley means.
4. The conveyor guidance system of claim 1, further including a first control means for achieving rotation of said linear guide system along said circular guide system, and a second control means for achieving linear movement of said conveying means.
 5. The conveyor guidance system of claim 1 wherein said conveying means comprises at least one conveyor, said conveyor being reversible so that either end can serve as a discharge end.
 6. The conveyor guidance system of claim 1 wherein said conveying means comprises at least one conveyor, said conveyor being uni-directional, so that one end serves as a discharge end and the other end serves as a tail end.
 7. A horizontally-oriented, rotating and translating conveying system with an infinite number of discharge points for distributing material to a plurality of horizontally arrayed storage receptacles, comprising:
 - at least one circular guide system having a first trolley means, said circular guide system comprising at least one circular track,
 - at least one linear guide system, said linear guide system mounted on said first trolley means, said linear guide system comprising a plurality of parallel linear tracks and a second trolley means connecting to said parallel linear tracks, and
 - at least one horizontal conveying means mounted on said second trolley means,whereby by adjusting said circular guide means and said linear guide means, said conveying means can distribute said material to any of an infinite number of discharge points above said receptacles.
 8. The conveying system of claim 7 wherein said first and second trolley means comprise wheels with rods, said rods connecting to wheels, said trolley means further comprising load bars, said load bars supporting said rods, said load bar from said first trolley means supporting said linear tracks, said load bar from said second trolley means supporting said conveying means.

Patent Application of Dwight E. Kinzer for "Conveying System For Filling Multiple Storage Bins" continued

9. The conveying system of claim 7, further including a first control means for rotating said linear guide system along said circular guide system, and a second control means for moving said conveying means along said linear guide system.

10. The conveying system of claim 7 wherein said conveyor is reversible so that either end can serve as a discharge end.

11. A conveyor guidance system for distributing material into a plurality of storage receptacles in a horizontal array, comprising:
 - a substantially horizontally oriented circular guide means supported above said plurality of storage receptacles,
 - a substantially horizontally oriented linear guide means supported by said circular guide means,
 - said circular guide means having a predetermined diameter and comprising at least a first trolley means and a second trolley means,
 - said first and second trolley means each comprising at least one wheel connecting with at least one rod, said rod being supported by at least one load bar, said load bar of said second trolley means being attached substantially perpendicularly to said load bar of said first trolley means, said wheels of said second trolley means supporting said linear guide means, said first trolley means being movable along said circular guide means,
 - a substantially horizontally oriented conveying means mounted to said linear guide means, so that said linear guide means and attached said conveying means move linearly along said second trolley means, and
 - said linear guide means rotates along said circular guide means with said first trolley means, whereby by adjusting said circular guide means and said linear guide means, said conveying means can distribute said material to any of an infinite number of discharge points above said receptacles, with a minimal amount of linear meters of horizontal conveyor.

12. The conveyor guidance system of claim 10, further including a first control means for rotating said first trolley means along said circular guide means, and a second control means for moving said linear guide means along said second trolley means.

Patent Application of Dwight E. Kinzer for "Conveying System For Filling Multiple Storage Bins" continued

13. The conveyor guidance system of claim 10 wherein said conveying means comprises a conveyor, said conveyor being reversible so that either end can serve as a discharge end.
14. The conveyor guidance system of claim 10 wherein said circular guide system comprises at least one concentric arcuate track and said linear guide system comprises at least one linear track.
15. A method of filling a plurality of storage receptacles, comprising:
 - (a) providing a substantially horizontally oriented circular guide system,
 - (b) providing a substantially horizontally oriented linear guide system, said linear guide system being mounted to said circular guide system with at least a first trolley means,
 - (c) providing a substantially horizontally oriented conveyor, said conveyor being mounted on said linear guide system,
 - (d) moving said conveyor laterally along said linear guide system, and rotating said linear guide system along said circular guide system, so as to position a discharging end of said conveyor over a selected receptacle from said plurality of storage receptacles.
16. The method of claim 15, further including a horizontal array of storage receptacles positioned under said guide system
17. The method of claim 15 wherein said circular guide system comprises at least one concentric track.
18. The method of claim 15 wherein said linear guide system comprises at least one linear track.
19. The method of claim 15, further including a second trolley means, said second trolley means being fixed to and positioned at about 90 degrees from said first trolley means, said linear guide system being attached to said second trolley means, so that said linear guide means is attached directly to and moves linearly with said conveyor along said second trolley means.
20. The method of claim 15, further including a second trolley means, said second trolley

Patent Application of Dwight E. Kinzer for "Conveying System For Filling Multiple Storage Bins" continued

means being attached to said conveyor, so that said conveyor shuttles along said linear guide means, said linear guide means being attached directly to said first trolley means.

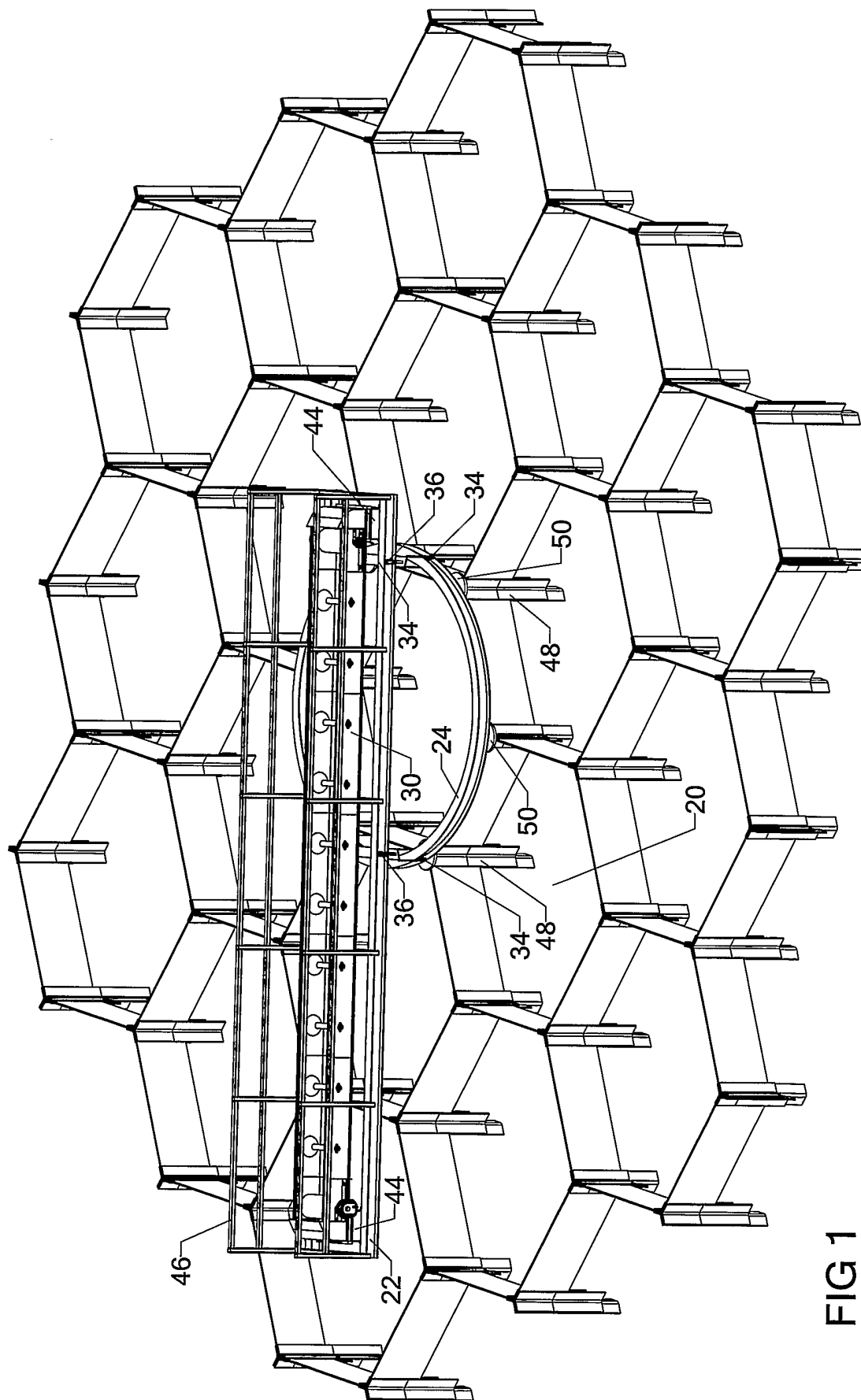

FIG 1

2/5

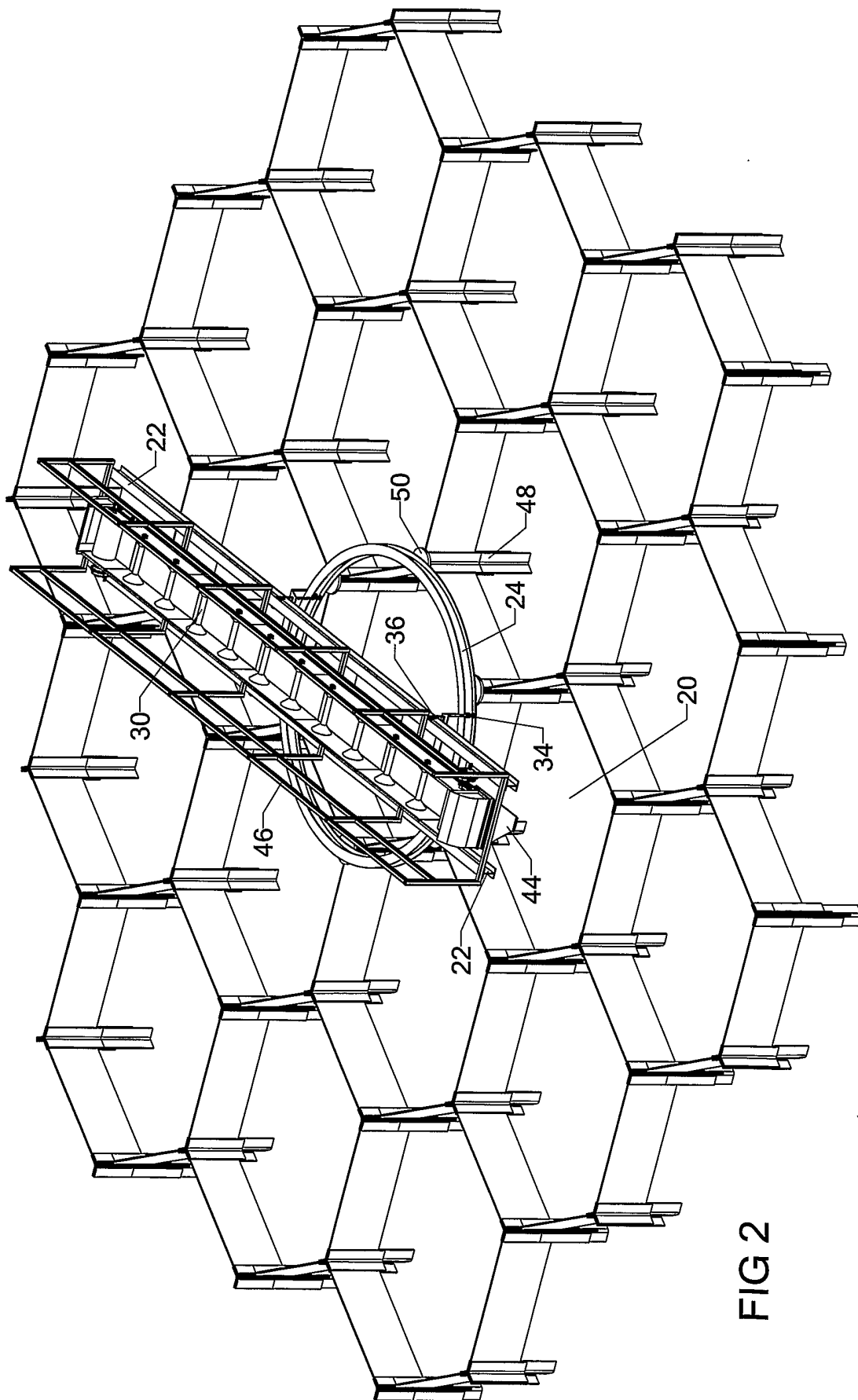

FIG 2

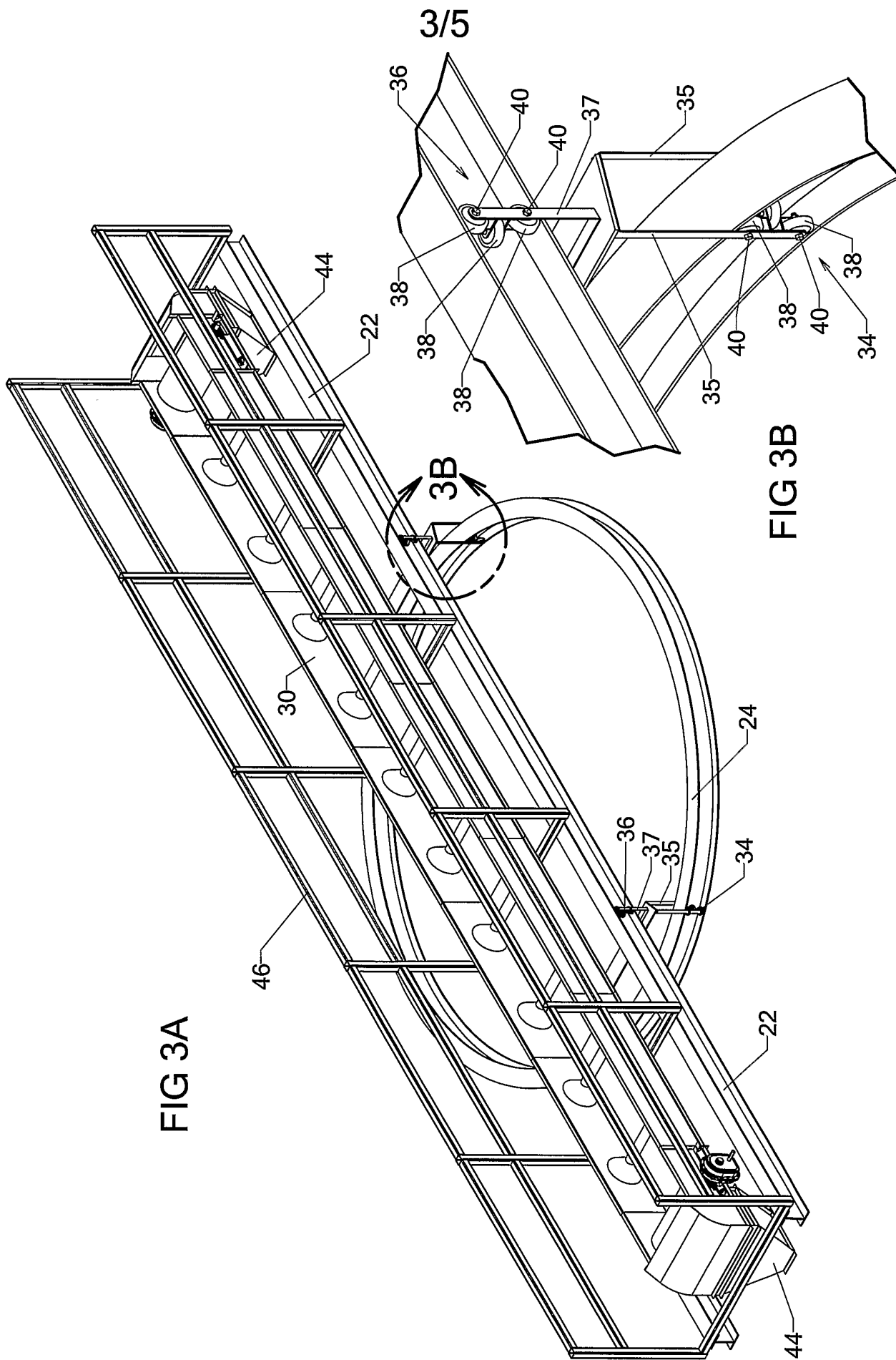
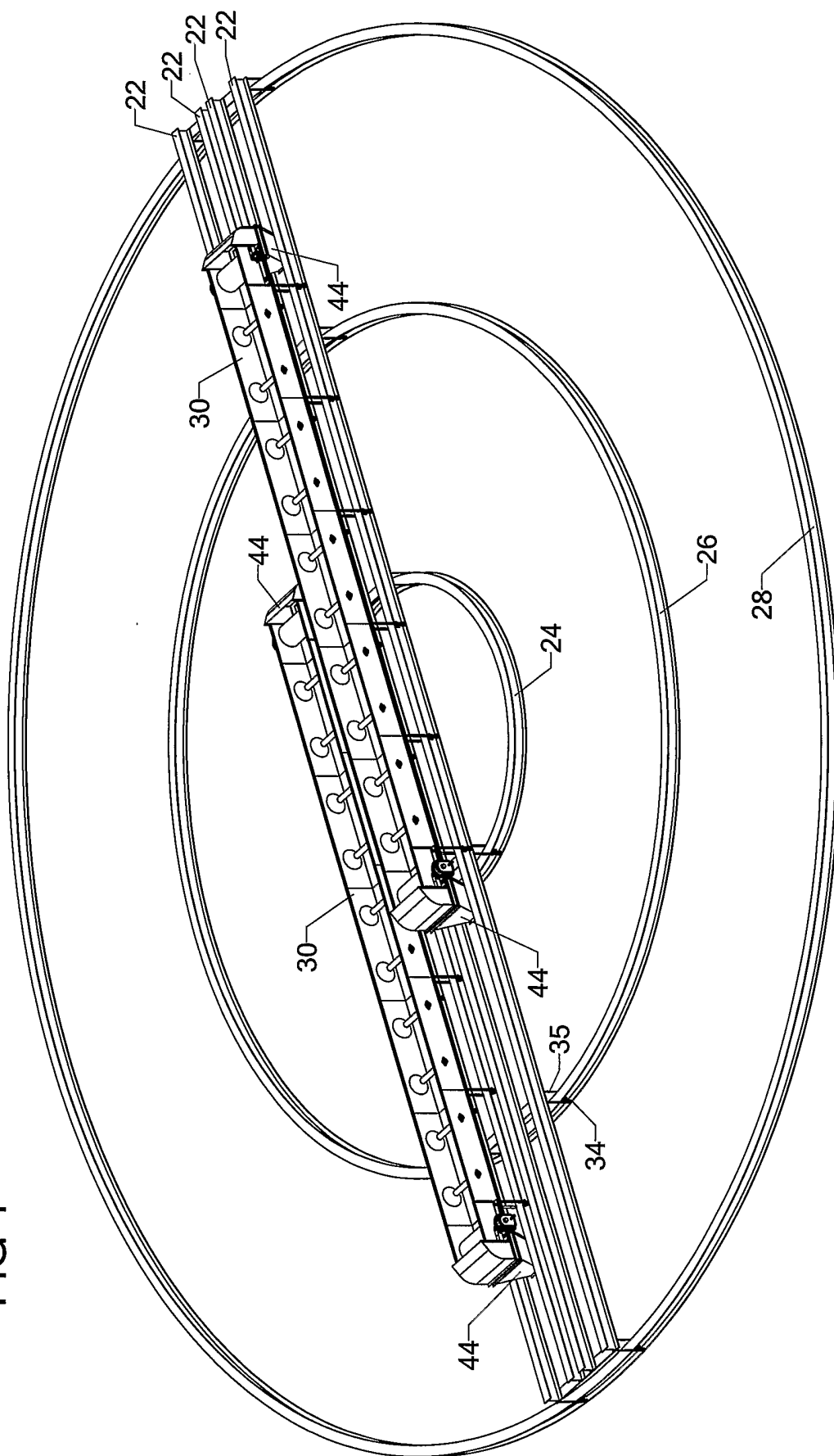

FIG 3A

FIG 3B

3/5

FIG 4



5/5

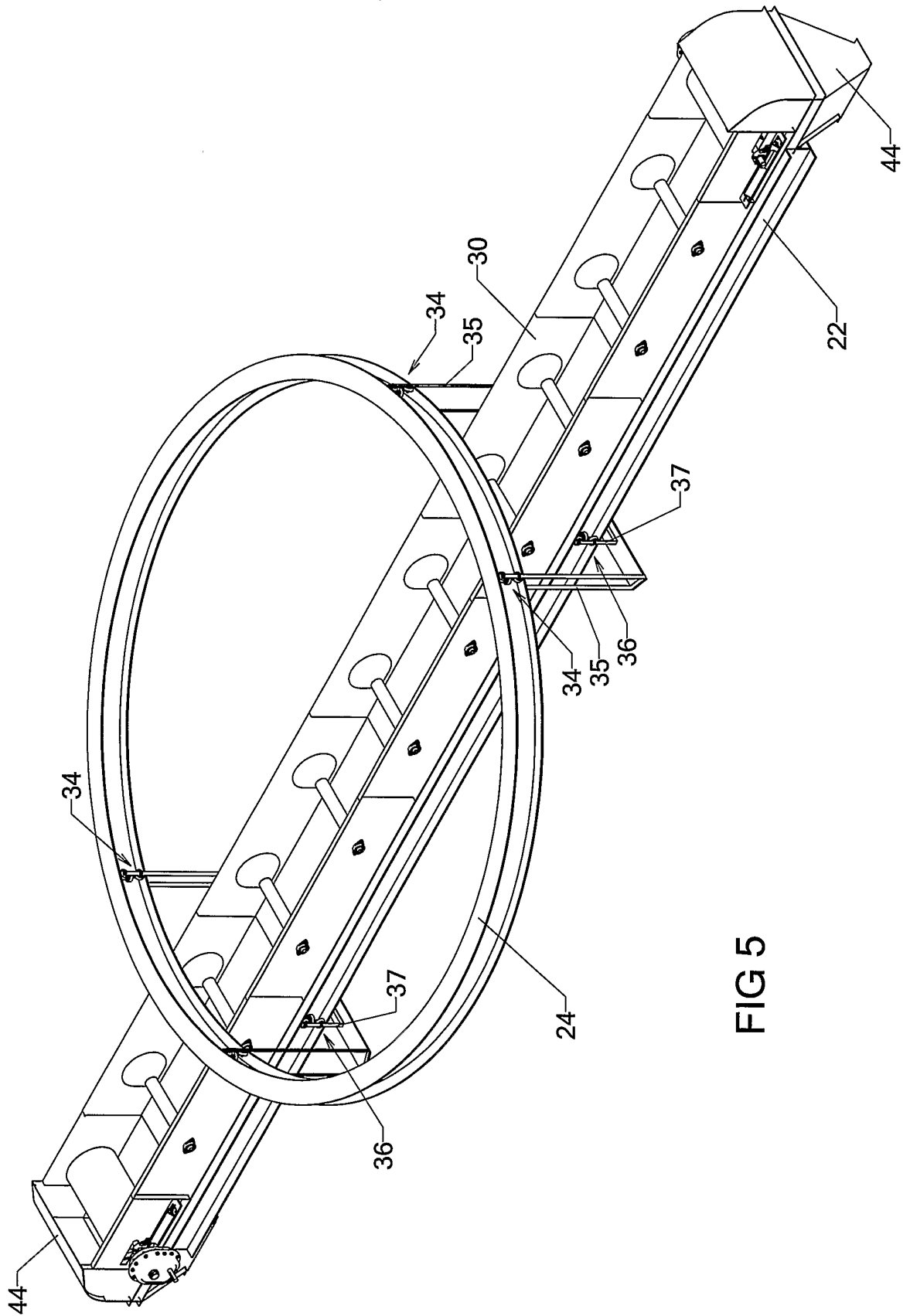

FIG 5

INTERNATIONAL SEARCH REPORT

International Application No PCT/US2004/003214

A. CLASSIFICATION OF SUBJECT MATTER
 IPC 7 B65G65/32 B65G21/12 B65G69/04

According to International Patent Classification (IPC) or to both national classification and IPC

B. FIELDS SEARCHED

Minimum documentation searched (classification system followed by classification symbols)
 IPC 7 B65G

Documentation searched other than minimum documentation to the extent that such documents are included in the fields searched

Electronic data base consulted during the international search (name of data base and, where practical, search terms used)
 EPO-Internal, WPI Data, PAJ

C. DOCUMENTS CONSIDERED TO BE RELEVANT

Category °	Citation of document, with indication, where appropriate, of the relevant passages	Relevant to claim No.
X	DE 270 042 C (MUTH-SCHMIDT MASCHINENFABRIK FÜR GURTFÖRDERER UND TRANSPORTANLAGEN) 12 October 1912 (1912-10-12)	1,6, 15-18
Y	the whole document	3-5, 7-10, 12-14, 19,20
A	-----	2,11
Y	US 2 721 665 A (EBERHARD GOEKE) 25 October 1955 (1955-10-25) column 2, line 19 - column 3, line 38 figures 1-3	3,7,8,20
Y	US 4 619 576 A (GEORGE KURUDAMANNIL A ET AL) 28 October 1986 (1986-10-28) column 5, line 18 - line 31 figures 1-10	4,5,9, 10,12-14
	----- -/--	

Further documents are listed in the continuation of box C.

Patent family members are listed in annex.

° Special categories of cited documents :

- *A* document defining the general state of the art which is not considered to be of particular relevance
- *E* earlier document but published on or after the international filing date
- *L* document which may throw doubts on priority claim(s) or which is cited to establish the publication date of another citation or other special reason (as specified)
- *O* document referring to an oral disclosure, use, exhibition or other means
- *P* document published prior to the international filing date but later than the priority date claimed

- *T* later document published after the international filing date or priority date and not in conflict with the application but cited to understand the principle or theory underlying the invention
- *X* document of particular relevance; the claimed invention cannot be considered novel or cannot be considered to involve an inventive step when the document is taken alone
- *Y* document of particular relevance; the claimed invention cannot be considered to involve an inventive step when the document is combined with one or more other such documents, such combination being obvious to a person skilled in the art.
- * & * document member of the same patent family

Date of the actual completion of the international search

Date of mailing of the international search report

14 July 2004

26/07/2004

Name and mailing address of the ISA

European Patent Office, P.B. 5818 Patentlaan 2
 NL - 2280 HV Rijswijk
 Tel. (+31-70) 340-2040, Tx. 31 651 epo nl,
 Fax: (+31-70) 340-3016

Authorized officer

Papatheofrastou, M

INTERNATIONAL SEARCH REPORT

International Application No

PCT/US2004/003214

C.(Continuation) DOCUMENTS CONSIDERED TO BE RELEVANT

Category °	Citation of document, with indication, where appropriate, of the relevant passages	Relevant to claim No.
Y	GB 752 816 A (HEINZ WILHELM HESSLING) 18 July 1956 (1956-07-18)	19
A	page 1, line 77 - page 2, line 43 figures 1-3 -----	2,11

INTERNATIONAL SEARCH REPORT

Information on patent family members

International Application No

PCT/US2004/003214

Patent document cited in search report	Publication date	Patent family member(s)	Publication date
DE 270042	C	NONE	
US 2721665	A	25-10-1955	NONE
US 4619576	A	28-10-1986	NONE
GB 752816	A	18-07-1956	NONE