

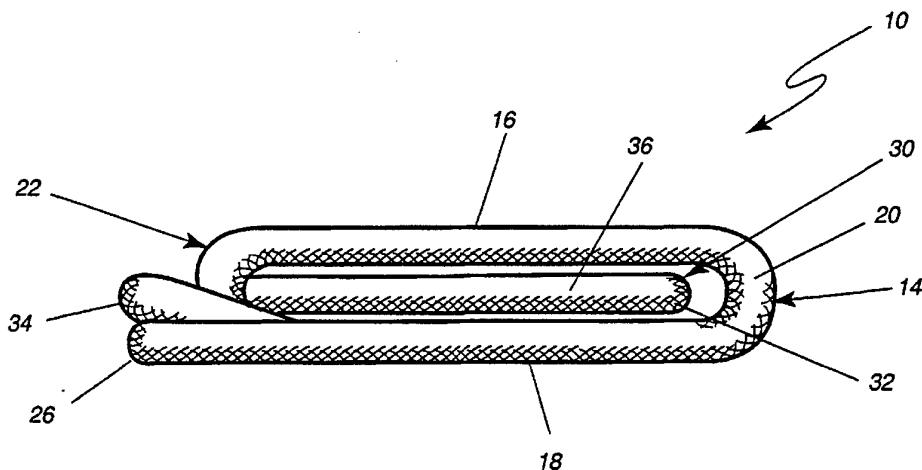

## INTERNATIONAL APPLICATION PUBLISHED UNDER THE PATENT COOPERATION TREATY (PCT)

<p>(51) International Patent Classification<sup>5</sup> : <b>A61B 17/12</b></p>	<p><b>A1</b></p>	<p>(11) International Publication Number: <b>WO 95/05778</b> (43) International Publication Date: 2 March 1995 (02.03.95)</p>
<p>(21) International Application Number: PCT/US94/09326 (22) International Filing Date: 18 August 1994 (18.08.94) (30) Priority Data: 08/111,634 25 August 1993 (25.08.93) US (71) Applicant: LIFE SURGERY, INC. [US/US]; 329 West Lincoln Street, Tullahoma, TN 37388 (US). (72) Inventors: SHIPP, John, I.; 104 Short Springs Road, Tullahoma, TN 37388 (US). CROTHAL, George; 175 Monroe Street, Santa Clara, CA 95059 (US). LATHROP, Robert, L., Jr.; 1667 Glen Rock Court, San Jose, CA 95124 (US). REICHEL, Donald, R.; 15201 Norton Road, Saratoga, CA 95070 (US). (74) Agent: LANQUIST, Edward, D., Jr.; Wadley &amp; Patterson, P.C., 27th floor, L &amp; C Tower, 401 Church Street, Nashville, TN 37219 (US).</p>		<p>(81) Designated States: AU, CA, JP, European patent (AT, BE, CH, DE, DK, ES, FR, GB, GR, IE, IT, LU, MC, NL, PT, SE).  <b>Published</b> <i>With international search report.</i></p>

(54) Title: SURGICAL LIGATION CLIP



## (57) Abstract

A surgical ligation clip (10) is preformed from a continuous piece of metal wire to assume a shape having a reduced cross-sectional area. A clamping arm (30) of the clip is alternately moveable from a clamped to an unclamped position above a vessel support member (14). A tension coil (34) joins the vessel support member to the clamping arm and provides the hemostatic clamping force from the clip to the targeted blood vessel.

**FOR THE PURPOSES OF INFORMATION ONLY**

Codes used to identify States party to the PCT on the front pages of pamphlets publishing international applications under the PCT.

AT	Austria	GB	United Kingdom	MR	Mauritania
AU	Australia	GE	Georgia	MW	Malawi
BB	Barbados	GN	Guinea	NE	Niger
BE	Belgium	GR	Greece	NL	Netherlands
BF	Burkina Faso	HU	Hungary	NO	Norway
BG	Bulgaria	IE	Ireland	NZ	New Zealand
BJ	Benin	IT	Italy	PL	Poland
BR	Brazil	JP	Japan	PT	Portugal
BY	Belarus	KE	Kenya	RO	Romania
CA	Canada	KG	Kyrgystan	RU	Russian Federation
CF	Central African Republic	KP	Democratic People's Republic of Korea	SD	Sudan
CG	Congo	KR	Republic of Korea	SE	Sweden
CH	Switzerland	KZ	Kazakhstan	SI	Slovenia
CI	Côte d'Ivoire	LI	Liechtenstein	SK	Slovakia
CM	Cameroon	LK	Sri Lanka	SN	Senegal
CN	China	LU	Luxembourg	TD	Chad
CS	Czechoslovakia	LV	Latvia	TG	Togo
CZ	Czech Republic	MC	Monaco	TJ	Tajikistan
DE	Germany	MD	Republic of Moldova	TT	Trinidad and Tobago
DK	Denmark	MG	Madagascar	UA	Ukraine
ES	Spain	ML	Mali	US	United States of America
FI	Finland	MN	Mongolia	UZ	Uzbekistan
FR	France			VN	Viet Nam
GA	Gabon				

DESCRIPTION

## SURGICAL LIGATION CLIP

TECHNICAL FIELD

5           The present invention relates generally to mechanical devices used in surgical procedures to obtain ligation or hemostasis, and more particularly, to a ligation clip used during surgery to clamp around a vessel or duct, such as the cystic duct, and thereby obtain ligation.

10           BACKGROUND ART

          It will be appreciated by those skilled in the art that the use of ligation clips to control bleeding during surgical procedures is well known. As described, for example, in U.S. Patent Nos. 4,976,722 and 4,979,950, prior art clips are generally formed of metal wire, usually a titanium alloy, having a "U-shaped" rectangular cross-section. Such prior art clips often include a grooved pattern machined into the inner or clamping surfaces of the clip, in an attempt to enhance the ability of the clip to remain in position after it is closed around the vessel. Application of the clip to the vessel is normally effected by means of a crushing action produced by a clip applier, such as that disclosed in U.S. Patent No. 5,030,226. Such crushing actions, of course, permanently deform the clips, making them difficult to remove or re-position.

          Prior art surgical ligation clips have several inherent problems. For example, the force applied by the clip to the vessel can be variable and inconsistent from one clip to the next, because of the variation in crushing force applied to the clip by the user. Further, prior art clips have a tendency to slip off the end of the blood vessel stub to which it has been applied, because of the low coefficient of friction associated with the clip, and lack of adequate restraining force provide by the clip. Because of this, separation of the clip from the vessel to which it has been applied, after the wound has been closed, is not uncommon.

          It is also common in the prior art to actually form and crush the clip only at the time of its application to the targeted blood vessel. Accordingly, the clip applier mechanism must be relatively large and cumbersome. This is a particular problem in laparoscopic procedures, during which both the clip and clip applier must be inserted through a trocar placed through the patient's external tissues and into the surgical field.

Thus, prior art ligation clips used in laparoscopic procedures universally consist of a 10 mm diameter clip applier that can fit only through a trocar having a 10 to 11 mm diameter entry port. Because one goal of laparoscopic surgery is to minimize the size of the entry wound, a surgical ligation clip and clip applier that can be used within a  
5 5 mm diameter trocar port is highly desirable.

What is needed, then, is a surgical ligation clip that can be easily pre-formed into a shape that presents a minimal cross-sectional area, that can be easily applied to a vessel and that, when applied, will impart a consistent hemostatic force to the vessel while resisting separation from the vessel stub. This device is presently lacking in the  
10 prior art.

#### DISCLOSURE OF THE INVENTION

In order to achieve the objects of simplicity of manufacture, ease of use, consistency of clamping force, high resistance to lateral slippage, and presentation of  
15 minimal cross-sectional area during placement of the clip into the surgical field, a new and improved surgical clip was designed having a vessel clamping arm, a vessel support member, and a tension coil integrally joining the arm and support member. The clip is pre-formed so that in its relaxed state, it can be easily placed within the surgical field, including through a endoscopic trocar port with as little as a five millimeter  
20 diameter. After the clip is placed proximate the blood vessel or duct to be clamped, the clamping arm is moved from its relaxed position to a position under tension, allowing positioning of the vessel between the arm and support member. When correct placement and positioning is achieved, the arm is released and, as the arm tends to move back towards its relaxed position, it clamps the vessel between the arm's curved  
25 lower surface and the supporting upper surface of the vessel support member.

To enhance the performance of the tension coil, in a preferred embodiment of the invention, the vessel support member includes first and second arms, one of which terminates in a loop section. Minimal cross-sectional area of the clip is achieved by substantially longitudinally aligning the vessel support member, the clamping arm, the  
30 loop section, and the tension coil.

In a first embodiment of the clip, the clamping arm is pre-formed into a relaxed

position whereby it extends slightly below the horizontal plan of the support member. A second embodiment of the clip preloads the clamping arm into a relaxed position where the free end of the arm rests against the upper surface of the support member.

Fig. 1 is a top view of the surgical clip of the present invention with the vessel clamping member in a relaxed position.

Fig. 2 is a side view of the surgical clip of the present invention with the vessel clamping member in a relaxed position.

Fig. 3 is a top view of the surgical clip of the present invention after application to a blood vessel and with the vessel clamping arm in a clamped position.

Fig. 4 is a side view of the surgical clip of the present invention after application to a blood vessel, showing the vessel clamping arm in a clamped position.

Fig. 5 is a top view of a second embodiment of the surgical clip of the present invention having a preloaded clamping arm.

Fig. 6 is a side view of a second embodiment of the surgical clip of the present invention.

Fig. 7 is a top view of a third embodiment of the surgical clip of the present invention.

Fig. 8 is a side view of a third embodiment of the surgical clip of the present invention.

Fig. 9 is an end view of a third embodiment of the surgical clip of the present invention.

Fig. 10 shows the surgical clip within the jaws of a clip grasper/applier.

#### BEST MODE FOR CARRYING OUT THE INVENTION

Looking first at Figs. 1 and 2, the surgical ligation clip of the present invention is shown in its relaxed position, prior to its manipulation into a position around the target blood vessel. Surgical clip 10 comprises generally a blood vessel clamping arm 30 which is moveable in a plane perpendicular to blood vessel support member 14. As seen best in Fig. 1, support member 14 is formed of a continuous piece of surgical wire, such as titanium or stainless steel, which is bent to define a first arm 16 and a

substantially parallel second arm 18 joined by a one hundred eighty degree (180°) bend section 20. In the preferred embodiment, the proximal free end 24 of clip 10 will be joined to first arm 16 of support member 14 by a ninety degree (90°) bend section 22.

Second arm 18 terminates at its proximal end (away from one hundred eighty (180°) bend section 20) in loop section 26, the plane of which is perpendicular to the plane of support member 14 and which loops inwardly toward clamping arm 30.

In its relaxed position as shown in Figs. 1 and 2, clamping arm 30 is longitudinally aligned with and oriented between first arm 16 and second arm 18 of support member 14, but below the horizontal plane defined by first and second arms 16 and 18. The distal free end 32 of clip 10 defines the beginning of clamping arm 30. A curved section 36 of clamping arm 30 moves proximally away from free end 32, terminating in tension coil 34. The vertical plane established by tension coil 34 is oriented in substantial alignment with the vertical plane of loop section 26, and, accordingly, perpendicular to the horizontal plane of support member 14. It will be apparent to those skilled in the art that in this orientation, and by forming clip 10 of a continuous piece of resilient material, movement of clamping arm 30 will place clamping arm 30 under tension with respect to vessel support member 14. Further, such an orientation will minimize the width and cross-sectional area of clip 10 which is preferred, particularly in laparoscopic surgery.

Looking now at Figs. 3 and 4, application of clip 10 to a blood vessel 40 to achieve hemostasis is shown. After clip 10 is placed in the surgical field adjacent to the targeted blood vessel 40, clamping arm 30 is moved upwardly between vessel support member arms 16 and 18 to define a gap and space between distal free end 32 and the upper surface of one hundred eighty (180°) bend section 20. For most uses, a vertical gap of approximately 1.5 mm will be sufficient. Clip 10 is then maintained in this position so that blood vessel 40 can be manipulated within the space created between arm 30 and support member 14. Clamping arm 30 is then released, trapping vessel 40 within clip 10 as arm 30 moves toward its relaxed position. The curvature of curved section 36 of clamping arm 30 causes a relatively consistent clamping pressure to be placed over the entire surface of vessel 40, thereby achieving effective hemostasis. By placing loop section 26 physically adjacent to, and operatively in series

with tension coil 34, a smoother, more consistent application of hemostatic force is obtainable, while increasing the resistance of clip 10 to deformation.

It will be apparent to those skilled in the art that clip 10 is also effective in clamping off ducts connecting various organs, the cystic duct for example. Accordingly, where the term "vessel" is used herein, it is intended that such reference include all fluid carrying body structures within the surgical field where ligation or clamping is needed. Where the diameter of a duct or other structure to be clamped is substantially larger than 1.5 mm, a slightly modified method of applying clip 10 is preferred so that the elastic limit of the material used in the construction of clip 10 is not exceeded. In such modified technique, surgical pliers of conventional design are first positioned over the area to be clamped and the duct or other structure is then compressed to approximately a two wall thickness, or 1.5 mm. The pliers are then removed and clip 10 applied as described above. To minimize the risk of over-compression, the pliers (not shown) will preferably include a means for limiting closure of its jaws to a minimum spacing of approximately 1.5 mm. The use of this technique on large structures allows clip 10 to be formed with a minimized profile suitable for use in a 5 mm trocar, even if the diameter of the duct to be clamped, for example, exceeds 5 mm.

To remove or re-position clip 10, clamping arm 30 needs merely to be moved back up into its fully unclamped position, the vessel and clip manipulated as needed, and then clamping arm 30 is released towards its relaxed position.

To counteract the tendency of clip 10 to produce a torsional force to blood vessel 40, it is preferred that the proximal free end of 24 of clip 10 join a ninety degree (90°) bend section 22 interposed between arm 16 and proximal free end 24. As shown on Fig. 2, free end 24 and a segment of bend section 22 is centrally disposed within tension coil 34.

Adding a series of ridges, notches, burrs by machining, etching, or other treatment to the clamping surfaces of arm 30 and support member 14 can enhance the gripping force of clip 10.

To achieve the objective of minimizing the cross-sectional area of clip 10, thereby permitting it to be used in laparoscopic surgical procedures, clip 10 is pre-

formed into the position substantially as shown on Figs. 1 and 2. In this configuration, arms 16 and 18, clamping arm 30, tension coil 34, and loop section 26 are in substantially alignment longitudinally.

In a preferred embodiment of the clip of the present invention, adaptable for placement within an endoscopic surgical field through a 5 mm diameter trocar port, the inside diameters of tension coil 34 and loop section 26 are approximately 3 mm. The length of clip 10, measured from the proximal surface of tension coil 34 to the distal surface of one hundred eighty (180°) degree bend section 20 is approximately 12 mm. The width of vessel support member 14, measured at the outside surfaces of first arm 16 and second arm 18, is approximately 2.5 mm. Clamping arm 30 is approximately 9 mm from distal free end 32 to its intersection with tension coil 34. In the preferred embodiment, curved section 36 of clamping arm 30 will have a radius of curvature of approximately 25 mm. A suitable material from which clip 10 can be formed is wrought titanium 6A1-4V ELI alloy wire having a nominal diameter of 0.75 mm, and which meets ASTM Standard F136-92. Clip 10 can also be made of wire having a non-circular cross section, or formed from wire having a combination of circular and non-circular sections. For example, tension coil 34 and/or clamping arm 30 could be stronger if formed from rectangular-shaped wire.

A second embodiment of clip 10 is shown in Figs. 5, 6, and 7, with the essential difference from the first embodiment being an extension of clamping arm 30 so that in its "relaxed" position, arm 30 rests in a preloaded condition on the upper surface of support member 14, at bend section 20. Accordingly, a preferred length of arm 30 in this embodiment is approximately 7.3 mm with an overall length of clip 10 of approximately 11.4 mm. By extending and preloading arm 30 so that it can assume the position shown in Fig. 6, the cross-sectional area presented by clip 10 is further minimized, rendering it more adaptable for use in small diameter trocars. Preloading arm 30, of course, helps to maintain clip 10 in a narrow profile until it is positioned for application.

As seen in Fig. 6, first arm 16 and second arm 18 of support member 14 are curved upwardly to enhance the clamping force distribution characteristics of clip 10. It will be apparent to those skilled in the art that, as in the first embodiment of Figs.



1-4, such curvature could be provided alternatively or additionally within clamping arm 30. Where ease of manufacture is a prime objective, each of arms 15, 18, and 30 can be straight.

5 A third embodiment of the surgical clip 10 of the present invention is shown in Figs. 7, 8, and 9. Clamping arm 30 has a curved section 36 extending between distal free end 32 and tension coil 34. Vessel support member 14 is continuously formed of a first arm 16 terminating at proximal free end 24, joined to second arm 18 by one hundred eighty degree (180°) bend section 20. Preferably, bend section 20, as shown in Fig. 9, will also have a generally concave shape so the clamping forces will be distributed more evenly across the surface of the blood vessel (not shown). The shape of curved section 36 of vessel clamping arm 30 is generally convex to provide a more secure holding force to the vessel as well. Although tests have shown that the second embodiment does not perform as well as the first embodiment described above, it does offer the advantage of being simpler to pre-form and perhaps to apply.

10  
15  
20  
25  
30  
Fig. 10 conceptually illustrates the jaw end of a surgical grasper tool 40 which has been modified to function as a clip applier for the surgical clip of the present invention. Slots (not shown) have been machined into the opposing horizontal surfaces of upper jaw 41 and lower jaw 42 to accommodate therein segments of tension coil 34 and loop section 26, thereby orienting clip 10 in the vertical plane. Retaining pins 44 extend perpendicularly from the vertical surfaces of upper jaw 41. A tooth 43 is attached to the vertical surface of lower jaw 42 and extends above jaw 42. When clip 10 is in proper position for application, pins 44 are in contact with tension coil 34 and tooth 43 is in contact with clamping arm 30. Consequently, when jaws 41, 42 are moved toward each other (by operation of the grasper handle, not shown), pins 44 bear against tension coil 34, and tooth 43 causes clamping arm 30 to move upwardly from its relaxed position. This creates a gap between the free end 32 of arm 30 and the upper surface of support member 14. Clip 10 can then be positioned around the blood vessel (not shown). When jaws 41, 42 are then allowed to move apart, clamping arm 30 is forced downward by tension coil 34 into a clamped position around the vessel. To remove or re-position clip 10, graspers 40 are re-positioned as shown in Fig. 9 and the process is repeated.

5 Thus, although there have been described particular embodiments of the present invention of a new and useful surgical ligation clip, it is not intended that such references be construed as limitations upon the scope of this invention except as set forth in the following claims. Further, although there have been described certain dimensions used in the preferred embodiment, it is not intended that such dimensions be construed as limitations upon the scope of this invention except as set forth in the following claims.

CLAIMS

What I claim is:

5 1. A clip for producing hemostasis in a blood vessel located in a surgical field, said clip comprising clamping means for applying a hemostatic force to said blood vessel, said clamping means adjustable between a clamped position and at least one unclamped position while within said surgical field.

2. The clip of Claim 1 wherein said clip is pre-formed to assume said clamped position prior to placement of said clip in said surgical field.

10 3. The clip of Claim 1 wherein said clip is pre-formed to assume said unclamped position prior to placement of said clip in said surgical field.

4. The clip of Claim 1, wherein said clamping means comprises a vessel clamping arm joined to a vessel support member.

5. The clip of Claim 4 further comprising integral tension means to generate said hemostatic force when said clamping means is in said clamped position.

15 6. A surgical ligation clip comprising:  
a. an arm for clamping a blood vessel;  
b. a blood vessel support member connected to said clamping arm;  
c. said clamping arm moveable between a relaxed first unclamped position, a second unclamped position, and a clamped position intermediate said first and second unclamped positions; and

20 d. means to generate and apply a hemostatic force to said blood vessel when said clamping arm is in said clamped position.

25 7. The clip of Claim 6, said hemostatic force generation and application means comprising a tension member attached between said clamping arm and said vessel support member.

8. The clip of Claim 7 wherein said tension member comprises a tension coil connecting one end of said clamping arm to said vessel support member.

9. The clip of Claim 8 wherein said clamping arm, said tension member, and said vessel support member comprise a pre-formed continuous length of material.

30 10. A surgical ligation clip comprising an arm for clamping a blood vessel, said arm pre-formed into a relaxed position in which said arm is substantially aligned

with an integrally pre-formed vessel support member, and said arm moveable under tension to a position above said support member whereby said blood vessel can be positioned between said clamping arm and said support member, and whereby said clamping arm applies a hemostatic force to said blood vessel when said clamping arm is released toward said relaxed position.

5 11. The clip of Claim 10, said clamping arm comprising a free end joined to a first end of a tension coil by a curved clamping section.

10 12. The clip of Claim 11, said vessel support member comprising a first arm joined to a second arm by a 180 degree bent section creating a gap between said first and second arms, said second arm joined to a second end of said tension coil, and said clamping arm moveable in said gap between said first and second arms.

13. The clip of Claim 12, said vessel support member further comprising a loop section between said second arm and said tension coil.

15 14. The clip of Claim 13, said vessel support member first and second arms, said clamping section, said tension coil, and said loop section being in substantial longitudinal alignment, whereby a minimum cross-sectional area is presented during insertion of said clip into a surgical field.

20 15. The clip of claim 14 wherein when said clamping arm is pre-formed in said relaxed position, said arm is in a preloaded condition with said free end of said clamping arm resting above and against said support member.

16. The clip of Claim 15 further comprising means for preventing torsional movement of said blood vessel when said clip is applied.

17. The clip of Claim 16, said torsional movement prevention means comprising a 90 degree bent section joined to the free end of said first arm.

25 18. A method of achieving hemostasis of a blood vessel during surgery comprising the steps of:

a. placing a pre-formed surgical ligation clip having a clamping arm and a vessel support member proximate said vessel;

30 b. bending said clamping arm away from said vessel support member, thereby placing said clamping arm under tension;

c. placing said clip around said vessel, whereby said vessel is positioned

between said arm and said support member; and

d. releasing said clamping arm, thereby placing said vessel under tension between said arm and said support member.

5 19. The method of Claim 18 wherein said pre-formed clip is placed proximate said blood vessel by manipulating said clip through a trocar.

20. The method of Claim 19 wherein said trocar has an inner diameter of approximately 5 mm.

21. The method of Claim 18 further comprising the step of compressing said vessel to a reduced diameter prior to placing said clip around said vessel.

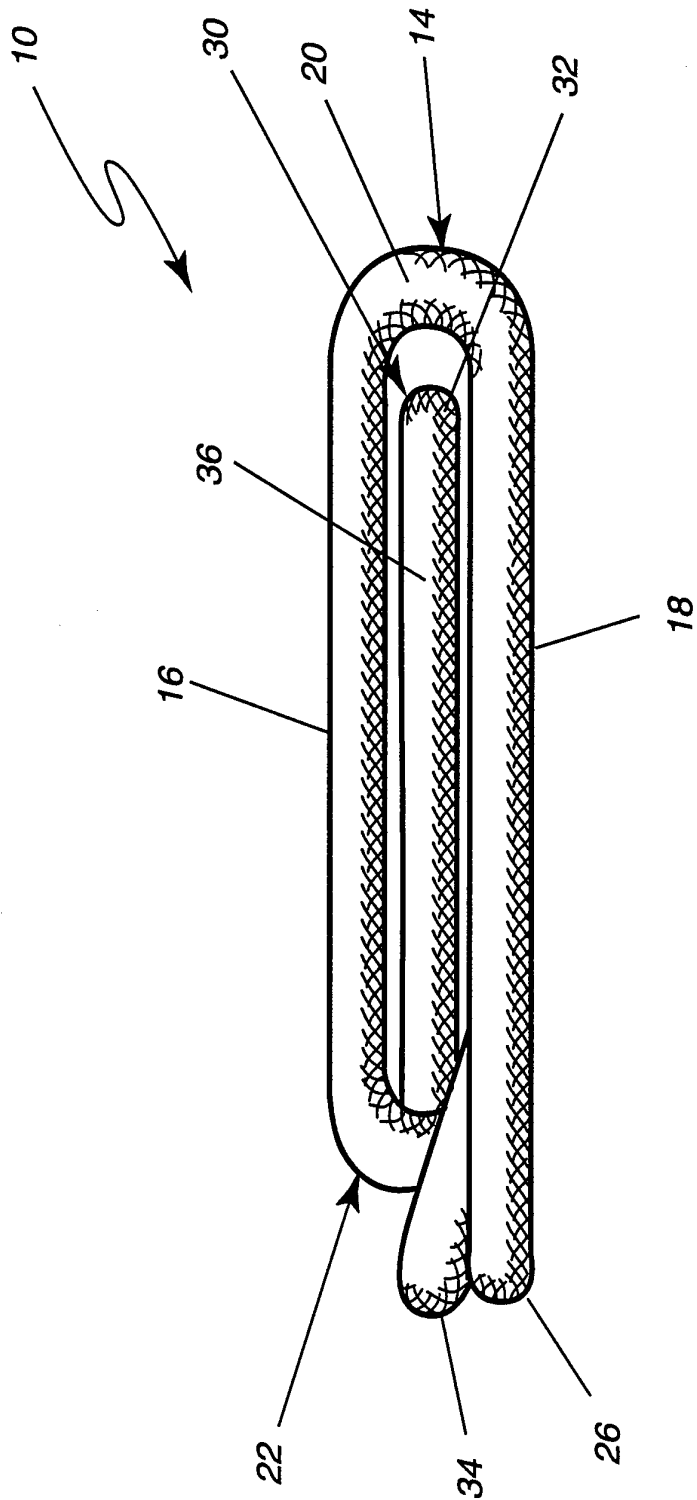
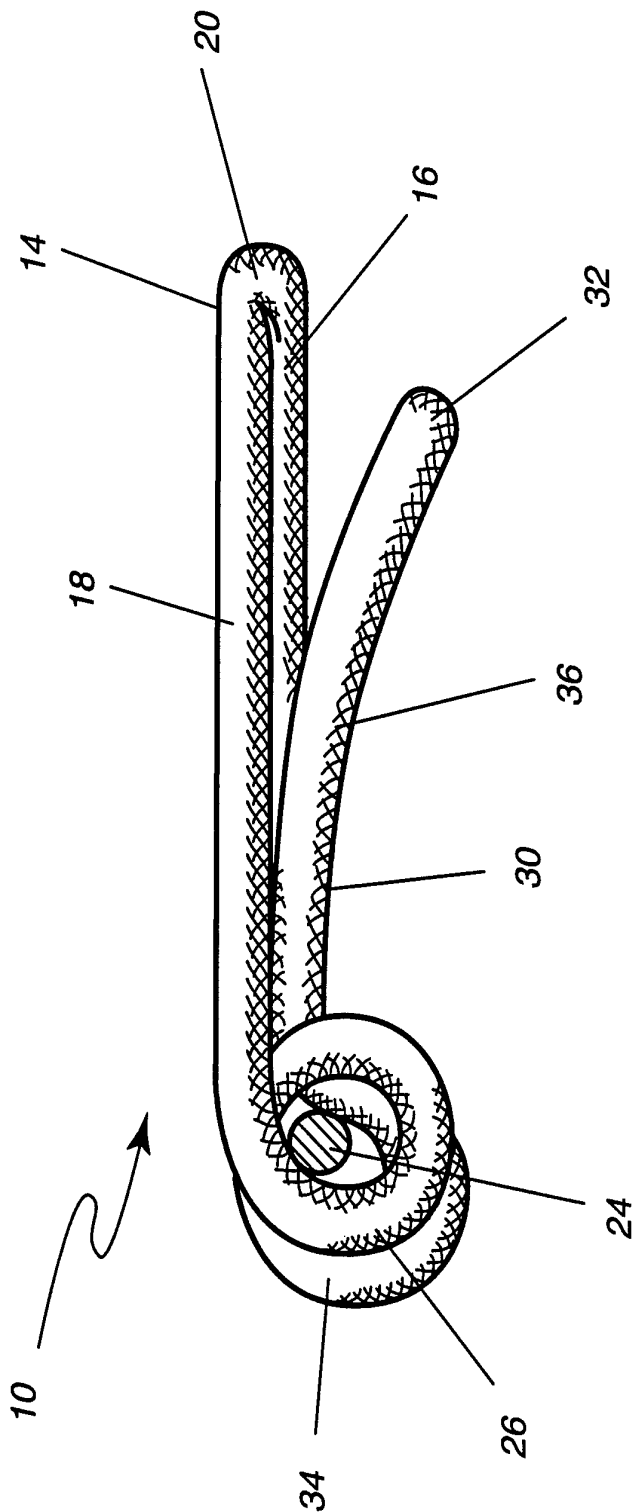

FIG. 1



**FIG. 2**

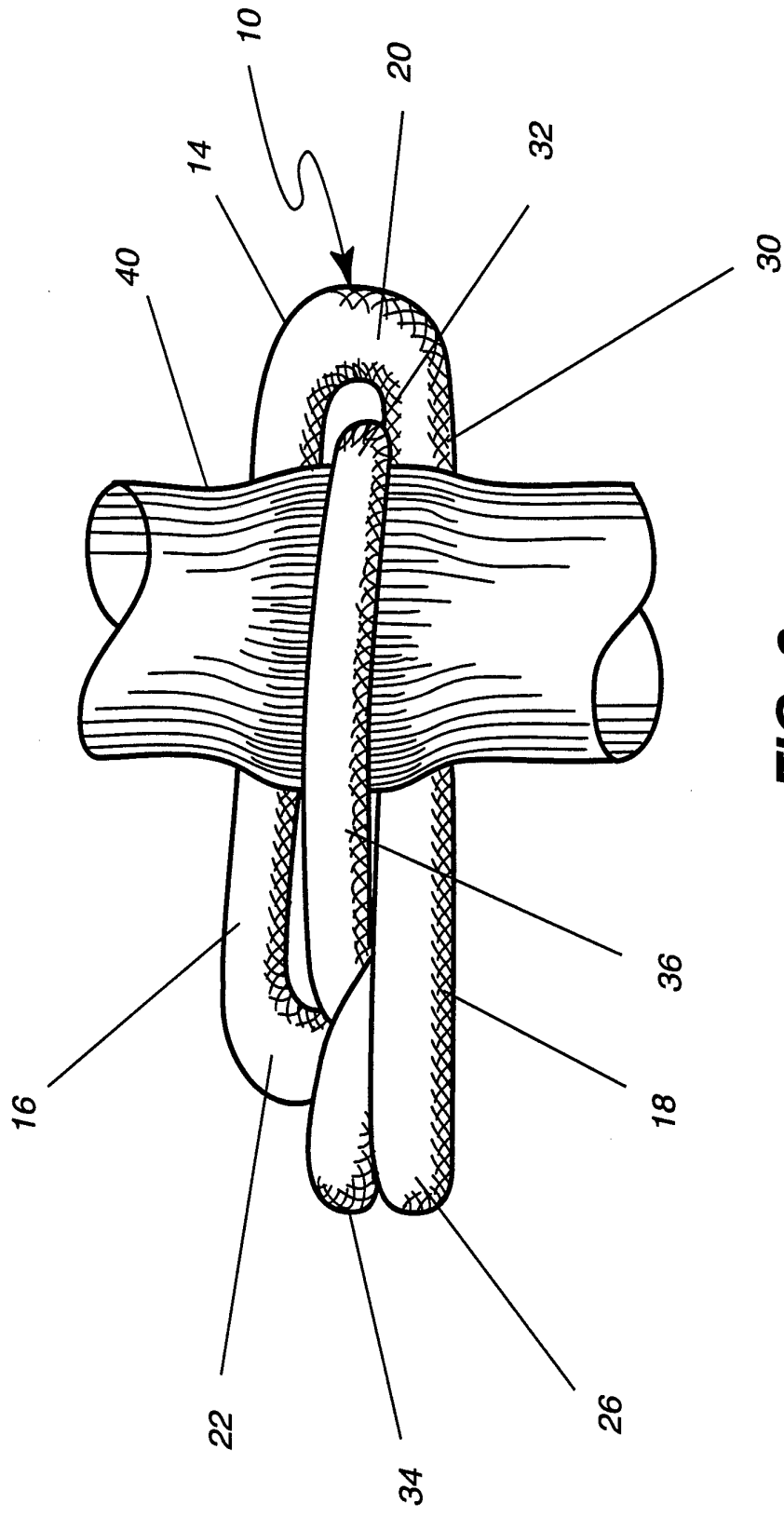

FIG. 3



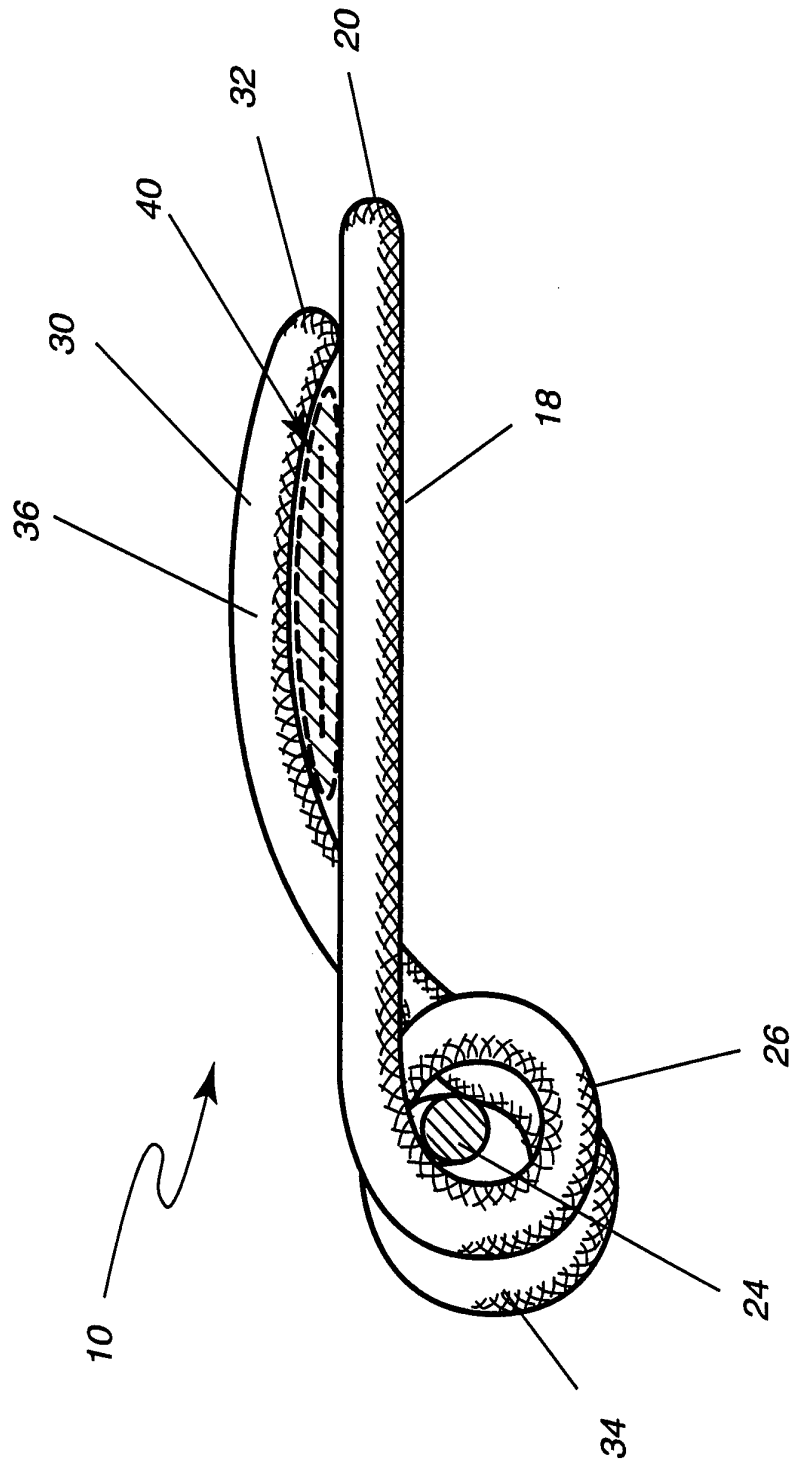
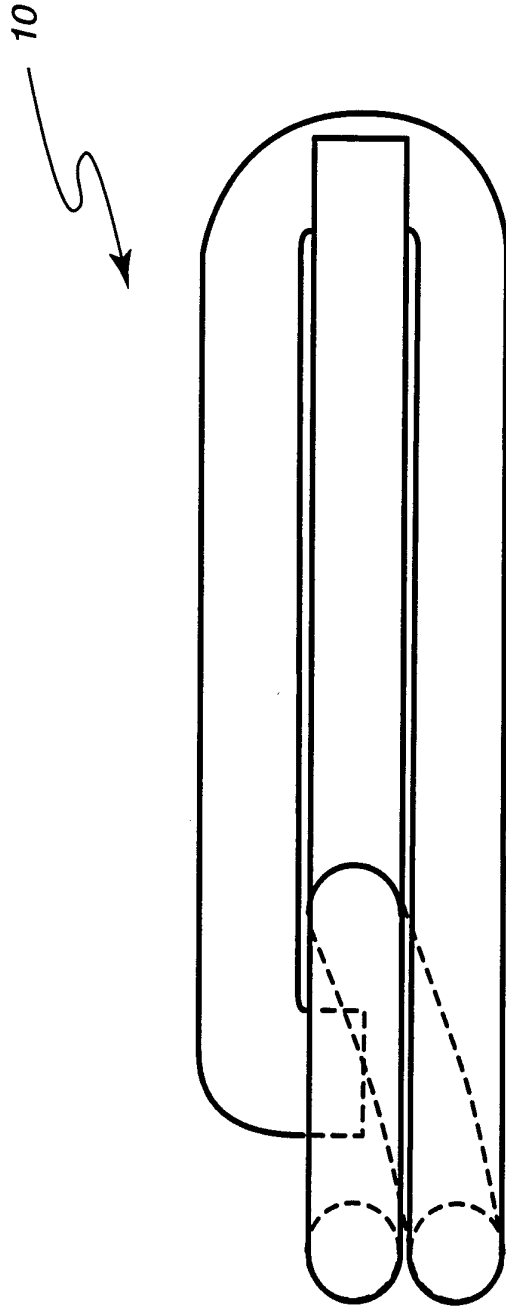
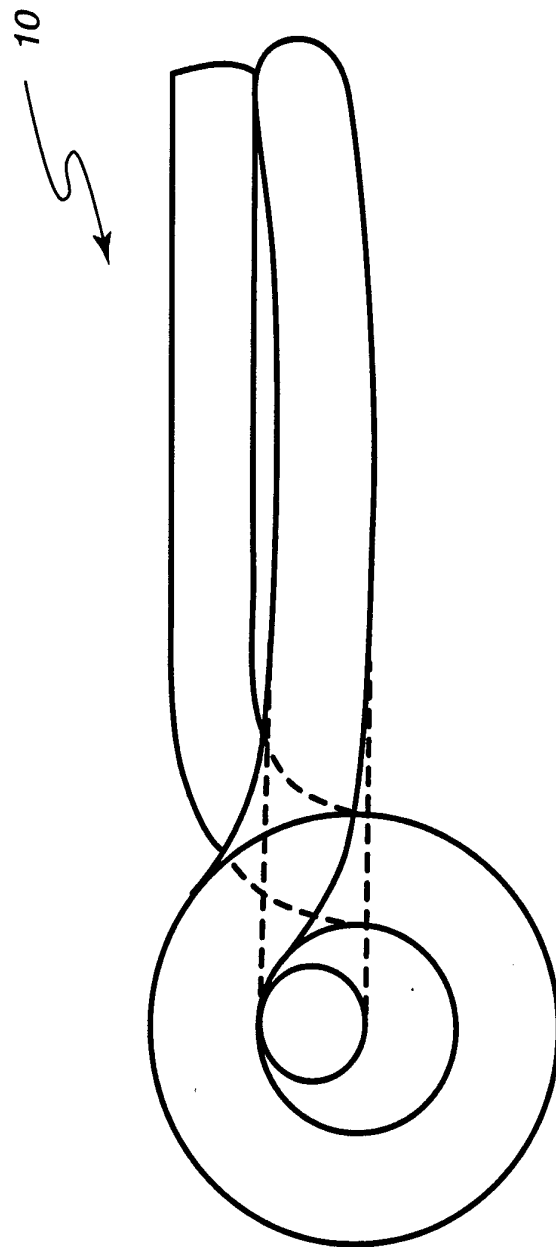

FIG. 4



**FIG. 5**



**FIG. 6**

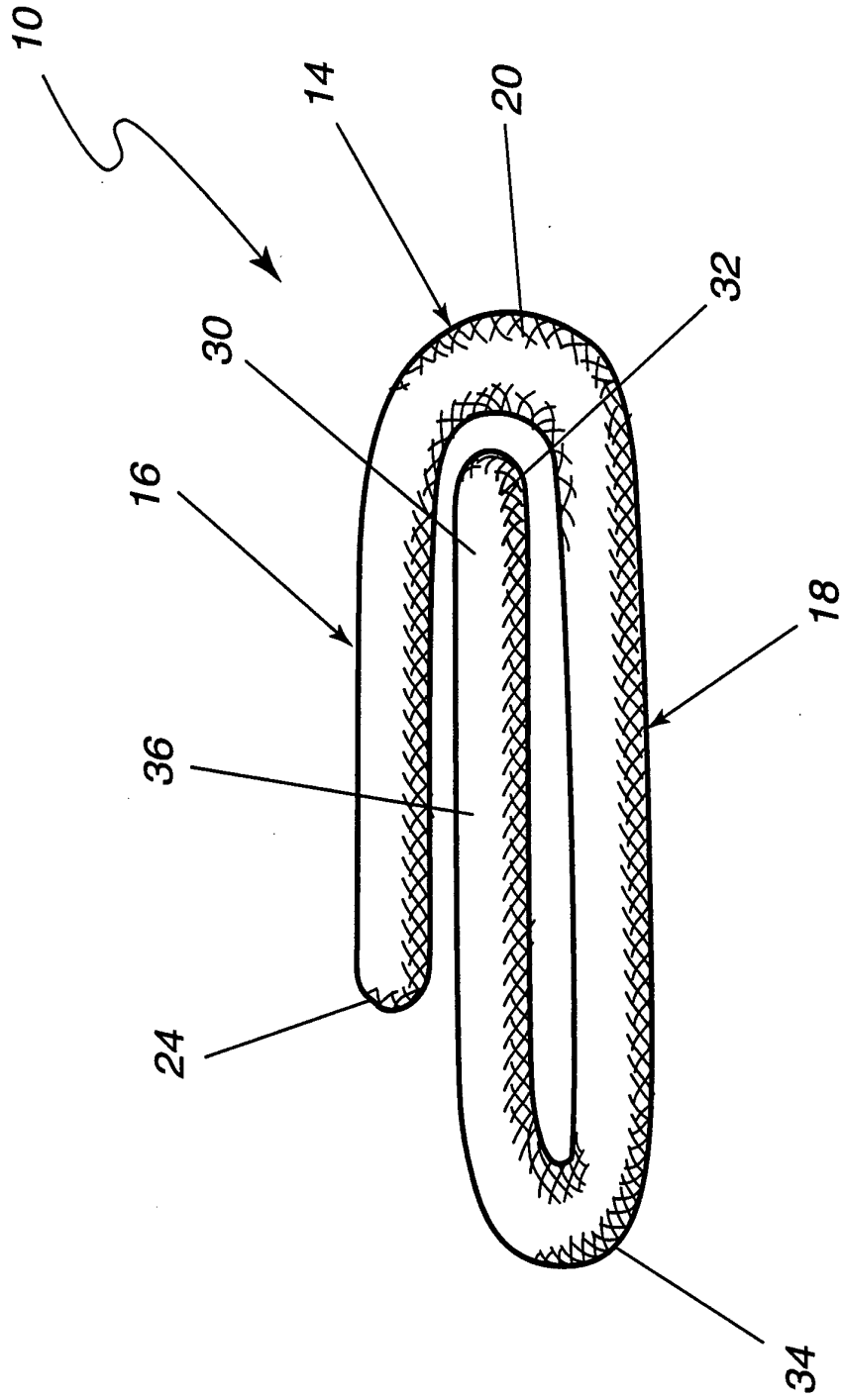

**FIG. 7**

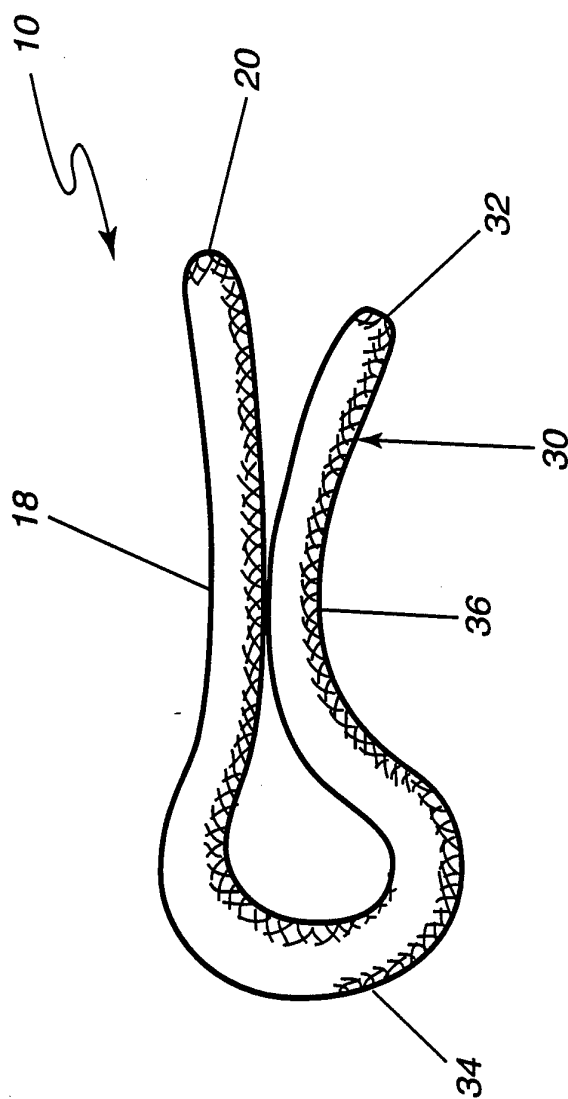

**FIG. 8**

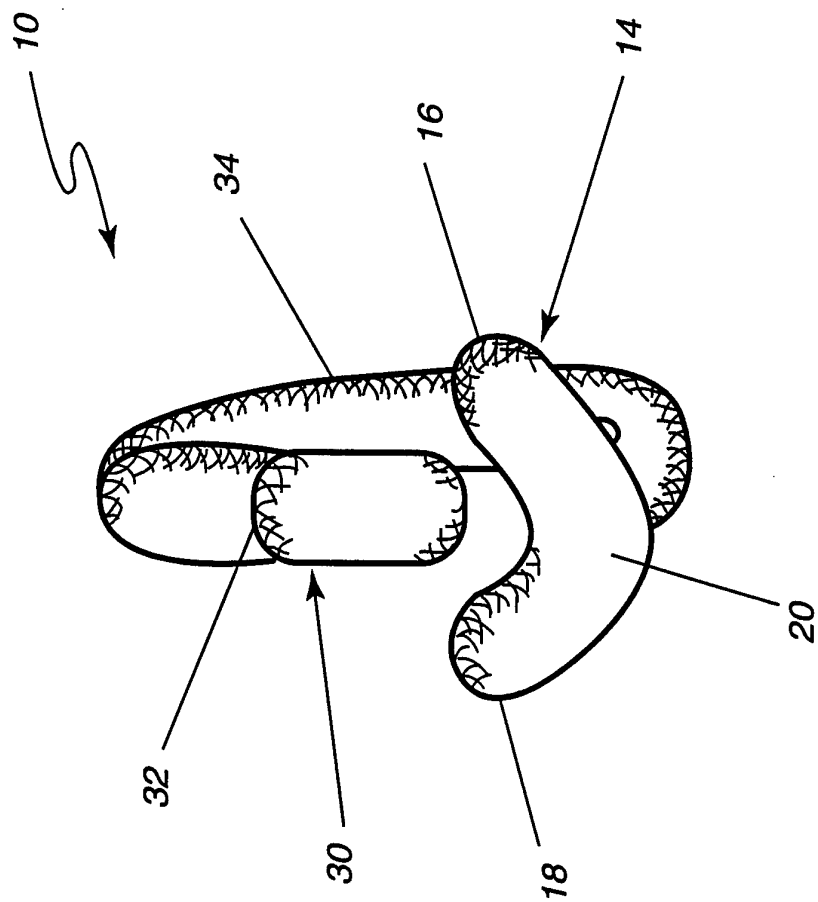

**FIG. 9**

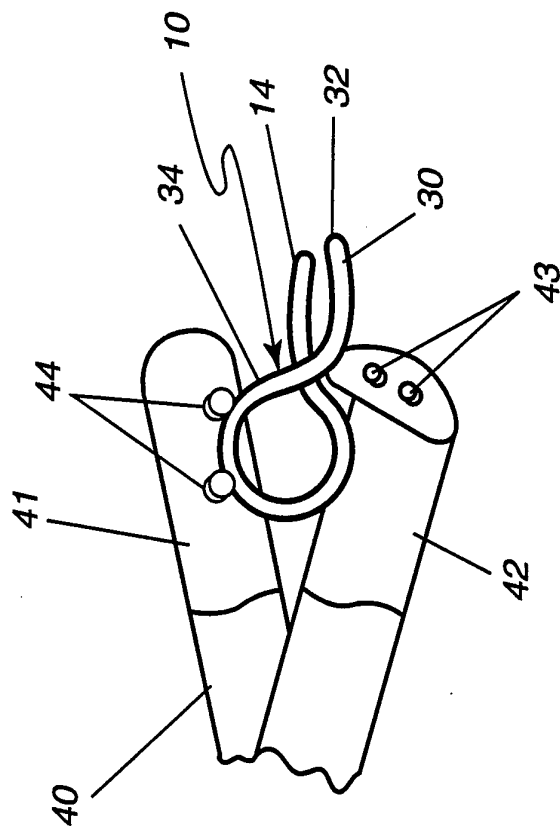

**FIG. 10**

INTERNATIONAL SEARCH REPORT

International application No.  
PCT/US94/09326

A. CLASSIFICATION OF SUBJECT MATTER

IPC(5) :A61B 17/12  
US CL :606/158

According to International Patent Classification (IPC) or to both national classification and IPC

B. FIELDS SEARCHED

Minimum documentation searched (classification system followed by classification symbols)

U.S. : 606/157, 158

Documentation searched other than minimum documentation to the extent that such documents are included in the fields searched  
NONE

Electronic data base consulted during the international search (name of data base and, where practicable, search terms used)  
NONE

C. DOCUMENTS CONSIDERED TO BE RELEVANT

Category*	Citation of document, with indication, where appropriate, of the relevant passages	Relevant to claim No.
X --- Y	US, A, 4,777,949, (PERLIN), 18 October 1988. See entire document.	1-16, 18-21 ----- 17
Y	US, A, 4,024,868, (WILLIAMS), 24 May 1977. See entire document.	17

Further documents are listed in the continuation of Box C.  See patent family annex.

* Special categories of cited documents:	"T" later document published after the international filing date or priority date and not in conflict with the application but cited to understand the principle or theory underlying the invention
"A" document defining the general state of the art which is not considered to be part of particular relevance	"X" document of particular relevance; the claimed invention cannot be considered novel or cannot be considered to involve an inventive step when the document is taken alone
"E" earlier document published on or after the international filing date	"Y" document of particular relevance; the claimed invention cannot be considered to involve an inventive step when the document is combined with one or more other such documents, such combination being obvious to a person skilled in the art
"L" document which may throw doubts on priority claim(s) or which is cited to establish the publication date of another citation or other special reason (as specified)	"&" document member of the same patent family
"O" document referring to an oral disclosure, use, exhibition or other means	
"P" document published prior to the international filing date but later than the priority date claimed	

Date of the actual completion of the international search

17 OCTOBER 1994

Date of mailing of the international search report

01 NOV 1994

Name and mailing address of the ISA/US  
Commissioner of Patents and Trademarks  
Box PCT  
Washington, D.C. 20231

Authorized officer

MICHAEL THALER

Facsimile No. (703) 305-3230

Telephone No. (703) 308-2981