



- (51) International Patent Classification:  
A61F 2/44 (2006.01) A61B 17/70 (2006.01)
- (21) International Application Number:  
PCT/US2014/019657
- (22) International Filing Date:  
28 February 2014 (28.02.2014)
- (25) Filing Language:  
English
- (26) Publication Language:  
English
- (30) Priority Data:  
13/789,507 7 March 2013 (07.03.2013) US
- (71) Applicant: INTERVENTIONAL SPINE, INC. [US/US];  
13700 Alton Parkway, Suite 160, Irvine, CA 92618 (US).
- (72) Inventors: FLOWER, Robert, J.; 27550 Ethan Allen  
Way, Sun City, CA 92585 (US). WARREN, Christopher,  
R.; 16 Openview, Aliso Viejo, CA 92656 (US). OLMOS,  
Fausto; 28358 Paseo El Siena, Laguna Niguel, CA 92677  
(US).
- (74) Agent: ALTMAN, Daniel, E.; Knobbe, Martens, Olson &  
Bear, LLP, 2040 Main Street, 14th Floor, Irvine, CA  
92614 (US).
- (81) Designated States (unless otherwise indicated, for every  
kind of national protection available): AE, AG, AL, AM,  
AO, AT, AU, AZ, BA, BB, BG, BH, BN, BR, BW, BY,

BZ, CA, CH, CL, CN, CO, CR, CU, CZ, DE, DK, DM, DO, DZ, EC, EE, EG, ES, FI, GB, GD, GE, GH, GM, GT, HN, HR, HU, ID, IL, IN, IR, IS, JP, KE, KG, KN, KP, KR, KZ, LA, LC, LK, LR, LS, LT, LU, LY, MA, MD, ME, MG, MK, MN, MW, MX, MY, MZ, NA, NG, NI, NO, NZ, OM, PA, PE, PG, PH, PL, PT, QA, RO, RS, RU, RW, SA, SC, SD, SE, SG, SK, SL, SM, ST, SV, SY, TH, TJ, TM, TN, TR, TT, TZ, UA, UG, US, UZ, VC, VN, ZA, ZM, ZW.

(84) Designated States (unless otherwise indicated, for every kind of regional protection available): ARIPO (BW, GH, GM, KE, LR, LS, MW, MZ, NA, RW, SD, SL, SZ, TZ, UG, ZM, ZW), Eurasian (AM, AZ, BY, KG, KZ, RU, TJ, TM), European (AL, AT, BE, BG, CH, CY, CZ, DE, DK, EE, ES, FI, FR, GB, GR, HR, HU, IE, IS, IT, LT, LU, LV, MC, MK, MT, NL, NO, PL, PT, RO, RS, SE, SI, SK, SM, TR), OAPI (BF, BJ, CF, CG, CI, CM, GA, GN, GQ, GW, KM, ML, MR, NE, SN, TD, TG).

**Declarations under Rule 4.17:**

- as to applicant's entitlement to apply for and be granted a patent (Rule 4.17(ii))
- as to the applicant's entitlement to claim the priority of the earlier application (Rule 4.17(iii))

**Published:**

- with international search report (Art. 21(3))

[Continued on next page]

(54) Title: INTERVERTEBRAL IMPLANT

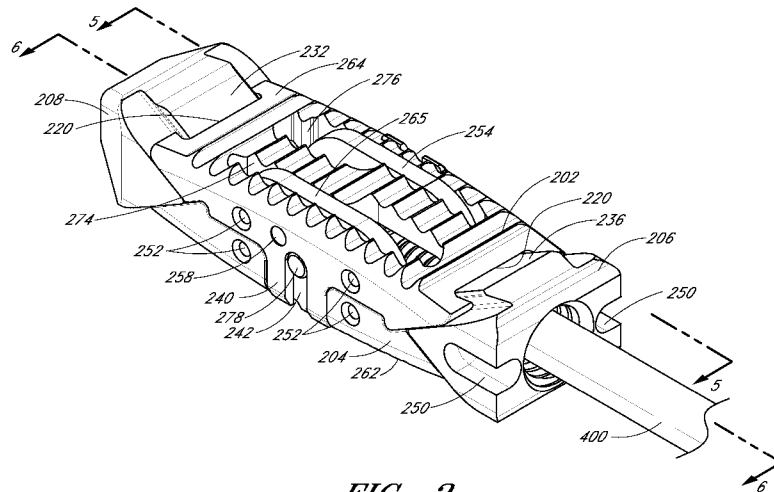


FIG. 3

(57) Abstract: An adjustable spinal fusion intervertebral implant including upper and lower body portions each having proximal and distal surfaces at proximal and distal ends thereof. The implant can include a proximal wedge member disposed at the proximal ends of the respective ones of the upper and lower body portions, and a distal wedge member disposed at the distal ends of the respective ones of the upper and lower body portions. First and second linkages can connect the upper and lower body portions. Rotation of an actuator shaft can cause the distal and proximal wedge members to be drawn together such that longitudinal movement of the distal wedge member against the distal surfaces and the longitudinal movement of the proximal wedge member against the proximal surfaces causes separation of the upper and lower body portions.



WO 2014/137839 A1

- *before the expiration of the time limit for amending the claims and to be republished in the event of receipt of amendments (Rule 48.2(h))*

## INTERVERTEBRAL IMPLANT

### BACKGROUND

#### Field

[0001] The present invention relates to medical devices and, more particularly, to an intervertebral implant.

#### Description of the Related Art

[0002] The human spine is a flexible weight bearing column formed from a plurality of bones called vertebrae. There are thirty three vertebrae, which can be grouped into one of five regions (cervical, thoracic, lumbar, sacral, and coccygeal). Moving down the spine, there are generally seven cervical vertebra, twelve thoracic vertebra, five lumbar vertebra, five sacral vertebra, and four coccygeal vertebra. The vertebra of the cervical, thoracic, and lumbar regions of the spine are typically separate throughout the life of an individual. In contrast, the vertebra of the sacral and coccygeal regions in an adult are fused to form two bones, the five sacral vertebra which form the sacrum and the four coccygeal vertebra which form the coccyx.

[0003] In general, each vertebra contains an anterior, solid segment or body and a posterior segment or arch. The arch is generally formed of two pedicles and two laminae, supporting seven processes--four articular, two transverse, and one spinous. There are exceptions to these general characteristics of a vertebra. For example, the first cervical vertebra (atlas vertebra) has neither a body nor spinous process. In addition, the second cervical vertebra (axis vertebra) has an odontoid process, which is a strong, prominent process, shaped like a tooth, rising perpendicularly from the upper surface of the body of the axis vertebra. Further details regarding the construction of the spine may be found in such common references as Gray's Anatomy, Crown Publishers, Inc., 1977, pp. 33-54, which is herein incorporated by reference.

[0004] The human vertebrae and associated connective elements are subjected to a variety of diseases and conditions which cause pain and disability. Among these diseases and conditions are spondylosis, spondylolisthesis, vertebral instability, spinal stenosis and degenerated, herniated, or degenerated and herniated intervertebral discs. Additionally, the

vertebrae and associated connective elements are subject to injuries, including fractures and torn ligaments and surgical manipulations, including laminectomies.

[0005] The pain and disability related to the diseases and conditions often result from the displacement of all or part of a vertebra from the remainder of the vertebral column. Over the past two decades, a variety of methods have been developed to restore the displaced vertebra to their normal position and to fix them within the vertebral column. Spinal fusion is one such method. In spinal fusion, one or more of the vertebra of the spine are united together (“fused”) so that motion no longer occurs between them. Thus, spinal fusion is the process by which the damaged disc is replaced and the spacing between the vertebrae is restored, thereby eliminating the instability and removing the pressure on neurological elements that cause pain.

[0006] Spinal fusion can be accomplished by providing an intervertebral implant between adjacent vertebrae to recreate the natural intervertebral spacing between adjacent vertebrae. Once the implant is inserted into the intervertebral space, osteogenic substances, such as autogenous bone graft or bone allograft, can be strategically implanted adjacent the implant to prompt bone in-growth in the intervertebral space. The bone ingrowth promotes long-term fixation of the adjacent vertebrae. Various posterior fixation devices (e.g., fixation rods, screws etc.) can also be utilize to provide additional stabilization during the fusion process.

[0007] Recently, intervertebral implants have been developed that allow the surgeon to adjust the height of the intervertebral implant. This provides an ability to intra-operatively tailor the intervertebral implant height to match the natural spacing between the vertebrae. This reduces the number of sizes that the hospital must keep on hand to match the variable anatomy of the patients.

[0008] In many of these adjustable intervertebral implants, the height of the intervertebral implant is adjusted by expanding an actuation mechanism through rotation of a member of the actuation mechanism. In some intervertebral implants, the actuation mechanism is a screw or threaded portion that is rotated in order to cause opposing plates of the implant to move apart. In other implants, the actuation mechanism is a helical body that is counter-rotated to cause the body to increase in diameter and expand thereby.

[0009] Furthermore, notwithstanding the variety of efforts in the prior art described above, these intervertebral implants and techniques are associated with another disadvantage. In particular, these techniques typically involve an open surgical procedure, which results higher cost, lengthy in-patient hospital stays and the pain associated with open procedures.

[0010] Therefore, there remains a need in the art for an improved intervertebral implant. Preferably, the implant is implantable through a minimally invasive procedure. Further, such devices are preferably easy to implant and deploy in such a narrow space and opening while providing adjustability and responsiveness to the clinician.

#### SUMMARY OF THE INVENTION

[0011] Certain aspects of this disclosure are directed toward an adjustable spinal fusion intervertebral implant. The implant can include upper and lower body portions each having proximal and distal surfaces at proximal and distal ends thereof. The proximal and distal surfaces of the upper and lower body portions can generally face each other. The implant can include a proximal wedge member disposed at the proximal ends of the respective ones of the upper and lower body portions, and a distal wedge member disposed at the distal ends of the respective ones of the upper and lower body portions. The implant can include first and second linkages each connected to the upper and lower body portions. The implant can include an actuator shaft received between the upper and lower body portions. The actuator shaft can extend intermediate the distal and proximal wedge members. Rotation of the actuator shaft can cause the distal and proximal wedge members to be drawn together such that longitudinal movement of the distal wedge member against the distal surfaces and the longitudinal movement of the proximal wedge member against the proximal surfaces causes separation of the upper and lower body portions. The implant features described in the specification can be included in any of the implant embodiments.

[0012] In some embodiments, The proximal surfaces of the respective ones of the upper and lower body portions each define a proximal slot therein, and distal surfaces of the respective ones of the upper and lower body portions each define a distal slot therein. In certain aspects, the slots of the proximal and distal surfaces of the upper and lower body portions are generally dove-tailed. In certain aspects, the proximal wedge member and the

distal wedge member can each include upper and lower guide members extending at least partially into the respective ones of the proximal and distal slots of the upper and lower body portions with at least a portion of the proximal wedge member and the distal wedge member contacting the proximal and distal surfaces of the upper and lower body portions. The guide members of the proximal and distal wedge members can be generally dovetailed.

[0013] In some embodiments, each of the upper and lower body portions can include a first side portion having an extending portion and a second side portion having a receiving portion. The first side portion of the upper body portion can be configured to mate with the second side portion of the lower body portion. The second side portion of the upper body portion can be configured to mate with the first side portion of the lower body portion. In certain aspects, the first and second side portions of the upper body portion can be configured to disengage from the first and second side portions of the lower body portion when the implant is in an expanded state.

[0014] In some embodiments, the proximal and distal surfaces of the upper and lower body portions can be sloped.

[0015] In some embodiments, the upper and lower body portions comprise generally arcuate respective upper and lower exterior engagement surfaces.

[0016] In some embodiments, the proximal wedge member can include an anti-rotational element. The anti-rotational engagement can be configured to engage an implant tool to prevent rotation of the implant when the actuator shaft is rotated relative to the implant. In certain aspects, the anti-rotational element can include a pair of apertures extending into the proximal wedge member.

[0017] In some embodiments, each of the first and second linkages can include at least one cam path. In certain aspects, a pin can extend from the at least one cam path to one of the upper and lower body portions.

[0018] In some embodiments, a length of the implant varies from about 45 mm to about 54 mm and/or a height of the implant varies from about 6.5 mm to about 12 mm during the separation of the upper and lower body portions. In certain aspects, the length of the implant varies from about 21 mm to about 31 mm during the separation of the upper and lower body portions.

[0019] In some embodiments, the upper and lower body portions can be coated with a bio-active coating, including, but not limited to, a hydroxyapatite coating, a titanium plasma spray, a resorbable blast media coating, or composite coatings.

[0020] Certain aspects of this disclosure are directed toward a method of manufacturing an adjustable spinal fusion intervertebral implant. The method can include extending an actuator shaft from a proximal wedge member to a distal wedge member. The method can include engaging the proximal and distal wedge members with each of the upper and lower body portions. The method can include connecting first and second linkages to each of the upper and lower body portions. The method of manufacturing steps described in the specification can be included in any of the embodiments discussed herein.

[0021] In some embodiments, extending the actuator shaft from the proximal wedge member to the distal wedge member can include inserting the actuator shaft through a central aperture of the proximal wedge member and through a central aperture of the distal wedge member.

[0022] In some embodiments, engaging the proximal and distal wedge members with each of the upper and lower body portions can include extending upper and lower guide members of the proximal and distal wedge members at least partially into respective ones of proximal and distal slots of the upper and lower body portions.

[0023] In some embodiments, the method can include engaging a first side portion of the upper body portion and a second side portion of the lower body portion. The first side portion can have an extending portion, and the second side portion can have a receiving portion. The receiving portion can be configured to receive the extending portion.

[0024] In some embodiments, engaging the first and second linkages with each of the upper and lower body portions can include extending a pin from a cam path of one of the first and second linkages to one of the upper and lower body portions.

[0025] In some embodiments, the method can include shot-peening the upper and lower body portions.

[0026] In some embodiments, the method can include coating the upper and lower body portions with a bio-active coating, including, but not limited to, a hydroxyapatite coating, a titanium plasma spray, a resorbable blast media coating, or composite coatings.

[0027] Certain aspects of this disclosure are directed toward a method of implanting an expandable intervertebral implant. The method can include positioning the implant between two vertebral bodies. The method can include rotating a screw mechanism of the implant to cause proximal and distal wedge members to converge toward each other and engage respective ones of proximal and distal surfaces of upper and lower body portions of the implant. The method can include separating the upper and lower body portions to cause the implant to expand. In certain aspects, separating the upper and lower body portions can cause first and second linkages to rotate from a first configuration to a second configuration. The method of use steps discussed in the specification can be included in any of the embodiments described herein.

[0028] In some embodiments, a height of the first and second linkages can be greater in the second configuration than in the first configuration.

[0029] In some embodiments, the method can include moving one or more pins along a respective cam path of one of the first and second linkages to cause the first and second linkages to rotate from the first configuration to the second configuration.

[0030] For purposes of summarizing the disclosure, certain aspects, advantages and features of the inventions have been described herein. It is to be understood that not necessarily any or all such advantages are achieved in accordance with any particular embodiment of the inventions disclosed herein. No aspects of this disclosure are essential or indispensable.

#### BRIEF DESCRIPTION OF THE DRAWINGS

[0031] FIG. 1 is a side view of an intervertebral implant in an unexpanded state while positioned intermediate adjacent vertebrae, according to an embodiment.

[0032] FIG. 2 is a side view of the intervertebral implant shown in FIG. 1 in an expanded state.

[0033] FIG. 3 is a perspective view of the intervertebral implant shown in FIG. 1 in an unexpanded state.

[0034] FIG. 4 is a perspective view of the intervertebral implant shown in FIG. 1 in an expanded state.



[0035] FIG. 5 is a side cross sectional view of the intervertebral implant shown in FIG. 3 in an unexpanded state, the cross sectional view is taken along line 5-5 of FIG. 3.

[0036] FIG. 6 is a side cross sectional view of the intervertebral implant shown in FIG. 3 in an unexpanded state, the cross sectional view is taken along line 6-6 of FIG. 3.

[0037] FIG. 7 is a side cross-sectional view of the intervertebral implant shown in FIG. 4 in an expanded state, the cross-sectional view is taken along line 7-7 of FIG. 4.

[0038] FIG. 8 is a side cross-sectional view of the intervertebral implant shown in FIG. 4 in an expanded state, the cross-sectional view is taken along line 8-8 of FIG. 4.

[0039] FIG. 9 is a bottom view of the intervertebral implant shown in FIG. 1 in an unexpanded state.

[0040] FIG. 10 is a side view of the intervertebral implant shown in FIG. 1 in an expanded state.

[0041] FIG. 11 is a front cross-sectional view of the intervertebral implant shown in FIG. 10 taken along lines 11-11.

[0042] FIG. 12 is a top perspective view of an upper body portion of the intervertebral implant shown in FIG. 1.

[0043] FIG. 13 is a bottom perspective view of the upper body portion of the intervertebral implant shown in FIG. 1.

[0044] FIG. 14 is a perspective view of an actuator shaft of the intervertebral implant shown in FIG. 1.

[0045] FIG. 15 is a front perspective view of a proximal wedge member of the intervertebral implant shown in FIG. 1.

[0046] FIG. 16 is a rear perspective view of the proximal wedge member of the intervertebral implant shown in FIG. 1.

[0047] FIG. 17 is a front perspective view of a distal wedge member of the intervertebral implant shown in FIG. 1.

[0048] FIG. 18 is a rear perspective view of the distal wedge member of the intervertebral implant shown in FIG. 1.

[0049] FIG. 19A illustrates a perspective view of a linkage of the intervertebral implant shown in FIG. 1.

[0050] FIG. 19B illustrates a side view of the linkage illustrated in FIG. 19A.

[0051] FIG. 19C illustrates a top view of the linkage illustrated in FIG. 19A.

[0052] FIG. 20 is a perspective view of a long pin of the intervertebral implant shown in FIG. 1.

[0053] FIG. 21 is a perspective view of a short pin of the intervertebral implant shown in FIG. 1.

#### DETAILED DESCRIPTION

[0054] In accordance with certain embodiments disclosed herein, an improved intervertebral implant is provided that allows the clinician to insert the intervertebral implant through a minimally invasive procedure. For example, one or more intervertebral implants can be inserted percutaneously to reduce trauma to the patient and thereby enhance recovery and improve overall results of the surgery.

[0055] An intervertebral implant can include a plurality of body sections that are selectively separable and expandable upon contraction of a centrally disposed actuator. The actuator can be utilized to contract against faces of the body sections to cause the expansion thereof. The implant can also be configured such that the actuator provides for both the expansion and contraction of the body sections. The actuator can comprise an interaction between the body sections and another element, an action performed by another element, or a combination of interactions between various elements of the implant and its body sections. Further, the implant can be configured to allow either rough or fine incremental adjustments in the expansion of the implant.

[0056] The embodiments disclosed herein are discussed in the context of an intervertebral implant and spinal fusion because of the applicability and usefulness in such a field. As such, various embodiments can be used to properly space adjacent vertebrae in situations where a disc has ruptured or otherwise been damaged. As also disclosed herein, embodiments can also be used as vertebral body replacements. Thus, "adjacent" vertebrae can include those originally separated only by a disc or those that are separated by intermediate vertebra and discs. Such embodiments can therefore tend to recreate proper disc height and spinal curvature as required in order to restore normal anatomical locations and distances. However, it is contemplated that the teachings and embodiments disclosed herein can be beneficially implemented in a variety of other operational settings, for spinal surgery and otherwise.

[0057] For example, the implant disclosed herein can also be used as a vertebral body replacement. In such a use, the implant could be used as a replacement for a lumbar vertebra, such as one of the L1-L5 vertebrae. Thus, the implant could be appropriately sized and configured to be used intermediate adjacent vertebrae, or to entirely replace a damaged vertebra.

[0058] It is contemplated that the implant can be used as an interbody or intervertebral device or can be used to replace a vertebral body entirely. The implant can also be used in vertebral body compression fractures. Further, the implant can be used as a tool to expand an intervertebral space or bone in order to fill the space or bone with a cement; in such cases, the implant can be removed or left in once the cement is placed. Furthermore, the implant can also be used as a tool to pre-dilate the disc space. In some embodiments, the implant can be removed once the disc space is dilated, and a different implant (expandable or non-expandable) can then be implanted in the dilated disc space. The implant can also be introduced into the disc space anteriorly in an anterior lumbar interbody fusion (ALIF) procedure, posterior in an posterior lumbar interbody fusion (PLIF) or posterior lateral interbody fusion, from extreme lateral position in an extreme lateral interbody fusion procedure (XLIF) or direct lateral interbody fusion (DLIF), from a far lateral position in a transforaminal lumbar interbody fusion (TLIF), to name a few. In other arrangements, the implant can be inserted through the Kambin triangle or be inserted through the Kambin triangle after the Kambin triangle has been enlarged via removing bone (e.g., techniques such as PerX360° System™ sold by Intervention Spine®). Although the implant is primarily described herein as being used to expand in a vertical direction, it can also be implanted to expand in a horizontal direction in order to increase stability and/or increase surface area between adjacent vertebral bodies.

[0059] Therefore, it is contemplated that a number of advantages can be realized utilizing various embodiments disclosed herein. For example, as will be apparent from the disclosure, no external distraction of the spine is necessary. Further, no distraction device is required in order to install various embodiments disclosed herein. In this regard, embodiments of the implant can enable sufficient distraction of adjacent vertebra in order to properly restore disc height or to use the implant as a vertebral body replacement. Thus,

normal anatomical locations, positions, and distances can be restored and preserved utilizing many of the embodiments disclosed herein.

[0060] Referring to FIG. 1, there is illustrated a side view of an embodiment of a intervertebral implant 200 in an unexpanded state while positioned generally between adjacent vertebrae of the lumbar portion of the spine 212. FIG. 2 illustrates the intervertebral implant 200 in an expanded state, thereby supporting the vertebrae in a desired orientation and spacing in preparation for spinal fusion. As is known in the art, spinal fusion is the process by which the adjacent vertebrae of the spine are united together (“fused”) so that motion no longer occurs between the vertebrae. Thus, the intervertebral implant 200 can be used to provide the proper spacing two vertebrae to each other pending the healing of a fusion. *See also* U.S. Patent No. 7,824,429, filed July 18, 2003, the entirety of the disclosure of which is hereby incorporated by reference.

[0061] In certain embodiment, the implant can be installed in an operation that generally entails the following procedures. The damaged disc or vertebra can be decompressed, such as by distracting. The subject portion (or entire) disc or vertebra can then be removed. The adjacent vertebrae can be prepared by scraping the exposed adjacent portion or plates thereof (typically to facilitate bleeding and circulation in the area). Typically, most of the nucleus of the disc is removed and the annulus of the disc is thinned out. Although individual circumstances may vary, it may be unusual to remove all of the annulus or to perform a complete discectomy. The implant can then be installed. In some embodiments, distraction of the disc may not be a separate step from placement of the implant; thus, distraction can be accomplished and can occur during placement of the implant. Finally, after implantation of the implant, osteogenic substances, such as autogenous bone graft, bone allograft, autograft foam, or bone morphogenic protein (BMP) can be strategically implanted adjacent the implant to prompt bone in-growth in the intervertebral space. In this regard, as the implant is expanded, the spaces within the implant can be backfilled; otherwise, the implant can be pre-packed with biologics.

[0062] The intervertebral implant is often used in combination with posterior and/or anterior fixation devices (e.g., rods, plates, screws, etc. that span two or more vertebrae) to limit movement during the fusion process. U.S. Patent No. 7,824,429 discloses a particularly advantageous posterior fixation device and method which secures two adjacent

vertebra to each other in a trans-laminar, trans-facet or facet-pedicle (e.g., the Boucher technique) application using fixation screws.

[0063] It should also be appreciated that in FIGS. 1 and 2 only one intervertebral implant 200 is shown positioned between the vertebrae 212. However, two, three, or more implants 200 can be inserted into the space between the vertebrae 212. Further, other devices, such as bone screws, can be used on the vertebrae as desired. For example, in a spinal fusion procedure, it is contemplated that one or more implants 200 can be used in conjunction with one or more bone screws and/or dynamic stabilization devices, such as those disclosed in the above-mentioned U.S. Patent No. 7,824,429, filed July 18, 2003.

[0064] In certain embodiments, the implant 200 can be used in combination with a dynamic stabilization devices such as those disclosed in U.S. Patent No. 7,648,523, filed February 11, 2005; U.S. Patent No. 6,951,561, filed on May 6, 2004; U.S. Patent No. 7,998,176, filed on June 6, 2008; and U.S. Patent No. 7,824,429, filed July 18, 2003; the entireties of the disclosures of which are hereby incorporated by reference. In this manner, the implant 200 can be used to maintain height between vertebral bodies while the dynamic stabilization device provides limits in one or more degrees of movement.

[0065] FIG. 3 is a perspective view of an intervertebral implant 200 in an unexpanded state, and FIGS. 5 and 6 illustrate cross-sections of the intervertebral implant 200 in the unexpanded state. The implant 200 can comprise upper and lower body portions 202, 204, proximal and distal wedge members 206, 208, first and second linkages 254, 265, and an actuator shaft 210. In the unexpanded state, the upper and lower body portions 202, 204 can be generally abutting with a height of the implant 200 being minimized. However, the implant 200 can be expanded, as shown in FIG. 4, to increase the height of the implant 200 when implanted into the intervertebral space of the spine. FIGS. 7 and 8 illustrate cross-sections of the intervertebral implant 200 in the expanded state.

[0066] It is contemplated that the actuator shaft 210 can be rotated to cause the proximal and distal wedge members to move toward each other, thus causing the upper and lower body portions 202, 204 to be separated. In some embodiments, the implant 200 can include one or more linkages configured to connect the upper and lower body portions 202, 204 when the implant 200 is in an expanded state. For example, as shown in Figures 3 and 4, the implant 200 can include first and second linkages 254, 265. The linkages 254, 265 can

be configured to move between a first configuration (shown in FIG. 5) and a second configuration (shown in FIG. 7).

[0067] Each of the intervertebral implant components will be described in further detail below in reference to FIGS. 9-21.

[0068] In some embodiments, the height of the implant 200 can be or vary within a range from at least about 6 mm to less than or equal to about 15 mm, and more preferably, from about 6.5 mm to about 12 mm. The width of the implant can be at least about 7 mm and/or less than or equal to about 18 mm, and preferably approximately 9 mm or 18 mm. Thus, the implant 200 can have a preferred aspect ratio of between approximately 6:18 and 15:7, and preferably approximately between 6.5:9 and 12:9, or between 6.5:18 and 12:18.

[0069] The length of the implant 200 can be or vary within a range from at least 18 mm to less than or equal to about 54 mm. In certain aspects, the length of the implant 200 can be or vary within a range from least about 18 mm to less than or equal to about 35 mm, and preferably from about 25 mm to about 31 mm. In certain aspects, the length of the implant 200 can be or vary within a range from least about 45 mm to less than or equal to about 54 mm. In some embodiments, the implant can have a greater length in the unexpanded state than in the expanded state. It is contemplated that various modifications to the dimension disclosed herein can be made by one of skill and the mentioned dimensions shall not be construed as limiting.

[0070] The intervertebral implant components can be manufactured in accordance with any of a variety of techniques which are well known in the art, using any of a variety of medical-grade construction materials. For example, the upper and lower body portions 202, 204, the actuator shaft 210, and other components can be injection-molded from a variety of medical-grade polymers including high or other density polyethylene, PEEK<sup>TM</sup> polymers, nylon and polypropylene.

[0071] The intervertebral implant 200 components can be molded, formed or machined from biocompatible metals such as Nitinol, stainless steel, titanium, and others known in the art. Non-metal materials such as plastics, PEEK<sup>TM</sup> polymers, and rubbers can also be used. Further, the implant components can be made of combinations of PEEK<sup>TM</sup> polymers and metals. In some embodiments, the intervertebral implant components can be

injection-molded from a bioabsorbable material, to eliminate the need for a post-healing removal step.

[0072] The intervertebral implant components may be coated with or contain one or more bioactive substances, such as antibiotics, chemotherapeutic substances, angiogenic growth factors, substances for accelerating the healing of the wound, growth hormones, anti-thrombogenic agents, bone growth accelerators or agents, and the like. Such bioactive implants may be desirable because they contribute to the healing of the injury in addition to providing mechanical support. For example, in some embodiments, the upper and lower body portions 202, 204 can be coated with a bio-active coating, including, but not limited, to a hydroxyapatite coating, a titanium plasma spray, a resorbable blast media coating, or composite coatings. The upper and lower body portions 202, 204 can be coated after the implant is fully assembled, such that other components exposed along the upper and lower surfaces of the implant can also be coated with hydroxyapatite.

[0073] In some embodiments, the intervertebral implant components can be surface treated to increase the strength of the components. For example, the intervertebral implant components can be sand blasted, shot peened, laser peened, or otherwise treated to increase strength.

[0074] In addition, the intervertebral implant components may be provided with any of a variety of structural modifications to accomplish various objectives, such as osteoincorporation, or more rapid or uniform absorption into the body. For example, osteoincorporation may be enhanced by providing a micropitted or otherwise textured surface on the intervertebral implant components. Alternatively, capillary pathways may be provided throughout the intervertebral implant, such as by manufacturing the intervertebral implant components from an open cell foam material, which produces tortuous pathways through the device. This construction increases the surface area of the device which is exposed to body fluids, thereby generally increasing the absorption rate. Capillary pathways may alternatively be provided by laser drilling or other technique, which will be understood by those of skill in the art in view of the disclosure herein. Additionally, apertures can be provided in the implant to facilitate packing of biologics into the implant, backfilling, and/or osseointegration of the implant. In general, the extent to which the intervertebral implant can be permeated by capillary pathways or open cell foam passageways may be determined by

balancing the desired structural integrity of the device with the desired reabsorption time, taking into account the particular strength and absorption characteristics of the desired polymer.

[0075] The implant 200 can be at least partially radiolucent, which radiolucency can allow a doctor to perceive the degree of bone growth around and through the implant. The individual components of the implant 200 can be fabricated of such materials based on needed structural, biological and optical properties.

[0076] The intervertebral implant may be sterilized by any of the well-known sterilization techniques, depending on the type of material. Suitable sterilization techniques include heat sterilization, ultrasonic sterilization, radiation sterilization, such as cobalt irradiation or electron beams, ethylene oxide sterilization, and the like.

[0077] FIG. 9 is a bottom view of the implant 200 shown in FIG. 3. As shown therein, each of the upper and lower body portions 202, 204 can also include one or more openings 274, 276 for receiving the first and second linkages 254, 265 and/or receiving graft material or other bioactive substances. The openings 274, 276 can be disposed on either side of a central receptacle 298 (FIG. 13).

[0078] In some embodiments, the two openings 274, 276 can be similarly shaped. For example, as shown in FIG. 9, each opening 274, 276 can include a first elongate portion having a width and a second portion having a width greater than the first elongate portion width. As shown in FIG. 9, at least a part of the actuator shaft 210 is visible through the second portion of each opening 274, 276. The second opening 276 can be disposed at a 180 degree angle from the first opening 274 and/or horizontally displaced from the first opening 274.

[0079] In certain variants, the openings 274, 276 can be single elongate portions through which the first and second linkages 254, 265 extend. Although not shown in the FIGS., the upper and lower body portions 202, 204 can include additional openings for receiving graft material or other bioactive substances. Each of the openings can be shaped similarly or differently. The additional openings can be vertically and/or horizontally displaced from each other along the upper and body portions 202, 204. The additional opens can be aligned with a longitudinal axis of the implant 200 or positioned off-center. One or more of the openings can be generally rounded, including, but not limited to, a generally



elliptical shape, or include a light-bulb shape. The width of one or more of the openings can vary across a length of the opening.

[0080] In some embodiments, the implant 200 can comprise one or more protrusions 260 on a bottom surface 262 of the lower body portion 204. As shown in FIG. 12, the upper body portion 204 can also define a top surface having one or more protrusions 260 thereon. The protrusions 260 can allow the implant 200 to engage the adjacent vertebrae when the implant 200 is expanded to ensure that the implant 200 maintains a desired position in the intervertebral space.

[0081] The protrusions 260 can be configured in various patterns. As shown, the protrusions 260 can be formed from grooves extending widthwise along the bottom surface 262 of the implant 200 (also shown extending from a top surface 264 of the upper body portion 202 of the implant 200). The protrusions 260 can become increasingly narrow and pointed toward their apex. However, it is contemplated that the protrusions 260 can be one or more raised points, cross-wise ridges, or the like.

[0082] In FIG. 9, the implant 200 is illustrated in the unexpanded state with each of the respective slots 222 of the lower body portion 204 and lower guide members 270, 272 of the respective ones of the proximal and distal wedge members 206, 208. In some embodiments, as shown in FIGS. 12-13, the slots and guide members can be configured to incorporate a generally dovetail shape. Thus, once a given guide member is slid into engagement with a slot, the guide member can only slide longitudinally within the slot and not vertically from the slot. This arrangement can ensure that the proximal and distal wedge members 206, 208 are securely engaged with the upper and lower body portions 202, 204.

[0083] In FIG. 10, a side view of the embodiment of the implant 200 in the expanded state illustrates the angular relationship of the proximal and distal wedge members 206, 208 and the upper and lower body portions 202, 204. As mentioned above, the dovetail shape of the slots and guide members ensures that for each given slot and guide member, a given wedge member is generally interlocked with the give slot to only provide one degree of freedom of movement of the guide member, and thus the wedge member, in the longitudinal direction of the given slot.

[0084] Accordingly, in such an embodiment, the wedge members 206, 208 may not be separable from the implant when the implant 200 is in the unexpanded state (as shown

in FIG. 3) due to the geometric constraints of the angular orientation of the slots and guide members with the actuator shaft inhibiting longitudinal relative movement of the wedge members 206, 208 relative to the upper and lower body portions 202, 204. Such a configuration ensures that the implant 200 is stable and structurally sound when in the unexpanded state or during expansion thereof, thus facilitating insertion and deployment of the implant 200.

[0085] Such an embodiment of the implant 200 can therefore be assembled by placing or engaging the wedge members 206, 208 with the actuator shaft 210, moving the wedge members 206, 208 axially together, and inserting the upper guide members 230, 232 into the slots 220 of the upper body portion 202 and the lower guide members 270, 272 into the slots 222 of the lower body portion 204. The wedge members 206, 208 can then be moved apart, which movement can cause the guide members and slots to engage and bring the upper and lower body portions toward each other. The implant 200 can then be prepared for insertion and deployment by reducing the implant 200 to the unexpanded state.

[0086] Referring again to FIG. 10, the implant 200 can define generally convex top and bottom surfaces 264, 262. This shape can be configured to generally match the concavity of adjacent vertebral bodies.

[0087] FIGS. 12-13 illustrate perspective views of the upper body portion 202 of the implant 200, according to an embodiment. These FIGS. provide additional clarity as to the configuration of the slots 220 and illustrate a first and second side portions 240, 242 of the upper body portion 202. The upper and lower body portions 202, 204 can also define a central receptacle 298 wherein the actuator shaft can be received, and two openings 274, 276 for receiving the first and second linkages 254, 265. Although the FIGS. illustrate the actuator shaft 210 disposed along a central receptacle 298 of the upper and lower body portions 202, 204, in certain variants, the actuator shaft 210 can be disposed off-center. This may be useful to provide a continuous graft channel along a central portion of the implant, from the top surface of the implant to the bottom surface of the implant.

[0088] It is contemplated that some embodiments of the implant 200 can be configured such that the upper and lower body portions 202, 204 each include side portions (shown as first side portion 240 and second side portion 242 of the upper body portion 202) to facilitate the alignment, interconnection, and stability of the components of the implant

200. The first and second side portions 240, 242 can be configured to have complementary structures that enable the upper and lower body portions 202, 204 to move in a vertical direction and maintain alignment in a horizontal direction. For example, as shown in FIGS. 12-13, the first side portion 240 can include an extending portion and the second side portion 242 can include a receiving portion for receiving the extending portion of the first side portion 240. As shown in FIG. 10, the first and second side portions 240, 242 of the upper body portion 202 can be configured to disengage from the first and second side portions 240, 242 of the lower body portion 202 when the implant 200 is in the expanded state.

[0089] FIG. 9 illustrates a bottom view of the profile of an embodiment of the first side portion 240 and the second side portion 242. As shown in FIG. 9, having a pair of each of first and second side portions 240, 242 can ensure that the upper and lower body portions 202, 204 do not translate relative to each other, thus further ensuring the stability of the implant 200.

[0090] In some embodiments, the implant 200 can be configured to include one or more apertures 252 to facilitate osseointegration of the implant 200 within the intervertebral space. As mentioned above, the implant 200 may contain one or more bioactive substances, such as antibiotics, chemotherapeutic substances, angiogenic growth factors, substances for accelerating the healing of the wound, growth hormones, anti-thrombogenic agents, bone growth accelerators or agents, and the like. Indeed, various biologics can be used with the implant 200 and can be inserted into the disc space or inserted along with the implant 200. The apertures 252 can facilitate circulation and bone growth throughout the intervertebral space and through the implant 200. In such implementations, the apertures 252 can thereby allow bone growth through the implant 200 and integration of the implant 200 with the surrounding materials.

[0091] As shown in FIG. 14, the actuator shaft 210 can have at least one thread 294 disposed along at least a portion thereof, if not along the entire length thereof. The actuator shaft 210 can be threadably and/or freely attached to one or both of the proximal and distal wedge members 206, 208. The actuator shaft 210 can also be configured such that a proximal portion of the actuator shaft 210 can be removed after the implant 200 has been expanded in order to eliminate any proximal protrusion of the actuator shaft 210. Although, the present embodiment is illustrated using this mode of expansion, it is contemplated that

other modes of expansion (e.g., one way-ratchet type mechanism) can be combined with or interchanged herewith.

[0092] The threads can be configured to be left hand threads at a distal end of the actuator shaft 210 and right hand threads at a proximal other end of the actuator shaft 210 for engaging the respective ones of the distal and proximal wedge members 208, 206. Accordingly, upon rotation of the actuator shaft 210, the wedge members 206, 208 can be caused to move toward or away from each other to facilitate expansion or contraction of the implant 200.

[0093] In some embodiments, the actuator shaft 210 can facilitate expansion of the implant 200 through rotation, longitudinal contract of the pin, or other mechanisms. The actuator shaft 210 can include threads that threadably engage at least one of the proximal and distal wedge members 206, 208. The actuator shaft 210 can also facilitate expansion through longitudinal contraction of the actuator shaft as proximal and distal collars disposed on inner and outer sleeves move closer to each other to in turn move the proximal and distal wedge members closer together. It is contemplated that in certain variants, at least a portion of the actuator shaft can be axially fixed relative to one of the proximal and distal wedge members 206, 208 with the actuator shaft being operative to move the other one of the proximal and distal wedge members 206, 208 via rotational movement or longitudinal contraction of the pin.

[0094] In some embodiments, wherein the actuator shaft 210 is threaded, it is contemplated that the actuator shaft 210 can be configured to bring the proximal and distal wedge members closer together at different rates. In such embodiments, the implant 200 could be expanded to a V-configuration or wedged shape. For example, the actuator shaft 210 can comprise a variable pitch thread that causes longitudinal advancement of the distal and proximal wedge members at different rates. The advancement of one of the wedge members at a faster rate than the other could cause one end of the implant to expand more rapidly and therefore have a different height than the other end. Such a configuration can be advantageous depending on the intervertebral geometry and circumstantial needs.

[0095] The actuator shaft 210 can be utilized to provide a stabilizing axial force to the proximal and distal wedge members 206, 208 in order to maintain the expansion of the implant 200. However, it is also contemplated that other features can be incorporated into

such an embodiment to facilitate the maintenance of the expansion. In this regard, although the axial force provided by the actuator shaft 210 can tend to maintain the position and stability of the proximal and distal wedge members 206, 208, additional features can be employed to ensure the strength and stability of the implant 200 when in its expanded state. For example, the proximal and distal wedge members 206, 208 can include ribbed engagement surfaces (not shown). The use of the ribbed engagement surfaces can permit one-way, ratchet type longitudinal movement of proximal and distal wedge members 206, 208 relative to the upper and lower body portions 202, 204 in order to maintain the upper and lower body portions at a given separation distance. Various other features that can be used to facilitate the expansion of two body portions of an intervertebral implant are disclosed in U.S. Patent No. 8,105,382, filed December 7, 2007, the entirety of which is hereby incorporated by reference.

[0096] The actuator shaft 210 can be cannulated and/or include one or more apertures. The one or more apertures and/or cannula can provide access to an internal portion of the implant, so bone graft or other bioactive materials described herein can be directly injected into the implant to promote fusion.

[0097] In accordance with an embodiment, the actuator shaft 210 can also comprise a tool engagement section 296. The tool engagement section 296 can be configured to be engaged by a tool 400. The tool engagement section 296 can be shaped as a polygon, such as a hex shape to facilitate the transfer of torque to the actuator shaft 210 from the tool 400. For example, the tool 400 can include a distal engagement member 430 being configured to engage a proximal end of the actuator shaft 210 of the implant 200 for rotating the actuator shaft 210 to thereby expand the implant from an unexpanded state to an expanded state.

[0098] The proximal end of the actuator shaft can also include a number of tool engagement features configured to engage with a number of corresponding engagement features at a distal end of the tool 400 (shown in FIG. 4). These tool engagement features can be configured to increase torque strength and facilitate rotation of the actuator shaft. As shown in Figure 14, the tool engagement features can take the form of one or more grooves or indentations. The number of tool engagement features can equal the number of faces on the tool engagement section. For example, the actuator shaft 210 can include six tool

engagement features. The tool engagement features can be disposed at a proximal end of the actuator shaft 210, between the threaded portion 294 and the tool engagement section 296. In certain aspects, the tool engagement features can surround a base of the tool engagement section 296. Figure 4 illustrates the corresponding engagement features of the tool 400. The corresponding features can take the form of protrusions, nubs, fingers, or otherwise, at the distal end of the tool 400.

**[0099]** FIG. 15-16 illustrate perspective views of the proximal wedge member 206 of the implant 200. The proximal wedge member 206 can include one or more anti-torque structures 250. Further, the guide members 230, 270 are also illustrated. The proximal wedge member 206 can comprise a central aperture 300 wherethrough an actuator shaft can be received. When actuator shaft 210 is used in an embodiment, the central aperture 300 can be threaded to correspond to the threads 294 of the actuator shaft 210. In other embodiments, the actuator shaft can engage other portions of the wedge member 206 for causing expansion or contraction thereof.

**[0100]** In some embodiments, the implant 200 can be configured such that the proximal and distal wedge members 206, 208 are interlinked with the upper and lower body portions 202, 204 to improve the stability and alignment of the implant 200. For example, the upper and lower body portions 202, 204 can be configured to include slots (slot 220 is shown in FIG. 3, and slots 220, 222 are shown in FIG. 4). The proximal and distal wedge members 206, 208 can be configured to include at least one guide member (an upper guide member 230 of the proximal wedge member 206 is shown in FIGS. 15-16 and an upper guide member 232 of the distal wedge member 208 is shown in FIGS. 17-18) that at least partially extends into a respective slot 220, 222 of the upper and lower body portions 202, 204. The arrangement of the slots and the guide members can enhance the structural stability and alignment of the implant 200.

**[0101]** In some embodiments, the implant 200 can be configured to include anti-torque structures 250. The anti-torque structures 250 can interact with at least a portion of a deployment tool during deployment of the implant to ensure that the implant maintains its desired orientation. For example, when the implant 200 is being deployed and a rotational force is exerted on the actuator shaft 210, the anti-torque structures 250 can be engaged by a non-rotating structure of the deployment tool to maintain the rotational orientation of the

implant 200 while the actuator shaft 210 is rotated. The anti-torque structures 250 can comprise one or more inwardly extending holes or indentations on the proximal wedge member 206, which are shown as a pair of holes in FIGS. 3-4. However, the anti-torque structures 250 can also comprise one or more outwardly extending structures.

**[0102]** The tool 400 can also include an anti-torque component to engage one or more anti-torque structures 250 of the implant 200. The anti-torque component can include one or more protrusions that engage the anti-torque structures 250 to prevent movement of the implant 200 when a rotational force is applied to the actuator shaft 210 via the tool 400. Other deployment methods can also be used, such as those disclosed in U.S. Patent No. 8, 105, 382.

**[0103]** FIG. 17-18 illustrate perspective views of the distal wedge member 208 of the implant 200. As similarly discussed above with respect to the proximal wedge member 206, the guide members 232, 272 and a central aperture 302 of the proximal wedge member 206 are illustrated. The central aperture 302 can be configured to receive an actuator shaft therethrough. When actuator shaft 210 is used in an embodiment, the central aperture 302 can be threaded to correspond to the threads 294 of the actuator shaft 210. In other embodiments, the actuator shaft can engage other portions of the wedge member 208 for causing expansion or contraction thereof.

**[0104]** As shown in FIGS. 19A-19C, each linkage 254, 265 can have a width W and a length L. The length L can be substantially longer than the width W. In some embodiments, the length L can be at least two times the width W, at least three times the W, or otherwise. Each linkage 254, 265 can include one or more cam paths 282, 284 through which a long pin 258 (FIG. 20) or a short pin 263 (FIG. 21) can move. Each linkage can also include shaft portions 278, 286. The axis extending through the shaft portions 278, 286 can be substantially transverse to the longitudinal axis of the linkages 254, 265. Shaft portion 278 can be longer than shaft portion 286.

**[0105]** The linkages can be positioned such that the longer shaft portion 278 can engage the side portions 240, 242 of the upper and lower body portions 202, 204. For example, each of the side portions 240, 242 can include a receiving portion 293, 295 for receiving the longer shaft portion 278 when the implant 202 is in the unexpanded state. Each of the upper and lower body portions 202, 204 can also include internal receiving portions

297, 299 for receiving the shorter shaft portions 286 when the implant 200 is in the unexpanded state. The receiving portions can be slots, grooves, indentations, or other features capable of receiving the shaft portions 278, 286.

**[0106]** The linkages 254, 265 can facilitate the alignment, interconnection, and stability of the upper and lower body portions 202, 204. As shown in FIG. 4, the long and short pins 258, 263 can connect the linkages 254, 265 to the upper and lower body portions 202, 204. The upper and lower body portions 202, 204 can each include apertures 290, 292 for receiving the pins 258, 263 (shown in FIGS. 12-13). For example, the long pin 258 can extend from the cam path 284 to the side portion aperture 290 disposed on the first side portion 240, and the short pin 263 can extend from the cam path 282 to the to the side portion aperture 292 disposed on the second side portion 242. FIG. 11 illustrates how the upper and lower body portions 202, 204 can connect to linkages 254, 265 via the pins 263. FIG. 11 illustrates a cross-section of FIG. 10 taken along line 11-11.

**[0107]** In addition, the linkages 254, 265 can act as motion limiting structures that limit the separation between the upper and lower body portions 202, 204. As the upper and lower side portions 202, 204 move apart, the pins 258, 263 move along their respective cam paths 282, 284 and force the linkages 254, 265 to rotate from the first configuration to the second configuration. In the first configuration, an axis extending across the width W of each linkage 254, 265 is substantially transverse to a longitudinal axis of the implant 200. In the second configuration, the axis extending across the width W of each linkage 254, 265 is nearly or substantially parallel to the longitudinal axis of the implant 200. The upper and lower body portions 202, 204 can only move apart so far as the linkages 254, 265 will permit. As such, the distance between the upper and lower body portions 202, 204 is limited by the distance between far ends of cam paths 282, 284.

**[0108]** Although not shown in the FIGS., the implant 200 can include additional linkages to provide further stability. Each of the additional linkages can connect to the upper and lower body portions 202, 204 as described above. For example, the additional linkages can be horizontally displaced from the first and second linkages 254, 265 described herein. In certain variants, the additional linkages can connect to the first and second linkages 254, 265 to permit further expansion of the upper and lower body portions 202, 204. For



example, the upper and lower body portions 202, 204 can be separated by a distance equivalent to two linkages.

[0109] The specific dimensions of any of the embodiment disclosed herein can be readily varied depending upon the intended application, as will be apparent to those of skill in the art in view of the disclosure herein. Moreover, although the present inventions have been described in terms of certain preferred embodiments, other embodiments of the inventions including variations in the number of parts, dimensions, configuration and materials will be apparent to those of skill in the art in view of the disclosure herein. In addition, all features discussed in connection with any one embodiment herein can be readily adapted for use in other embodiments herein to form various combinations and sub-combinations. The use of different terms or reference numerals for similar features in different embodiments does not imply differences other than those which may be expressly set forth. Accordingly, the present inventions are intended to be described solely by reference to the appended claims, and not limited to the preferred embodiments disclosed herein.

WHAT IS CLAIMED IS:

1. An adjustable spinal fusion intervertebral implant comprising:
  - upper and lower body portions each having proximal and distal surfaces at proximal and distal ends thereof, the proximal and distal surfaces of the upper and lower body portions generally facing each other;
  - a proximal wedge member disposed at the proximal ends of the respective ones of the upper and lower body portions;
  - a distal wedge member disposed at the distal ends of the respective ones of the upper and lower body portions;
  - first and second linkages each connected to the upper and lower body portions; and
  - an actuator shaft received between the upper and lower body portions, the actuator shaft extending intermediate the distal and proximal wedge members, wherein rotation of the actuator shaft causes the distal and proximal wedge members to be drawn together such that longitudinal movement of the distal wedge member against the distal surfaces and the longitudinal movement of the proximal wedge member against the proximal surfaces causes separation of the upper and lower body portions.
2. The implant of Claim 1, wherein the proximal surfaces of the respective ones of the upper and lower body portions each define a proximal slot therein, and distal surfaces of the respective ones of the upper and lower body portions each define a distal slot therein.
3. The implant of Claim 2, wherein the slots of the proximal and distal surfaces of the upper and lower body portions are generally dove-tailed.
4. The implant of Claim 2, wherein the proximal wedge member and the distal wedge member each comprise upper and lower guide members extending at least partially into the respective ones of the proximal and distal slots of the upper and lower body portions with at least a portion of the proximal wedge member and the distal wedge member contacting the proximal and distal surfaces of the upper and lower body portions.
5. The implant of Claim 4, wherein the guide members of the proximal and distal wedge members are generally dovetailed.

6. The implant of Claim 1, wherein each of the upper and lower body portions further comprises a first side portion having an extending portion and a second side portion having a receiving portion, the first side portion of the upper body portion configured to mate with the second side portion of the lower body portion and the second side portion of the upper body portion configured to mate with the first side portion of the lower body portion.

7. The method of Claim 6, wherein the first and second side portions of the upper body portion are configured to disengage from the first and second side portions of the lower body portion when the implant is in an expanded state.

8. The implant of Claim 1, wherein the proximal and distal surfaces of the upper and lower body portions are sloped.

9. The implant of Claim 1, wherein the upper and lower body portions comprise generally arcuate respective upper and lower exterior engagement surfaces.

10. The implant of Claim 1, wherein the proximal wedge member comprises an anti-rotational element, the anti-rotational engagement being configured to be engaged by an implant tool for preventing rotation of the implant when the actuator shaft is rotated relative to the implant.

11. The implant of Claim 9, wherein the anti-rotational element comprises a pair of apertures extending into the proximal wedge member.

12. The implant of Claim 1, wherein the each of the first and second linkages include at least one cam path.

13. The implant of Claim 12, wherein a pin extends from the at least one cam path to one of the upper and lower body portions.

14. The implant of Claim 1, wherein a length of the implant varies from about 45 mm to about 54 mm during the separation of the upper and lower body portions.

15. The implant of Claim 1, wherein a length of the implant varies from about 21 mm to about 31 mm during the separation of the upper and lower body portions.

16. The implant of Claim 1, wherein a height of the implant varies from about 6.5 mm to about 12 mm during the separation of the upper and lower body portions.

17. The implant of Claim 1, wherein the upper and lower body portions are coated with a bio-active coating.

18. The implant of Claim 17, wherein the bio-active coating is a hydroxyapatite coating.

19. A method of manufacturing an adjustable spinal fusion intervertebral implant, the method comprising:

extending an actuator shaft from a proximal wedge member to a distal wedge member;

engaging the proximal and distal wedge members with each of the upper and lower body portions; and

connecting first and second linkages to each of the upper and lower body portions.

20. The method of Claim 19, wherein extending the actuator shaft from the proximal wedge member to the distal wedge member comprises inserting the actuator shaft through a central aperture of the proximal wedge member and through a central aperture of the distal wedge member.

21. The method of Claim 19, wherein engaging the proximal and distal wedge members with each of the upper and lower body portions comprises extending upper and lower guide members of the proximal and distal wedge members at least partially into respective ones of proximal and distal slots of the upper and lower body portions.

22. The method of Claim 19, further comprising engaging a first side portion of the upper body portion and a second side portion of the lower body portion, the first side portion having an extending portion and the second side portion having a receiving portion, the receiving portion configured to receive the extending portion.

23. The method of Claim 18, wherein engaging the first and second linkages with each of the upper and lower body portions comprises extending a pin from a cam path of one of the first and second linkages to one of the upper and lower body portions.

24. The method of Claim 19, further comprising shot-peening the upper and lower body portions.

25. The method of Claim 19, further comprising coating the upper and lower body portions with a bio-active coating.

26. The method of Claim 25, wherein the bio-active coating is a hydroxyapatite coating.

27. A method of implanting an expandable intervertebral implant comprising:  
positioning the implant between two vertebral bodies;  
rotating a screw mechanism of the implant to cause proximal and distal wedge members to converge toward each other and engage respective ones of proximal and distal surfaces of upper and lower body portions of the implant;  
separating the upper and lower body portions to cause the implant to expand, wherein separating the upper and lower body portions causes first and second linkages to rotate from a first configuration to a second configuration.
28. The method of Claim 27, wherein a height of the first and second linkages is greater in the second configuration than in the first configuration.
29. The method of Claim 27, further comprising moving one or more pins along a respective cam path of one of the first and second linkages to cause the first and second linkages to rotate from the first configuration to the second configuration.

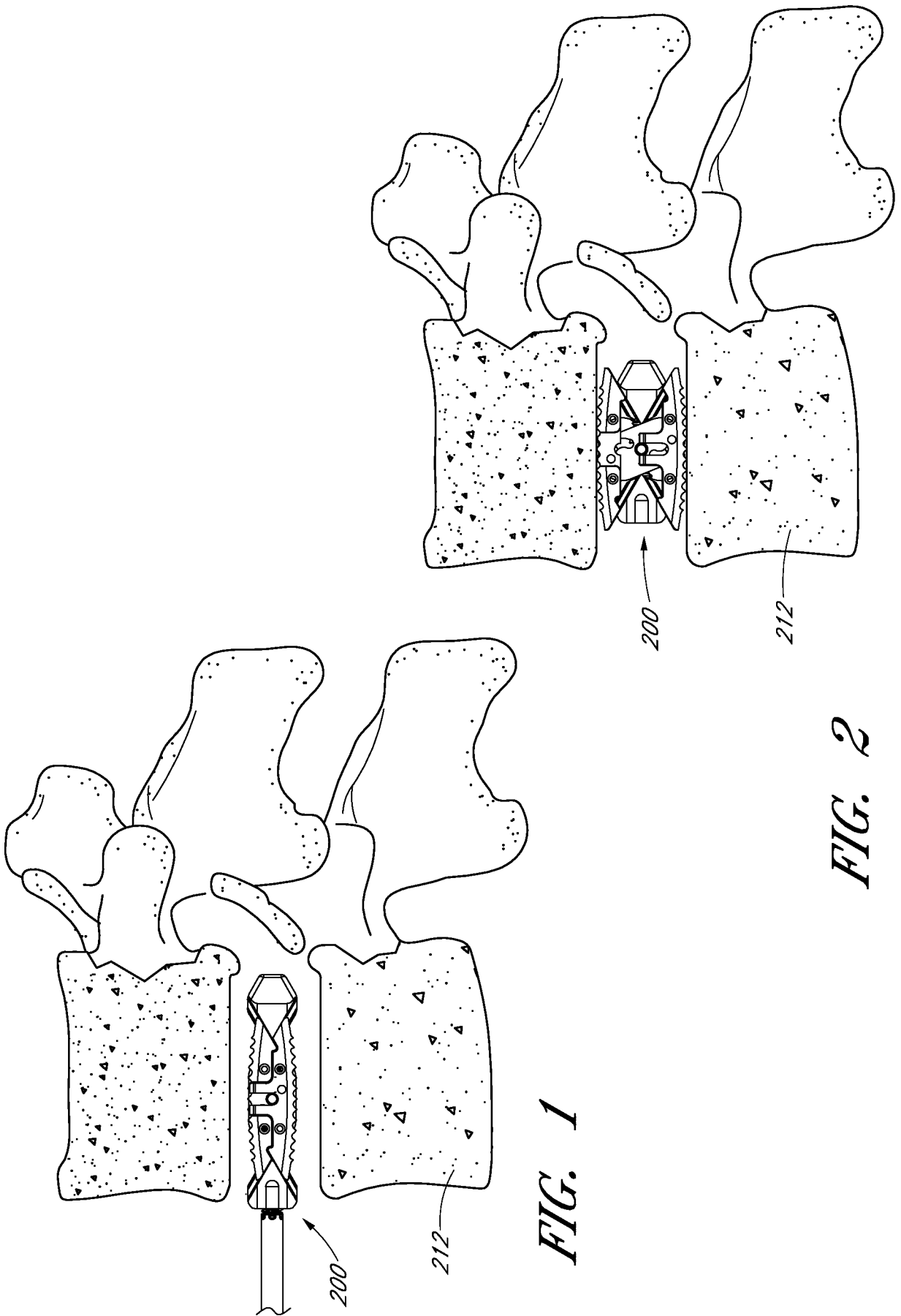


FIG. 1

FIG. 2

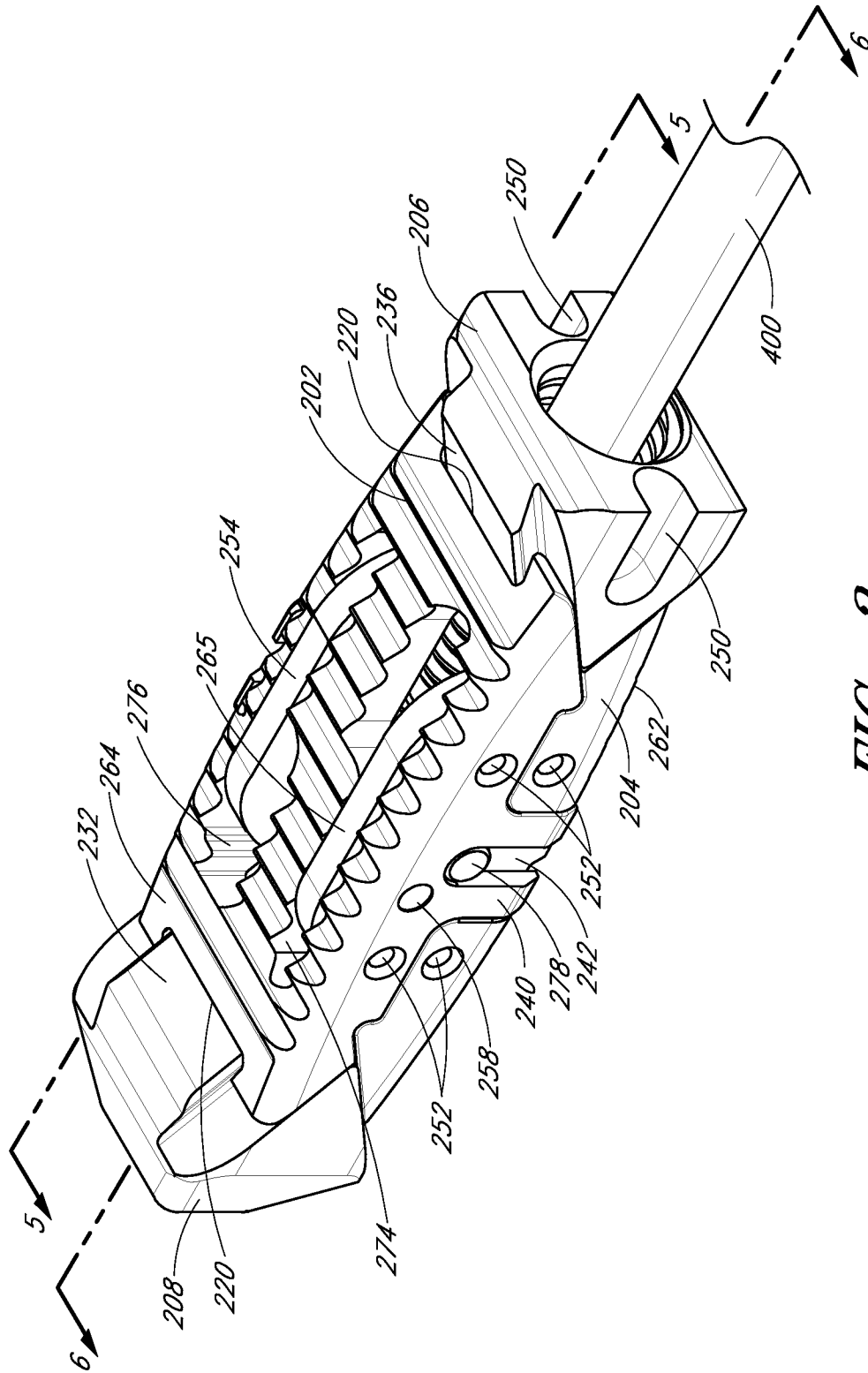


FIG. 3

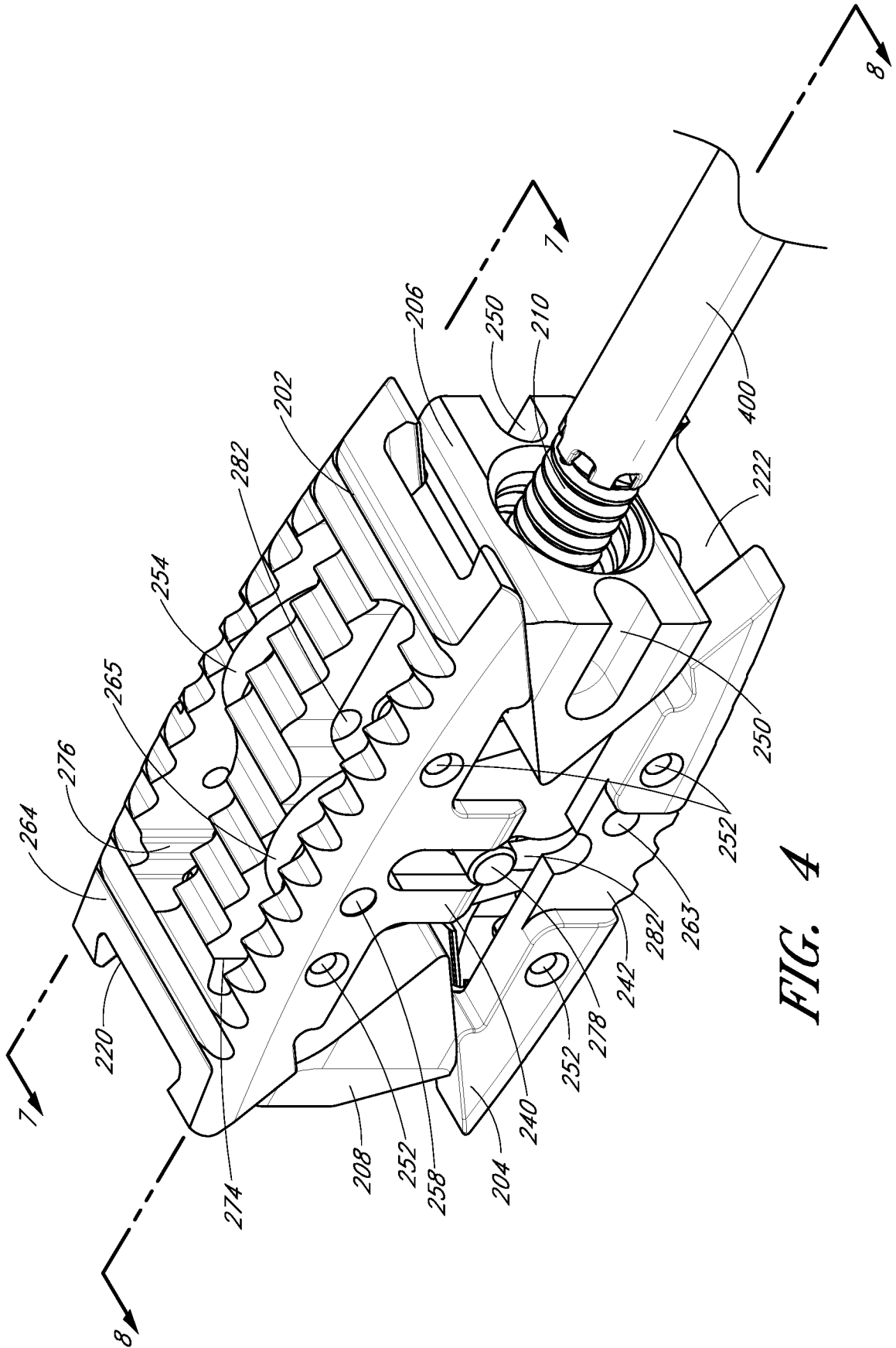


FIG. 4



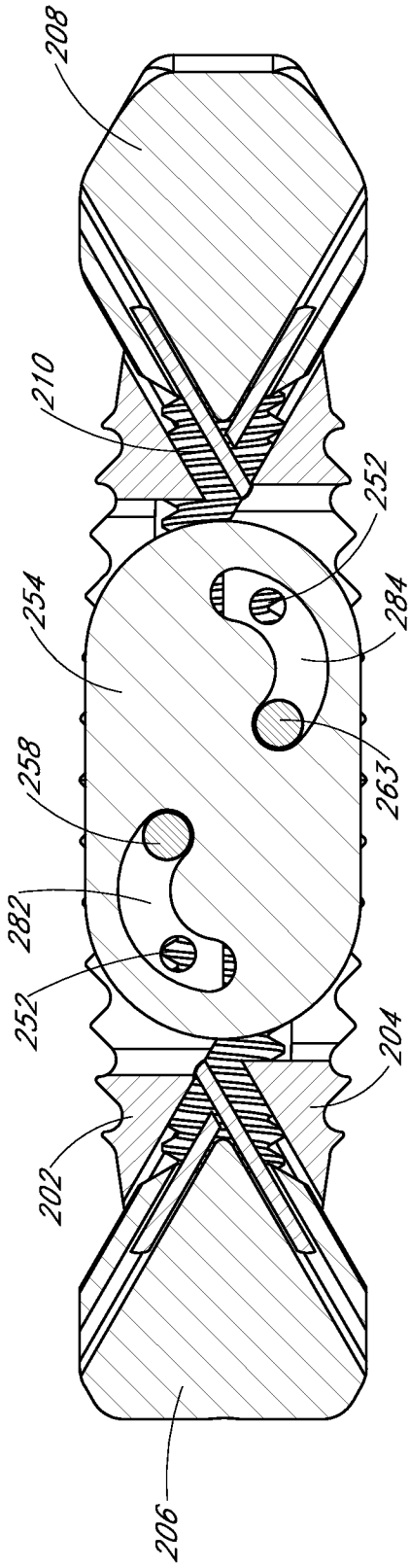


FIG. 5

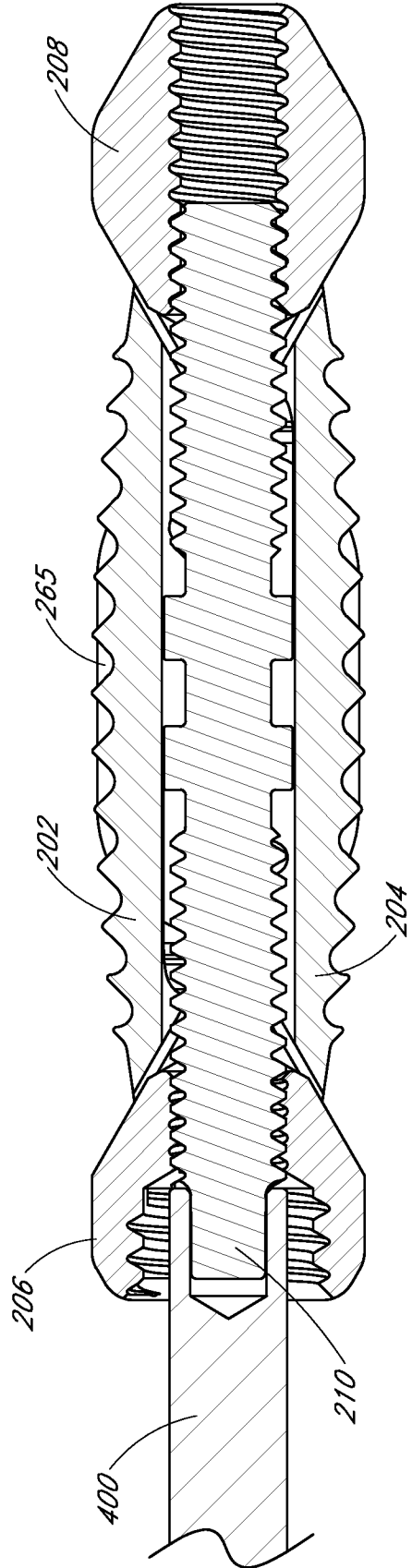


FIG. 6

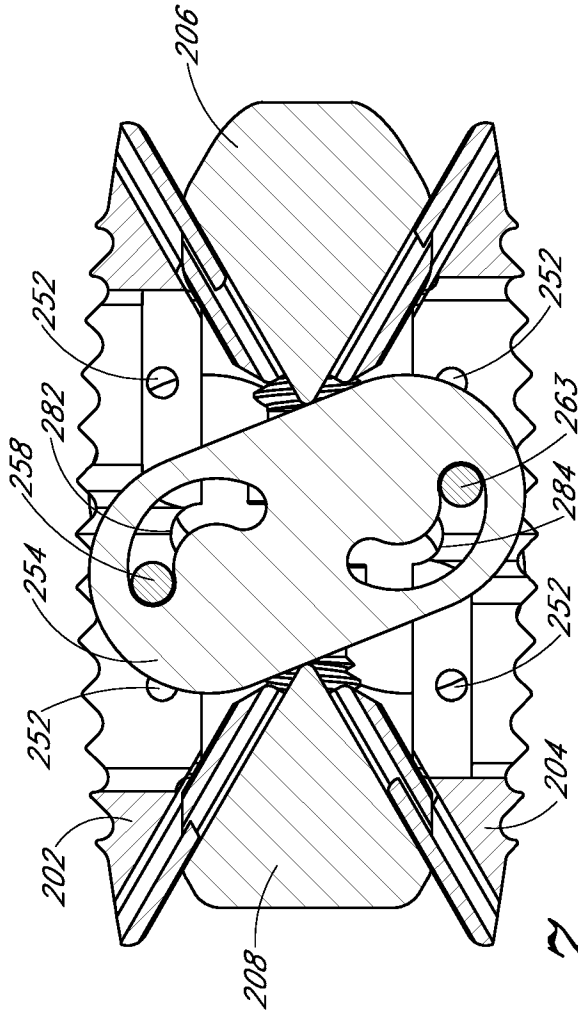


FIG. 7

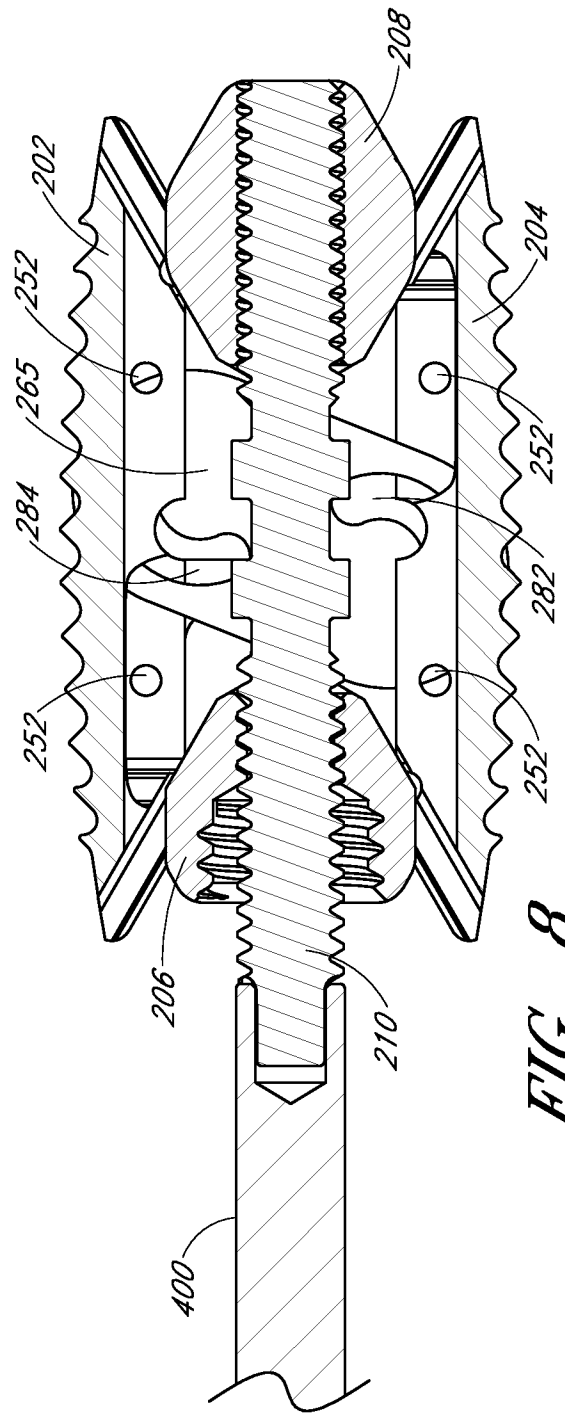
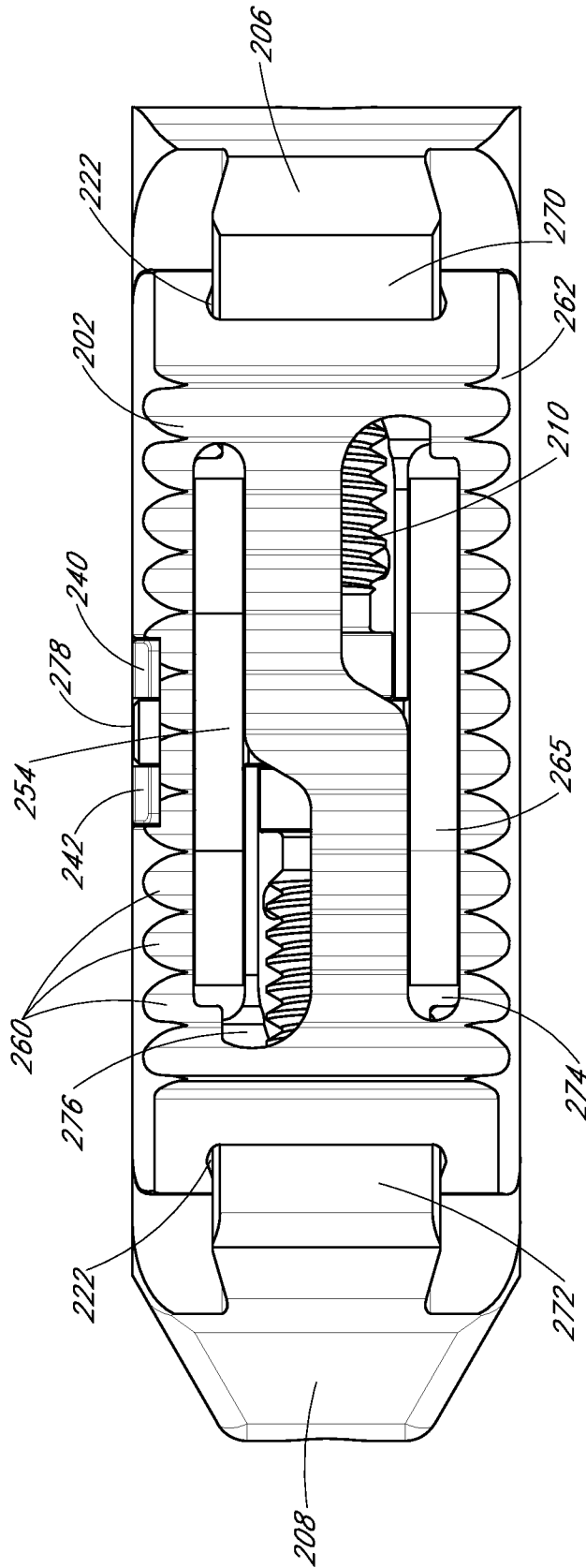


FIG. 8



*FIG. 9*

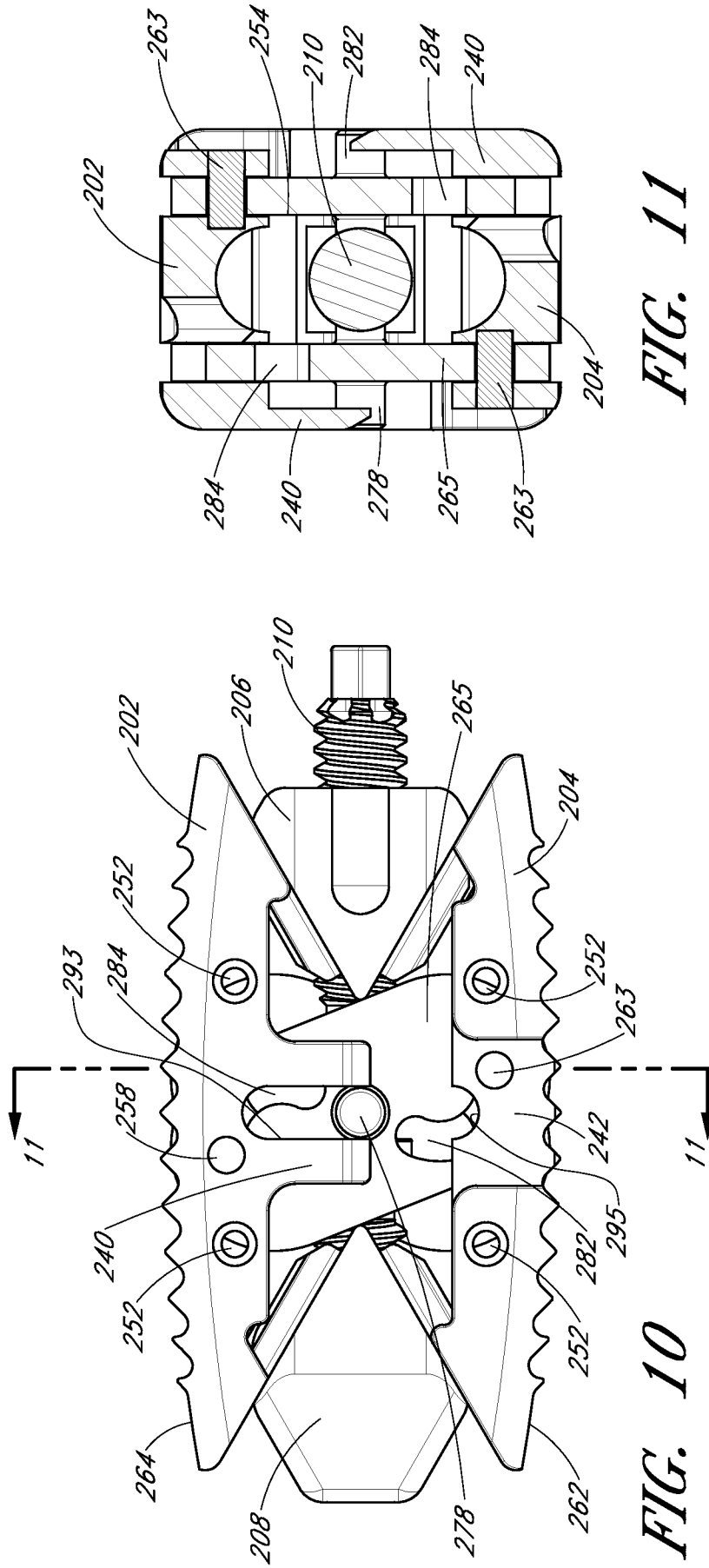


FIG. 11

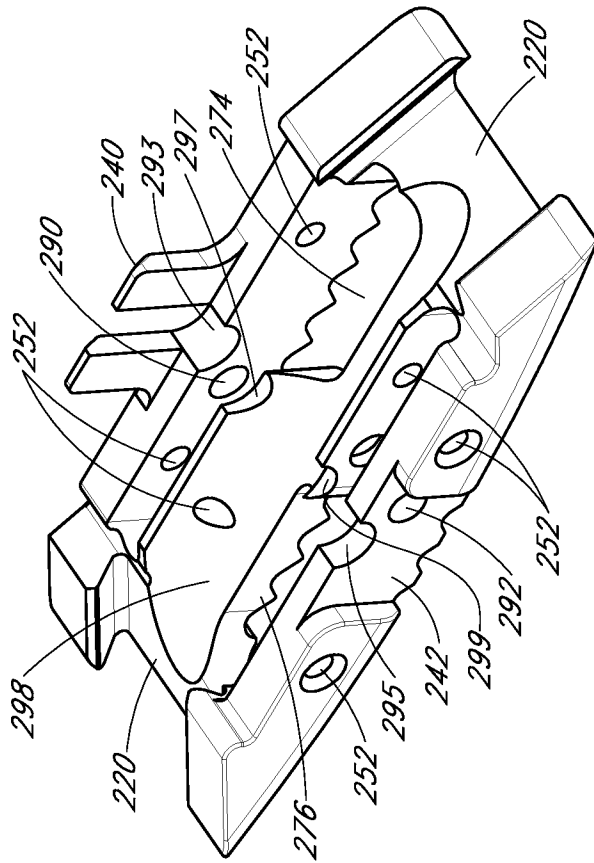


FIG. 12

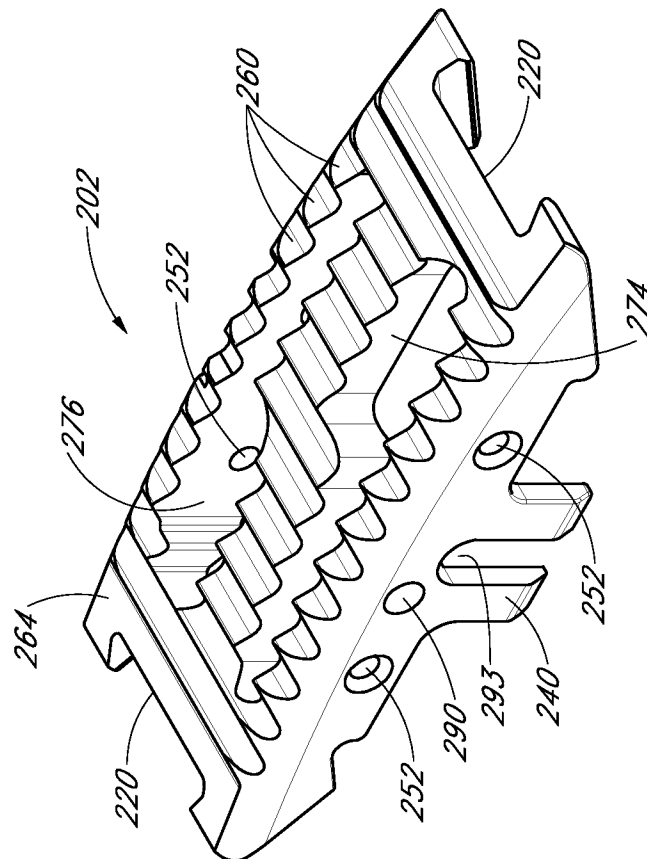
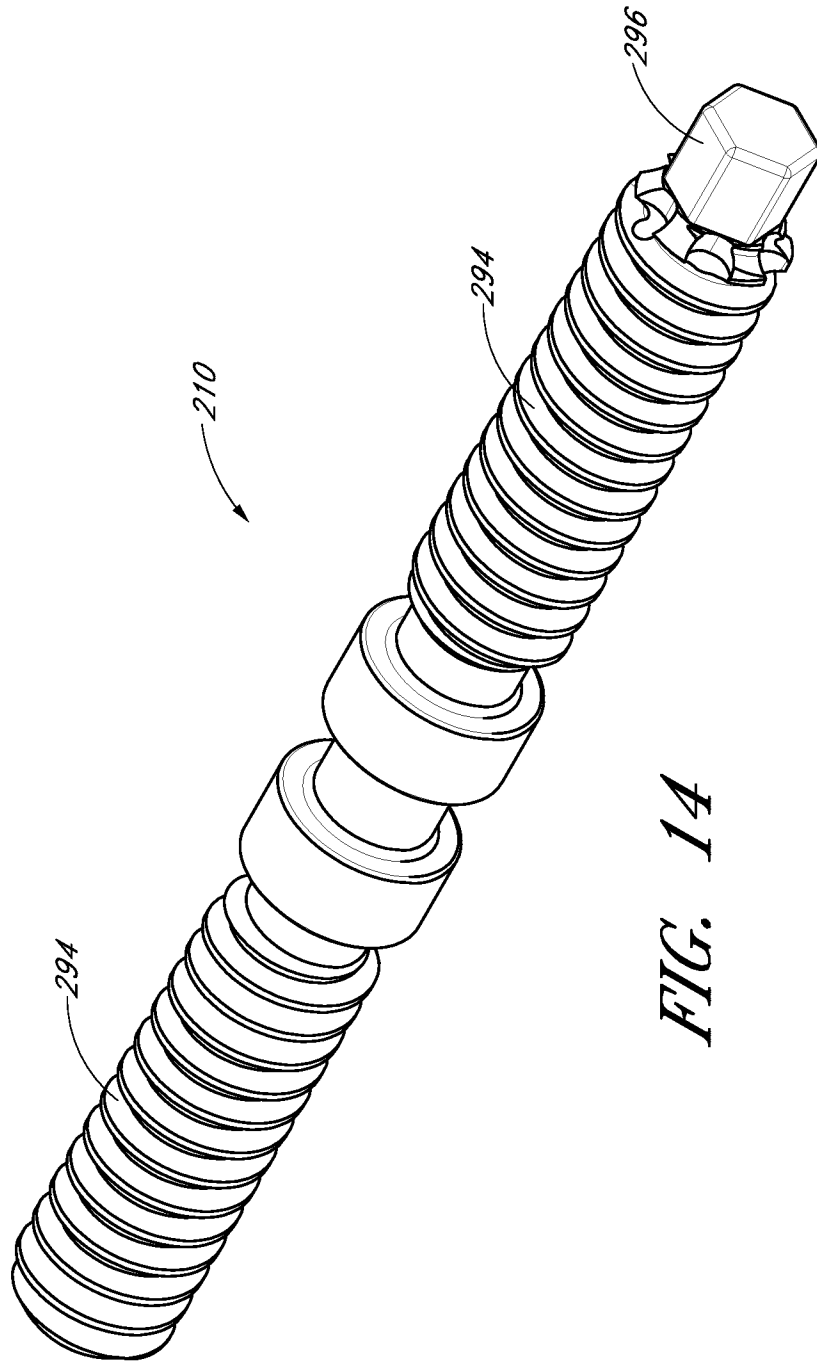
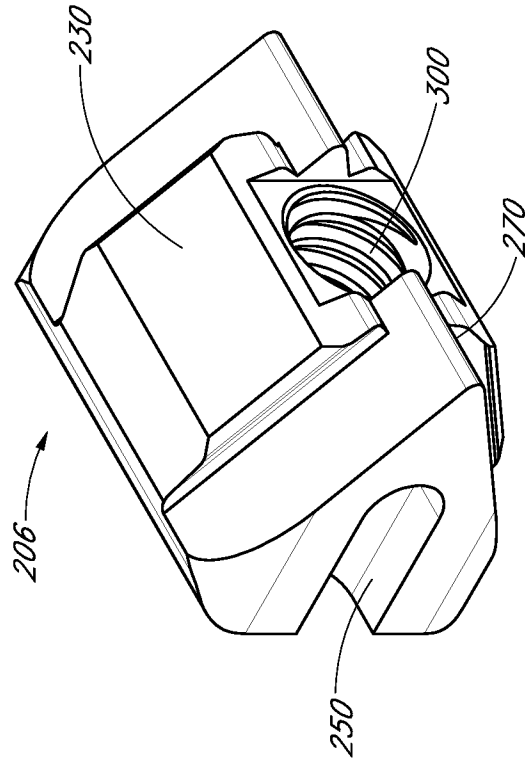


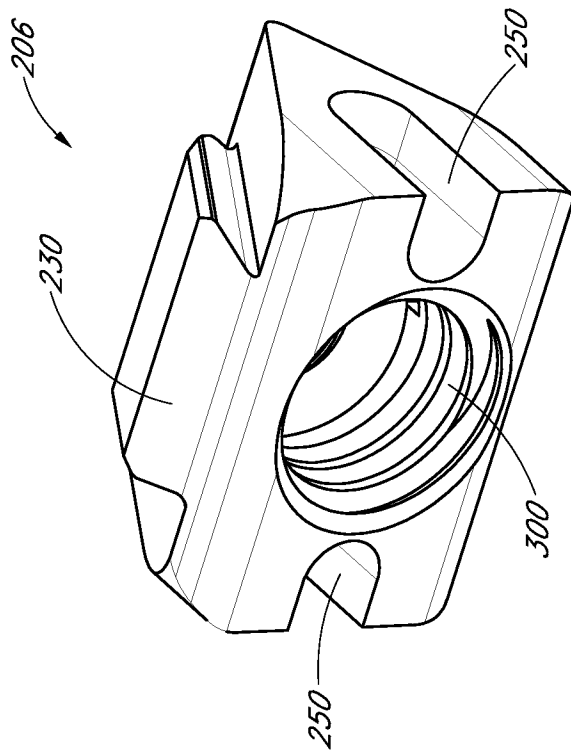
FIG. 13



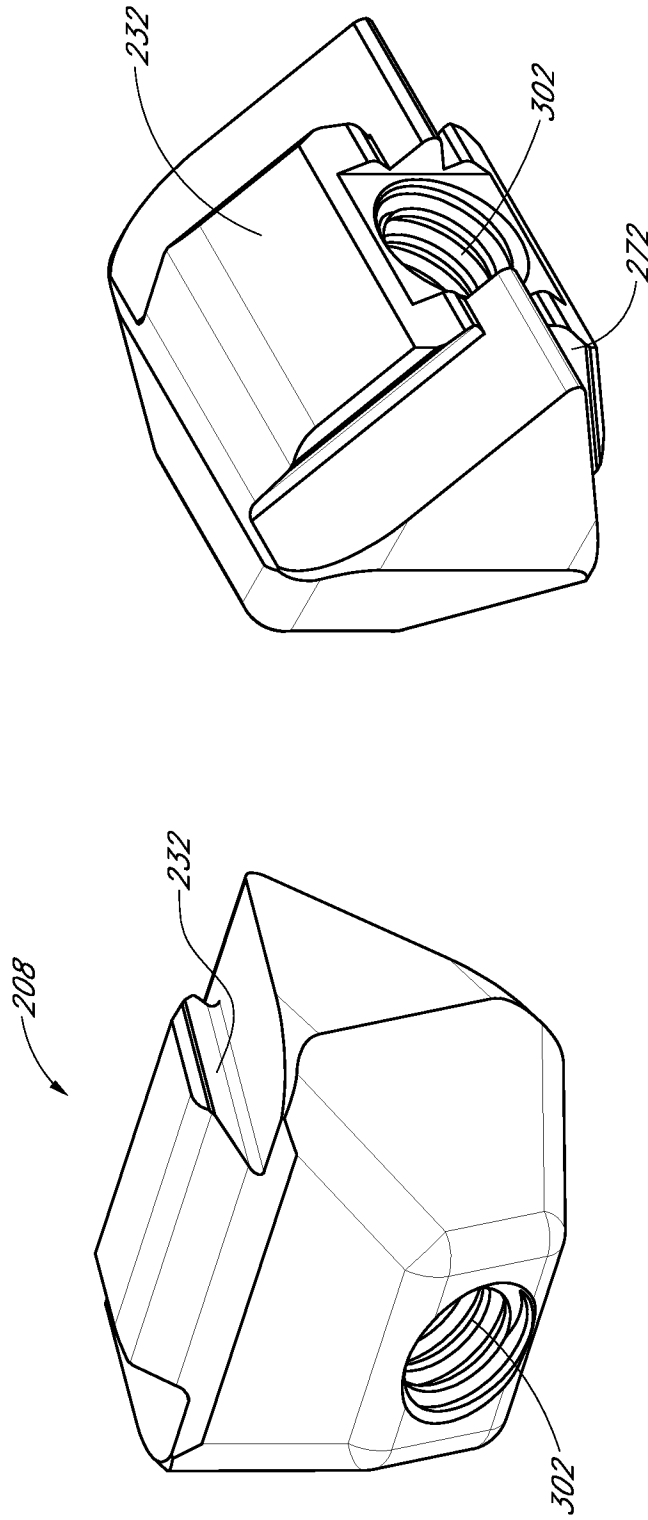
**FIG. 14**



*FIG. 15*



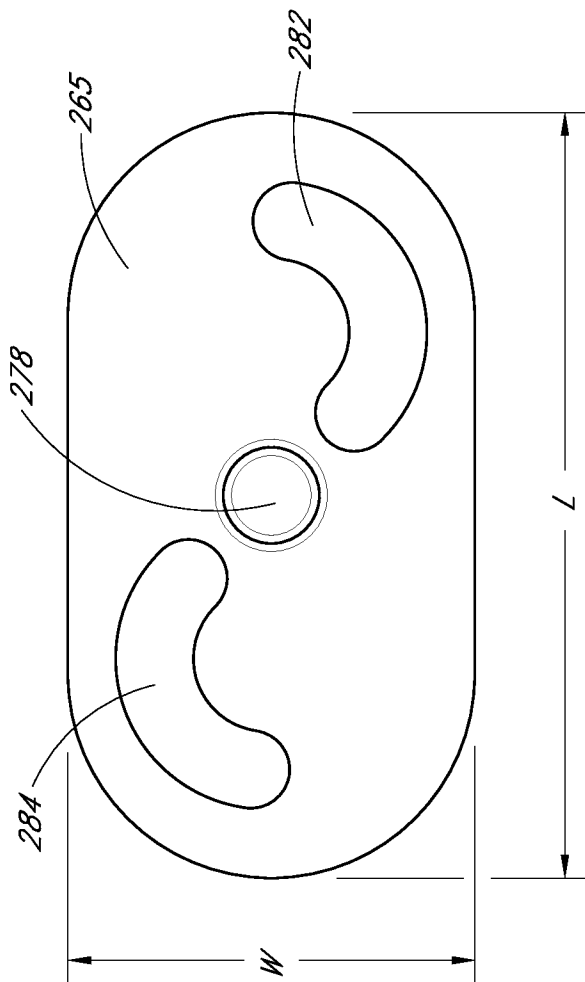
*FIG. 16*



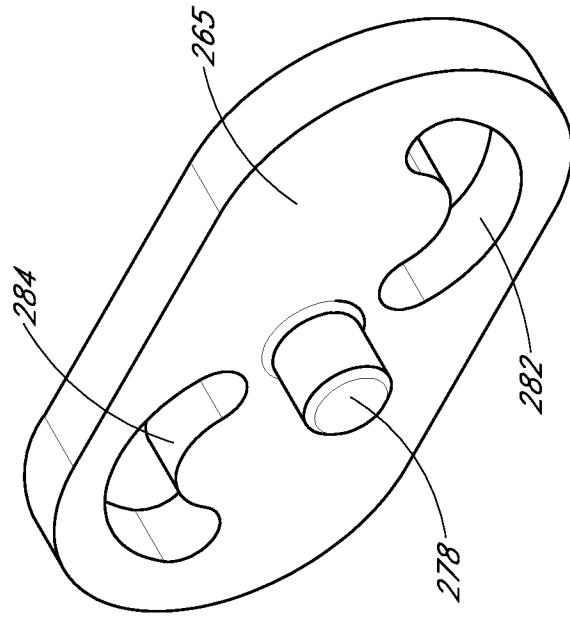
*FIG. 18*

*FIG. 17*

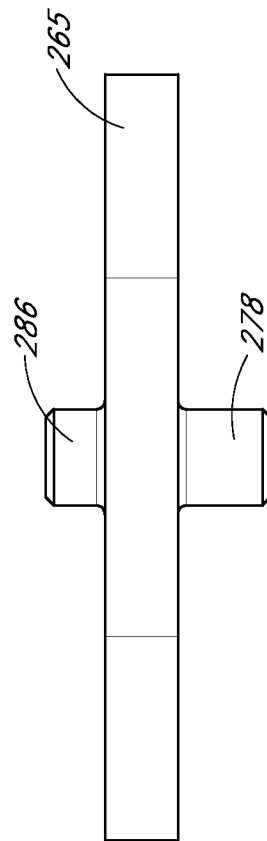




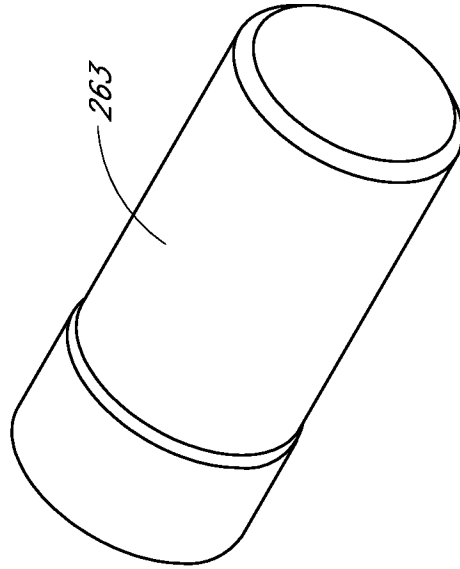
*FIG. 19B*



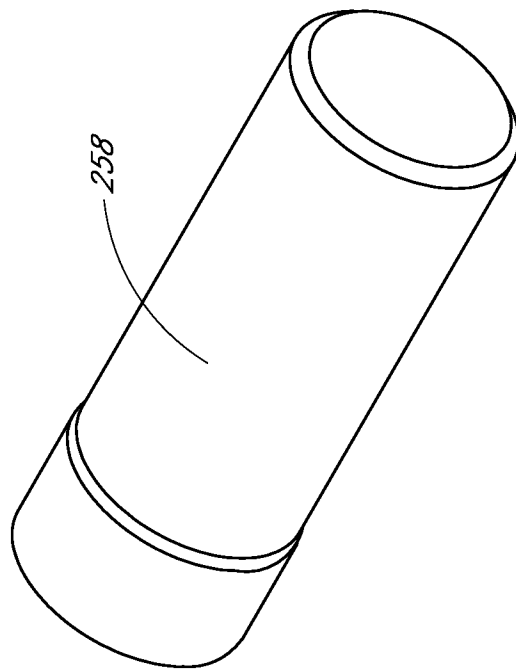
*FIG. 19A*





*FIG. 19C*



*FIG. 21*



*FIG. 20*

<b>A. CLASSIFICATION OF SUBJECT MATTER</b> <b>A61F 2/44(2006.01)i, A61B 17/70(2006.01)i</b>		
According to International Patent Classification (IPC) or to both national classification and IPC		
<b>B. FIELDS SEARCHED</b>		
Minimum documentation searched (classification system followed by classification symbols) A61F 2/44; A61B 17/88; A61B 17/70		
Documentation searched other than minimum documentation to the extent that such documents are included in the fields searched Korean utility models and applications for utility models Japanese utility models and applications for utility models		
Electronic data base consulted during the international search (name of data base and, where practicable, search terms used) eKOMPASS(KIPO internal) & Keywords: intervertebral, implant, body, wedge, linkage, actuator, shaft, slot, guide member, dove-tail, anti-rotation, anti-torque, aperture		
<b>C. DOCUMENTS CONSIDERED TO BE RELEVANT</b>		
Category*	Citation of document, with indication, where appropriate, of the relevant passages	Relevant to claim No.
X	US 2012-0191194 A1 (OLMOS, F. et al.) 26 July 2012 See claims 2, 11; paragraphs [0024]-[0178]; figures 16A-24B.	1-11, 14-22, 24-26
A		12-13, 23
A	US 2012-0185049 A1 (VARELA, A.) 19 July 2012 See abstract; paragraphs [0062]-[0065]; figures 1-3.	1-26
A	US 8366777 B2 (MATTHIS, W. et al.) 05 February 2013 See claim 1; columns 3-4; figures 1-2.	1-26
A	US 8231675 B2 (RHODA, W. S.) 31 July 2012 See the whole document.	1-26
A	US 8257440 B2 (GORDON, C. R. et al.) 04 September 2012 See the whole document.	1-26
<input type="checkbox"/> Further documents are listed in the continuation of Box C. <input checked="" type="checkbox"/> See patent family annex.		
* Special categories of cited documents: "A" document defining the general state of the art which is not considered to be of particular relevance "E" earlier application or patent but published on or after the international filing date "L" document which may throw doubts on priority claim(s) or which is cited to establish the publication date of another citation or other special reason (as specified) "O" document referring to an oral disclosure, use, exhibition or other means "P" document published prior to the international filing date but later than the priority date claimed		"T" later document published after the international filing date or priority date and not in conflict with the application but cited to understand the principle or theory underlying the invention "X" document of particular relevance; the claimed invention cannot be considered novel or cannot be considered to involve an inventive step when the document is taken alone "Y" document of particular relevance; the claimed invention cannot be considered to involve an inventive step when the document is combined with one or more other such documents, such combination being obvious to a person skilled in the art "&" document member of the same patent family
Date of the actual completion of the international search 27 June 2014 (27.06.2014)		Date of mailing of the international search report <b>01 July 2014 (01.07.2014)</b>
Name and mailing address of the ISA/KR  International Application Division Korean Intellectual Property Office 189 Cheongsa-ro, Seo-gu, Daejeon Metropolitan City, 302-701, Republic of Korea Facsimile No. +82-42-472-7140		Authorized officer Han, Inho Telephone No. +82-42-481-3362 

**Box No. II Observations where certain claims were found unsearchable (Continuation of item 2 of first sheet)**

This international search report has not been established in respect of certain claims under Article 17(2)(a) for the following reasons:

1.  Claims Nos.: 27-29  
because they relate to subject matter not required to be searched by this Authority, namely:  
Claims 27-29 pertain to a method for treatment of the human body by surgery, and thus relate to a subject matter which this International Searching Authority is not required, under Article 17(2)(a)(i) of the PCT and Rule 39.1(iv) of the Regulations under the PCT, to search.
2.  Claims Nos.:  
because they relate to parts of the international application that do not comply with the prescribed requirements to such an extent that no meaningful international search can be carried out, specifically:
3.  Claims Nos.:  
because they are dependent claims and are not drafted in accordance with the second and third sentences of Rule 6.4(a).

**Box No. III Observations where unity of invention is lacking (Continuation of item 3 of first sheet)**

This International Searching Authority found multiple inventions in this international application, as follows:

1.  As all required additional search fees were timely paid by the applicant, this international search report covers all searchable claims.
2.  As all searchable claims could be searched without effort justifying an additional fees, this Authority did not invite payment of any additional fees.
3.  As only some of the required additional search fees were timely paid by the applicant, this international search report covers only those claims for which fees were paid, specifically claims Nos.:
  
4.  No required additional search fees were timely paid by the applicant. Consequently, this international search report is restricted to the invention first mentioned in the claims; it is covered by claims Nos.:

**Remark on Protest**

- The additional search fees were accompanied by the applicant's protest and, where applicable, the payment of a protest fee.
- The additional search fees were accompanied by the applicant's protest but the applicable protest fee was not paid within the time limit specified in the invitation.
- No protest accompanied the payment of additional search fees.

**INTERNATIONAL SEARCH REPORT**

Information on patent family members

International application No.

**PCT/US2014/019657**

Patent document cited in search report	Publication date	Patent family member(s)	Publication date
US 2012-0191194 A1	26/07/2012	US 2008-140207 A1 US 2013-231747 A1 US 8105382 B2 US 8568481 B2 WO 2008-070863 A2	12/06/2008 05/09/2013 31/01/2012 29/10/2013 12/06/2008
US 2012-0185049 A1	19/07/2012	US 2012-0226357 A1 WO 2013-148176 A1	06/09/2012 03/10/2013
US 8366777 B2	05/02/2013	EP 1925272 A1 JP 2008-126085 A JP 2013-222536 B2 KR 10-2008-0047276 A US 2008-0147193 A1 US 2013-0173003 A1 US 8702798 B2	28/05/2008 05/06/2008 26/06/2013 28/05/2008 19/06/2008 04/07/2013 22/04/2014
US 8231675 B2	31/07/2012	AU 2003-303195 A1 CA 2511086 A1 CN 1747696 A EP 1587460 A2 JP 2006-510446 A JP 2010-594738 B2 KR 10-1072743 B1 KR 10-2005-0112075 A US 2004-0122518 A1 US 2008-0161922 A1 US 7192447 B2 US 8597356 B2 WO 2004-056289 A2	14/07/2004 08/07/2004 15/03/2006 26/10/2005 30/03/2006 08/12/2010 11/10/2011 29/11/2005 24/06/2004 03/07/2008 20/03/2007 03/12/2013 08/07/2004
US 8257440 B2	04/09/2012	AU 2007-223025 A1 EP 1996101 A2 JP 2009-538155 A US 2005-0033431 A1 US 2005-0033432 A1 US 2005-0033439 A1 US 2005-0209698 A1 US 2005-0273171 A1 US 2005-0273173 A1 US 2005-0273174 A1 US 2005-0273175 A1 US 2005-0278026 A1 US 2005-0283244 A1 US 2005-0283245 A1 US 2005-0283247 A1 US 2005-0283248 A1 US 2006-0195192 A1 US 2006-0229729 A1	13/09/2007 03/12/2008 05/11/2009 10/02/2005 10/02/2005 10/02/2005 22/09/2005 08/12/2005 08/12/2005 08/12/2005 08/12/2005 15/12/2005 22/12/2005 22/12/2005 22/12/2005 22/12/2005 22/12/2005 31/08/2006 12/10/2006

**INTERNATIONAL SEARCH REPORT**

Information on patent family members

International application No.

**PCT/US2014/019657**

Patent document cited in search report	Publication date	Patent family member(s)	Publication date
		US 2006-0241769 A1	26/10/2006
		US 2006-0241771 A1	26/10/2006
		US 2006-0247635 A1	02/11/2006
		US 2006-0247779 A1	02/11/2006
		US 2007-0073406 A1	29/03/2007
		US 2007-0213720 A1	13/09/2007
		US 2007-0270972 A1	22/11/2007
		US 2010-0331985 A1	30/12/2010
		WO 2005-016194 A2	24/02/2005
		WO 2007-104024 A2	13/09/2007