

(No Model.)

C. C. CHESNEY.
CIRCUIT BREAKER.

No. 525,134.

Patented Aug. 28, 1894.

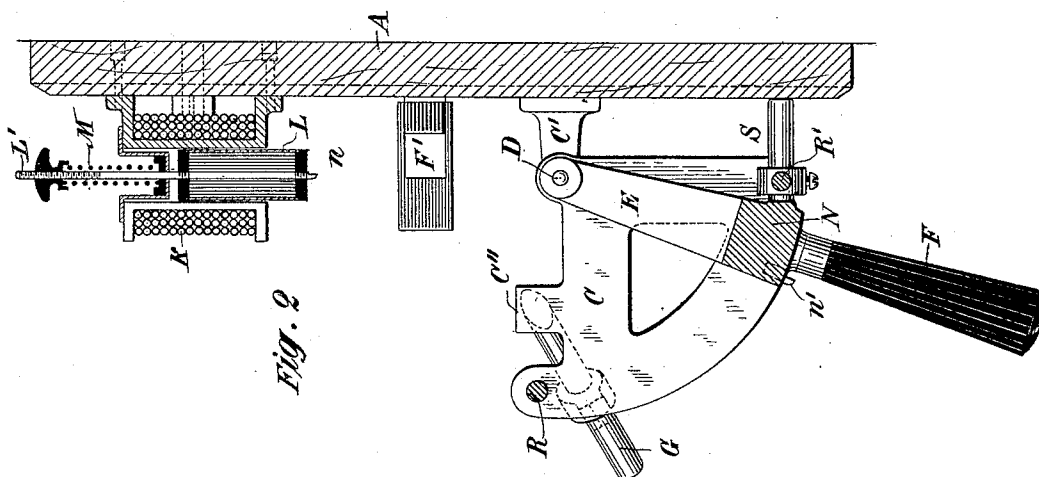

FIG. 2

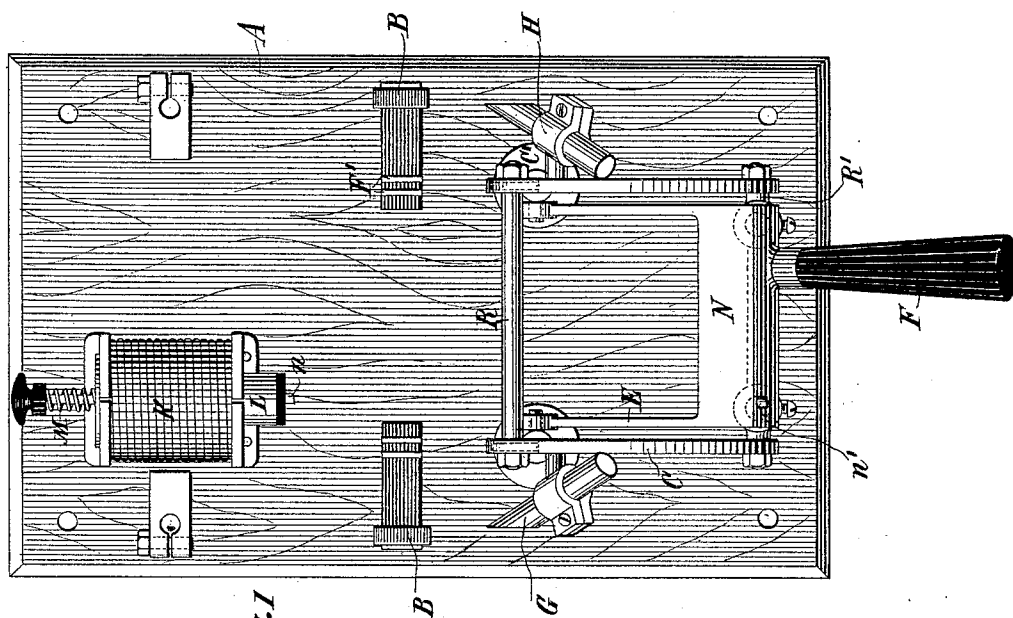

FIG. 1

Witnesses:
Raphael Netter
James W. Catlow

Inventor
Cummings C. Chesney
by *Dureau & Page*,
Attorneys.

UNITED STATES PATENT OFFICE.

CUMMINGS C. CHESNEY, OF PITTSFIELD, MASSACHUSETTS, ASSIGNOR TO
THE STANLEY LABORATORY COMPANY, OF SAME PLACE.

CIRCUIT-BREAKER.

SPECIFICATION forming part of Letters Patent No. 525,134, dated August 28, 1894.

Application filed July 6, 1894. Serial No. 516,751. (No model.)

To all whom it may concern:

Be it known that I, CUMMINGS C. CHESNEY, a citizen of the United States, residing at Pittsfield, in the county of Berkshire and State of Massachusetts, have invented certain new and useful Improvements in Circuit-Breakers, of which the following is a specification, reference being had to the drawings accompanying and forming a part of the same.

10 This invention is an improvement in automatically operating circuit breakers or cut-outs for circuits carrying powerful currents, and its object is to provide a device for this purpose, which may be simple in construction and safe and accurate in action.

15 The improvement comprises the combination with the terminals of a break in a circuit and a swinging or pivoted bridge-piece for connecting the same to complete the circuit, of a weight or weighted lever engaging with the bridge piece but capable of a certain free or lost motion relatively to the same, whereby it may, when released for the purpose of interrupting the circuit, fall by gravity and acquire a sufficient momentum to instantly and positively separate the bridge piece from the terminals at the moment of engagement with the bridge-piece. These parts, moreover, are distinguished by certain novel features of construction and arrangement which will be hereinafter more fully set forth.

25 The invention also includes the combination with the swinging bridge piece or circuit-breaking lever and the weighted lever above described of carbon points or pencils arranged to form a high resistance path for the circuit for a short interval after the separation of the main contact points, and thus avoid sparking.

30 The improvements forming the subject of my invention will be described in detail by reference to the accompanying drawings, in which—

45 Figure 1 is a plan view in elevation and Fig. 2, a side view in section of my improved circuit breaker or cut-out.

50 The operative portions of the apparatus are mounted upon any suitable base A, generally of insulating material, upon which are the

terminal contacts B B of a break in any circuit with which the apparatus is to be used. These terminals are bridged and the break in the circuit closed by a bridge-piece consisting of a metal frame C pivoted to any suitable supports or standards C' at the point D. When this frame bridges the terminals B its sides C or projections C'' thereon are forced between spring plates F' on the terminals B. The apparatus is used with the base in a vertical position and the friction between the projections C'' and the contact plates F' is sufficient to maintain the frame C in contact with the terminals against all ordinary jars to which the apparatus is likely to be subjected.

60 Pivoted to the axis D is a second frame E having a heavily weighted portion N at its free end. An insulating handle F is inserted in the weighted portion N and to complete the circuit said handle is raised until the weighted portion N engages with a bar R extending across the frame C. This engagement takes place when the handle is brought to approximately the horizontal position and by raising the handle to the vertical position the frame C is turned about its pivotal support until the projections C'' are forced firmly between the contact plates or springs F'. The handle and weight are held in the vertical position by any suitable catch, in this case, the catch shown being an ordinary tripping magnet K having a core L adjustable by means of a stem L' and a spiral spring M surrounding the same. A small projection n at the bottom of the core of the magnet engages with a corresponding projection n' on the weight or weighted portion N and the weight when thus engaged remains very slightly out of the vertical position with a tendency to fall. When the magnet is energized or when energized beyond a certain predetermined limit, either by the current of the circuit through the terminals and the frame C, or any portion of such current or by the current of any other circuit that may be desired, the core L is raised and the weight N released. By the time the weight reaches the horizontal position it encounters a bar R' in the frame C with sufficient force to dislodge the frame

from engagement with the plates F' and forces it downward into the position shown in the figures where it is checked by any suitable stops as S. In this movement the bridge retreats to a safe distance away from the terminals to prevent the continuance of an arc, but in order to prevent the destructive spark which occurs at the instant of breaking I secure to small holders H carried by one of the two elements which constitute the circuit breaker and preferably to the frame C, carbon rods or pencils G, the ends of which are beveled and adapted to slide in contact with some portion of the surface of the terminals B B. The pencils are of such length or are so adjusted in their holders as to leave the terminals B after contact between the same and the sides of frame C has been interrupted so that for an instant the electrical connection between the terminals is maintained through the carbon pencils. Such path is of higher resistance than that through the frame C and the carbon points, moreover, serve to prevent or to lessen the spark which tends to form on the separation of the contact points. This apparatus is applicable generally to the protection of electric circuits from overloading or charges of abnormal and dangerous strength and in its operation and mode of application it is similar to other devices of this kind heretofore in use.

My invention resides in the special construction and arrangement of the parts hereinbefore described and more particularly specified in the following claims.

I claim—

1. The combination with the terminal plates or contacts of an electric circuit, of a pivoted bridge-piece adapted to be forced and maintained in engagement with said terminals, a pivoted weight engaging with the bridge-piece but having a determined range of movement independent of the same, and a tripping device for holding the weight in an elevated position against the force of gravity, as set forth.

2. The combination with the terminal plates or contacts of an electric circuit, of a metallic frame C, pivoted below the same and adapted to be forced and maintained by friction in engagement with the said terminals, a pivoted weighted frame E engaging with frame C but having a determined range of movement independent of the same, and a tripping magnet for retaining the weighted frame in an elevated position against the force of gravity, as set forth.

3. The combination with the circuit terminals, of a pivoted bridge-piece or frame, a weighted frame or lever engaging therewith but having a determined range of movement independent thereof, a tripping magnet for retaining the weighted lever in an elevated position against the force of gravity, and carbon pencils secured to the frame in position to engage with the terminals during and for a short time after the engagement and separation of the frame and terminals as set forth.

CUMMINGS C. CHESNEY.

Witnesses:

JOHN F. KELLY,
C. B. TOBEY.