

W. S. HUDSON:

Improvement in Locomotives.

No. 129,229.

Patented July 16, 1872.

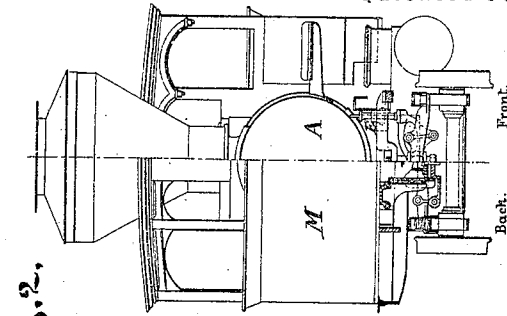

Fig. 2.

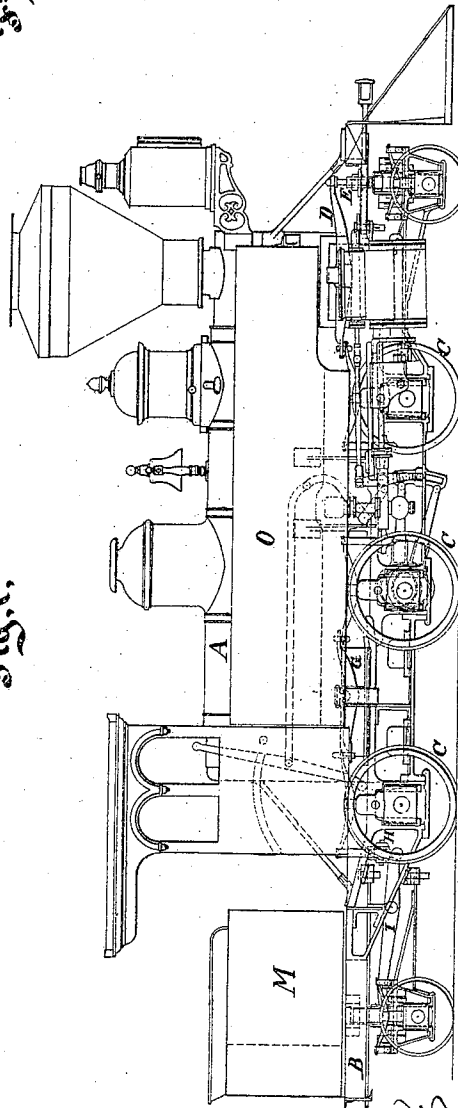

Fig. 1.

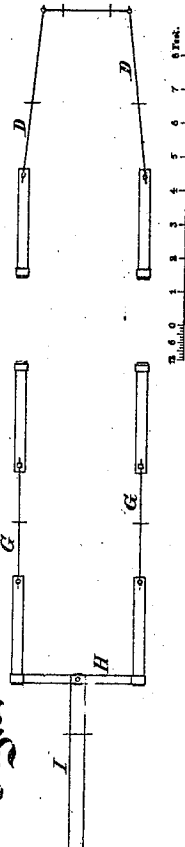

Fig. 3.

Inventor.

W. S. Hudson  
 by his atty *[Signature]*

Witnesses,  
*Arnold Hoernsman.*  
*C. L. Livings*

W. S. HUDSON.

Improvement in Locomotives.

No. 129,229.

Patented July 16, 1872.

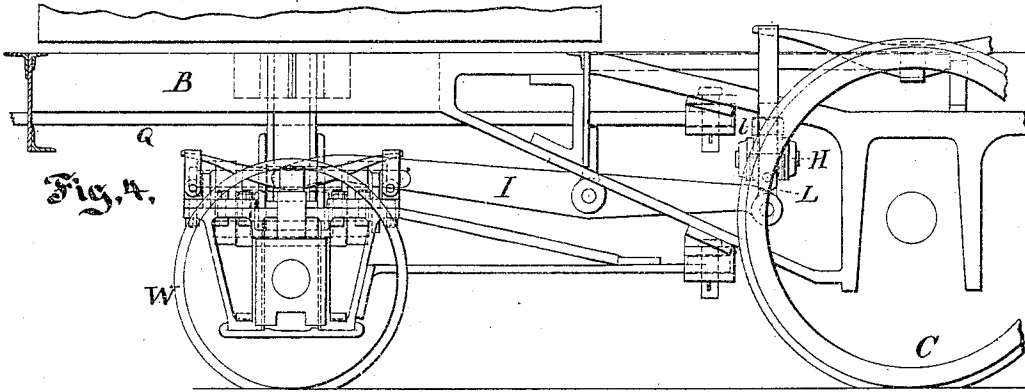

Fig. 4.

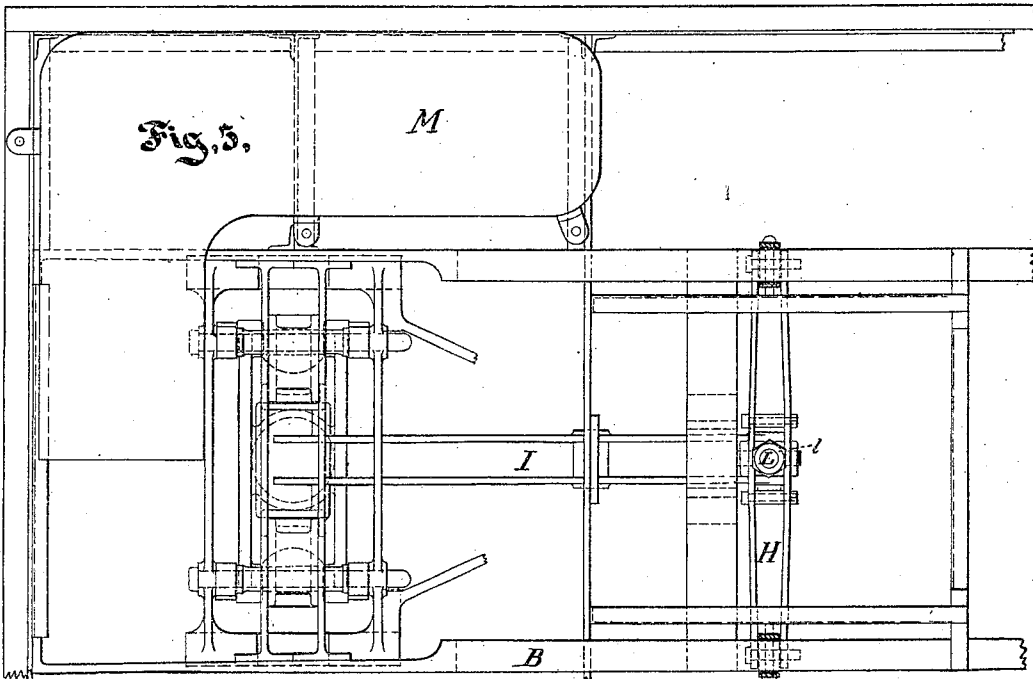

Fig. 5.

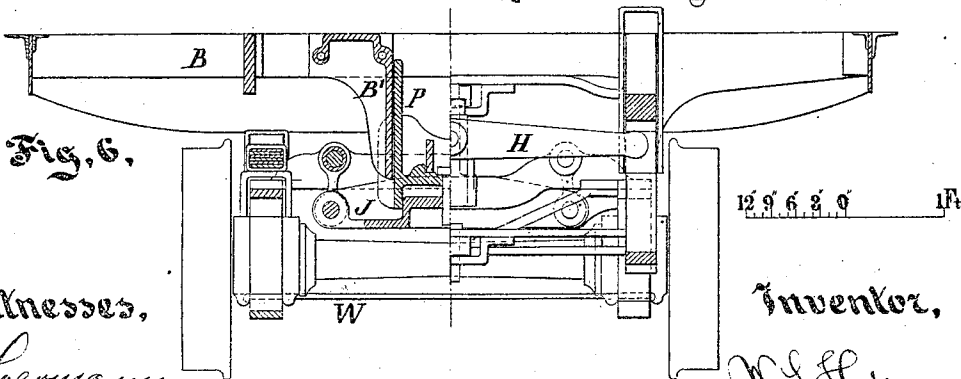

Fig. 6.

Witnesses,  
A. Hoermann.

C. C. Livings

129,229

Inventor,

W. S. Hudson  
by his attorney  
J. S. Stevens

# UNITED STATES PATENT OFFICE.

WILLIAM S. HUDSON, OF PATERSON, NEW JERSEY.

## IMPROVEMENT IN LOCOMOTIVES.

Specification forming part of Letters Patent No. 129,229, dated July 16, 1872.

Specification describing certain Improvements in Locomotives, invented by Wm. S. HUDSON, of Paterson, in the county of Passaic and State of New Jersey.

The invention relates to the employment of a central block over a truck, and certain guides for the same carried on the main framing; also, to the open construction of the said block, and the arrangement of the draw-bar to play through it; to means for raising or lowering at certain points to better adjust the position of the mass upon the supporting-springs; and to the combination of certain side and end tanks with the main body of the locomotive.

The following is a description of what I consider the best means of carrying out the invention:

The accompanying drawing forms a part of this specification.

Figure 1 is a side elevation, and Fig. 2 an end elevation, the right-hand side being an elevation of the front end and the left-hand side an elevation of the rear end of the entire structure.

The machine being symmetrical this compound elevation is equivalent, as is well understood, to a complete front and a complete rear elevation.

Fig. 3 is a diagram, showing in plan view the arrangement of the bearing-springs, equalizing-levers, and swing-beam which serves as a partial cross-equalizer at the front.

The remaining figures are on a larger scale, and show a portion of the work at the rear alone.

Fig. 4 is a side elevation, Fig. 5 is a plan view, and Fig. 6 is a front elevation of the rear parts partly in section.

The left half of the figure is a vertical section in the plane of the central vertical pivot or pintle.

Similar letters of reference indicate like parts in all the figures.

The improvement may be applied to all the class of locomotives in which the rigid frame is extended rearward and made to support or form a part of the tender. There is a half-truck under the tender, which is adapted to both swivel and move from side to side. There is a truck or half truck composed of one pair of wheels only in the front of the locomotive. There are equalizing-levers distributing the

shocks between the forward driving-wheels and the half truck at the front, and another set distributing the shocks between the rear drivers and the half truck at the rear.

A is a boiler and its fixed attachments, which may be in the ordinary form. B is the fixed frame connected thereto in the ordinary manner and adapted to perform its ordinary functions of properly sustaining the wheel-boxes and all the working parts. It is extended rearward and made to support a tank and provisions for carrying fuel, serving in good part the duties of what is ordinarily a separate carriage known as a "tender." A portion of the water-supply is, however, carried in tanks on each side of the boiler. The part M, which may, for convenience, be styled the "tender," carries all the fuel and a portion of the water. Other and ordinarily the main portions of the water are carried in tanks O O extending along on each side of the boiler. The pipes which connect the several tanks with the feeding devices and with each other are controlled by cocks, so that the water may be used out of either at pleasure. By using the water from the tender-tank M and allowing it to remain in the side tanks O O the adhesion of the driving-wheels is retained at its maximum for the longest possible time in a run.

Those parts to which I do not refer, it will be understood, may be constructed in any ordinary or suitable manner.

There are three pairs of driving-wheels, O C C. The central and rearmost are flanged and form the guiding-wheel base. The foremost are without flanges, and are of sufficient width to allow for all curves and switches. At each end of the entire machine is a Bissell truck, or what is sometimes known as a "half truck;" in other words, there is at each end a single pair of small bearing-wheels with flanges, supported in a frame with a radius-bar pivoted to the main framing, and with liberty to move to one side and the other, supporting the weight on swinging links which tend always to keep the truck directly central. A single pair of equalizing-levers, D D, is employed at the forward end of the structure. These extend fore and aft, and are mounted, one on each side, a little within and above the frame-work B. The rear end of each lever D bears on and is firmly confined to the for-

ward end of the spring of the corresponding forward driver. The forward end of each of these levers D D bears on a pin, E, which, playing vertically in the locomotive, bears on a cross-piece below, which I will term a swing-beam. The levers D D distribute the shocks and equalize them between the front truck and the front pair of drivers C. Another pair, G G, of equalizing-levers is employed at the sides of the fire-box. They are mounted just over the framing B and equalize between the springs of the middle and rear pairs of driving-wheels. A cross equalizing-lever, H, is mounted under the foot-board and connects the rear ends of the springs of the after or hindmost drivers. Its center supports the forward end of a fore-and-aft lever, I, which latter extends along the central line of the structure, and bears at its rear end on a swing-beam, J, in the rear truck W. The lever I is formed double or of two parallel pieces, but the parts are rigidly connected, so that both serve as one. The cross-lever H is also double. The effect of the system of levers G H I is to equalize between the middle and the hindmost pair of driving-wheels and between both and the rear half-truck. The connection of the front and of the longitudinal central equalizer I to the cross-equalizer H is made by the aid of a screw, L, with a nut, l, by adjusting which with a jam-nut, also, if preferred, I can change the elevation of the parts at will. This is particularly important in getting the levers in their proper nearly horizontal positions when the locomotive is new or has just received new springs, and may be important in compensating from time to time for the partial failure of springs. The front levers D D, though converging inward, as shown, have their bearings sufficiently wide apart to support the structure efficiently against all lateral inclinations at the forward end; but the cross-equalizer H and central lever I at the rear give the effect of a complete central bearing to the support at the rear, and the structure is thus enabled to tilt freely at the rear as called for at the front and accommodate itself to all twisting of the track. P is a casting rectangular in its horizontal section and free to slide up and down between correspondingly-shaped guides B' firmly bolted to the main frame B and forming a rigid part of the locomotive.

It slides up and down, as required, but is so held between the guides B' that it cannot twist around. The upper portion of the casting P is made with a liberal opening through its front and rear, as shown, and the draw-bar Q stands in the opening thus provided and plays back and forward, as required, by the strain thereon and the action of its spring not represented. The central casting P receives the load by means of the equalizing-lever I, and is supported upon the swing-beam J of the rear truck by a circular bearing, which allows of a swiveling around of the truck while supporting it firmly in all directions horizontally, as will be readily understood. (See Figs. 5 and 6.) I usually employ a layer of rubber interposing between, surmounted by a thin plate of iron. The thin iron serves as a friction-plate for the swiveling of the truck while the rubber softens the shocks.

I claim as my improvements in locomotives having a stiff frame-work extended and serving in the place of a tender-frame—

1. The central block P rising and sinking freely, as required, but restrained from turning within the guides B' and transmitting the weight from the equalizing system of levers to the swiveling central bearing of the swing-beam of a truck, as herein specified.

2. The opening through such central block P with the draw-bar Q, arranged to play freely therein, as specified.

3. The adjusting-screw L, in combination with the equalizing-levers G H I and arranged to serve therein, as and for the purposes herein specified.

4. The obliquely-mounted equalizing-levers D D serving between the springs of the drivers and the swing-beam in the truck, as and for the purposes specified.

5. The arrangement of the side tanks O O and the rear tank M relatively to each other, and to the rigid framing B and boiler A of the locomotive, and adapted to serve together, as and for the purposes herein specified.

In testimony whereof I have hereunto set my name in presence of two subscribing witnesses.

WM. S. HUDSON.

Witnesses:

ARNOLD HOERMANN,  
C. C. LIVINGS.