



(51) International Patent Classification:

G01B 11/25 (2006.01) G06T 7/60 (2006.01)
G06T 1/00 (2006.01) H04N 5/225 (2006.01)

(21) International Application Number:

PCT/US2017/043174

(22) International Filing Date:

20 July 2017 (20.07.2017)

(25) Filing Language:

English

(26) Publication Language:

English

(30) Priority Data:

62/364,320 20 July 2016 (20.07.2016) US
62/511,964 27 May 2017 (27.05.2017) US
15/655,656 20 July 2017 (20.07.2017) US

(71) Applicant: MURA INC. [US/US]; 4030 Moorpark Avenue, #126, San Jose, California 95117 (US).

(72) Inventors: JIANG, Jun; 2454 Michele Jean Way, Santa Clara, California 95050 (US). MENG, Lingfei; 3023 Kaiser Drive Unit F, Santa Clara, California 95051 (US).

(74) Agent: MARTINEZ-LEMKE, Sheila et al.; Weaver Austin Villeneuve & Sampson LLP, P.O.Box 70250, Oakland, California 94612-0250 (US).

(81) Designated States (unless otherwise indicated, for every kind of national protection available): AE, AG, AL, AM, AO, AT, AU, AZ, BA, BB, BG, BH, BN, BR, BW, BY, BZ, CA, CH, CL, CN, CO, CR, CU, CZ, DE, DJ, DK, DM, DO, DZ, EC, EE, EG, ES, FI, GB, GD, GE, GH, GM, GT, HN,

HR, HU, ID, IL, IN, IR, IS, JO, JP, KE, KG, KH, KN, KP, KR, KW, KZ, LA, LC, LK, LR, LS, LU, LY, MA, MD, ME, MG, MK, MN, MW, MX, MY, MZ, NA, NG, NI, NO, NZ, OM, PA, PE, PG, PH, PL, PT, QA, RO, RS, RU, RW, SA, SC, SD, SE, SG, SK, SL, SM, ST, SV, SY, TH, TJ, TM, TN, TR, TT, TZ, UA, UG, US, UZ, VC, VN, ZA, ZM, ZW.

(84) Designated States (unless otherwise indicated, for every kind of regional protection available):

ARIPO (BW, GH, GM, KE, LR, LS, MW, MZ, NA, RW, SD, SL, ST, SZ, TZ, UG, ZM, ZW), Eurasian (AM, AZ, BY, KG, KZ, RU, TJ, TM), European (AL, AT, BE, BG, CH, CY, CZ, DE, DK, EE, ES, FI, FR, GB, GR, HR, HU, IE, IS, IT, LT, LU, LV, MC, MK, MT, NL, NO, PL, PT, RO, RS, SE, SI, SK, SM, TR), OAPI (BF, BJ, CF, CG, CI, CM, GA, GN, GQ, GW, KM, ML, MR, NE, SN, TD, TG).

Published:

- with international search report (Art. 21(3))
- before the expiration of the time limit for amending the claims and to be republished in the event of receipt of amendments (Rule 48.2(h))

(54) Title: SYSTEMS AND METHODS FOR 3D SURFACE MEASUREMENTS

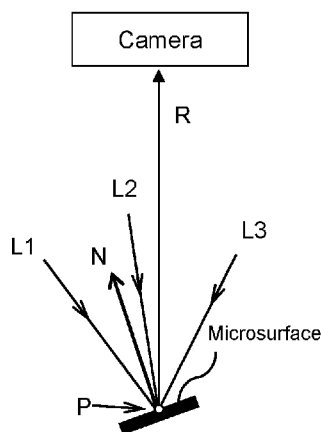

FIG. 1A

(57) Abstract: Certain embodiments are directed to 3D surface measurement systems and methods configured to direct engineered illumination of beams in one or more ray bundles to N illumination directions incident a sample surface. The systems and methods can measure a map of surface normals, a depth map, and a map of surface properties using intensity images captured while the engineered illumination is directed to the sample surface.



SYSTEMS AND METHODS FOR 3D SURFACE MEASUREMENTS

CROSS-REFERENCES TO RELATED APPLICATIONS

[0001] This application claims priority to U.S. Application No. 15/655,656 titled
5 “Systems and Methods for 3D Surface Measurements” and filed on July 20, 2017 and
to U.S. Provisional Patent Application No. 62/364,320, titled “Systems and Methods
for 3D Surface Microgeometry and Reflectance Properties Measurement” and filed on
July 20, 2016 and to U.S. Provisional Patent Application No. 62,511,964, titled
“Systems and Methods for 3D Surface Microgeometry and Reflectance Properties
10 Measurement” and filed on May 27, 2017, each of which is hereby incorporated by
reference in its entirety and for all purposes.

FIELD

[0002] Certain embodiments described herein are generally related to measurement
systems, and more particularly, to methods and systems for 3D surface measurements
15 (3DSM methods and systems) used to measure surface microgeometry and/or surface
properties as may be implemented, for example, in manufacturing for defect detection
and quality control, as well as in other applications such as computer graphics.

BACKGROUND

[0003] The measurement of the 3D surface microgeometry (also referred to as
20 topography) with high depth resolution has proven to be very difficult and is the focus
of active research in the fields of 3D metrology and computer vision. In the field of
3D metrology, a non-contact optical approach is of particular interest driven by
customer requirements for greater simplicity and higher speed. Some conventional
techniques that can be used to measure surface depth with nanometer to micron-scale
25 depth resolution include white light interferometer, confocal microscope, and focus
variation. Conventional instruments that use these techniques generally have,
however, a narrow field-of-view, short working distance, and shallow depth-of-field
since they use high magnification microscope objectives. These conventional
instruments also tend to be very expensive due to their use of sophisticated optical and
30 mechanical components. Moreover, the devices based on interferometry are
commonly sensitive to the ambient environment, such as vibration. Also, most of
these techniques are designed to take surface topography measurements, and are

unable to capture reflectance properties such as diffuse reflection and specular reflection. An example of a white light interferometer can be found in De Groot, P., “Principles of interference microscopy for the measurement of surface topography,” *Advances in Optics and Photonics*, vol.7, no.1, pp.1-65 (2015), which is hereby
5 incorporated by reference for this example. An example of focus variation device can be found in Matilla, A., et al., Three-dimensional measurements with a novel technique combination of confocal and focus variation with a simultaneous scan,” *Proc. SPIE*, pp.98900B–11, (2016), which is hereby incorporated by reference for this example.

10 **[0004]** In the field of computer vision, some research has been done on 3D surface measurement with somewhat simpler setups. The photometric stereo technique is a method to reconstruct surface normal and depth by capturing multiple images under different lighting directions, but this method assumes the scene to be Lambertian (diffusive). An example of a method to reconstruct surface normal and depth by
15 capturing multiple images under different lighting directions can be found in Basri, D., et al., “Photometric stereo with general, unknown lighting,” *International Journal of Computer Vision*, vol. 72, no.3, pp.239–257 (2007), which is hereby incorporated by reference for this example. In real world most of the objects are not purely diffusive, and can be specular or hybrid. Recently new techniques have been explored
20 to address objects that are not diffusive. Some methods have been proposed to address microgeometry measurement on specular surfaces. Examples of such methods can be found in Chen, T., et al, Mesostructure from specularity,” *Proc. CVPR*, pp.1825–1832 (2006) and Francken, Y., et al., “High quality mesostructure acquisition using specularities,” in *Proc. CVPR*, p. 1-7 (2007), which are hereby incorporated by
25 reference for these examples. These proposed methods either use hand-moved point light source or structured illumination to reconstruct depth from specularity, but their approaches can only capture images with limited number of lighting directions and therefore may result in insufficient samplings of the reflectance field. In another
30 example, an object is pressed into an elastomer skin to remove the specular reflection of the object, and a photometric stereo technique is used to estimate the surface normal based on reflection from the covered skin. An example can be found in U.S. Patent Publication 20130033595, titled “HIGH-RESOLUTION SURFACE MEASUREMENT SYSTEMS AND METHODS,” by Adelson, H., and Johnson, Micah K., which is hereby incorporated by reference for this example. However,

when using this approach, the true reflection from the sampled object is blocked by the elastomer skin, and information about the color or other reflectance properties is lost.

[0005] In the field of computer graphics, some research has been done on the simultaneous acquisition of surface geometry and reflectance properties for computer graphics rendering. For example, a photometric stereo technique for objects with spatially varying bidirectional reflectance distribution function (BRDF) can be found in Goldman, D.B., et al. "Shape and spatially-varying BRDFs from photometric stereo," IEEE Trans. PAMI, vol. 32, no.6, pp.1060–1071 (2010), which is hereby incorporated by reference in its entirety. In this example, multiple images are captured under different lighting directions, and then the shape and reflectance parameters are reconstructed from a BRDF model for rendering. However, this method requires that the camera and illumination be at far distance from the sample in order to fulfill the orthographic assumption, and the method is unable to capture detailed microgeometry of the surface due to limited number of illumination directions. In addition, a reflectometry technique has been proposed for surface normal, height, diffuse and specular reflectance parameters measurement, but this method requires a linear light source be moved across the object surface. An example of such a reflectometry system can be found in U.S. Patent No. 6,919, 962, titled "Reflectometry apparatus and method," which is hereby incorporated by reference for this example. A specular object scanner for measuring reflectance properties of objects has also been proposed, but this scanner requires an arc-shaped light source to be rotated around the object. An example of such a specular object scanner can be found in U.S. Patent Application No. 14/212,751 titled "Specular object scanner for measuring reflectance properties of objects," which is hereby incorporated by reference for this example. In addition, a 12-light hemispherical dome for capturing detailed microgeometry of skin texture has been developed, which may improve the realism of facial synthesis. An example of such a system is found in Graham, P., et al., "Measurement-based synthesis of facial microgeometry," in Computer Graphics Forum, vol.32, no.2, pt. 3. Wiley Online Library, pp.335–344 (2013), which is hereby incorporated by reference for this example. However, in this example, the 12-light hemispherical dome has limited angular samplings above the surface, and may not work well for specular objects that are smoother. To acquire much denser samplings, the example discusses using a light

stage, but the light stage is large and some of the lights may be occluded by the camera.

[0006] In these conventional techniques, the camera and multiple illuminations are placed at a far distance in order to fulfill the orthographic assumptions. Such a setup typically introduces a large form factor, and some of the illuminations may be occluded by the camera. Because the camera is not able to capture images of the surface closely, it is difficult to achieve micron-level depth resolution and accuracy. These conventional techniques use a limited number of extended light sources, and are typically arranged with large angular sampling steps due to the constraints in their physical dimensions. This may result in insufficient samplings of the reflectance field, and bias the surface normal estimation for specular surfaces that are relatively smoother. Moreover, typically some extended illuminations were placed at oblique angles introducing severe shadow effects. Most of these conventional techniques are unable to measure the reflectance properties of the surface.

SUMMARY

[0007] Certain embodiments pertain to methods and systems for 3D surface measurements.

[0008] Certain embodiments are directed to a 3D surface measurement system comprising an engineered illumination system configured to provide at least one ray bundle to N illumination directions incident a surface of a sample being imaged. Each ray bundle comprises illumination beams of various intensities. The 3D surface measurement system further comprises a camera with an imaging lens and at least one sensor configured to capture intensity images at the N illumination directions based on light received from the illuminated sample. In addition, the 3D surface measurement system comprises a controller configured to execute instructions to determine a sensor response at each sensor pixel from the intensity images at the N illumination directions, match the sensor response at each sensor pixel to one of a plurality of predetermined sensor responses to determine a surface normal at each sensor pixel, and construct a map of surface normals of the surface by combining the determined surface normal of all the sensor pixels of the at least one sensor.

[0009] Certain embodiments are directed to a 3D surface measurement method that receives a plurality of intensity images of a sample in a signal from at least one sensor

of a camera. The plurality of intensity images have been captured at a plurality of exposure times at each illumination direction of N illumination directions of one or more ray bundles, wherein each ray bundle comprises illumination beams of various intensities. The method also determines a sensor response at each sensor pixel from the intensity images at the N illumination directions. In addition, the method matches a sensor response at each sensor pixel to one of a plurality of predetermined sensor responses to determine a surface normal at each sensor pixel and constructs a map of surface normals by combining the determined surface normal of all the sensor pixels of the at least one sensors.

10 **[0010]** Certain embodiments are directed to a 3D surface measurement method that engineers at least one ray bundle to N illumination directions incident a surface a sample being imaged, each ray bundle comprising illumination beams of various intensities. The method also captures, using at least one sensor of a camera, wherein the intensity images are captured at a plurality of exposure times at each illumination direction based on light from the illuminated sample. In addition, the method communicates the intensity images to one or more processors. The one or more processors determine a sensor response at each sensor pixel from the intensity images at the N illumination directions, match a sensor response at each sensor pixel to one of a plurality of predetermined sensor responses to determine a surface normal at each sensor pixel, and construct a map of surface normals by combining the determined surface normal of all the sensor pixels of the at least one sensor.

25 **[0011]** Certain embodiments are directed to a 3D surface measurement method for calibrating a 3D surface measurement system. The method comprises engineering at least one ray bundle to N illumination directions incident a surface of a mirror or a chrome sphere, each ray bundle comprising illumination beams of various intensities. The method further comprises capturing, using at least one sensor of a camera, intensity images at each illumination direction based on light reflected from the mirror or the chrome sphere. The method further comprises determining a calibration offset and the N illumination directions based on the intensity images.

30 **[0012]** These and other features are described in more detail below with reference to the associated drawings.

BRIEF DESCRIPTION OF THE DRAWINGS

[0013] **FIG. 1A** is a simplified schematic drawing depicting a single microsurface of a sample having a surface normal N , according to one implementation

[0014] **FIG. 1B** shows a schematic illustration of a series of eighty-one (81) predetermined sensor responses corresponding to eighty-one (81) surface normal orientations of a 3DSM system, according to an implementation.

[0015] **FIG. 2** is a simplified block diagram depicting components of a 3DSM system, according to various implementations.

[0016] **FIG. 3A** is a graph with a first transmission profile of a first diffuser and a second transmission profile of a second diffuser, both profiles having distributions that are Gaussian or Gaussian-like, according to embodiments.

[0017] **FIG. 3B** is a graph with a linear gradient profile, according to an embodiment.

[0018] **FIG. 3C** is a graph of a random distribution profile, according to an embodiment.

[0019] **FIG. 4** is a schematic drawing depicting a side view of components of a 3DSM system during a data acquisition phase of a 3DSM method, according to an embodiment.

[0020] **FIG. 5** is a schematic drawing depicting a side view of components of a 3DSM system during a data acquisition phase of a 3DSM method, according to an embodiment.

[0021] **FIGS. 6A-6C** are schematic diagrams depicting three operations of a data acquisition phase of a 3DSM method performed by a 3DSM system, according to various embodiments.

[0022] **FIG. 6D** is a schematic diagram depicting a general approach taken during an analysis phase performed by the 3DSM system of **FIGS. 6A-6C**, according to various embodiments.

[0023] **FIG. 7** is a schematic drawing depicting a 3DSM system configured to generate engineered illumination using collimated illumination and a diffuser, according to an embodiment.

- [0024] FIG. 8 is a sensor response image captured without engineered illumination.
- [0025] FIG. 9 is a sensor response image captured with engineered illumination provided by the 3DSM system shown in FIG. 7, according to an embodiment.
- [0026] FIG. 10A is a schematic drawing depicting components of a 3DSM system including a combination filter, according to an embodiment.
- [0027] FIG. 10B is an illustration of a transmittance profile of a combination filter, according to an implementation.
- [0028] FIG. 10C is an illustration of a transmittance profile of a combination filter, according to an implementation.
- 10 [0029] FIG. 10D is an illustration of a transmittance profile of a combination filter with a linear gradient, according to an implementation.
- [0030] FIGS. 11A-11B are schematic diagrams depicting three operations of a data acquisition phase of a 3DSM method performed by a 3DSM system configured for engineered illumination direction manipulation, according to an embodiment.
- 15 [0031] FIG. 12 is a schematic diagram depicting an operation of a data acquisition phase of a 3DSM method performed by a 3DSM system, according to an embodiment.
- [0032] FIG. 13 is a schematic drawing depicting components of a 3DSM system including additional illumination devices, according to an embodiment.
- 20 [0033] FIGS. 14A-14B are schematic diagrams depicting components of a 3DSM system configured for illumination direction manipulation, according to an embodiment.
- [0034] FIGS. 15A-15C are schematic diagrams depicting a calibration process using a mirror as a reference object performed by a 3DSM system, according to an embodiment.
- 25 [0035] FIGS. 16A-16B are illustrations of an offset of incident beams resulting from the calibration process depicted in FIGS. 15A-15C, according to an implementation.

- [0036] FIGS. 17A and 17B are illustrations depicting a system alignment process using the results of the calibration process depicted in FIGS. 15A-15C, according to an implementation.
- [0037] FIGS. 18A-18C are schematic diagrams depicting three operations of a system calibration process performed by a 3DSM system including a chromosome array, according to an embodiment.
- [0038] FIGS. 19A-19B are images of a single chromosome of a chromosome array illuminated at two different illumination directions during a calibration process, according to an embodiment.
- [0039] FIGS. 20A and 20B are illustrations of the calibrated zenith angles and azimuth angles for 169 different illumination directions using the calibration process depicted in FIGS 17A-17C, according to an implementation.
- [0040] FIGS. 21A-21C is a schematic diagram depicting a 3DSM system implementing a calibration process using a combination of a mirror and a single chromosome, in accordance with an embodiment.
- [0041] FIG. 22 depicts a series of pre-determined sensor responses of a single sensor pixel, according to an embodiment.
- [0042] FIG. 23 is a schematic representation depicting the operation of matching a measured sensor response for a single sensor pixel corresponding to a surface pixel to one of a series of pre-determined sensor responses, according to an embodiment.
- [0043] FIG. 24A is a photograph of a leather sample showing an area being analyzed by a 3DSM system, according to an embodiment.
- [0044] FIG. 24B is an illustration of a measured depth map of the area of the leather surface of FIG. 24A as measured by the 3DSM system.
- [0045] FIG. 24C is an illustration of a measured surface normal map of the area of the leather surface of FIG. 24A as measured by the 3DSM system.
- [0046] FIG. 24D is an illustration of a measured diffuse map of the area of the leather surface of FIG. 24A as measured by the 3DSM system.
- [0047] FIG. 24E is an illustration of a specular map of the area of the leather surface of FIG. 24A as measured the 3DSM system.

[0048] FIG. 24F is an illustration of a surface roughness map of the area of the leather surface of FIG. 24A as measured the 3DSM system.

[0049] FIG. 25A is a photograph of a coin.

[0050] FIG. 25B is a 3D rendering using measured depth map of the coin shown in
5 FIG. 25A, according to an embodiment.

[0051] FIG. 25C is graph having a measured depth curve measured along the black line of the coin as shown in FIG. 25A, according to an embodiment.

[0052] FIGS. 26A-26D are renderings based on microgeometry and reflectance properties measured by an 3DSM system, according to an implementation.

10 [0053] FIGS. 27A-27C are schematic diagrams depicting operations of a data acquisition phase implemented by a 3DSM system configured to control wavelength and polarization of the engineered illumination, according to an embodiment.

[0054] FIGS. 28A-28C are schematic diagrams depicting three operations of a data acquisition phase implemented by a 3DSM system that controls wavelength and
15 polarization of the reflected light from the surface of the sample, in accordance with an embodiment.

[0055] FIGS. 29A-29C are schematic diagrams depicting three operations of a data acquisition phase implemented by a 3DSM system that controls wavelength and polarization of both the engineered illumination and the reflected light from the
20 surface of the sample, in accordance with an embodiment.

[0056] FIG. 30 is a schematic diagram illustrating components of a 3DSM system configured to control wavelength and polarization of both the engineered illumination and the reflected light from the surface of the sample, in accordance with an embodiment.

25 [0057] FIGS. 31A-31C are schematic diagrams depicting operations of a data acquisition phase implemented by a 3DSM system configured to control the motion of the sample surface, according to an embodiment.

[0058] FIGS. 32A-32C are schematic diagrams depicting operations of a data acquisition phase implemented by a 3DSM system configured to control the motion of
30 the engineered illumination and the camera, according to an embodiment.

[0059] FIG. 33 is a schematic diagram depicting operations of a data acquisition phase and an analysis phase of a 3DRM method that obtains surface emissivity properties using a 3DSM system configured to control the motion of the sample surface, according to an embodiment.

5 [0060] FIG. 34 is a schematic diagram depicting operations of a data acquisition phase and an analysis phase of a 3DRM method that obtains surface emissivity properties using a 3DSM system configured to control the motion of the engineered illumination and the camera, according to an embodiment.

10 [0061] FIG. 35 is a schematic diagram depicting operations of a data acquisition phase and an analysis phase of a 3DRM method that obtains surface emissivity properties using a 3DSM system configured to control the wavelength and/or the polarization of the emitted light from the sample surface, according to an embodiment.

15 [0062] FIG. 36 is a schematic diagram depicting operations of a data acquisition phase and an analysis phase of a 3DRM method that obtains surface translucency properties using a 3DSM system configured to control the motion of a translucent sample, according to an embodiment.

20 [0063] FIG. 37 is a schematic diagram depicting operations of a data acquisition phase and an analysis phase of a 3DRM method that obtains surface translucency properties using a 3DSM system configured to control the motion of a backlight, according to an embodiment.

25 [0064] FIG. 38 is a schematic diagram depicting operations of a data acquisition phase and an analysis phase of a 3DRM method that obtains surface translucency properties using a 3DSM system configured to control the engineered illumination and the camera, according to an embodiment.

30 [0065] FIG. 39 is a schematic diagram depicting operations of a data acquisition phase and an analysis phase of a 3DRM method that obtains surface translucency properties using a 3DSM system configured to control the wavelength and/or polarization of both the backlight and light transmitted from the surface of the sample, according to an embodiment.

- [0066] FIG. 40 is a schematic diagram depicting the 3DSM system of FIGS. 11A-B and FIG. 12 that is configured to switch the engineered illumination to an off state, according to an implementation.
- [0067] FIG. 41 is a schematic drawing depicting a data acquisition operation of a 3DSM system, according to an embodiment.
- [0068] FIG. 42 is a flowchart of operations of a 3DSM method, according to various implementations.
- [0069] FIG. 43 is a flowchart depicting sub-operations of an operation of the 3DSM method of FIG. 42.
- [0070] FIG. 44 is a flowchart depicting sub-operations of an operation of the 3DSM method of FIG. 42.
- [0071] FIG. 45 is a block diagram depicting inputs and outputs of the rendering operation, according to an embodiment.
- [0072] FIG. 46A is an illustration of diffuse reflection properties of a synthetic leather surface as measured by a 3DSM system, according to an embodiment.
- [0073] FIG. 46B is an illustration of specular reflection properties of the synthetic leather surface as measured by the 3DSM system of FIG. 46A, according to an embodiment.
- [0074] FIG. 46C is an illustration of glossiness properties of the synthetic leather surface as measured by the 3DSM system of FIG. 46A, according to an embodiment.
- [0075] FIG. 46D is an illustration of a measured base color that describes the combined color appearance of both diffuse reflection and specular reflection of the synthetic leather surface as measured by the 3DSM system of FIG. 46A, according to an embodiment.
- [0076] FIG. 46E is an illustration of a measured metallic map that describes the dielectric and metallic properties of the synthetic leather surface as measured by the 3DSM system of FIG. 46A, according to an embodiment.
- [0077] FIG. 46F is an illustration of roughness properties measured by the 3DSM system of FIG. 46A, according to an embodiment.

- [0078] FIG. 46G is an illustration of a normal map of the synthetic leather surface as measured by the 3DSM system of FIG. 46A, according to an embodiment.
- [0079] FIG. 46H is an illustration of measured depth map of the synthetic leather surface as measured by the 3DSM system of FIG. 46A, according to an embodiment.
- 5 [0080] FIG. 46I is a physically-based rendering of the synthetic leather surface as measured by the 3DSM system of FIG. 46A, according to an embodiment.
- [0081] FIG. 47 is a block diagram depicting operations of a 3DSM method that includes a defect detection process, according to an embodiment.
- [0082] FIG. 48 is a block diagram depicting operations of a 3DSM method that
10 includes a defect detection process, according to an embodiment.
- [0083] FIG. 49A is an illustration of specular reflection properties of an LCD panel that is contaminated with dirt and fiber measured by a 3DSM system configured for defect detection, according to an embodiment.
- [0084] FIG. 49B is an illustration of diffuse reflection properties of the LCD panel
15 with dirt and fiber as measured by the 3DSM system of FIG. 49A, according to an embodiment.
- [0085] FIG. 49C is an illustration of surface roughness properties of the LCD panel with dirt and fiber as measured by the 3DSM system of FIG. 49A, according to an embodiment.
- 20 [0086] FIG. 49D is an illustration of a measured normal map of the LCD panel with dirt and fiber as measured by the 3DSM system of FIG. 49A, according to an embodiment.
- [0087] FIG. 49E is an illustration of a measured depth map of the LCD panel with dirt and fiber as measured by the 3DSM system of FIG. 49A, according to an
25 embodiment.
- [0088] FIG. 49F is an illustration of surface defect visualization operation using the measured parameters illustrated in FIGS. 49A-49E using a 3DSM method including defect detection implemented by the 3DSM system, according to an embodiment.

[0089] FIG. 50A is an illustration of measured specular reflection properties of an LCD panel with scratches and pits as measured by a 3DSM system configured for defect detection, according to an embodiment.

5 [0090] FIG. 50B is an illustration of measured diffuse reflection properties of an LCD panel with scratches and pits as measured by the 3DSM system of FIG. 50A, according to an embodiment.

[0091] FIG. 50C is an illustration of measured surface roughness properties of an LCD panel with scratches and pits as measured by the 3DSM system of FIG. 50A, according to an embodiment.

10 [0092] FIG. 50D is an illustration of measured normal map of an LCD panel with scratches and pits as measured by the 3DSM system of FIG. 50A, according to an embodiment.

[0093] FIG. 50E is an illustration of measured depth map of the LCD panel with scratches and pits as measured by the 3DSM system of FIG. 50A, according to an
15 embodiment.

[0094] FIG. 50F is an illustration of surface defect detection using parameters measured by the 3DSM system of FIG. 50A, according to an embodiment.

[0095] FIG. 51 is an illustration depicting a measured brightness map of an LCD panel with a white spot as measured by a surface defect detection process in a 3DSM
20 method implemented by a 3DSM system, according to an embodiment.

[0096] FIG. 52 is an illustration depicting a measured uniformity map of the LCD panel with non-uniformity as measured by a surface defect detection process in a 3DSM method implemented by the 3DSM system described in FIG. 51, according to an embodiment.

25

DETAILED DESCRIPTION

[0097] The following description is directed to certain implementations for the purposes of describing various aspects of this disclosure. However, a person having ordinary skill in the art will readily recognize that the teachings herein can be applied in a multitude of different ways. Thus, the teachings are not intended to be limited to the implementations depicted solely in the Figures, but instead have wide applicability as will be readily apparent to one having ordinary skill in the art.

[0098] Embodiments pertain to methods and systems for 3D surface measurements (3DSM methods and systems) including measurements of microgeometry and surface properties such as reflectance properties, emissivity properties, translucency properties, etc. The 3DSM systems implement methods that can be used to simultaneously acquire surface geometry and properties. In various embodiments, a 3DSM system comprises an engineered illumination system that generates and manipulates incident directions of engineered illumination to different points along a surface of a sample to N different illumination directions. The engineered illumination has a known distribution such as a Gaussian distribution, a pattern, etc. During data acquisition, light from the surface is captured by one or more sensors of a digital camera for the N different illumination directions. The 3DSM system captures a measured sensor response for each sensor pixel for the N different illumination directions. The 3DSM system determines a surface normal for each of the sensor pixels, for example, by matching the measured sensor response to the best fitting of a group of pre-determined sensor responses. Each pre-determined sensor response corresponds to a surface normal. The pre-determined sensor responses for different surface normals can be calculated based on the known distribution of the engineered illumination at different illumination directions. During an analysis phase, the 3DSM system determines a surface normal at each point of the surface by matching the measured sensor response to a pre-determined sensor response. The 3DSM system can estimate a depth map from the surface normals at the different points across the surface. The 3DSM system can also use the map of surface normals to determine surface properties such as reflectance properties e.g. diffuse albedo, specular albedo and roughness, estimated, for example, based on a BRDF model.

I. Introduction to 3DSM systems and methods

[0099] Most real-world surfaces are not flat, and can be approximated as a series of flat microspheres facing various directions. Each of these flat microspheres has a surface normal vector (also referred to herein as a “surface normal”). A two-dimensional (2D) grid of surface normals at points across a three-dimensional surface corresponds to the contours of the surface. A depth map (topographical) of the surface and various surface properties such as, e.g., reflective properties, can be determined from the 2D grid of surface normals. Examples of techniques that can be used to determine a depth map and surface properties from surface normals can be found in U.S. Patent Publication 20130033595, titled “HIGH-RESOLUTION SURFACE MEASUREMENT SYSTEMS AND METHODS,” by Adelson, H., and in Johnson, M. K., et al., “Shape and spatially-varying BRDFs from photometric stereo,” IEEE Trans. PAMI, vol. 32, no.6, pp.1060–1071 (2010).

[0100] In certain implementations, a 3DSM system comprises an engineered illumination system configured to direct a ray bundle having illumination beams of varying intensities to points (also referred to herein as “pixels”) along the surface of a sample. The illumination beams of the ray bundle have a known engineered intensity distribution. In many cases, the engineered illumination system includes a motion control device configured to rotate and/or translate one or more system components to cause the rotation of the ray bundle relative to the sample. The ray bundle is rotated in two orthogonal directions to direct the ray bundle to different illumination directions incident the sample while a camera measures the intensity distribution of light propagated from the illuminated sample. The intensity distribution measured during an exposure time is referred to herein as an “intensity image” or simply as an “image.” The intensity images can be used to generate the 2D grid of surface normals of the sample.

[0101] In one implementation, either the sample is manipulated (rotated/translated) or the engineered illumination and camera are manipulated together to scan the engineered illumination over the sample during data acquisition. The 3DSM system analyzes the captured images to measure maps of surface normals, depths, and surface properties the sample using the images captured. During data acquisition of a large area sample, the engineered illumination is scanned over a region of the large area sample and then scanned over another region, and so on, until the entire sample is

scanned. The 3DSM system can stitch together the measured maps of the surface normals, depths, and surface properties for the different regions of a large area sample to generate maps of the entire surface. This approach may have one or more technical advantages. One technical advantage may be the ability to measure over a large area surface. Another technical advantage is that the measured maps of the surface normals, depths, and surface properties for the different regions of a large area sample can be stitched together, which provides for high spatial resolution in the measured maps of the entire surface. Another technical advantage is that the 3DSM system can more precisely control collimated illumination to a smaller region of the sample than would be possible with a large area surface.

[0102] FIG. 1A is a simplified schematic drawing of a single microsurface of a sample having a surface normal N , according to an embodiment. In this simplified scenario, a ray bundle of three (3) beams $L1$, $L2$, and $L3$ of different intensities is shown incident a surface point P of the microsurface. As shown, only the $L1$ beam is reflected (shown as a reflected beam R) back to a camera and a sensor of the camera measures an intensity value of the $L1$ beam. The $L2$ and $L3$ beams are not reflected back to the camera. Since the three (3) beams $L1$, $L2$, and $L3$ are engineered with a particular known intensity distribution for various output angles, the sensor reading corresponds to the known intensity value of the $L1$ beam. In this way, the 3DSM system can use the sensor reading to identify the $L1$ beam as reflected from the microsurface. The angle of the illumination beam $L1$ is also known based on the intensity distribution and the configuration of any optical elements propagating illumination to the surface. The 3DSM system can determine the surface normal of the microsurface based on the known angle of the identified illumination beam $L1$ and the orientation of the sensor.

[0103] In certain scenarios, the engineered illumination comprises a ray bundle of illumination beams where some beams have the same or substantially similar intensities. In addition or alternatively, components of the system may have various transmission properties and sensor may have limited dynamic range. In these cases, a sensor reading of a particular intensity value may not be unique to a single illumination beam and could correspond to multiple beams having similar output power. For example, if beam $L1$ and beam $L3$ shown in FIG. 1A had the same power, the sensor reading based on receiving beam $L1$ would correspond to both of the

illumination beams $L1$ and $L3$. In order to determine the beam being reflected from the microsurface and estimate the surface normal, certain 3DSM systems described herein take sensor readings at different illumination directions of the ray bundle at each surface point. In some cases, the 3DSM systems include a motion control device
5 that rotates one or more system components to rotate the ray bundle together in two orthogonal directions to direct the ray bundle to a sequence of N illumination directions. For a particular 3DSM system, each surface normal has a unique sensor response for N illumination directions based on rotating the ray bundle in two orthogonal directions. Each measured sensor response is a pattern of intensity values
10 measured at a sensor pixel for the different illumination directions. For example, a sensor response pattern may have four hundred (400) intensity values associated with four hundred (400) illumination directions based on 20 rotational angles along an x-direction and 20 rotational angles along a y-direction orthogonal to the x-direction. In various implementations, the 3DSM system compares the measured sensor response
15 to predetermined sensor responses. The 3DSM system determines a predetermined sensor response that matches most closely to the measured sensor response to estimate the surface normal at each pixel.

[0104] FIG. 1B shows a schematic illustration of a series of eighty-one (81) predetermined sensor responses corresponding to eighty-one (81) surface normal
20 orientations of a 3DSM system, according to an implementation. In this example, each surface normal has a unique 20 x 20 sensor response pattern of normalized intensity for four hundred (400) rotational positions corresponding to twenty (20) rotational angles along a y-axis (rotation angle Y) and twenty (20) rotational angles along an x-axis (rotation angle X) orthogonal to the y-axis.

25 *II. 3DSM systems*

[0105] FIG. 2 is a simplified block diagram of a 3DSM system 10, according to various implementations. The 3DSM system 10 comprises a controller 20 having a processor 22 and a memory 24 in electrical communication with the processor 22. The processor 22 is configured to control functions of the 3DSM system 10 by executing
30 instructions stored in memory 24. The processor 22 may also retrieve data stored in memory 24 and/or store data to memory 24. The 3DSM system 10 further comprises an engineered illumination system 30 having one or more illumination devices 34, one or more optical elements 36, and a motion control device 32. Each illumination

device **34** includes one or more light sources. The illumination device(s) **34** and optical element(s) **36** are configured to provide engineered illumination to the sample during operation. The 3DSM system **10** further optionally (denoted by the dashed line) comprises a sample platform **40** for receiving the sample and camera(s) **60** with one or more lenses and sensors configured to receive light from the sample during operation and to capture intensity measurements. The motion control device **32** is in communication optionally (denoted by the dashed line) with one or more of the illumination device(s) **34**, the optical element(s) **36**, the camera(s) **60**, and the sample platform **40** in order to control their movement (e.g., translation/rotation) to rotated the engineered illumination relative to the sample to N rotational positions. For example, the motion control device **32** may include a motor coupled to a system component to rotate and/or translate the component so that the engineered illumination is rotated to different rotational positions over a sequence of sample times. The controller **20** is in electrical communication with the illumination device(s) **34** and the camera(s) **60** to send control signals to control functions of these components and to receive data, such as intensity measurements from the camera(s) **60**. For example, the controller **20** may send control signals to the camera(s) **60** and the motion control device **32** to synchronize exposure times of the camera(s) **60** to be at the same time that the motion control device **32** is holding system components in a particular position to provide engineered illumination to a surface at a particular rotational position.

[0106] The 3DSM system **10** optionally (denoted by dashed line) further comprises a communication interface **72** and a display **70** in communication with the communication interface **72**. The controller **20** is configured or configurable to output raw data, processed data such as surface measurements or renderings, and/or other data over the communication interface **72** for display on the display **70**. In another embodiment, the 3DSM system **10** may further comprise one or more additional communication interfaces and/or a computing device in communication with a communication interface. In addition and optionally, the 3DSM system **10** may further comprise an external memory device in communication with a communication interface for storage of data to the external memory device, and/or a communication interface in communication with a user interface for receiving input from an operator of the 3DSM system **10**. The described electrical communication between system components may be able to provide power and/or communicate data. The electrical

communication between system components of various implementations may be in wired form and/or wireless form.

[0107] In various implementations, the 3DSM system includes an engineered illumination system comprising one or more illumination devices, one or more optical elements, and a motion control device. The engineered illumination system is designed to generate and provide for the relative rotation of the engineered illumination in two orthogonal directions with respect to the surface of a sample. Engineered illumination generally refers to one or more ray bundles where each ray bundle is comprised of multiple illumination beams. The illumination beams of each ray bundle are at different angles. The power of the illumination beams at different output angles can be, for example, a linear, a triangular, a curved, or a random distribution. According to one aspect, the power of the illumination beams at different angles is based on a Gaussian distribution or a distribution similar to a Gaussian distribution. In another aspect, the power of the illumination beams at different angles has a linear gradient. In yet another aspect, the power of the illumination beams at different angles is random.

[0108] In various implementations, a 3DSM system implements engineered illumination with illumination beams having power for different output angles in the form of a Gaussian or Gaussian-like distribution. In these cases, the engineered illumination system generally comprises optical elements that include a collimator and a diffuser. The collimator is configured to collimate illumination from one or more light sources. The diffuser is configured to receive collimated illumination and generate the one or more ray bundles. Each ray bundle has an infinite number of illumination beams with output power for different output angles in a Gaussian or Gaussian-like distribution. Examples of suitable diffusers are commercially available. For example, a suitable commercial diffuser is the DG20-1500 manufactured by Thorlabs.

[0109] FIG. 3A is a graph illustrating a first transmission profile 310 through a first diffuser and a second transmission profile 320 through a second diffuser, according to embodiments. These are examples of typical diffuser transmission profiles. Each of the transmission profiles exhibits has a Gaussian-like distribution of output power of illumination beams for different output angles (i.e. angles from the respective diffusers). The transmission profiles 310, 320 are graphs of the distribution of

normalized output power values of the infinite number of illumination beams for different output angles in degrees from the respective diffuser. The transmission profiles **310**, **320** are illustrated to point out three beams along each profile at the output angles of -7 degrees, 0 degrees, and 6 degrees. The first transmission profile

5 **310** has a first beam **336** having a normalized power of about 0.17 at -7 degrees, a second beam **332** having a normalized power of about 0.98 at 0 degrees, and a third beam **338** having a normalized power of about 0.20 at 6 degrees. The second transmission profile **320** has a first beam **330** having a normalized power of about 0.6 at -7 degrees, a second beam **332** having a normalized power of about 0.98 at 0

10 degrees, and a third beam **334** having a normalized power of about 0.67 at 6 degrees. An example of commercially-available diffusers that can provide a non-Gaussian intensity distribution are Engineered DiffusersTM from Thorlabs RPC Photonics.

[0110] In another aspect of the 3DSM system, the engineered illumination includes one or more ray bundles with each ray bundle having illumination beams with power

15 varying based on output angle according to a linear gradient distribution. **FIG. 3B** is a graph illustrating a linear gradient profile **340** of the distribution of illumination beams of a ray bundle for different output angles, according to an embodiment. The linear gradient profile **340** includes normalized power of an infinite number of beams at different output angles. The linear gradient profile **340** has a first beam **342** having

20 a normalized power of 0.5 at -10 degrees, a second beam **344** having a normalized power of about 0.3 at 0 degrees, and a third beam **346** having a normalized intensity of about 0.2 at 10 degrees. In this example, the gradient is decreasing linearly as output angle increases. In other cases, the gradient is increasing linearly.

[0111] In another aspect of the 3DSM system, the engineered illumination includes

25 one or more ray bundles with each ray bundle having illumination beams with power varying based on output angle according to a random distribution. **FIG. 3C** is a graph illustrating a profile **350** of a random distribution of beams, according to an implementation. The profile **350** includes normalized power of the illumination beams at different output angles. The profile **350** has a first beam **352** having a normalized

30 power of about 0.65 at -10 degrees, a second beam **354** having a normalized power of about 0.95 at 0 degrees, and a third beam **356** having a normalized power of about 0.3 at 10 degrees.

[0112] FIG. 4 is a schematic drawing showing a side view of components of a 3DSM system 400 during a time period of operation at which the camera(s) 460 takes multiple exposures at different settings, according to one embodiment. The 3DSM system 400 comprises an engineered illumination system 430, a sample platform 440, and a camera(s) 460. A sample 480 with a surface 482 is shown disposed on the sample platform 440. The 3DSM system 400 includes an x-axis parallel to the surface 480 at the point L , a z-axis normal to the surface 480 at point L , and a y-axis (not shown) orthogonal to the x-axis and the z-axis. At this instant in time, the engineered illumination system 440 is shown providing a ray bundle of six (6) beams of various intensities at different incidence angles to a surface point L at the surface 482 of the sample 480. The ray bundle is directed along a 0 degree illumination direction normal to the surface 482. The rotational position of the ray bundle is at 0 degrees rotation along the x-axis and 0 degrees rotation along the y-axis. It would be understood that although six (6) beams are illustrated for simplicity, an infinite number of beams are incident surface point L . The engineered illumination system 430 comprises a motion control device 432, optical element(s) 436, and illumination device(s) 434. The motion control device 432 is coupled to the optical element(s) 436 and to the camera(s) 460 to be able to translate and/or rotate one or both of these system components to various positions to rotate the ray bundle of six (6) illumination beams to different rotational positions at different sample times during operation. The motion control device 432 is optionally (denoted by dashed line) be coupled to the illumination device(s) 434 to be able to translate and/or rotate the illumination device(s) 434 during operation. For example, the ray bundle may be rotated incrementally along the x-axis and/or along the z-axis. At each rotational position, the one or more sensor(s) of the camera(s) 460 takes intensity measurements (images) of multiple exposures of light propagated from the illuminated sample 480.

[0113] FIG. 5 is a schematic drawing showing a side view of components of a 3DSM system 500 during a time period of operation at which a camera takes multiple exposures, according to one embodiment. The 3DSM system 500 comprises an engineered illumination system 530 and a sample platform 540. A sample 580 with a surface 582 is shown disposed on the sample platform 540. At this instant in time, the engineered illumination system 540 is shown providing three (3) ray bundles including a first ray bundle of three (3) beams $L1$, $L2$, and $L3$ of various intensities at different incidence angles to a surface point L at the surface 582 of the sample 580, a

second ray bundle of three (3) beams $M1$, $M2$, and $M3$ of various intensities at different incidence angles to a surface point M , and a third ray bundle of three (3) beams $N1$, $N2$, and $N3$ of various intensities at different incidence angles to a surface point N . Each of the ray bundles is directed along a 0 degree illumination direction normal to the surface **582**. The 3DSM system **500** includes a local x-axis parallel to the surface **585** at each of points L , M , and N , a local z-axis normal to the surface **582** at each of points L , M , and N , and a local y-axis (not shown) orthogonal to each of x-axis and z-axis at each of points L , M , and N . The engineered illumination system **530** is configured to rotate each of the ray bundles to different rotational positions at different sample times during operation.

[0114] As mentioned above, the 3DSM system of various implementations includes an engineered illumination system configured to generate engineered illumination and manipulate the engineered illumination. The engineered illumination system includes one or more illumination devices, one or more optical elements, and a motion control device. Each illumination device includes one or more light sources. Various forms of light sources can be used, for example, a light emitting diode (LED), a laser, a tungsten, and/or halogen. In various implementations, each light source is a point light source. In another implementation, an illumination source is in the form of a one-dimensional or two-dimensional array of light sources such as, for example, a two dimensional LED matrix.

[0115] According to various implementations, the engineered illumination system comprises one or more optical elements that generate the ray bundle of illumination beams and propagate the illumination beams to the surface of the sample. Some examples of optical elements include a diffuser, a collimator, an optical fiber, optical fiber bundle, a light guide, a mirror, a beam splitter, a filter such as a bandpass colored filter or a polarization filter, and other suitable optics. In certain implementations, the one or more optical elements include at least a diffuser, a beam splitter, and a collimator.

[0116] According to various implementations, the engineered illumination system also includes a motion control device that is coupled to one or more components of the 3DSM system. The motion control device is configured to manipulate (rotate and/or translate) these components in order to provide relative rotation of one or more ray bundles with respect to the sample. In addition or alternatively, the motion control

device is configured to manipulate these components to provide engineered illumination to different portions of a large area sample.

[0117] In embodiments having a motion control device configured to manipulate system components for relative rotation of one or more ray bundles, the motion control device translates and/or rotates these components to different positions so that each ray bundle of multiple illumination beams is rotated to N different rotational positions in two orthogonal directions. At each incident angle, the motion control device holds the position of these system components while a camera takes intensity measurements of light from the illuminated sample. The motion control device includes one or more suitable components for controlling motion such as, for example, actuators, motors, servos, etc. The number of rotations in two orthogonal directions can be of different values. In some aspects, the number of rotations is in the range of 100 to 500 rotations. In one aspect, the number of rotations is greater than 100 rotations. In one aspect, the number of rotations is 400 with 20 rotations along one direction and 20 rotations along a second direction orthogonal to the first direction. In another aspect, the number of rotations is 100 with 10 rotations along one direction and 10 rotations along a second direction orthogonal to the first direction. In another aspect, the number of rotations is 225 with 15 rotations along one direction and 15 rotations along a second direction orthogonal to the first direction.

[0118] In certain cases, the motion control device rotates one or more ray bundles by manipulating (translating and/or rotating) one or more optical elements of a 3DSM system. For example, the 3DSM system may have a mirror that is configured to receive illumination beams of the ray bundle. In this case, the mirror can be rotated using the motion control device to change the rotational position of the beams. In addition or alternatively, the motion control device may manipulate the camera to capture reflected light from the sample at different viewing directions. In one aspect, the motion control device may manipulate the beam splitter to rotate the ray bundles. In another aspect, the motion control device may also manipulate the illumination device(s) and optical element(s) together to rotate the ray bundles.

[0119] In some embodiments, the motion control device is configured to manipulate one or more system components to acquire intensity images for a portion of a sample (e.g., a large area sample) and then manipulates the one or more system components so that the sensor(s) of the camera can acquire intensity images for a different portion

of the sample until intensity images over the entire large area sample are acquired. For example, the motion control device can translate the sample to different locations incrementally. In another example, the motion control device can translate the illumination device(s), optical element(s), and/or the camera relative to the sample. In one implementation, the motion control device includes an x-y stage. For example, the sample platform may be located on the x-y stage.

[0120] According to various implementations, a 3DSM system includes one or more cameras. Each camera has at least one imaging lens (e.g., a telecentric lens, a telephoto lens, or any lens with fixed or variable magnification) and one or more sensors configured to take intensity measurements (also referred to herein as “intensity images,” as “images,” and as “intensity distributions”) during a data acquisition phase of a 3DSM method. In one aspect, each sensor is an image sensor. Some examples of suitable sensors are CMOS sensors, a charge-coupled device (CCD), and other similar devices. Some examples of suitable imaging lens are telecentric lens, telephoto lens, lens with fixed or variable magnification, and other similar devices. A commercially-available example of a suitable image sensor is the DCC3260C manufactured by Thorlabs. In one aspect, a 3DSM system includes one camera. In another aspect, the 3DSM system includes multiple cameras that can take images from multiple different views respectively.

[0121] According to various implementations, a 3DSM system includes one or more processors (e.g., microprocessors) for executing instructions stored in memory for implementing functions of the 3DSM system including operations of a 3DSM method. For example, the one or more processors may send control signals to the camera to control exposures to acquire intensity images during a data acquisition phase. The one or more processors may also perform operations of the 3DSM method to determine 3D surface microgeometry and reflectance properties of a sample based on the intensity images. In some cases, the instructions are stored to an internal memory device of the controller. The internal memory device can include a non-volatile memory array for storing processor-executable code (also referred to herein as “instructions”) that is retrieved by the processor to perform various functions or operations described herein for carrying out various logic or other operations on the intensity measurements. The internal memory device also can store raw and/or processed intensity measurement data. In some implementations, the internal memory

device or a separate memory device can additionally or alternatively include a volatile memory array for temporarily storing code to be executed as well as measurements to be processed, stored, or displayed. In some implementations, the controller itself can include volatile and in some instances also non-volatile memory.

5 [0122] According to various implementations, a 3DSM system includes a communication interface in electrical communication with the controller and a display in communication with the communication interface. The controller is configured or configurable to output raw intensity measurements or processed data over the communication interface for display on the display. In addition or alternatively, the
10 controller can be output raw intensity measurements or processed data over a communication interface to an external computing system. Indeed, in some implementations, one or more of the functions of the 3DSM system may be performed by such an external computing system. In some implementations, the controller can be configured to store raw data as well as processed data over a communication interface
15 to an external memory device.

III. Examples of 3DSM systems and methods

[0123] In various implementations, the 3DSM system performs a 3DSM method generally comprising a data acquisition phase and an analysis phase. Optionally, the 3DSM method also includes one or more of a display phase, a calibration phase, and a
20 phase for calculating pre-determined sensor responses. During the data acquisition phase, one or more ray bundles are rotated to N different illumination directions and at each illumination direction, n intensity images are captured at different exposure settings by the camera. During the analysis phase, the surface normal at each surface pixel is determined. To determine the surface normal, the 3DSM method generates a
25 measured sensor response from the captured intensity images for each surface pixel, matches the measured response to one of a group of pre-determined sensor responses for different surface normals, and constructs a map of the surface normals over the surface of the sample (also referred to herein as the “object”). Optionally, during the analysis phase, the 3DSM method may also determine properties of the surface based
30 on the map of the surface normals. Because the illumination is engineered with a known distribution, a sensor response can be pre-calculated by taking a convolution of the engineered beam distribution function with all the possible surface normal directions at different illumination directions. The surface normal can then be

determined based on the best matching between captured sensor response and the pre-determined sensor response. A depth map can then be estimated from the surface normals. Reflectance properties, such as diffuse albedo, specular albedo and roughness can be estimated based on a BRDF model, such as the Ward model, the
5 Cook-Torrance model and the Blinn-Phong Model.

[0124] Various configurations of 3DSM systems for implementing 3DSM methods are described in this section. Certain details of the 3DSM methods of various embodiments are described in detail in Section V. Certain illustrations described in this section include some components of 3DSM systems in order to discuss particular
10 operations of 3DSM methods. It would be understood that only some of the components are illustrated in these simplified examples and that the illustrated 3DSM systems include additional system components such as those described with respect to **FIG. 2**.

[0125] **FIGS. 6A-6C** are schematic diagrams illustrating three operations of an data acquisition phase performed by a 3DSM system, according to various
15 implementations. **FIG. 6D** is a schematic diagram of operations in an analysis phase of the 3DSM method performed by the 3DSM system of **FIGS. 6A-6C**, according to various embodiments. The operations in the illustrated analysis phase use the intensity images captured during the data acquisition phase illustrated in **FIGS. 6A-6C** to
20 determine surface normals at each point along the surface and determine a depth map and/or reflectance properties based on the surface normals.

[0126] In **FIGS. 6A-6C**, components of the 3DSM system are shown to include an engineered illumination system **630** and a camera **660**. The 3DSM system also includes one or more processor(s) **622** shown in **FIG. 6D**. In the illustrated operations
25 of the data acquisition phase in **FIGS. 6A-6C**, the engineered illumination system **630** is shown providing the three L , M , and N ray bundles: a first ray bundle is incident on a point L of the surface **682** of an sample **680**, a second ray bundle is incident on a point M of the surface **682** of an sample **680**, and a third ray bundle is incident on a point N of the surface **682** of an sample **680**.

30 [0127] Although three ray bundles are shown in **FIGS. 6A-6C** and other examples for simplicity, it would be understood that the engineered illumination system can provide engineered illumination with an unlimited number of ray bundles, and that the

incident illumination is two-dimensional and can illuminate the entire surface or the entire area of the surface being analyzed. In each ray bundle, there are an infinite number of illumination beams, although three beams are shown for simplicity. Each of the ray bundles is engineered illumination that can have power values that follow
5 certain distributions such as, for example, a Gaussian distribution, a triangular distribution, a linear distribution, a random distribution, etc. During the data acquisition phase performed by the illustrated 3DSM system, the ray bundles are rotated to N different illumination directions.

[0128] FIGS. 6A-6C shows the data acquisition operations at three of the N
10 illumination directions. As shown, the ray bundles are rotated to three different illumination directions as shown sequentially in FIGS. 6A-6C. The reflected light R from the sample 680 propagates to the camera 660 and multiple images are captured with different exposure settings. At each illumination direction of the ray bundles shown FIGS. 6A-6C, one or more sensors of the camera are exposed twice, at
15 different exposure settings, to capture two intensity images. In FIG. 6A, the camera 660 uses an Exposure I setting to capture "Image IA" and an Exposure II setting to capture "Image IIA." In FIG. 6B, the camera 660 uses an Exposure I setting to capture "Image IB" and an Exposure II setting to capture "Image IIB." In FIG. 6C, the camera 660 uses an Exposure I setting to capture "Image IC" and an Exposure II
20 setting to capture "Image IIC." In another embodiment, additional images may be captured at each illumination direction. Although the illustrated example shows a particular angular range of illumination directions, the data acquisition phase may include a larger angular sampling to capture a more diverse bidirectional reflectance distribution function (BRDF) in other examples. In one case, for example, an angular
25 sampling of -45 degree to +45 degree with 1 degree step can be used.

[0129] In FIG. 6D, the images 691 captured under N different illumination directions and under different exposure (Exposure I and Exposure II) settings are received by one or more processors 622 of the 3DSM system in a signal from the camera 660 (shown in FIGS. 6A-6C). Because the illumination is engineered with a
30 known distribution, a sensor response 694 can be pre-determined by the one or more processors by taking a convolution of the engineered beam distribution function with all the possible surface normal directions at different illumination directions. Generating the pre-determined sensor response can be performed during the analysis

phase or during a process before the data acquisition phase, for example, during an optional calibration process. During the analysis phase, the one or more processors determine the surface normal at each surface pixel based on the best matching between the captured sensor response and the pre-determined sensor response. The one or more processors can then estimate a depth map from the surface normals. In addition or alternatively, the one or more processors can determine reflectance properties, such as diffuse albedo, specular albedo and roughness can be estimated based on a BRDF model, such as the Ward model, the Cook-Torrance model and the Blinn-Phong Model.

10 **[0130]** In various implementations, a 3DSM system captures multiple intensity measurements with different exposure settings at each illumination direction of the ray bundles. For example, one intensity measurement may be taken at an exposure setting of 1 millisecond and a second intensity measurement may be taken at an exposure setting of 100 millisecond. Generally, capturing multiple exposures allows
15 for a high dynamic range image to be captured.

[0131] In implementations with a large area sample, during the data acquisition phase the sample is translated to different translational positions and images are captured for a smaller field of view at each translational position. For example, the 3DSM system might include an x-y translation stage used to translate the sample
20 along x and y directions. Once the images are captured at each of the smaller fields of view, the normal map, depth map and reflectance property images determined for each smaller field of view and can be stitched together to achieve a larger field-of-view.

[0132] In one implementation, a 3DSM system includes a first polarization filter that is configured so that the engineered illumination passes through the first polarization filter before propagating to the sample. The 3DSM system also includes a second polarization filter that is placed in front of the camera. By changing the polarization stages of the second polarization filter placed in front of the camera, the diffuse and specular albedo images can be captured separately and then fitted into a
30 BRDF model to determine other reflectance properties

[0133] In various embodiments, the illumination direction of ray bundles is changed rapidly. For example, the illumination direction may be changed at a rate of 100

degree per second. In addition, the sensors may take intensity measurements at a rate of 100 frames per second.

[0134] FIG. 7 is a schematic drawing of a 3DSM system 700, according to an embodiment. The 3DSM system 700 comprises an engineered illumination system having optical elements of a diffuser 736, a mirror 737, and a beam-splitter 738. The engineered illumination system further comprises collimated illumination 735 from an illumination device (not shown). The 3DSM system 700 further comprises a camera 760. During the illustrated data acquisition phase, the diffuser 736 receives collimated illumination 735 and the collimated illumination is transmitted through the diffuser 736 spreading the illumination based on the diffuser's transmittance which typically follows a distribution such as a Gaussian distribution. For example, the diffuser 736 may have one of the transmission profiles shown in FIG. 3A. In FIG. 7, the diffuser 737 spreads out the collimated illumination into three illumination beams A1, A2, and A3. The illumination beams A1, A2 and A3 are with different intensities after being transmitting through the diffuser 736. The illumination beam A2 has the highest intensity and illumination beams A1 and A3 have lower intensities. The mirror 737 receives the three illumination beams A1, A2, and A3 and reflects these beams. The beam splitter 738 receives the reflected beams B1, B2, and B3 from the mirror 737 and reflects these beams. The reflected beams M1, M2, and M3 are propagated to the point M at the surface 782 of the sample 780. In the illustration, a ray bundle of three illumination beams M1, M2, and M3 is shown for simplicity, it would be understood that the engineered illumination provided to point M has an infinite number of illumination beams. In the illustration, only one ray bundle is shown at surface point M, it would be understood that infinite number of surface points receive infinite number of engineered illumination bundles. The surface 782 reflects an illumination beam and the reflected beam 792 is transmitted through the beam splitter 738 and received at the camera 760. The intensity distribution of the incident beams M1, M2, and M3 is the same of illumination beams A1, A2, and A3. That is, the incident beams M1, M2, and M3 are engineered with a known distribution function which is the same distribution function of the illumination beams A1-A3. Although three beams are shown for simplicity, it would be understood that the same would apply for a larger number of beams.

[0135] FIG. 8 is a sensor response captured without engineered illumination. In this example, the intensity image is captured with incident light parallel to a camera's optical axis. The incident beam is not engineered and is only collimated illumination. The sample is a chrome sphere which has mirror-like reflection and surface normal elevation angle changed from 0 to 90 degree.

[0136] FIG. 9 is a sensor response determined using the 3DSM system of FIG. 7. In this example, the intensity image is captured with engineered illumination following a Gaussian distribution implemented with the use of a diffuser. By comparing the intensity images of FIG. 8 and FIG. 9, it is shown that under regular collimated illumination as illustrated in FIG. 8, only a few pixels of the camera measure intensity. In this case, the limited number of pixel values would be available to estimate a surface normal. In comparison, under engineered illumination as shown in FIG. 9, the sensor response is much broader, and many more pixel values can be used for surface normal estimation. Technical advantages of certain embodiments using engineering illumination with a known distribution function over using collimated light may include that the spatial range of surface normals to be constructed can be significantly increased and/or each surface normal can be estimated with higher angular resolution.

[0137] FIG. 10A is a schematic drawing of components of a 3DSM system 800, according to an embodiment. The 3DSM system 800 comprises an engineered illumination system having optical elements including a collimator 834, a fiber bundle 836, a combination filter 835, a mirror 837, and a beam-splitter 838. The 3DSM system 800 further comprises a camera 860. FIG. 10B shows an example layout of the combination filter 736 shown in FIG. 10A, according to one implementations. In FIG. 10B, the combination filter 835 is a combination of three neutral density (ND) filters with annulus shape: a first ND filter 895, a second ND filter 896, and a third ND filter 897. Although three ND filters are shown, other implementations may use additional filters. The first ND filter 895 in the middle has the highest transmittance, and transmittance of the second ND filter 896 and the third ND filter 897 is gradually decreased. FIG. 10C is another example layout of the combination filter 736 shown in FIG. 10A, according to an implementation. In this example, the filter has a randomly distributed transmission. FIG.10D is another example of the combination

filter 736 shown in FIG. 10A, according to an implementation. In this example, the filter has a linear gradient distributed transmission.

[0138] Returning to FIG. 10A, during the illustrated data acquisition phase, illumination passes through the fiber bundle 836 to the combination filter 835. The illumination passing through the different partitions of the combination filter 835 are engineered into three beams with different intensities from different points on combination filter 835. After passing through the collimator 834, the beams A1, A2, and A3 have different intensities, which is similar to the beams from the diffuser 836 shown in the configuration of FIG 2A. The illumination beam A2 has the highest intensity and illumination beams A1 and A3 have lower intensities. The mirror 837 receives the three illumination beams A1, A2, and A3 and reflects these beams. The beam splitter 838 receives the reflected beams B1, B2, and B3 from the mirror 837 and reflects these beams. The reflected beams M1, M2, and M3 are propagated to the point M at the surface 882 of the sample 880. In the illustration, a ray bundle of three illumination beams M1, M2, and M3 is shown for simplicity, it would be understood that the engineered illumination provided to point M has an infinite number of illumination beams. The surface 882 reflects an illumination beam and the reflected beam 892 is transmitted through the beam splitter 838 and received at the camera 860. The intensity distribution of the incident beams M1, M2, and M3 is the same as the intensity distribution of illumination beams A1, A2, and A3.

[0139] FIG. 41 is a schematic drawing depicting a data acquisition operation of a 3DSM system 4100, according to an embodiment. The 3DSM system 4100 comprises an illumination source 4134 and an engineered illumination system having optical elements including a diffuser 4136, an illumination collimator 4139, a mirror 4137, and a beam-splitter 4138. The 3DSM system 4100 further comprises a camera 4160. During the illustrated data acquisition phase, the light from an illumination source 4134 is passed through the diffuser 4136, which is engineered with certain transmission distribution, such as a Gaussian distribution. The light passed through the diffuser 4136 is then collimated by an illumination collimator 4139. The beams A1, A2, and A3 are further reflected by a beam splitter 4138 and are projected onto a surface 4182 of a sample 4180. The incident beams M1, M2, and M3 are also engineered with a known intensity distribution that follows the transmission profile of the diffuser 4136.

A. Manipulation of Illumination Direction

[0140] In certain implementations, a 3DSM system is configured to manipulate the illumination direction of one or more ray bundles. For example, a 3DSM system may include a moving mirror to manipulate the direction of illumination beams reflected from the mirror. **FIGS. 11A-11B** are schematic diagrams illustrating data acquisition operations performed by a 3DSM system **900** with a rotating (spinning) mirror **937**, according to an aspect. **FIG. 12** is a schematic diagram illustrating a data acquisition operation performed by the 3DSM system **900** of **FIGS. 11A-B**. In one case, the diagrams in **FIGS. 11A-11B** and **FIG. 12** illustrate three operations of a data acquisition phase. In another case, the diagrams in **FIGS. 11A-11B** illustrate two operations of operations of a data acquisition phase and the diagram in **FIG. 12** illustrates an operation of another data acquisition phase.

[0141] The 3DSM system **900** comprises an engineered illumination system having optical elements including a diffuser **936**, a rotating mirror **937**, and a beam-splitter **938**. The engineered illumination system also includes collimated illumination **935** from an illumination device (not shown). The 3DSM system **900** further comprises a camera **960**, for example, of a camera. The 3DSM system **900** also includes an x-axis, a y-axis, and a z-axis (not shown) orthogonal to the x-axis and the y-axis. The 3DSM system **900** also includes a motion control device **932** coupled to the rotating mirror **937**. The motion control device **932** is configured to rotate the rotating mirror **937** about the x-axis and the y-axis (two orthogonal rotational directions). The illustrations show the rotating mirror **937** being rotated along the x-axis between a first position (dotted line) and the current second position (solid line).

[0142] In **FIGS. 11A** and **11B**, the diffuser **936** receives collimated illumination **935** and the collimated illumination is transmitted through the diffuser **936** spreading the illumination based on the diffuser's transmittance distribution. The mirror **937** receives the illumination beam **A2** and reflects it. The beam splitter **938** receives the reflected beam **B2** from the mirror **937** and reflects it. The reflected beam **M2** is propagated to a point at the surface **982** of the sample **980**. A surface **982** of a sample **980** reflects the illumination beam and the reflected beam **992**, **993** is transmitted through the beam splitter **938** and the reflected transmitted beam **992**, **993** is received at the camera **960**.

[0143] In FIG. 12, the diffuser 936 receives collimated illumination 935 and the collimated illumination is transmitted through the diffuser 936 spreading the illumination based on the diffuser's transmittance distribution. The rotating mirror 937 receives the illumination beam A2 and reflects it. The surface 982 of the sample 980 reflects the illumination beam B2 and the reflected beam 994 is transmitted through the beam splitter 938 and the reflected transmitted beam 994 is received at the camera 960. The reflected transmitted beam 994 is received at the camera 960. In FIG. 12, when the rotating mirror 937 is oriented with a large oblique angle, the illumination beam B2 is directly reflected from the rotating mirror 937 onto the surface 982 without bouncing from the beam splitter 938. This illustrated configuration allows for a much larger beam incident angle.

[0144] In FIGS. 11A-11B, the direction of the incident illumination beam M2 can be changed by rapidly spinning the rotating mirror 937 with the motion control device 932, such as a rotation stage, a gimbal mount or a goniometer. In FIG. 12, the direction of the incident illumination beam B2 can be changed by rapidly spinning the rotating mirror 937 with the motion control device 932. Although a single incident beam is shown in FIGS. 11A-B and FIG. 12, it would be understood that the same system configuration can be used to direct incident beam bundles of illumination beams across the full field-of-view such as shown in FIGS. 6A-6C.

[0145] A 3DSM system configured to manipulate the engineered illumination direction of one or more ray bundles with a spinning mirror may provide one or more technical advantages. First, one technical advantage is that a large number of angular samplings of the BRDF can be captured around the predominant surface normal, and very fine sampling step may be achieved by adjusting the mirror spinning angle. Such an approach may allow for unbiased estimation of surface normals for specular surfaces that are relatively smoother. Second, one technical advantage is that this implementations may avoid shadow effects, which are common for photometric stereo techniques. Third, another technical advantage is that by using engineered illumination the range of surface normals that can be estimated is significantly extended. If not using engineered illumination, the range of surface normals to be estimated is solely determined by the scanning range of the incident light. But with engineered illumination the range of surface normals that can be measured is increased, and the enhancement is proportional to the bandwidth of the engineered

illumination distribution. Fourth, another technical advantage is that the camera and illumination do not need to be placed at far distance in order to fulfill the orthographic assumptions. Therefore, the whole system can be built in a compact form factor and is able to capture data at a closer distance to achieve better spatial and depth resolution and accuracy.

[0146] For samples having surfaces with large slopes, additional illumination sources can be included at an oblique angle to improve estimation. FIG. 13 illustrates an example of the placement of additional illumination sources. Although only two illumination sources are shown in the illustrated example, additional sources may be used in other embodiments.

[0147] FIG. 13 is a schematic diagram illustrating a 3DSM system 1000 with a rotating (spinning) mirror 1037, according to an aspect. The 3DSM system 1000 comprises an engineered illumination system having optical elements including a diffuser 1036, a rotating mirror 1037, and a beam-splitter 1038. The engineered illumination system also includes three illumination devices: a first illumination device 1010 configured to provide collimated illumination 1035, a second illumination device 1011, and a third light source 1012. The 3DSM system 1000 further comprises a camera 1060. The 3DSM system 1000 also includes an x-axis, a y-axis, and a z-axis (not shown) orthogonal to the x-axis and the y-axis. The 3DSM system 1000 also includes a motion control device 1032 coupled to the rotating mirror 1037. The motion control device 1032 is configured to rotate the rotating mirror 1037 about the x-axis and the y-axis (two orthogonal rotational directions). The illustrations show the rotating mirror 1037 being rotated along the x-axis between a first position (dotted line) and the current second position (solid line). The diffuser 1036 receives collimated illumination 1035 and the collimated illumination is transmitted through the diffuser 1036 spreading the illumination based on the diffuser's transmittance distribution. Although a single illumination beam from the diffuser 1036 is shown for simplicity, it would be understood that multiple beams are passed to the rotating mirror 1037. The rotating mirror 1037 receives the illumination beam A2 and reflects it. The beam splitter 1038 receives the reflected beam B2 from the mirror 1037 and reflects it. The reflected beam M2 is propagated to a point at the surface 1082 of the sample 1080. A surface 1082 of a sample 1080 reflects the incident beam. Illumination reflected from the surface 1082 is transmitted through the beam splitter

1038. The beam **1093** propagated from the beam splitter **1038** is received at the camera **1060**.

[0148] **FIGS. 14A-14B** are schematic diagrams illustrating data acquisition operations performed by a 3DSM system **1100** configured for illumination direction manipulation, according to an embodiment. The 3DSM system **1100** comprises an engineered illumination system having optical elements including a diffuser **1136**, a collimator **1134** with an optical axis **1133**, an illumination array **1135**, a mirror **1137**, and a beam-splitter **1138**. The 3DSM system **1100** further comprises a camera **1160**. As shown, the illumination array **1135** is placed behind the collimator **1134**.

[0149] Different types of illumination can be used in the illumination array **1135**, such as LEDs and optical fibers. In the illustrated example, the middle illumination element (e.g., LED) is located at the focal point of the collimator **1134**. In other examples, other positions may be used. Each circle of the illumination array **1135** represents an individual illumination element. A solid circle denotes an illumination element that is turned on, and empty circle represent an illumination that is turned off. By turning each individual illumination element on and off, the direction of incident beam M2 to the surface **1182** of the sample **1180** can be manipulated. In **FIGS. 14A-14B**, the illumination array **1135** includes five illumination elements **1191**, **1192**, **1193**, **1194**, and **1195**. In other example, more or fewer illumination elements can be used. In **FIG. 14A**, the middle illumination element **1193** of the illumination array **1135** is illuminated. In **FIG. 14B**, an illumination element **1191** of the illumination array **1135** is illuminated. The collimator **1134** receives the illumination from the activated element.

[0150] In the operations illustrated in **FIGS. 14A-14B**, the diffuser **1136** receives collimated illumination from the collimator **1134**. Illumination transmitted through the diffuser **1136** is spread based on the diffuser's transmittance distribution. The mirror **1137** receives the illumination beams and reflects them. For simplicity, a single beam A2 is shown reflected by mirror **1137**. The beam splitter **1138** receives the reflected beam A1 from the mirror **1137** and reflects it. The reflected beam M2 is propagated to a point at the surface **1182** of the sample **1180**. A surface **1182** of a sample **1180** reflects the illumination beam and the reflected beam **1198** is transmitted through the beam splitter **1138** and the reflected transmitted beam **1198** is received at

camera **1160**. During operation, the 3DSM system **1100** can manipulate the direction of the incident beam M2 by turning individual illumination elements on and off.

B. Calibration Process

[0151] In certain implementations, the 3DSM system generates engineered
5 illumination of ray bundles that are aligned to the same direction. In **FIG. 6A-6C**, for example, the center illumination beams L2, M2, and N2 of the three ray bundles are parallel to each other. In other implementations, however, the illumination beams may diverge or converge due to imperfect beam collimation. In one implementation, the 3DSM includes a calibration process that can be used to estimate the offset of the
10 incident beams from the ideal condition discussed above.

[0152] The directions of incident beams in a 3DSM system (e.g., incident beams L2, M2, and N2 in **FIGS. 6A-6C**) can be controlled by illumination control (e.g., using the spinning mirror **937** in **FIG. 11A**) or based on the knowledge of an illumination array (e.g., illumination array **1135** in **FIG. 14A**). To account for
15 misalignments in a 3DSM system, a calibration process can be used to determine offsets and the offsets can be accounted for in the analysis phase.

[0153] Below are examples of calibration processes that use various elements as reference objects. The illustrated examples can be used in any of the system configurations described herein.

1. Mirror

20

[0154] In other implementations, a system calibration process uses a mirror. One example of a system calibration process using a mirror **1480** is shown in **FIGS. 15A-15C**, in accordance with an embodiment. **FIGS. 15A-15C** illustrate three data acquisition operations during the calibration process implemented by a 3DSM system,
25 according to an embodiment. During the calibration process, the mirror **1480** is placed as the sample being analyzed by the 3DSM system, and directions of the incident beams are changed. The 3DSM system includes a camera **1460**. During the calibration process, the illumination reflected from mirror **1480** is received at the camera **1460** and intensity images are captured at all the different directions. **FIGS. 15A-15C**
30 illustrate three directions of the incident beams. The 3DSM system has one or more processors (e.g., processor(s) **22** in **FIG. 2**) that can calibrate the deviation of the incident beams based on the reflection from the mirror **1480**.

[0155] FIGS. 16A-16B are illustrations showing the calibrated offset of incident beams resulting from the calibration process using a mirror, according to an embodiment. FIG. 16A shows an illustration of the calibrated offset of incident beams in terms of the zenith angle at each pixel. FIG. 16B shows an illustration of the calibrated offset of incident beams in terms of the azimuth angle at each pixel. Ideally the values for the zenith angle and azimuth angle should be the same at each pixel if a perfect collimation is achieved. But in practice, the values are different at each pixels as shown in FIGS. 16A and 16B. In one implementation, the 3DSM method uses the results of the calibration process to account for the offset in the analysis phase to compensate for any misalignments.

[0156] FIGS. 17A and 17B are illustrations showing system alignment using the calibration process using a mirror as a reference object, according to an embodiment. In FIG. 6A, the central beams L2, M2, and N2 in each ray bundle are perpendicular to the object surface and the reflected beam R is parallel to these central beams. In certain implementations, this parallel arrangement is preferred. In order to have this parallel alignment, alignment of different system components in the illumination path and imaging path is required such as can be accomplished using a calibration process described herein. In one implementation, the calibration process uses a mirror in a similar method as shown in FIGS. 15A-15C for active alignment of the optics (also referred to herein as optical elements), the camera, and the object plane, for example, by manipulating a sample platform. FIGS. 17A and 17B are examples of captured images of a reference mirror surface using the 3DSM system with the configuration shown in FIGS. 11A-11B. FIG. 17A is a captured image that is uniform, which indicates alignment of different optical components. FIG. 17B is a captured image that is not uniform, which indicates poor alignment of one or more optical components. The calibration method using a mirror works because the mirror is flat and can only reflect light in one direction, and thus any misalignment can result in partially reflected beams from the mirror.

2. Chrome Sphere(s)

[0157] In other implementations, a system calibration process uses one or more chrome spheres. An example of system calibration process using a chrome sphere array 1580 is shown in FIGS. 18A-18C, in accordance with an embodiment. Different number of chrome spheres can be used in the chrome sphere array 1580.

[0158] FIGS. 18A-18C illustrate three data acquisition operations during the calibration process implemented by a 3DSM system 1500, according to an embodiment. During the calibration process, the chrome sphere array 1580 is placed as the object, and directions of the incident beams are changed. The 3DSM system 5 1500 includes a camera 1560. During the calibration process, the illumination reflected from the chrome sphere array 1580 is received at the camera 1560 and intensity images are captured at all the different directions. Because each sphere has known geometry, when the incident beams change direction, different parts of the sphere are highlighted. The 3DSM system has one or more processors (e.g., 10 processor(s) 22 in FIG. 2) that can calibrate the incident beam directions based on the reflection from the chrome sphere array 1580.

[0159] FIGS. 19A and 19B are captured images of a single chrome sphere of a chrome sphere array when the incident beams are changed to two different directions, and different parts of sphere show highlight, according to an implementation. Based 15 on the position of the highlight, the direction of the incident beam can be estimated.

[0160] FIGS. 20A and 20B are illustrations of examples of calibrated zenith angle and azimuth angle for 169 different incident beam directions using a calibration process of the 3DSM system 1500 illustrated in FIGS 17A-17C, according to an implementation.

20 3. Mirror and chrome sphere(s)

[0161] In other implementations, a system calibration process uses a mirror and one or more chrome spheres. FIGS. 21A-21C is a schematic diagram of a 3DSM system 2000 implementing a system calibration process using a combination of a mirror 2080 and a single chrome sphere 2081, in accordance with an embodiment. During the 25 calibration process, the mirror 2080 and the chrome sphere 2081 are placed as the object being imaged, and the directions of the incident beams are changed. The 3DSM system 2000 includes a camera 2060. During the calibration process, the illumination reflected from the chrome sphere 2081 and from the mirror 2080 is received at the camera 2060 and intensity images are captured at all the different directions. The 30 offset of beams from ideal parallel condition is calibrated using the method depicted in FIGS. 15A-15C and FIGS. 16A-16B, and the incident beam directions are calibrated using the method depicted in FIGS. 18A-18C, FIGS. 19A-19B, and FIGS.

20A-20B. By using combined mirror and chrome sphere these two calibration processes can be performed simultaneously.

C. Pre-determined sensor responses (also referred to herein as pre-computed sensor responses)

5 [0162] Because the engineered illumination has a known intensity distribution, sensor response can be pre-determined by taking the convolution of the engineered beam distribution function with all the possible surface normal directions at different illumination directions. In various implementations, a 3DSM method includes operations during a data acquisition phase that acquire intensity images and
10 operations during an analysis phase that use the intensity images to determine a measured sensor response for each surface point and matches the measured sensor response to a pre-determined sensor response to determine a surface normal at each surface point that corresponds to a pixel of the image data of the surface. A surface point is sometimes referred to herein as a “pixel” or a “surface pixel.”

15 [0163] FIG. 22 depicts a series of pre-determined sensor responses of a single sensor pixel, according to an embodiment. Each sensor response is in the form of a three-dimensional plot. In each sensor response plot, the x-axis and y-axis represents the incident beam direction changed in the x and y directions respectively, and the z-axis is normalized intensity of the sensor response. Each plot is the pre-determined
20 sensor response with a different surface normal vector. The illustrated series of p pre-determined sensor responses includes a first sensor response 1902, a second sensor response 1904, ..., a $(p-1)^{\text{th}}$ sensor response 1906, a p^{th} sensor response 1908.

[0164] FIG. 23 is a schematic representation of the operation of matching a measured sensor response for a single sensor pixel corresponding to a surface pixel
25 1911 to one of a series of pre-determined sensor responses, according to an embodiment. In FIG. 23, the captured response 1912 is calculated for a single pixel 1911 when the illumination changed in both x and y directions, and a best matched pre-determined sensor response 1914 can be found based on different metrics, such as correlation and minimum difference. The surface normal vector of the matched pre-
30 determined sensor response is then assigned to that pixel. The same sensor response matching process is repeated for all the pixels in the captured images.

D. Examples of microgeometry and reflectance properties measurements, and related renderings

[0165] FIG. 24A is a photograph of a leather sample. The area 2301 of the leather sample (denoted by the rectangle in the photograph) was analyzed by a 3DSM system of an implementation to measure microgeometry in the form of a depth map and reflectance properties. According to one aspect, the area 2301 may be the portion of the sample within the field-of-view of the camera.

[0166] FIG. 24B is an illustration of a measured depth map of the area 2301 of the leather sample shown in FIG. 24A as analyzed by the 3DSM system. FIG. 24C is a surface normal map of the portion 2301 of the leather sample as analyzed by the 3DSM system. FIG. 24D is a measured diffuse map of the portion 2301 of the leather sample as analyzed by the 3DSM system. FIG. 24E is a measured specular map of the area 2301 of the leather sample as determined by the 3DSM system. FIG. 24F is a measured surface roughness map of the area 2301 of the leather sample as determined by the 3DSM system.

[0167] FIG. 25A is a photograph of a coin. FIG. 25B is a 3D rendering of the coin shown in FIG. 25A that is generated by a 3DSM system using a measured depth map, according to an embodiment. FIG. 25C is graph having a measured depth curve measured along the black line of the coin shown in FIG. 25A as determined by the 3DSM system. The depth is measured in micron.

[0168] FIGS. 26A-26D are physically-based renderings based on measured microgeometry and reflectance properties of samples measured using an 3DSM system according to an implementation. FIG. 26A is a rendering of a wool sample. FIG. 26B is a rendering of green leather sample. FIG. 26C is a rendering of a rock sample. FIG. 26D is a rendering of a laminated wood sample.

E. Wavelength and Polarization control

[0169] In certain implementations, a 3DSM system controls wavelength and/or polarization of the engineered illumination, the light from the sample surface (in optical path between the camera and the sample), or both the engineered illumination and the light from the sample surface. In these cases, the 3DSM includes one or more wavelength and/or polarization control devices. To control the wavelength of the engineered illumination, the reflected light, or the light at another point in the optical

path to the camera, a control device such as filter wheel loaded with different spectral filters or a liquid crystal tunable filter can be used. Alternatively, different light sources with different wavelength can also be used to control the wavelength of the engineered illumination. To control the polarization, a polarizer rotated at different positions or a filter wheel loaded with differ polarizers can be used.

[0170] FIGS. 27A-27C are schematic diagrams depicting three operations of a data acquisition phase implemented by a 3DSM system 2700 configured to control wavelength and polarization of the engineered illumination, in accordance with an embodiment. The 3DSM system 2700 comprises an engineered illumination system 2730, a camera 2760, and a wavelength/polarization control device 2739 in communication with the engineered illumination to change the wavelength and/or polarization states of the engineered illumination. In one case, the wavelength/polarization control device 2739 is a component of the engineered illumination system 2730. The engineered illumination's wavelength and polarization can be controlled alone or be controlled together, and images are captured under different illumination directions and under different exposures in a way that is similar to the way shown in FIGS. 6A-6C. In the illustrated operations, the engineered illumination system 2730 is shown providing three ray bundles: a first ray bundle is incident on a point L of the surface 2782 of an sample 2780, a second ray bundle is incident on a point M of the surface 2782 of the sample 2780, and a third ray bundle is incident on a point N of the surface 2782 of the sample 2780.

[0171] FIGS. 27A-27C show the data acquisition operations at three of the N illumination directions of the ray bundles. The reflected light R from the sample 2780 propagates to the camera 2760 and multiple images are captured at different wavelength/polarization states at each of the two exposure settings "Exposure A" and "Exposure B." Although three illumination directions and two exposures at different settings are shown for simplicity, it would be understood that data acquisition can include additional illumination directions and/or additional exposures. The captured images are then communicated in a signal to the one or more processors to analyze the images for different wavelength and polarization states. During an analysis phase, the one or more processors use the captured images to construct a map of surface normals, a depth map and maps of reflectance properties, all measured at different wavelength and/or polarization states.

[0172] FIGS. 28A-28C are schematic diagrams illustrating three operations of a data acquisition phase that control wavelength and polarization of the reflected light 2898 from the surface 2882 of the sample 2880 using a 3DSM system 2800, in accordance with an embodiment. The 3DSM system 2800 comprises an engineered illumination system 2830, a camera 2860, and a wavelength/polarization control device 2839 in communication with the reflected light 2898 to change the wavelength and/or polarization states. In one case, the wavelength/polarization control device 2839 is a component of the engineered illumination system 2830. The wavelength and polarization of the reflected light 2898 can be controlled alone or be controlled together, and images are captured under different illumination directions and under different exposures in a way that is similar to the way shown in FIGS. 6A-6C. In the illustrated operations, the engineered illumination system 2830 is shown providing three ray bundles: a first ray bundle is incident on a point L of the surface 2882 of an sample 2880, a second ray bundle is incident on a point M of the surface 2882 of the sample 2880, and a third ray bundle is incident on a point N of the surface 2882 of the sample 2880. FIGS. 28A-2C shows the data acquisition operations at three of the N illumination directions of the ray bundles. The reflected light R from the sample 2880 propagates to the camera 2860 and multiple images are captured at different wavelength/polarization states at each of the two exposure settings “Exposure A” and “Exposure B.” Although three illumination directions and two exposures at different settings are shown for simplicity, it would be understood that data acquisition can include additional illumination directions and/or additional exposures. The captured images are then communicated in a signal to the one or more processors to analyze the images for different wavelength and polarization states. During operations of an analysis phase of the 3DSM method, the one or more processors use the captured images to construct a map of surface normal, a depth map and maps of reflectance properties, all measured at different wavelength and/or polarization states.

[0173] FIGS. 29A-29C are schematic diagrams illustrating three operations of a data acquisition phase that control wavelength and polarization of both the engineered illumination and the reflected light 2998 from the surface 2982 of the sample 2980 using a 3DSM system 2900, in accordance with an embodiment. The 3DSM system 2900 comprises an engineered illumination system 2930, a camera 2960, a first wavelength/polarization control device 2938 in communication with the engineered illumination to change the wavelength and/or polarization states of the engineered

illumination, and a second wavelength/polarization control device **2939** in communication with the reflected light **2998** to change the wavelength and/or polarization states of the reflected light **2988**. In one case, one or both of the first and second wavelength/polarization control devices **2938**, **2939** are components of the engineered illumination system **2930**. The engineered illumination's wavelength and polarization can be controlled alone or be controlled together, and the wavelength and polarization of the reflected light **2998** can also be controlled alone or be controlled together.

[0174] Images are captured under different illumination directions and under different exposures in a way that is similar to the way shown in **FIGS. 6A-6C**. In the illustrated operations, the engineered illumination system **2930** is shown providing three ray bundles: a first ray bundle is incident on a point L of the surface **2982** of an sample **2980**, a second ray bundle is incident on a point M of the surface **2982** of the sample **2980**, and a third ray bundle is incident on a point N of the surface **2982** of the sample **2980**. **FIGS. 29A-29C** show the data acquisition operations at three of the N illumination directions of the ray bundles. The reflected light R from the sample **2980** propagates to the camera **2960** and multiple images are captured at different wavelength/polarization states at each of the two exposure settings “Exposure A” and “Exposure B.” Although three illumination directions and two exposures at different settings are shown for simplicity, it would be understood that data acquisition can include additional illumination directions and/or additional exposures. The captured images are then communicated in a signal to the one or more processors to analyze the images for different wavelength and polarization states. During an analysis phase, the one or more processors use the captured images to construct a map of surface normals, a depth map and maps of reflectance properties, all measured at different wavelength and/or polarization states.

[0175] **FIG. 30** is a schematic diagram illustrating an operation of a data acquisition phase of a 3DSM system **3000** that controls wavelength and polarization of both the engineered illumination and the reflected light **3098** from the surface **3082** of the sample **3080**, in accordance with an embodiment. The 3DSM system **3000** comprises an engineered illumination system having an illumination source **3034** and optical elements including a first wavelength/polarization control device **3038**, a collimator **3033**, a diffuser **3036**, a rotating mirror **3037**, and a beam-splitter **3038**. The 3DSM

system **3000** further comprises a second wavelength/polarization control device **3039** and the camera **3060**. The 3DSM system **3000** also includes an x-axis, a y-axis, and a z-axis (not shown) orthogonal to the x-axis and the y-axis. The 3DSM system **3000** also includes a motion control device **3032** coupled to the rotating mirror **3037**. The motion control device **3032** is configured to rotate the rotating mirror **3037** about the x-axis and the z-axis (two orthogonal rotational directions). The first wavelength/polarization control device **3038** receives illumination propagated from the illumination source **3038** and the collimator **3033** receives light propagated from the first wavelength/polarization control device **3038**. During operation, the diffuser **3036** receives collimated illumination **3035** from the collimator **3033** and the diffuser **3036** spreads the illumination based on the diffuser's transmittance distribution. For simplicity, three illumination beams A1, A2, A3 are shown. The rotating mirror **3037** receives the illumination beams and reflects them. The beam splitter **3038** receives the reflected beams B1, B2, B3, from the mirror **3037** and reflects them. The surface **3082** of the sample **3080** receives the incident beams L1, M2, and N3 at the points L, M, and N respectively. Light reflected from the surface **3082** is transmitted through the beam splitter **3038**. The second wavelength/polarization control device **3039** receives light transmitted through the beam splitter **3038**. Light propagated by the second wavelength/polarization control device **3039** is received at the camera **3060** and multiple images are captured at different wavelength/polarization states. During operation, the first wavelength/polarization control device **3038** controls the wavelength and/or polarization states of the light propagated to the collimator **3033** and/or the second wavelength/polarization control device **3039** controls the wavelength and/or polarization states of the light reflected from the sample **3080** and transmitted through the beam splitter **3038**. During operation, light is propagated to the camera **3060** and multiple images are captured at different wavelength/polarization states at each of the multiple exposure settings. The captured images are communicated in a signal to the one or more processors to analyze the images for different wavelength and polarization states.

[0176] In **FIG. 30**, the first wavelength/polarization control device **3038** implements wavelength and polarization control of the engineered illumination and the second wavelength/polarization control device **3039** implements wavelength and polarization control of the reflected light from the sample surface. To control the wavelength a device such as filter wheel loaded with different spectral filters or liquid

crystal tunable filter can be used. To control the polarization a polarizer rotated at different positions or a filter wheel loaded with different polarizers can be used. Different light sources with different wavelength can also be used to control the wavelength of engineered illumination.

5 *F. Controlled Motion of Sample Surface*

[0177] In certain implementations, a 3DSM system is configured to control the motion of the sample surface. For example, a 3DSM system may include a motion control device coupled to the sample platform to control the translation, tilt, and rotation of the sample surface.

10 [0178] FIGS. 31A-31B are schematic diagrams illustrating three operations of a data acquisition operations performed by a 3DSM system 3100 including a motion control device 3132 coupled to a sample platform 3040 for manipulating the position of the sample surface, according to an implementation. The 3DSM system 3100 comprises a sample platform 3040, an engineered illumination system 3130, a motion
15 control device 3132 coupled to a sample platform 3140. In the illustrated operations of the data acquisition phase in FIGS. 31A-31C, the incident illumination includes three ray bundles: a first ray bundle is incident on a point L of the surface 3182 of an sample 3180, a second ray bundle is incident on a point M of the surface 3182 of an sample 3180, and a third ray bundle is incident on a point N of the surface 3182 of an
20 sample 3180. Although three ray bundles with three beams are shown for simplicity, it would be understood that larger numbers of beams and/or larger number of ray bundles may be used. The motion control device 3132 is configured to control the position of the sample including one or more of translation, tilt, and rotation applied to the sample surface. At each controlled position of the sample 3180, the camera
25 captures images under different illumination directions and under different exposures settings similar to the images captured in FIGS. 6A-6C. Although three illumination positions are shown, it would be understood that additional illumination positions may be implemented. During operation, the image data of the captured images is communicated in a signal to the one or more processors and the processors use the
30 image data to construct a map of surface normals, a depth map and maps of reflectance properties at each controlled position.

[0179] In implementations where the surface of a sample is larger than the camera's field-of-view, the sample surface can be translated along different directions in the sample plane, and images captured at different translation positions. The images captured at each controlled position can be used to measure the map of surface normals, depth map, and reflectance properties at each translation position and then this data can be stitched together.

- Height mapping and anisotropic properties

[0180] In some implementations, a 3DSM system further comprises a stage that is configured to adjust the distance between the surface of the sample and the camera to bring the surface into focus. In one implementation, the distance between the surface and the camera can be adjusted gradually and images captured at each distance. Images captured at the different distances can be used to determine properties and can be combined together to extend the depth of field of the camera, and can also be processed to estimate a height map based on the depth from defocus method. This height map can be combined with the depth map measured using the engineered illumination.

[0181] In some scenarios, a surface may present anisotropic reflection. In this case, it can be useful to measure properties at different rotational positions. In one implementation, the 3DSM system further comprises a rotational stage that can be used to rotate the sample surface, and the 3DSM system measures surface normal, depth, and reflectance properties at different rotation positions. The surface can be tilted to change the geometric relationship among illumination, surface normal, and camera viewing direction.

[0182] In some cases, images captured at these additional height and/or rotational positions can be fitted into a BRDF model together with the images captured at different illumination directions, and can provide improved reflectance properties measurement.

G. Controlled Motion of Engineered Illumination and Camera

[0183] In certain implementations, a 3DSM system is configured to control the motion of the engineered illumination and the camera together in unison. For example, a 3DSM system may include a motion control device individually coupled

each of the engineered illumination system and the camera individually or may be coupled with both.

[0184] FIGS. 32A-32B are schematic diagrams illustrating three operations of a data acquisition phase performed by a 3DSM system 3200 configured to control the motion of the engineered illumination and the camera, according to an embodiment. Engineered illumination and camera can be controlled together or be controlled individually by applying different motion controls such as translation, tilt, and rotation. At each controlled position, images are captured under different illumination directions and under different exposures in a way that is similar to the operations described with respect to FIGS. 6A-6C. The 3DSM system 3200 comprises an engineered illumination system 3230, a camera 3260, and a motion control device 3232 coupled to both the engineered illumination system 3230 and the camera 3260. In the illustrated operations of the data acquisition phase in FIGS. 32A-32C, the incident illumination includes three ray bundles: a first ray bundle is incident on a point L of the surface 3282 of an sample 3280, a second ray bundle is incident on a point M of the surface 3282, and a third ray bundle is incident on a point N of the surface 3282. Although three ray bundles with three beams are shown for simplicity, it would be understood that larger numbers of beams and/or larger number of ray bundles may be used. The motion control device 3232 is configured to control one or more of translation, tilt, and rotation applied to the engineered illumination system 3230 and the camera 3260. At each controlled position, the camera 3260 captures images under different illumination directions and under different exposures settings similar to the images captured in FIGS. 6A-6C. Although three positions are shown, it would be understood that additional positions may be implemented. During operation, the image data of the captured images is communicated in a signal to the one or more processors and the processors use the image data to construct a map of surface normals, a depth map, and maps of reflectance properties at each controlled position.

[0185] In implementations where the surface of a sample is larger than the camera's field-of-view, the engineered illumination and camera can be translated together or be translated individually along different directions parallel to the sample plane. During data acquisition, the camera can take images at different translation positions. The images captured at each controlled position can be used to measure a map of surface

normals, a depth map, and maps of reflectance properties at each translation position and then this data can be stitched together.

H. Wavelength/polarization control and Motion Control

[0186] In one implementation, a 3DSM system combines wavelength/polarization control and motion control to capture images at different wavelength, different polarization states, and different controlled positions. For example, a 3DSM system may comprise one or more of the wavelength/polarization control devices in FIGS. 27A-27C, FIGS. 28A-28C, and FIGS. 29A-29C and one or more of the motion control devices in FIGS. 31A-31C, and FIGS. 32A-32C.

I. Surface Emissivity Properties

[0187] In some implementations, a 3DSM system is configured to obtain surface emissivity properties. During data acquisition, the engineered illumination is switched to an on state to illuminate the surface and then switched to an off state during which the camera receives the emitted light (emissions) from the surface and capture intensity measurements based on the received emissions. These 3DSM systems can be configured to control one or more of motion of the emissive surface, the motion of the engineered illumination and the camera, the wavelength and/or the polarization of the emitted light from the sample surface.

[0188] FIGS. 33-35 are schematic diagrams depicting operations of a data acquisition and analysis phase of a 3DSM method that obtains surface emissivity properties, according to embodiments. FIG. 33 is a schematic diagram illustrating a data acquisition phase performed by a 3DSM system 3300 configured to control the motion of the emissive surface, according to an embodiment. FIG. 34 is a schematic diagram illustrating a data acquisition phase performed by a 3DSM system 3400 configured to control the motion of engineered illumination and a camera, according to an embodiment. FIG. 35 is a schematic diagram illustrating a data acquisition phase performed by a 3DSM system 3500 configured to control the wavelength and/or the polarization of the emitted light from the sample surface, according to an embodiment. In one implementation, the motion control shown in FIG. 33 and FIG. 34 and the wavelength/polarization control shown in FIG. 35 are combined together to capture images at different controlled positions, different wavelength, and different polarization states.

[0189] FIG. 33 is a schematic diagram of operations of a data acquisition phase that controls the motion of an emissive surface 3382 and operations of an analysis phase that obtains surface emissivity properties, as performed by a 3DSM system 3300 of an embodiment. The 3DSM system 3300 comprises a sample platform for receiving a sample 3380 with an emissive surface 3382, an engineered illumination system 3330, a motion control device 3332 coupled to the sample platform 3340, a camera 3360 for capturing images, and one or more processors 3322. When the engineered illumination system 3330 is in the on state, the engineered illumination system 3330 provides engineered illumination to the emissive surface 3382 of the sample 3380. The illustrated example shows the illumination system 3330 in the off state after an on state. At this instant, emissive surface 3381 is emitting light (emissions) that is propagated to the camera 3360. The motion control device 3332 is configured for controls such as translation, tilt, and rotation that can be applied to the emissive surface 3382. At each motion controlled position, images are captured under different exposure settings by the camera 3360. Although two exposures, Exposure A and Exposure B, are shown, additional images can be taken. During operation, the image data of the captured images is communicated in a signal to the one or more processors 3322 and the processor(s) use the image data to measure the surface emissivity properties, such as color, brightness, and uniformity.

[0190] FIG. 34 are diagrams illustrating operations of a data acquisition phase that controls the motion of engineered illumination and camera and operations of an analysis phase that obtain surface emissivity properties, as performed by a 3DSM system 3400 of an embodiment. The 3DSM system 3400 comprises an assembly 3401 that including the engineered illumination system 3430 and the camera 3460 for capturing images. The 3DSM system 3400 further comprises a motion control device 3432 coupled to the assembly 3401, and one or more processors 3422. When the engineered illumination system 3430 is in the on state, the engineered illumination system 3430 provides engineered illumination to the emissive surface 3482 of the sample 3480. The illustrated example shows the illumination system 3430 in the off state after an on state. At this instant, emissive surface 3482 is emitting light (emissions) that is propagated to the camera 3460. The motion control device 3432 is configured for different motion controls such as translation, tilt, and rotation as can be applied to both the engineered illumination and the camera 3460 or to the camera 3460 alone. At each motion controlled position, images are captured under different

exposure settings by the camera **3460**. Although two exposures, Exposure A and Exposure B, are shown, additional images can be taken. During operation, the image data of the captured images is communicated in a signal to the one or more processors and the processor(s) use the image data to measure the surface emissivity properties, such as color, brightness, and uniformity.

[0191] FIG. 35 are diagrams illustrating operations of a data acquisition phase that control the wavelength and/or polarization of emitted light **3598** from an emissive surface **3582** of a sample **3580** and operations of an analysis phase that obtain surface emissivity properties as performed by a 3DSM system **3500**, according to an embodiment. The 3DSM system **3500** comprises an engineered illumination system **3530**, a camera **3560** for capturing images, a wavelength/polarization control device **3538** configured to change the wavelength and/or polarization states of light emitted from the emissive surface **3582** of the sample **3580**, and one or more processors **3522**. When the engineered illumination system **3530** is in the on state, the engineered illumination system **3530** provides engineered illumination to the emissive surface **3582** of the sample **3580**. The illustrated example shows the illumination system **3530** in the off state after an on state. At this instant, the emissive surface **3582** is emitting light (emissions) and the wavelength/polarization control device **3538** is controlling the wavelength and/or polarization state of the emissions and propagates light to the camera **3560**. The wavelength and polarization of emitted light can be controlled alone or be controlled together, and the surface emissivity properties are measured at different wavelength and/or polarization states by the 3DSM system **3500**.

J. Surface Translucency Properties

[0192] In some implementations, a 3DSM system can be configured to obtain surface translucency properties. For example, when the surface of a sample is found to be translucent, the engineered illumination can be switched to an off state. A backlight placed behind the translucent surface is then illuminated, and the camera only measures the transmitted light from the translucent surface. The intensity measurements can be used to determine the surface translucency properties of the sample surface.

[0193] FIG. 36 is a schematic diagram of operations of a data acquisition phase that controls the motion of a translucent surface **3682** and operations of an analysis phase

that obtains surface translucency properties, as performed by a 3DSM system **3600** of an embodiment. The 3DSM system **3600** comprises a backlight source **3690**, a motion control device **3632**, an engineered illumination system **3630**, a camera **3660**, and one or more processors **3622**. The motion control device **3632** is coupled to a sample platform shown having the sample **3680** disposed thereon during operation. The illustrated example shows the engineered illumination system **3630** in an off state. At this instant, the backlight source **3690** located behind the translucent surface **3680** provides backlight **3691**. The camera **3660** only measures transmitted light **3698** through the translucent surface **3680**. The motion control device **3632** controls the motion and position of the translucent surface **3680**. At each of the controlled positions, multiple images are captured under different exposure settings: “Exposure A” and “Exposure B.” Although two exposures are shown, additional exposures may be used in another embodiment. As depicted in **FIG. 36**, the image data of the captured images is communicated in a signal to the one or more processors **3622** and the processor(s) use the image data to measure the surface translucency properties, such as, for example, one or more of color, transmission, and alpha map.

[0194] **FIG. 37** is a schematic diagram of operations of a data acquisition phase that controls the motion of the backlight **3791** as performed by a 3DSM system **3700** of an embodiment. The 3DSM system **3700** comprises a backlight source **3790**, a motion control device **3732**, an engineered illumination system **3730**, a camera **3760**, and one or more processors **3722**. The illustrated example shows the engineered illumination system **3730** in an off state. At this instant, the backlight source **3790** located behind the translucent surface **3780** provides backlight **3791**. The camera **3760** only measures transmitted light **3798** through the translucent surface **3780**. The motion control device **3732** controls the motion of the backlight **3791**. Different motion controls such as, for example, one or more of translation, tilt, and rotation can be applied to backlight **3791**. At each of the controlled positions, multiple images are captured under different exposure settings: “Exposure A” and “Exposure B.” Although two exposures are shown, additional exposures may be used in another embodiment. As depicted in **FIG. 37**, the image data of the captured images is communicated in a signal to the one or more processors **3722** and the processor(s) use the image data to measure the surface translucency properties, such as, for example, one or more of color, transmission, and alpha map.

[0195] FIG. 38 is a schematic diagram of operations of a data acquisition phase that controls the motion of the engineered illumination and the camera 3860 and operations of an analysis phase that obtains surface translucency properties, as performed by a 3DSM system 3800 of an embodiment. The 3DSM system 3800
5 comprises, an assembly 3830 comprising an engineered illumination system 3830 and a camera 3860 for capturing images, a motion control device 3833 coupled to the assembly 3830, and one or more processors 3822. The illustrated example shows the illumination system 3830 in an off state. At this instant, a backlight source 3890 located behind the translucent surface 3880 provides backlight 3891. The camera 3860 only measures transmitted light 3898 through the translucent surface 3880. The motion control device 3833 controls the motion of engineered illumination and camera. Different motion controls such as translation, tilt, and rotation can be applied to both engineered illumination and the camera 3860 or to the camera 3860 alone, and at each controlled position images are captured under different exposures. At each of
10 the controlled positions, multiple images are captured under different exposure settings: "Exposure A" and "Exposure B." Although two exposures are shown, additional exposures may be used in another embodiment. As depicted in FIG. 38, the image data of the captured images is communicated in a signal to the one or more processors 3822 and the processor(s) use the image data to measure the surface translucency properties, such as, for example, one or more of color, transmission, and alpha map.
15
20

[0196] FIG. 39 is a schematic diagram of operations of a data acquisition phase that controls the wavelength and/or polarization of both a backlight 3938 and/or transmitted light from a surface 3982, as performed by a 3DSM system 3900 of an
25 embodiment. The 3DSM system 3900 comprises, a backlight source 3938, a first wavelength/polarization control device 3990, an engineered illumination system 3930, a second wavelength/polarization control device 3939, a camera 3960 for capturing images, and one or more processors 3922. The illustrated example shows the engineered illumination system 3930 in an off state. At this instant, a backlight source 3938 located behind the translucent surface 3980 provides backlight 3992. The camera 3960 only measures transmitted light 3999 through the translucent surface 3980. The first wavelength/polarization control device 3990 controls the wavelength and/or polarization of the backlight 3938 and the second wavelength/polarization control device 3939 controls the wavelength and/or polarization of transmitted light
30

3998 from the surface 3982 of the sample 3980. The wavelength and polarization state can be controlled alone or be controlled together. The backlight and transmitted light can also be controlled individually or be controlled together. At each of the controlled positions, multiple images are captured under different exposure settings:
5 “Exposure A” and “Exposure B.” Although two exposures are shown, additional exposures may be used in another embodiment. As depicted in FIG. 39, the image data of the captured images is communicated in a signal to the one or more processors 3922 and the processor(s) use the image data to measure the surface translucency properties at different wavelength and polarization states.

10 [0197] In one embodiment, the motion control shown in FIGS. 37-38 and the wavelength/polarization control shown in FIG. 39 can also be combined together to capture images at different controlled positions, different wavelength, and different polarization state.

15 *K. An example of a 3DSM System with engineered illumination in the off state*

[0198] FIG. 40 depicts a schematic diagram depicting an implementation of the 3DSM system 900 of FIGS. 11A-B and FIG. 12. In this implementation, the 3DSM system 900 is configured to switch the engineered illumination to an off state. The 3DSM system 900 comprises an engineered illumination system having optical
20 elements including a diffuser 936, a rotating mirror 937, and a beam-splitter 938. The engineered illumination system also includes collimated illumination 935 from an illumination device (not shown). The 3DSM system 900 further comprises a camera 960. The 3DSM system 900 also includes an x-axis, a y-axis, and a z-axis (not shown) orthogonal to the x-axis and the y-axis. The 3DSM system 900 also includes a motion
25 control device 932 coupled to the rotating mirror 937. The motion control device 932 is configured to rotate the mirror 937 about the x-axis and the y-axis (two orthogonal rotational directions). The illustrations show the rotating mirror 937 being rotated along the x-axis between a first position (dotted line) and the current second position (solid line). In FIG. 40, the diffuser 936 receives collimated illumination 935 and the
30 collimated illumination is transmitted through the diffuser 936. The motion control device 932 turns the rotating mirror 937 to a position that does not reflect the light from the diffuser 936 to the beam splitter 938, for example, a position that is parallel to the diffuser 936. In the illustrated example, the mirror 937 is rotated from a first

position to a second position and the beam A2 is reflected back as beam B2 and does not fall on the beam splitter 938. In this example, the object surface 982 does not receive any light from the engineered illumination. By switching engineered illumination to this off state the camera 960 only measures the emitted light and/or transmitted light from the surface 982. The images in this implementation can be used to measure the surface emissivity properties or the surface translucency properties.

V. 3DSM Methods

[0199] FIG. 42 is a flowchart depicting operations of a 3DSM method, according to various implementations. The 3DSM method is implemented by a 3DSM system of various implementations described herein. The 3DSM method generally comprises a data acquisition phase, an analysis phase and an optional display phase. One or more processors (e.g., processor(s) 22) in FIG.2) execute instructions stored in memory (e.g., memory 24 in FIG. 2) to perform one or more operations of the analysis phase and of the optional display phase.

[0200] At operation 4210, the intensity images are acquired for a run of a data acquisition phase. During the data acquisition phase, engineered illumination of one or more ray bundles is directed to N different illumination directions incident a surface of a sample being analyzed. Examples of engineered illumination systems that can be used to generate the engineered illumination are described in sections above. The N different illumination directions are typically based on rotating the bundles in two orthogonal directions. For example, the 3DSM system may rotate the bundles in 20 rotational angles in a first direction and in 20 rotational angles along a second direction orthogonal to the first direction for a combination of four hundred (400) illumination directions. At each illumination direction, n intensity images are captured at different exposure settings by a camera. FIG. 43 is a flowchart of sub-operations of operation 4210.

[0201] At operation 4212, the 3DSM method initializes the counter $i = 1$. At operation 4214, the engineered illumination system provides engineered illumination to the surface of a sample at an illumination direction θ_i . For example, the engineered illumination system may provide one or more ray bundles of illumination beams of varying intensities to the surface at an illumination direction θ_i . Different system configurations for generating the engineered illumination are described in various

examples described in sections above. At each illumination direction, the sensor(s) of a camera capture n intensity images for different exposure settings (operation **4214**). In one case, two (2) intensity images are captured at each illumination direction. In another case, three (3) intensity images are captured at each illumination direction. In another case, more than three (3) intensity images are captured at each illumination direction.

[0202] At operation **4218**, the 3DSM method increments the counter $i = i + 1$. At operation **4220**, the 3DSM method returns to repeat operations **4214**, **4216**, and **4218** until i is greater than N . If i is greater than N at operation **4220**, the 3DSM method preforms optional operations (denoted by dashed line) **4222**, **4224**. If optional operation **4222** is implemented, the wavelength and/or polarization of light is changed to a different state and the method returns to operation **4212** to repeat the operations **4212**, **4214**, **4216**, **4218**, and **4220** to capture intensity images for the new wavelength/polarization state for the N illumination directions. Alternatively, the wavelength/polarization can be changed to different states at each illumination direction Θ_1 after operation **4214**.

[0203] Optional operation **4224** is typically implemented where the surface of a sample is larger than the camera's field-of-view. During this optional operation **4224**, the sample is translated to different positions to repeat the operations **4212**, **4214**, **4216**, **4218** and optionally **4222** to capture intensity images for different portions (e.g., each portion having the area of the camera's field of view) of the sample surface until the entire sample surface is analyzed. In one example, a motion control device (e.g., an x-y stage) is used to translate the sample to different locations incrementally so that the camera has a field-of-view of different portions of the sample surface. In another example, the motion control device can translate the illumination device(s) and/or the camera relative to the sample.

[0204] Returning to **FIG. 42**, at operation **4300**, one or more processors execute instructions that determine a map of surface normals for each based on the intensity images. **FIG. 44** is a flowchart of sub-operations of operation **4300**.

[0205] At operation **4310**, the 3DSM method generates a measured sensor response for each of the sensor pixels based on the intensity images captured during the data acquisition phase. Each sensor pixel corresponds to a surface point of the surface.

During the data acquisition phase, one or more sensors of a camera of the 3DSM system capture intensity values at each sensor pixel for the N different illumination directions and for the different exposure settings and optionally for different wavelength/polarization states. A measured sensor response is constructed for each sensor pixel based on the measured intensity values at the sensor pixel for the N different illumination directions for one of the different exposures. In one case, the 3DSM system determines one of the different exposures to use in the measured sensor response based on the best contrast or dynamic range. In another case, all the measured intensity values under different exposures are converted to a radiance map or a high dynamic range image.

[0206] At operation **4320**, the 3DSM method determine a surface normal for each sensor pixel by matching the measured sensor response to the best fit of a set of pre-determined sensor responses for different surface normals. Because the illumination is engineered with a known distribution, a sensor response can be pre-determined by taking a convolution of the engineered beam distribution function with all the possible surface normal directions at different illumination directions. The measured surface normal can then be determined based on the best matching between captured sensor response and the pre-determined sensor response. A best matched pre-determined sensor response can be found based on different metrics, such as correlation and minimum difference. The surface normal vector of the matched pre-determined sensor response is then assigned to that pixel. The same sensor response matching process is repeated for all the pixels in the captured images to determined surface normals of the surface.

[0207] In one example, the sensor response matching for surface normal estimation can be described using the following Eqn. 1:

$$O(n) = \sum_i [S_i - S'_i]^2 \quad (\text{Eqn. 1})$$

Where n is the surface normal, S_i is the measured sensor response with engineered illumination rotated to the i^{th} direction, and S'_i is the predicted sensor response also with engineered illumination rotated to the i^{th} direction. Other objective functions can also be used. The unknown surface normal n can be estimated based on optimization or using a brute force approach in which the predicted sensor responses are computed

for various surface normal conditions and are compared with measured sensor response at each surface location.

[0208] Returning to FIG. 42, once the surface normals are determined for the entire surface, the 3DSM method estimates a depth map to determine a measured surface topography from the surface normals (operation 4320). A depth map can be calculated from the determined surface normals. This operation can be done based on an objective function that is the integral of the square of the errors between surface gradients of estimated surface depth and measured surface gradients.

[0209] At operation 4340, the 3DSM method determines various surface properties of the sample based on the surface normals. Reflectance properties, such as diffuse albedo, specular albedo and roughness can be estimated based on a BRDF model, such as the Ward model, the Cook-Torrance model and the Blinn-Phong Model.

[0210] The BRDF model is a mathematical approximation of how surfaces react to light, and models the diffuse characteristics and specular highlight of surface material. When light is incident on a surface from different angles, the reflected light represents different BRDF characteristics. Since the engineered illumination is rotated to different orientations, a large number of angular samplings of surface's BRDF are collected. The collected data from the images is fitted into a BRDF mathematical model such as, for example, the Ward model, the Cook-Torrance model, or the Blinn-Phong Model. These BRDF models are generally a non-linear function with illumination normal and camera viewing normal as the variables, and with normal, diffuse reflection, specular reflection, and roughness as the coefficients. Different BRDF models may have different coefficients, such as anisotropic, basecolor, metallic, and glossiness. For example, an isotropic Ward BRDF model can be described as a non-linear function described in Eqn. 2:

$$\rho(\mathbf{LN}, \mathbf{VN}) = f(n, \rho_d, \rho_s, \beta) \quad (\text{Eqn. 2})$$

where \mathbf{LN} is the normal of incident light, \mathbf{VN} is the normal of camera viewing direction, n is the surface normal, ρ_d is the diffuse reflectance coefficient, ρ_s is the specular reflectance coefficient, and β is the roughness coefficient. $f(n, \rho_d, \rho_s, \beta)$ is a non-linear function describing the BRDF model. \mathbf{LN} and \mathbf{VN} are variables which can be known based on system's design configuration or based on calibration. $n, \rho_d, \rho_s,$ and β are coefficients that need to be estimated. The surface normals are estimated at

operation **4300**. The ρ_d , ρ_s , and β coefficients can then be estimated using an objective function as follows:

$$O(\rho_d, \rho_s, \beta) = \sum_i [S_i - (\mathbf{LN} \cdot \mathbf{VN})f(\rho_d, \rho_s, \beta)]^2$$

(Eqn. 3)

5

[0211] Other objective functions can also be used. A brute force approach or non-linear optimization can be applied to estimate the ρ_d , ρ_s , and β coefficients, and this process is repeated for all the surface locations. If desired the estimated surface normal at operation **4300** can also be used as an initial point. The surface normal n can then be refined and ρ_d , ρ_s and β coefficients are estimated using an objective function as below. Other objective functions can also be used in other implementations.

10

$$O(n, \rho_d, \rho_s, \beta) = \sum_i [S_i - (\mathbf{LN} \cdot \mathbf{VN})f(n, \rho_d, \rho_s, \beta)]^2$$

(Eqn. 4)

15

[0212] Optionally (denoted by dashed line), at operation **4360**, the 3DSM method can generate one or more renderings and/or performs additional analyses. Renderings can be generated using techniques such as ray casting or ray tracing based on measured surface normal, depth, reflectance properties, emissivity properties, and translucency properties. During the optional display operation, the renderings and/or other output is provided on a display such as the display **70** shown in **FIG. 2** (operation **4390**).

20

[0213] **FIG. 45** is a block diagram depicting inputs and outputs of the rendering operation **4360**, according to an embodiment. In **FIG. 45**, the illustrates physically-based rendering and photorealistic rendering using measured surface normal, depth, reflectance properties, surface emissivity properties, and surface translucency properties. As shown, the measured surface normal, depth, and reflectance properties such as diffuse reflection, specular reflection, glossiness, base color, metallic map, and roughness can be used to render the reflective appearance of an object. The measured surface emissive properties such as color, brightness, and uniformity can be used to render the emissive appearance of an object. The measured surface translucency properties such as color, transmission, and alpha map can be used to render the translucent appearance of an object.

25

30

[0214] FIGS. 46A-46H are illustrations of surface reflectance properties, surface normal, and depth map of a synthetic leather sample measured by a 3DSM system, according to an implementation. FIG. 46A is a measured diffuse reflection of the synthetic leather surface. FIG. 46B is a measured specular reflection of the synthetic leather surface. FIG. 46C is a measured glossiness of the synthetic leather surface. FIG. 46D is a measured base color that describes the combined color appearance of both diffuse reflection and specular reflection of the synthetic leather surface. FIG. 46E is a measured metallic map that describes the dielectric and metallic properties of the synthetic leather surface. FIG. 46F is a measured roughness of the synthetic leather surface. FIG. 46G is a measured normal map of the synthetic leather surface. FIG. 46H is a measured depth map of the synthetic leather surface. FIG. 46I is a physically-based rendering of the synthetic leather using measured parameters.

- Defect Detection

[0215] In certain implementations, the 3DSM method can detect defects based on certain results determined by a 3DSM method such as described with respect to FIGS. 42-44. FIG. 47 is a block diagram illustrating operations of a 3DSM method that include a defect detection process, according to an embodiment. In FIG. 47, the diagram illustrates surface defect visualization using measured surface normal, depth, reflectance properties, surface emissivity properties, and surface translucency properties. The defects on a reflective surface may present different normal, depth and reflectance properties. Similarly defects on an emissive surface may present different emissivity properties and defects on a translucent surface may present different translucency properties. 3D rendering based on measured reflectance properties, measured emissive properties, and measured translucency properties can be used to provide defect visualization in a three-dimensional space. Different lighting conditions and different viewing conditions can be virtually changed in the 3D rendering.

[0216] FIG. 48 is a block diagram illustrating a defect detection process, according to an embodiment. In FIG. 48, the diagram illustrates surface defect detection and classification using measured surface normal, depth, reflectance properties, surface emissivity properties, and surface translucency properties. Image processing and pattern recognition techniques can be applied to the normal, depth and reflectance properties measured on a reflective surface, be applied to the emissivity properties

measured on an emissive surface, and be applied to the translucency properties measured on a translucent surface. Any defect that presents different appearance on these measured parameters can be detected. The detected defects can then be passed to a machine learning module. Based on a surface defect library that has learned possible defect features surface defects can be classified into different categories.

[0217] FIGS. 49A-49F are illustrations of measured surface reflectance properties, normal, and depth of a LCD panel that is contaminated with dirt and fiber as measured by a 3DSM system, according to an implementation. FIG. 49A is an illustration of measured specular reflection. FIG. 49B is an illustration of measured diffuse reflection. FIG. 49C is an illustration of measured roughness. FIG. 49D is an illustration of a measured normal map. FIG. 49E is an illustration of a measured depth map. The dirt and fiber's reflection is more diffusive than the LCD panel's reflection, and therefore dirt and fiber are showing as darker in the specular map in FIG. 49A, but are much brighter in the diffuse map in FIG. 49B. It can also be seen that dirt and fiber show much larger roughness values in roughness map. In the normal map and depth map it can be seen that dirt and fiber have distinguished values, which indicate different height and 3D shape. All these measured parameters can be used to identify the dirt and fiber defects on the LCD panel. FIG. 49F is an illustration of surface defect visualization using measured parameters. The measured normal, depth, and reflectance properties are used in the 3D rendering. A virtual light is placed in the scene and a camera is virtually placed at an oblique angle. The defects can be clearly visualized in the 3D rendering shown in FIG. 49F.

[0218] FIGS. 50A-50F are illustrations of measured surface reflectance properties, normal, and depth of a LCD panel with scratches and pits as measured by a 3DSM system, according to an implementation. FIG. 50A is an illustration of measured specular reflection. FIG. 50B is an illustration of measured diffuse reflection. FIG. 50C is an illustration of measured roughness. FIG. 50D is an illustration of measured normal map. FIG. 50E is an illustration of a measured depth map. FIG. 50F is an illustration of surface defect detection using measured parameters. The pixels in red are detected defects.

[0219] FIGS. 51-52 are illustrations depicting a surface defect detection process using measured surface emissive properties of a LCD panel that has white spot and a LCD panel that has a non-uniformity as measured by a 3DSM system, according to an

implementation. The images were measured by switching the engineered illumination to an off state. **FIG. 51** is a measured brightness map of a LCD panel that is with white spot, which is identified within the circle. **FIG. 52** is a measured uniformity map of a LCD panel that is not uniform. A non-uniform region is identified within the ellipse.

[0220] In one embodiment, a 3DSM method uses a calibration process by using a mirror and a chrome sphere to compensate for imperfect system alignment and provide more accurate illumination direction information.

[0221] In one embodiment, addition multiple illuminations can be added at oblique angles to improve the estimation.

[0222] In one embodiment, system alignment can be performed by using a mirror as a reference object.

[0223] In one embodiment, wavelength and polarization control can be applied to the engineered illumination and reflected light from object surface.

[0224] In one embodiment, motion control can be applied to the object surface, engineered illumination and camera.

[0225] In one embodiment, the emissivity properties of a emissive surface can be measured by switching the engineered illumination to an off state.

[0226] In one embodiment, the translucency properties of a translucent surface can be measured by switching the engineered illumination to an off state and by placing a backlight behind the surface.

[0227] In one embodiment, measured surface normal, depth, reflectance properties, surface emissivity properties, and surface translucency properties can be used for physically-based rendering and photorealistic rendering.

[0228] In one embodiment, measured surface normal, depth, reflectance properties, surface emissivity properties, and surface translucency properties can be used for surface defect visualization, surface defect detection and classification.

[0229] Modifications, additions, or omissions may be made to any of the above-described embodiments without departing from the scope of the disclosure. Any of the embodiments described above may include more, fewer, or other features without

departing from the scope of the disclosure. Additionally, the steps of the described features may be performed in any suitable order without departing from the scope of the disclosure.

[0230] It should be understood that the present invention as described above can be implemented in the form of control logic using computer software in a modular or integrated manner. Based on the disclosure and teachings provided herein, a person of ordinary skill in the art will know and appreciate other ways and/or methods to implement the present invention using hardware and a combination of hardware and software.

[0231] Any of the software components or functions described in this application, may be implemented as software code to be executed by a processor using any suitable computer language such as, for example, Java, C++ or Perl using, for example, conventional or object-oriented techniques. The software code may be stored as a series of instructions, or commands on a CRM such as a random access memory (RAM), a read only memory (ROM), a magnetic medium such as a hard-drive or a floppy disk, or an optical medium such as a CD-ROM. Any such CRM may reside on or within a single computational apparatus, and may be present on or within different computational apparatuses within a system or network.

[0232] Although the foregoing disclosed embodiments have been described in some detail to facilitate understanding, the described embodiments are to be considered illustrative and not limiting. It will be apparent to one of ordinary skill in the art that certain changes and modifications can be practiced within the scope of the appended claims.

[0233] One or more features from any embodiment may be combined with one or more features of any other embodiment without departing from the scope of the disclosure. Further, modifications, additions, or omissions may be made to any embodiment without departing from the scope of the disclosure. The components of any embodiment may be integrated or separated according to particular needs without departing from the scope of the disclosure.

CLAIMS

WHAT IS CLAIMED IS:

1. A 3D surface measurement system comprising:
 - an engineered illumination system configured to provide at least one ray
 - 5 bundle to N illumination directions incident a surface of a sample being imaged, wherein each ray bundle comprises illumination beams of various intensities;
 - a first camera with an imaging lens and at least one sensor configured to capture intensity images at the N illumination directions based on light received from the illuminated sample; and
 - 10 a controller configured to execute instructions to:
 - determine a sensor response at each sensor pixel from the intensity images at the N illumination directions; and
 - match the sensor response at each sensor pixel to one of a plurality of predetermined sensor responses to determine a surface normal at each sensor pixel;
 - 15 and
 - construct a map of surface normals of the surface by combining the determined surface normal of all the sensor pixels of the at least one sensor.
2. The 3D surface measurement system of claim 1, wherein the
- 20 engineered illumination system comprises:
 - an illumination device with at least one light source; and
 - one or more optical elements configured to generate and propagate the at least one ray bundle based on light from the at least one light source to the surface of the sample and to propagate light from the illuminated surface to the camera.
 - 25
3. The 3D surface measurement system of claim 2, wherein the one or more optical elements comprise a diffuser configured to spread illumination from the at least one light source to the illumination beams of various intensities of each ray bundle according to a transmission profile of the diffuser.
- 30 4. The 3D surface measurement system of claim 3, wherein the diffuser transmission profile is configured to spread the illumination beams of various intensities to different angles according to a Gaussian or Gaussian-like distribution.

5. The 3D surface measurement system of claim 2, wherein the one or more optical elements are further configured to distribute the illumination beams of various intensities at different angles according to a linear gradient.
- 5 6. The 3D surface measurement system of claim 2, wherein the one or more optical elements are further configured to distribute the illumination beams of various intensities at different angles according to a random distribution.
7. The 3D surface measurement system of claim 2, further comprising an
10 additional illumination source configured to direct illumination incident the surface of the sample at an oblique angle
8. The 3D surface measurement system of claim 2, wherein the one or more optical elements comprise:
15 a mirror configured to receive illumination beams propagated from the at least one light source; and
a beam splitter configured to receive the illumination beams from the mirror and reflecting the illumination beams to the surface of the sample and configured to transmit light reflected from the surface of the sample.
20
9. The 3D surface measurement system of claim 2, wherein the one or more optical elements comprise:
a combination filter of a plurality of neutral density filters, the combination filter configured to engineer illumination from the at least one light source into the
25 illumination beams of different intensities, each neutral density filter associated with one illumination beam; and
a collimator configured to collimate the illumination beams propagated from the combination filter.
- 30 10. The 3D surface measurement system of claim 1, wherein the engineered illumination system comprises:
an illumination array having a plurality of illumination elements, the illumination array configured to activate one of the illumination elements at a single exposure time; and

a collimator configured to collimate illumination received from the one activated illumination element; and

a diffuser configured to spread the collimated illumination from the collimator to the illumination beams of various intensities of each ray bundle according to a transmission profile of the diffuser.

11. The 3D surface measurement system of claim 1, further comprising a motion control device configured to manipulate the sample and/or the engineered illumination and the camera together.

10

12. The 3D surface measurement system of claim 11, wherein the motion control device is configured to manipulate the sample and/or the engineered illumination and the camera together to shift the illumination beams to different regions of the surface of the sample.

15

13. The 3D surface measurement system of claim 11, wherein the motion control device is configured to manipulate the sample and/or the engineered illumination and the camera together to direct the illumination beams in the N illumination directions.

20

14. The 3D surface measurement system of claim 2, further comprising a wavelength and/or polarization control device configured to alter the wavelength and/or polarization of the one or more ray bundles or alter the wavelength and/or polarization of reflected light from the surface of the sample.

25

15. The 3D surface measurement system of claim 2, further comprising a first wavelength and/or polarization control device configured to alter the wavelength and/or polarization of the one or more ray bundles and a second wavelength and/or polarization control device configured to alter the wavelength and/or polarization of the reflected light from the surface of the sample.

30

16. The 3D surface measurement system of claim 2, wherein the controller further configured to execute instructions to determine a depth map and/or surface properties of the surface of the sample.

17. The 3D surface measurement system of claim 2, further comprising a second camera with an imaging lens and at least one sensor, the second camera configured to capture intensity images at the N illumination directions based on light
5 received from the illuminated sample, wherein the second camera captures intensity images from a different angle than the first camera.

18. A 3D surface measurement method comprising:
receiving a plurality of intensity images of a sample in a signal from at least
10 one sensor of a camera, the plurality of intensity images captured at a plurality of exposure times at each illumination direction of N illumination directions of one or more ray bundles, each ray bundle comprising illumination beams of various intensities;
determining a sensor response at each sensor pixel from the intensity images at
15 the N illumination directions;
matching a sensor response at each sensor pixel to one of a plurality of predetermined sensor responses to determine a surface normal at each sensor pixel;
and
construct a map of surface normals by combining the determined surface
20 normal of all the sensor pixels of the at least one sensors.

19. The 3D surface measurement method of claim 18, further comprising measuring a depth map of the surface from the map of surface normals.

25 20. The 3D surface measurement method of claim 18, further comprising measuring a map of surface properties of the surface based on the map of surface normals.

21. The 3D surface measurement method of claim 20, wherein the surface
30 properties is one or more of a reflectance property, an emissivity property, and a translucency property.

22. The 3D surface measurement method of claim 20, further comprising determining a defect in the surface of the sample using the one or more of measured surface normal, depth, and surface properties.
- 5 23. The 3D surface measurement method of claim 18, further comprising:
measuring a depth map of the surface from the map of surface normals;
measuring surface properties of the surface based on the map of surface
normals; and
generating a physically-based rendering based on the map of surface normals,
10 the depth map, and the map of surface properties of the surface.
24. A 3D surface measurement method comprising:
a) engineering at least one ray bundle to N illumination directions incident a
surface a sample being imaged, each ray bundle comprising illumination beams of
15 various intensities;
b) capturing, using at least one sensor of a camera, intensity images at a
plurality of exposure times at each illumination direction based on light from the
illuminated sample; and
c) communicating the intensity images to one or more processors, wherein the
20 processors determine a sensor response at each sensor pixel from the intensity images
at the N illumination directions, match a sensor response at each sensor pixel to one of
a plurality of predetermined sensor responses to determine a surface normal at each
sensor pixel, and construct a map of surface normals by combining the determined
surface normal of all the sensor pixels of the at least one sensor.
25
25. The 3D surface measurement method of claim 24, changing
wavelength or polarization of the illumination beams of the one or more ray bundles
and/or light from the illuminated sample, and then repeating a) and b).
- 30 26. A 3D surface measurement method comprising:
engineering at least one ray bundle to N illumination directions incident a
surface of a mirror or a chrome sphere, each ray bundle comprising illumination
beams of various intensities;

capturing, using at least one sensor of a camera, intensity images at each illumination direction based on light reflected from the mirror or the chrome sphere; and

- determining a calibration offset, system misalignment, or illumination
- 5 directions based on the intensity images.

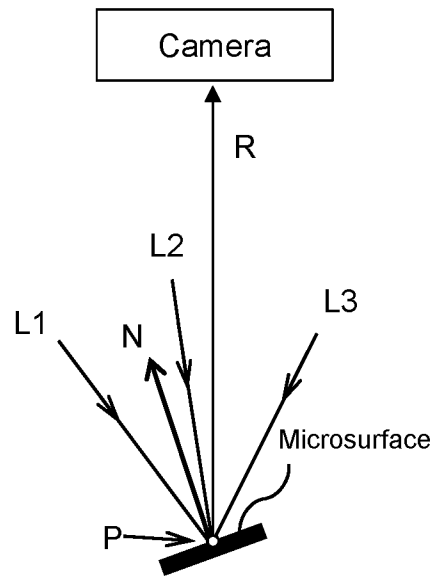

FIG. 1A

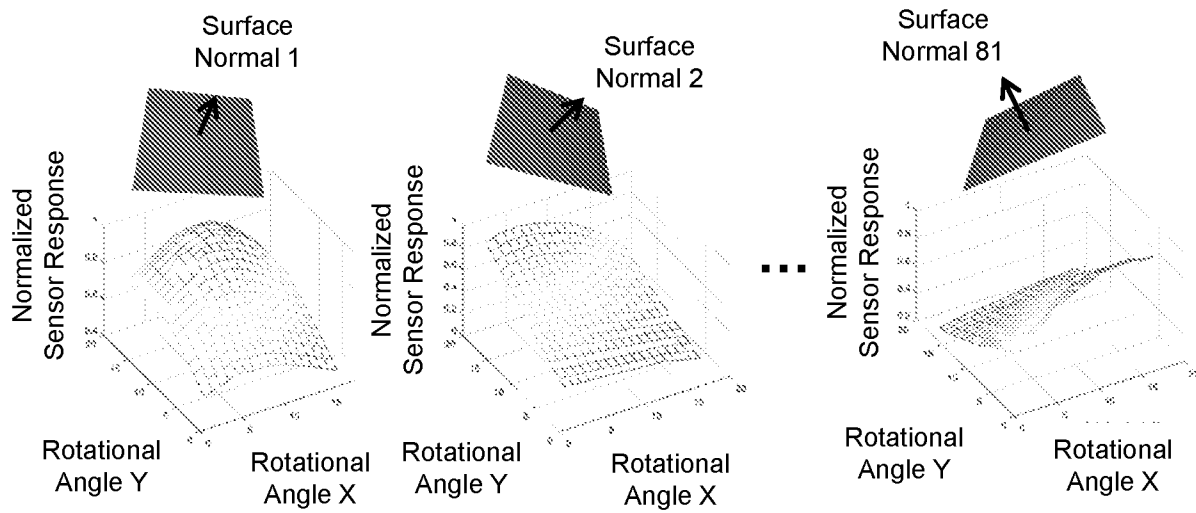

FIG. 1B

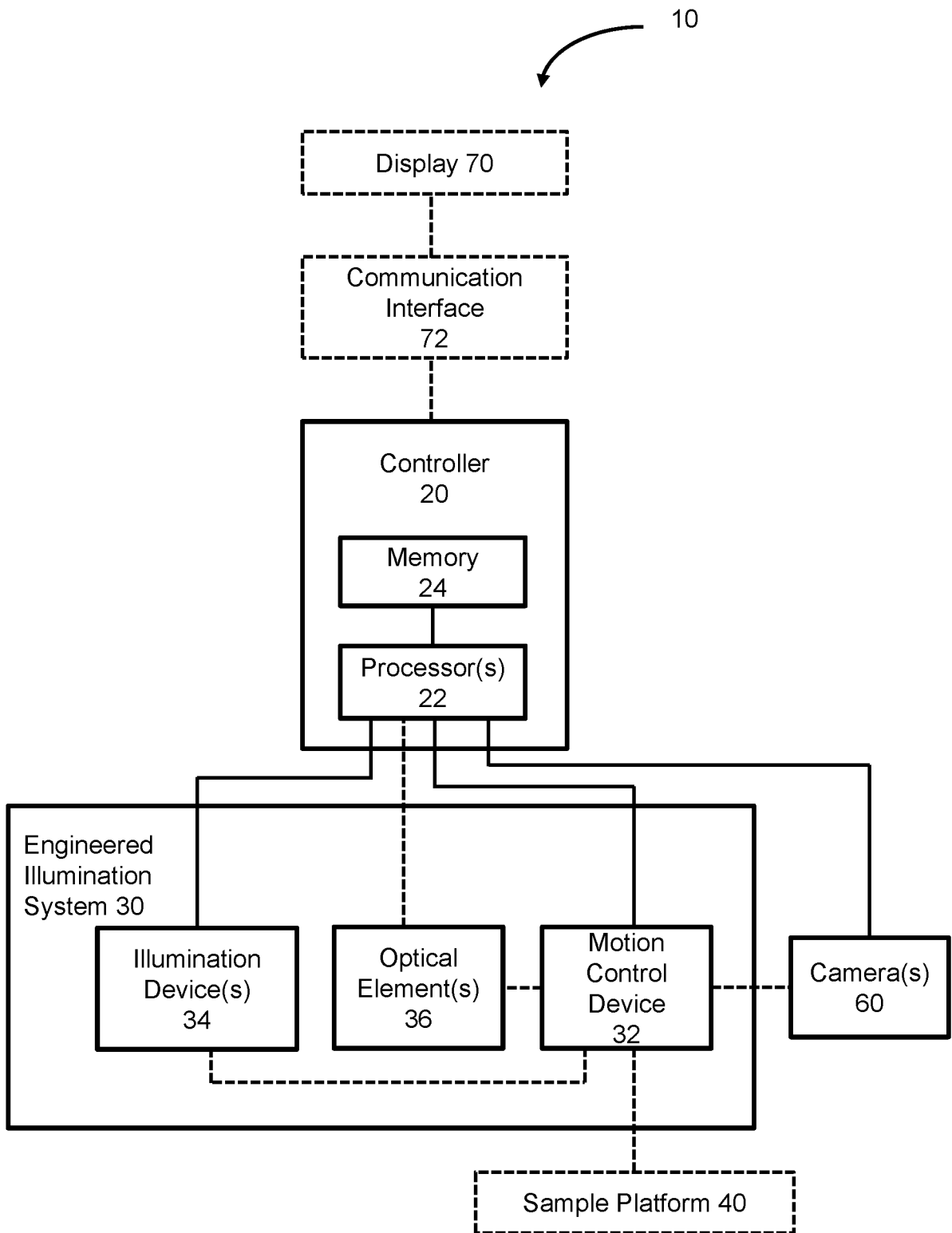

FIG. 2

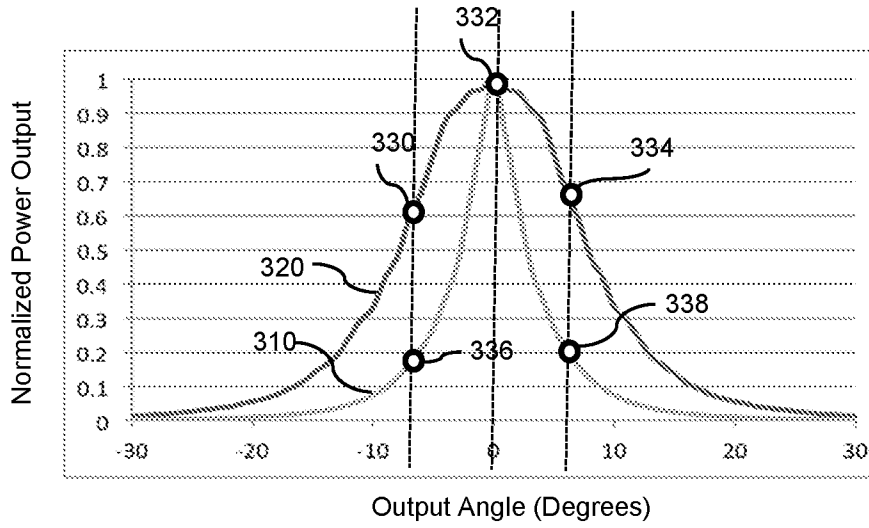

FIG. 3A

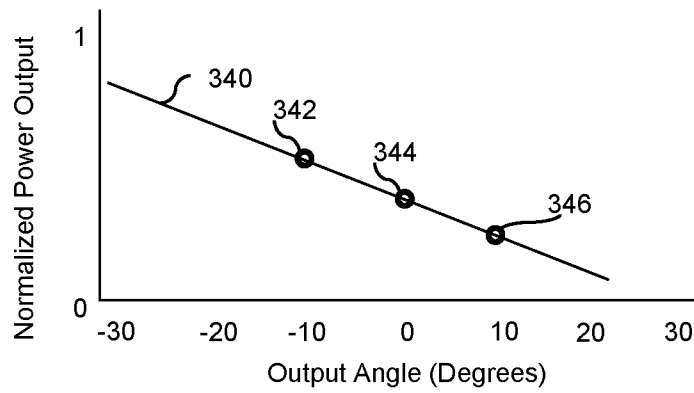

FIG. 3B

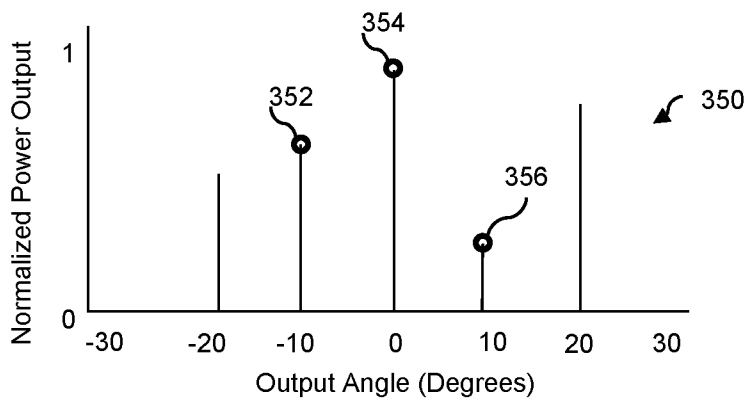

FIG. 3C

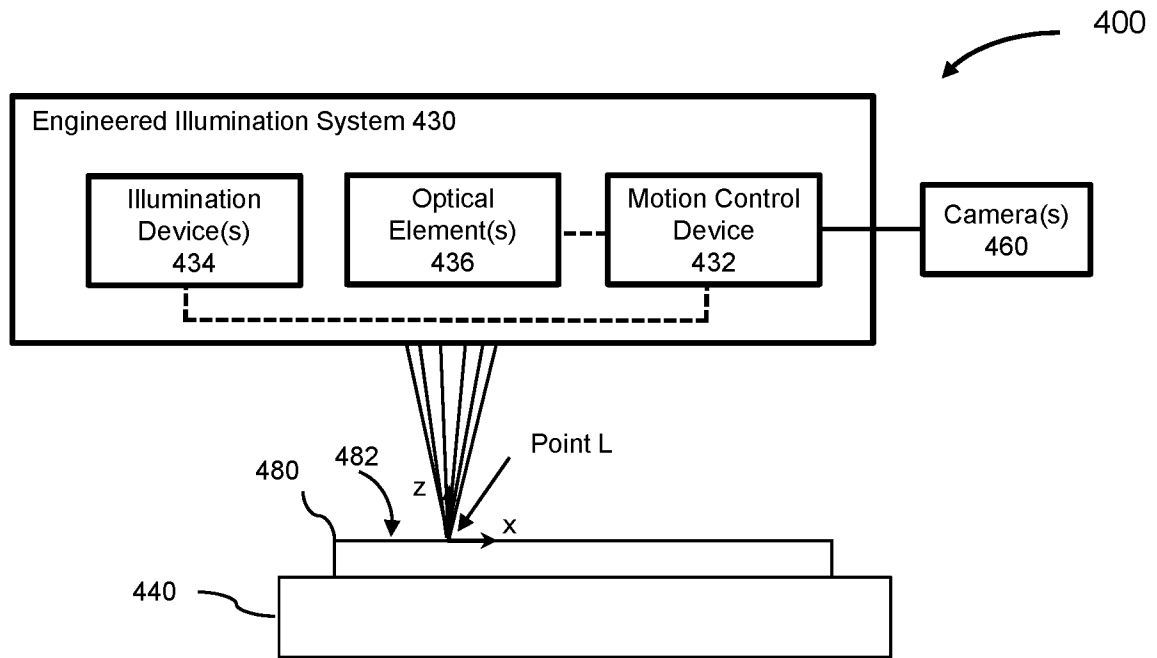

FIG. 4

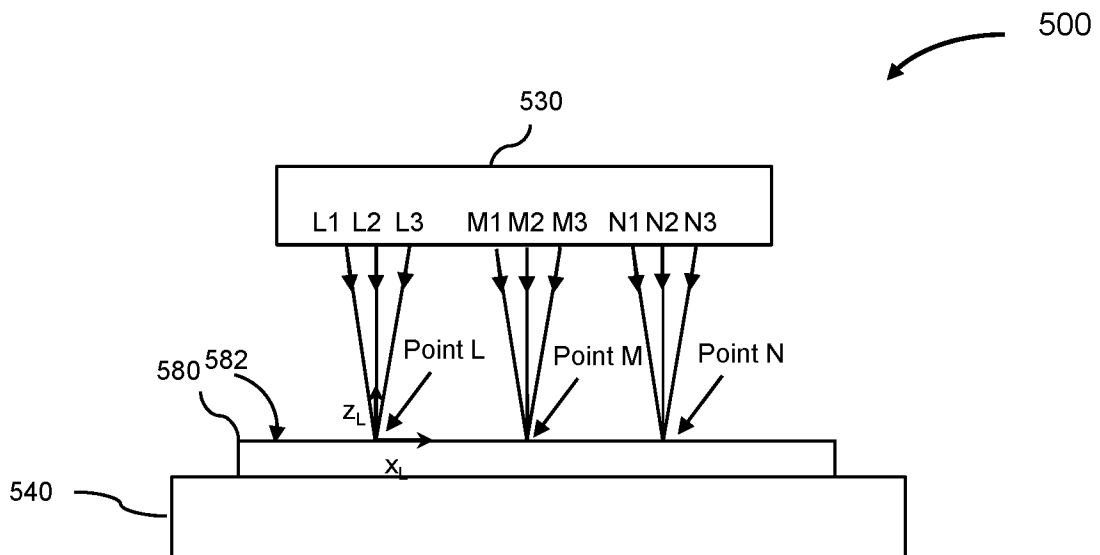

FIG. 5

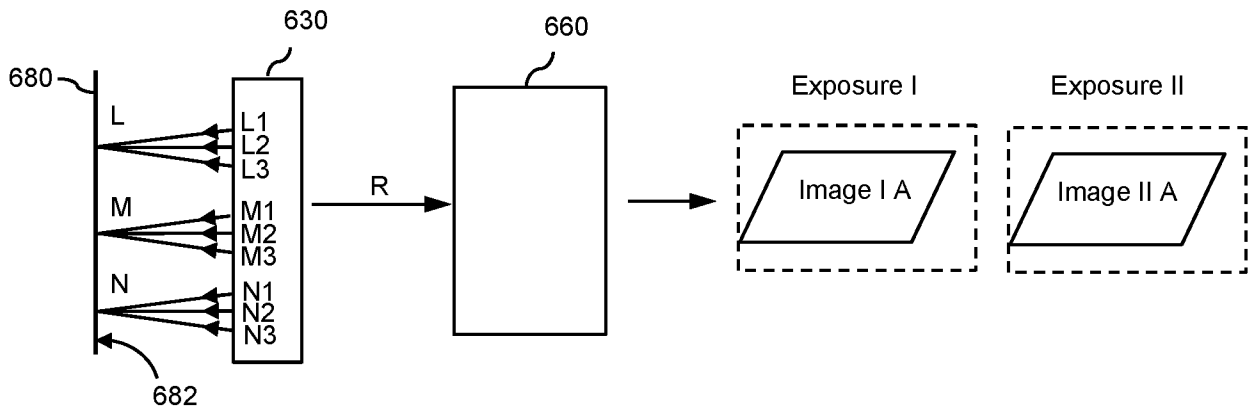

FIG. 6A

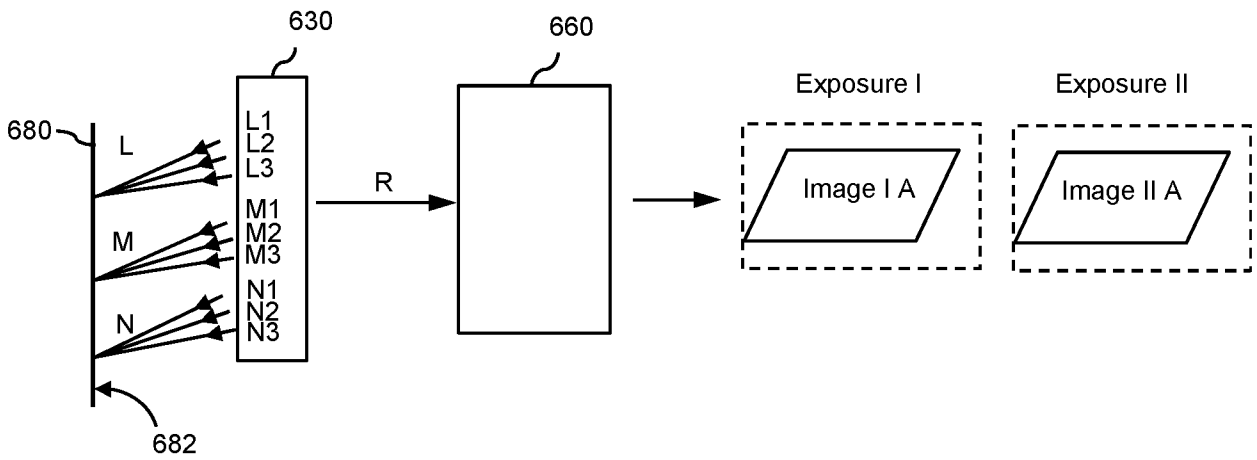

FIG. 6B

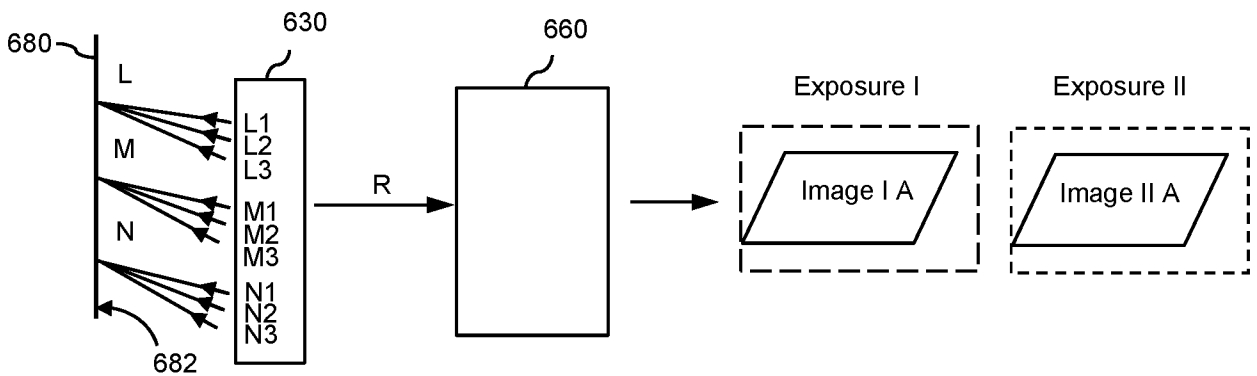

FIG. 6C

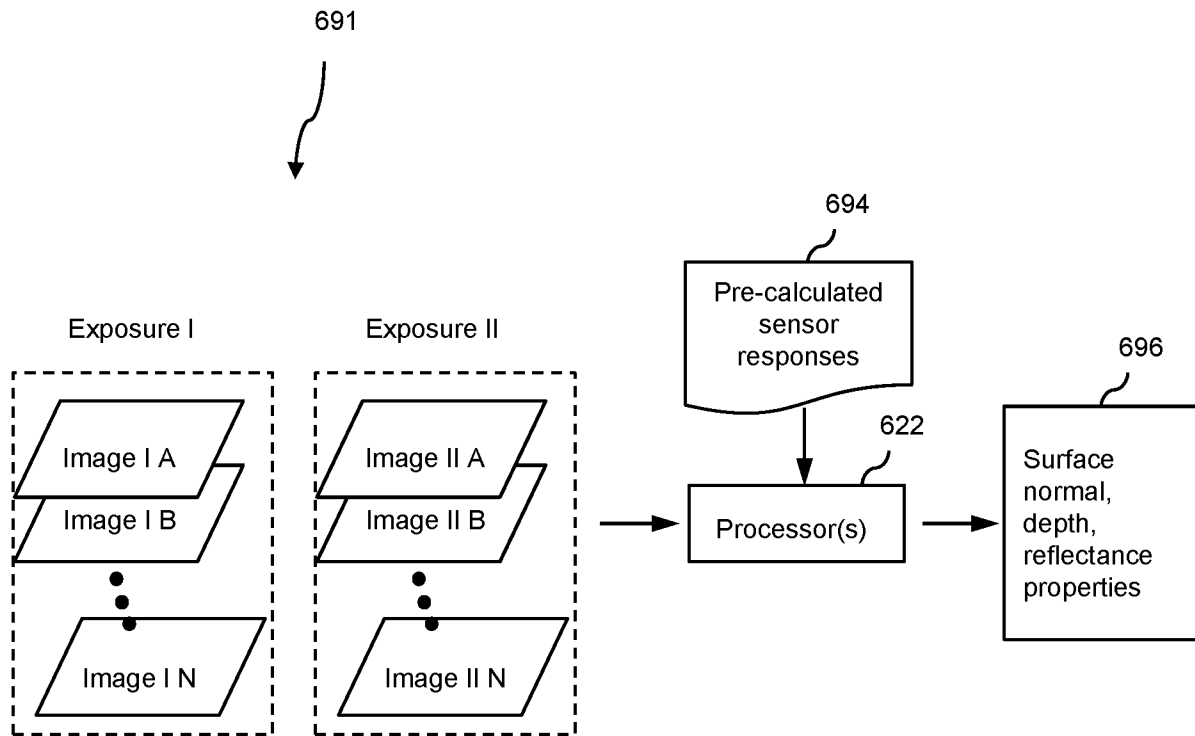

FIG. 6D

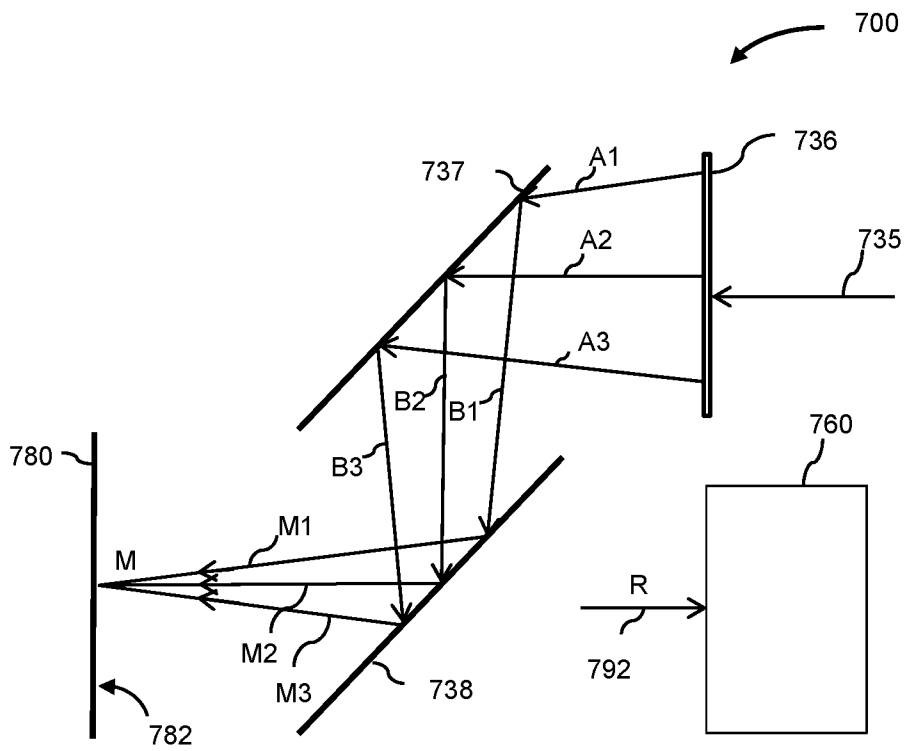

FIG. 7

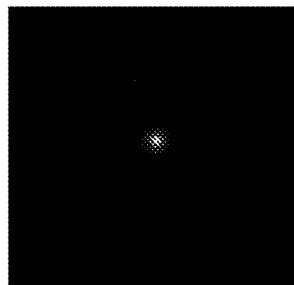

FIG. 8

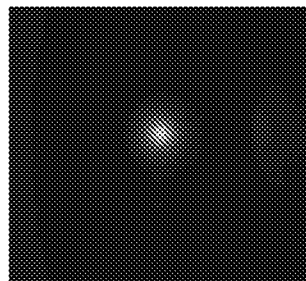

FIG. 9

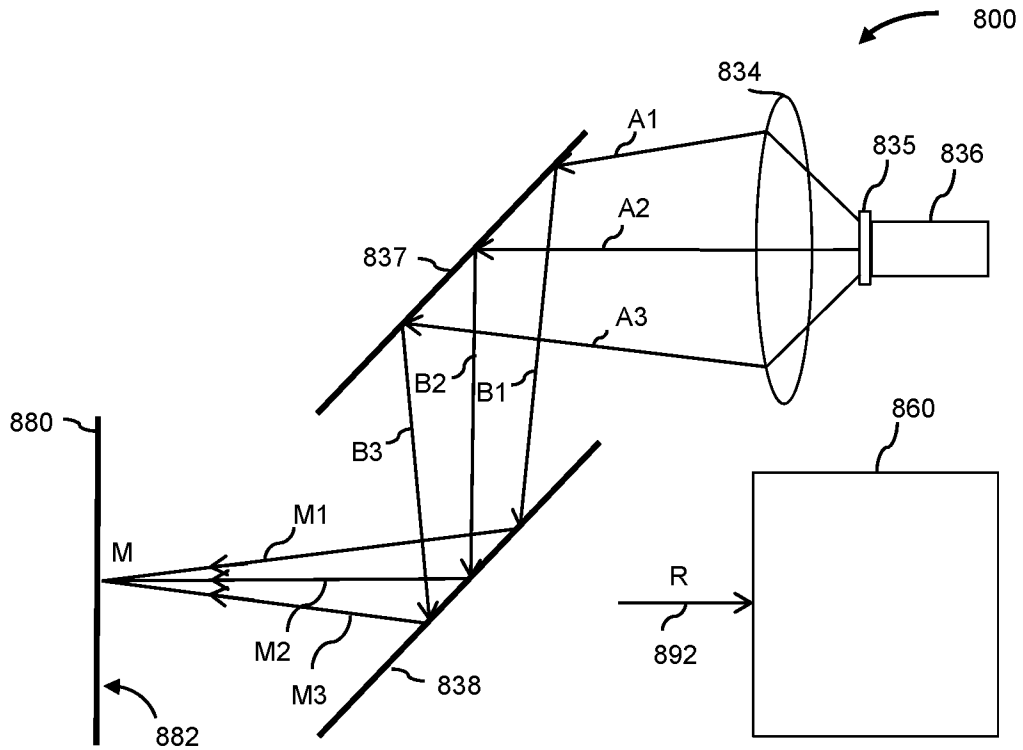

FIG. 10A

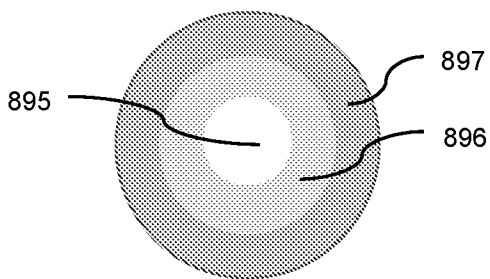

FIG. 10B

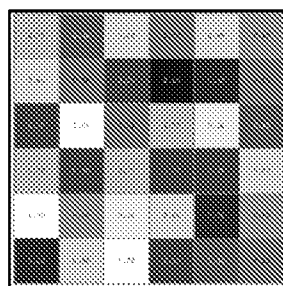

FIG. 10C

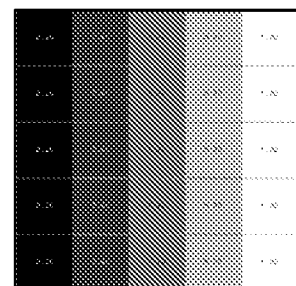

FIG. 10D

FIG. 11A

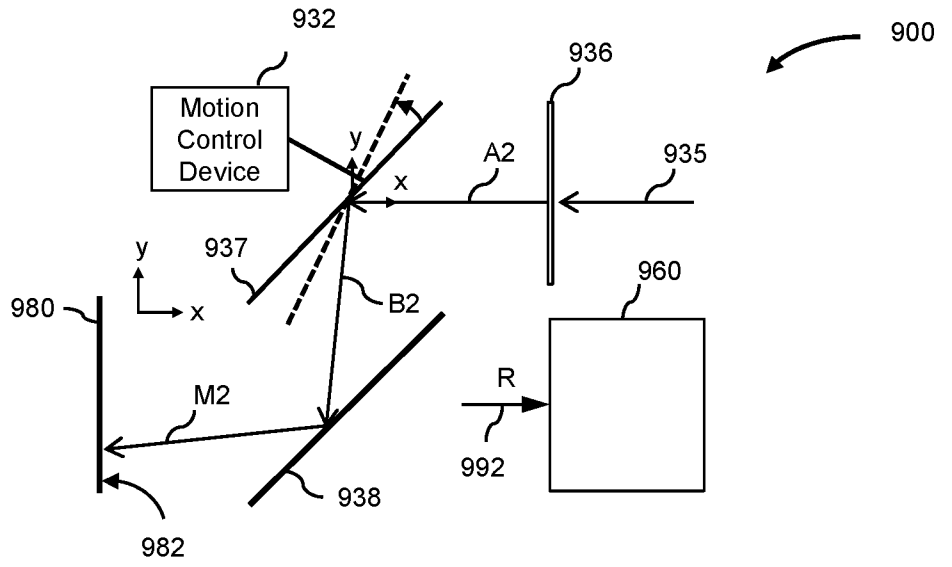

FIG. 11B

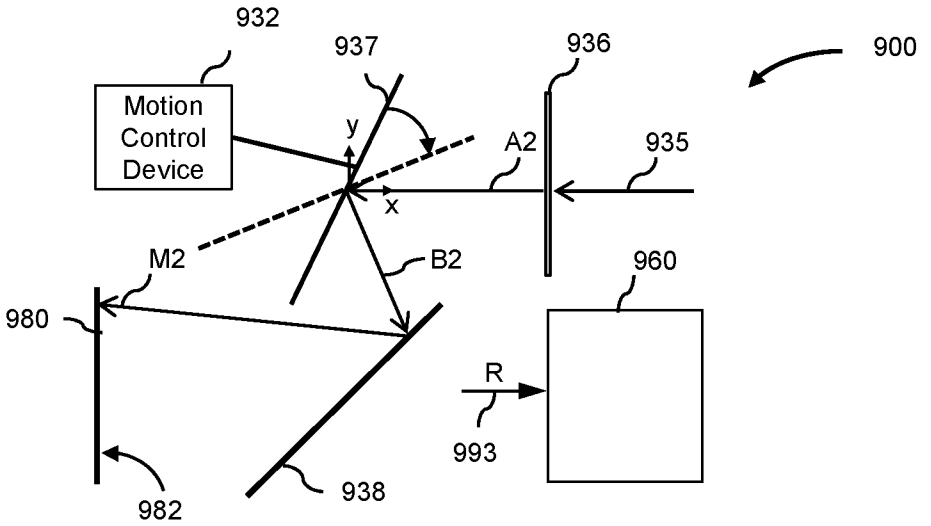
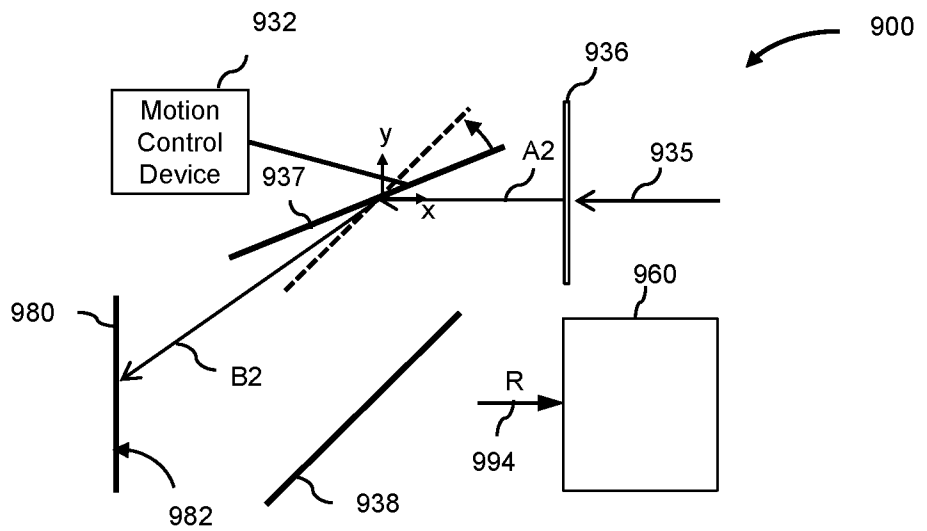

FIG. 12



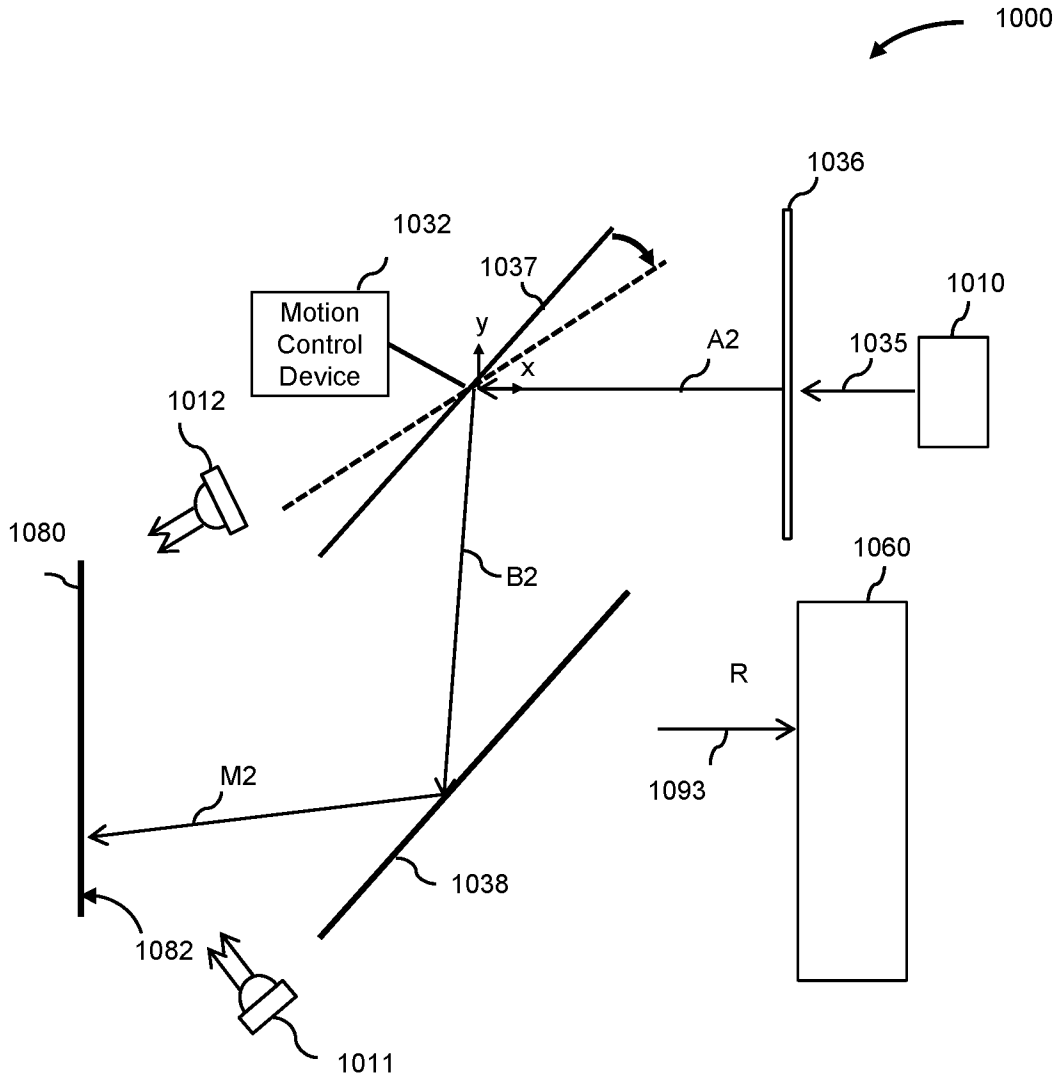

FIG. 13

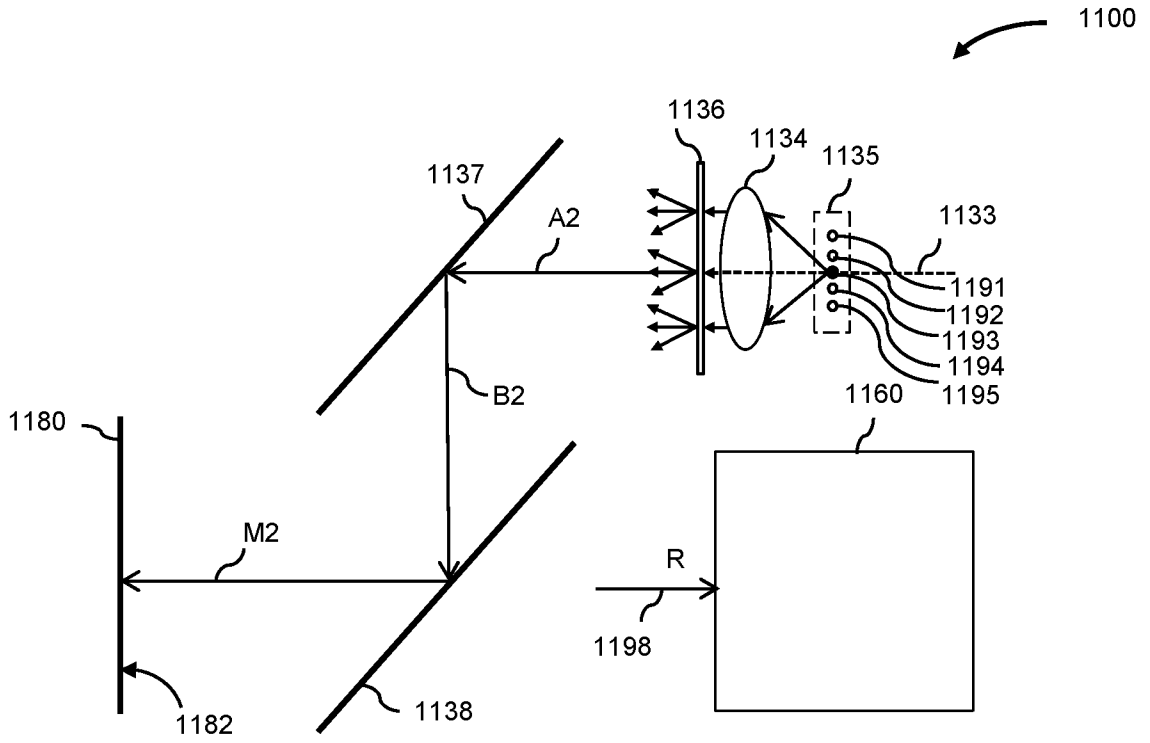

FIG. 14A

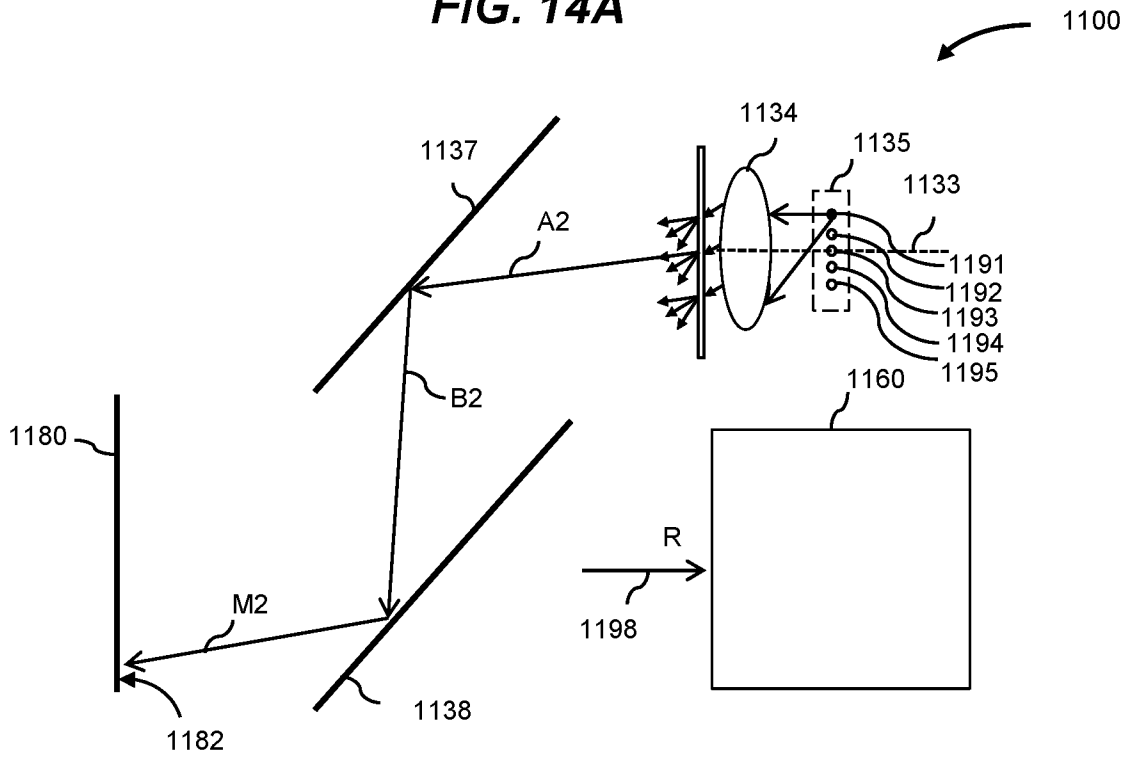

FIG. 14B

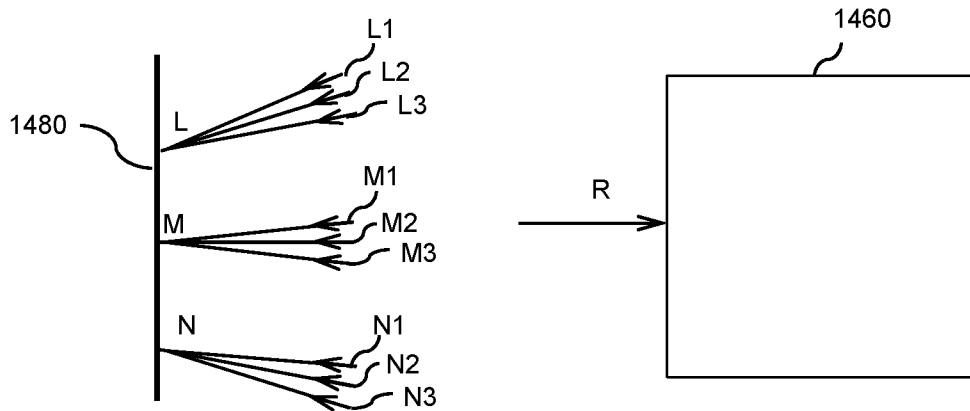

FIG. 15A

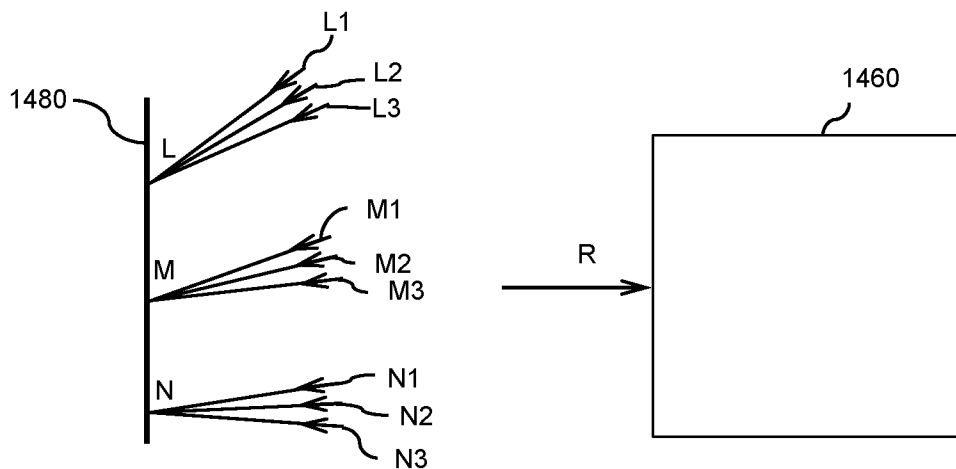

FIG. 15B

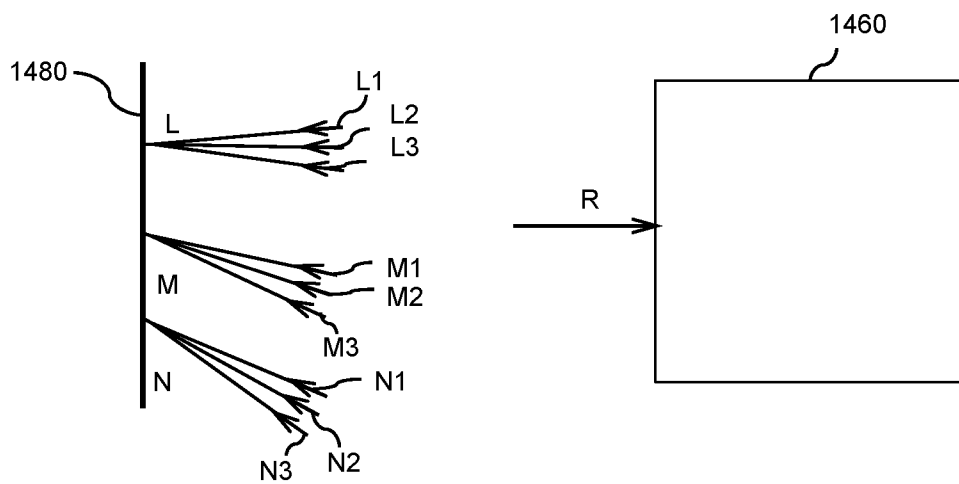

FIG. 15C

FIG. 16A

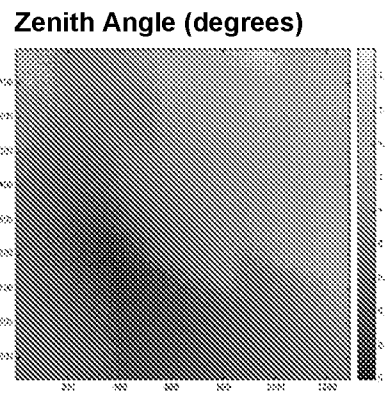

FIG. 16B

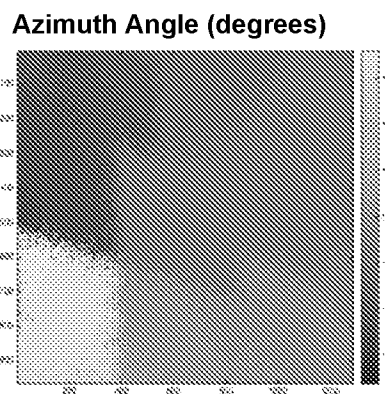

FIG. 17A

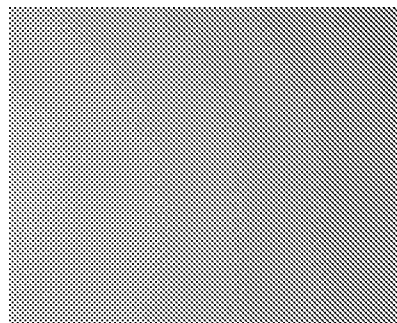
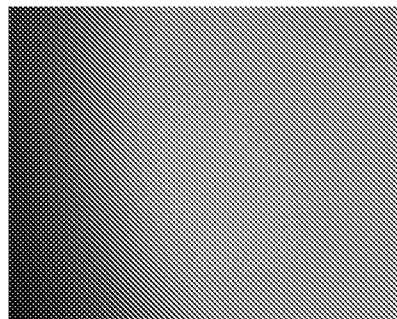

FIG. 17B



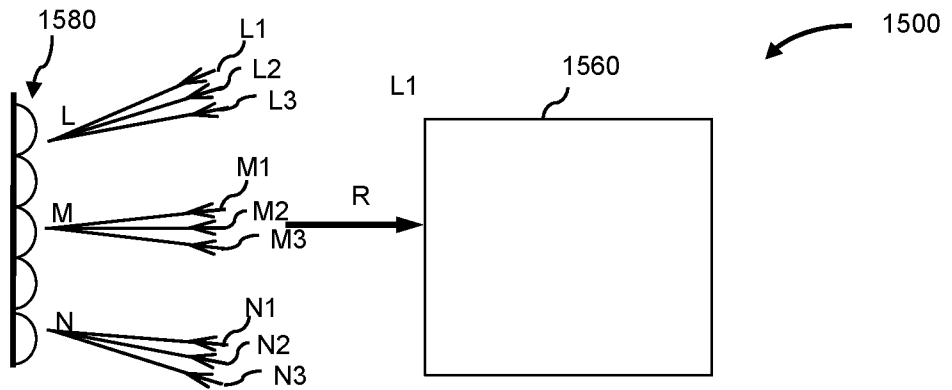

FIG. 18A

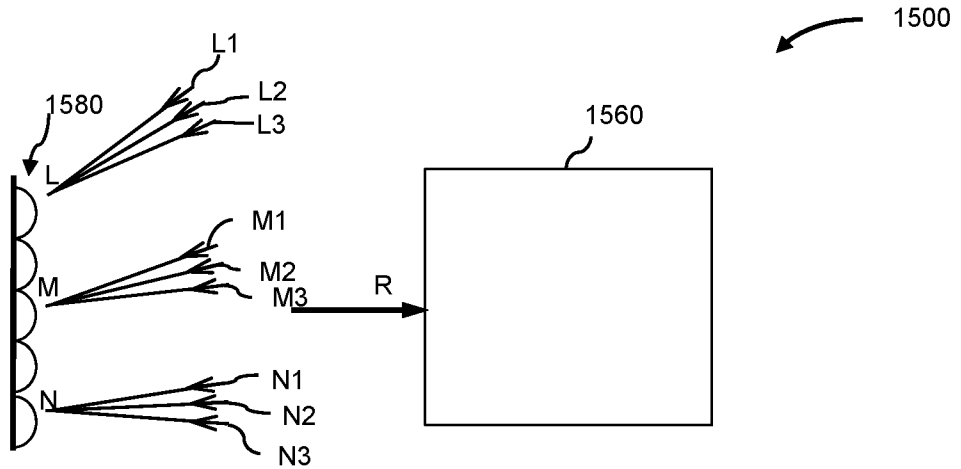

FIG. 18B

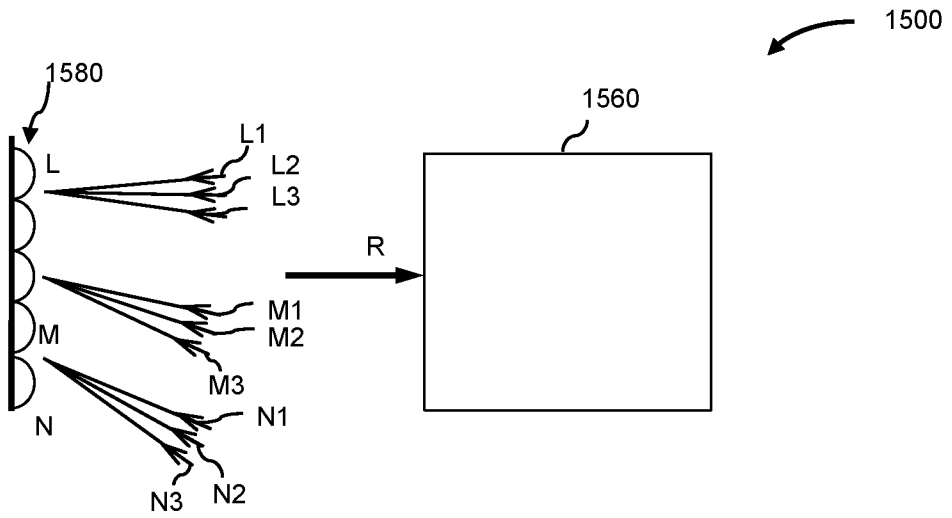

FIG. 18C

FIG. 19A

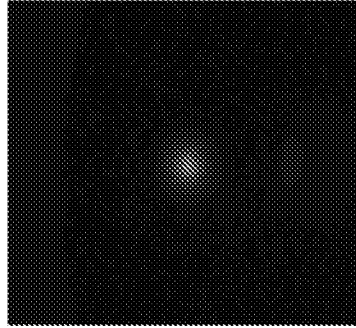

FIG. 19B

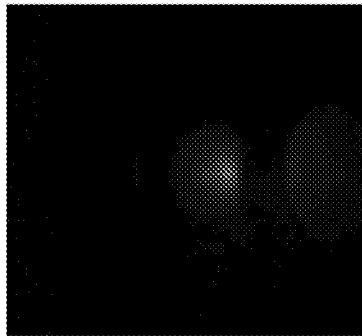

FIG. 20A

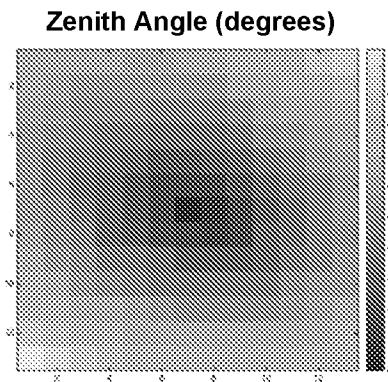
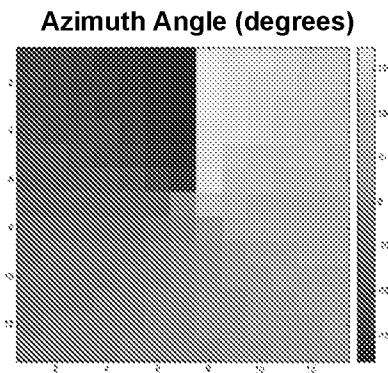

FIG. 20B



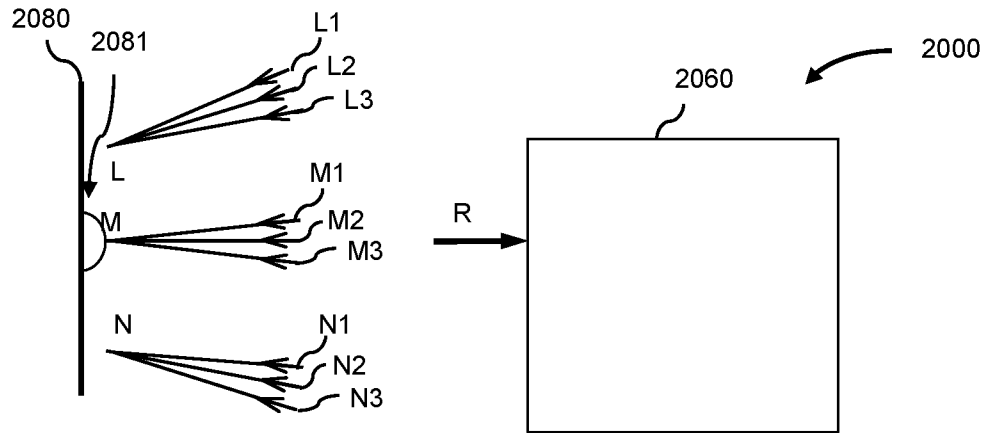

FIG. 21A

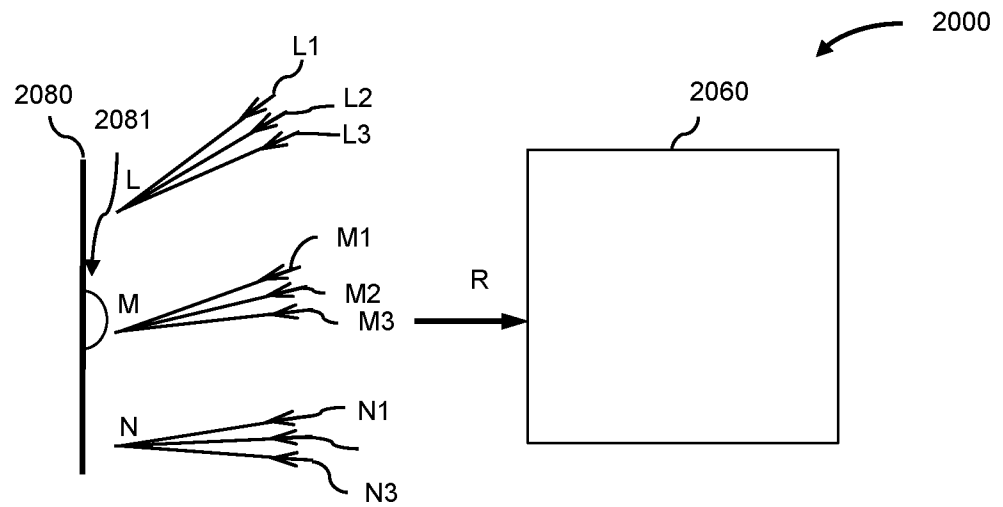

FIG. 21B

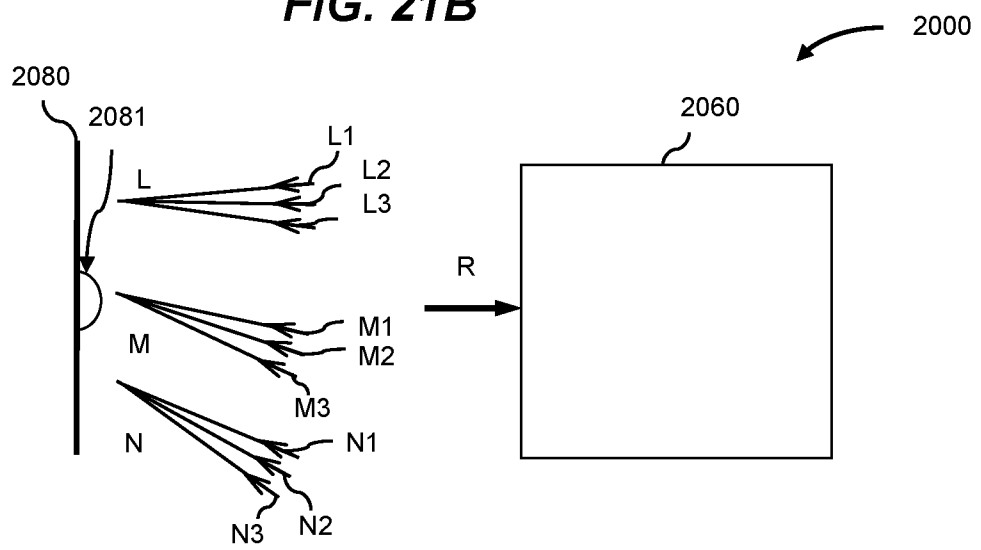

FIG. 21C

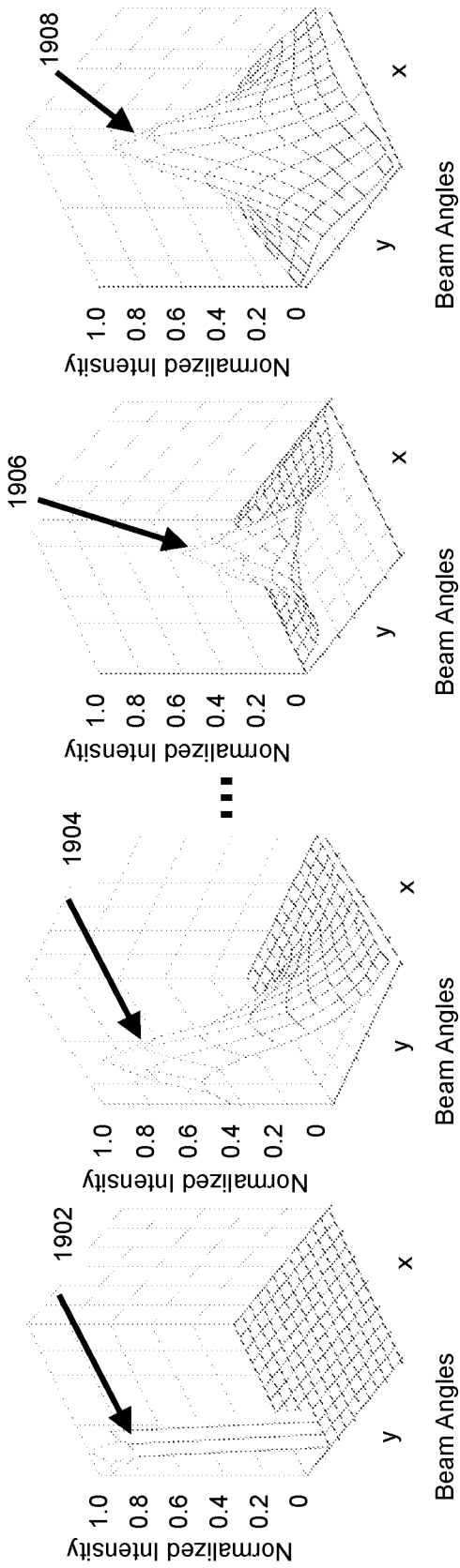

FIG. 22

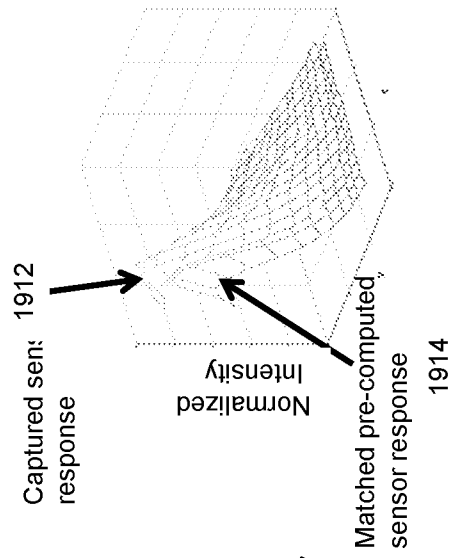
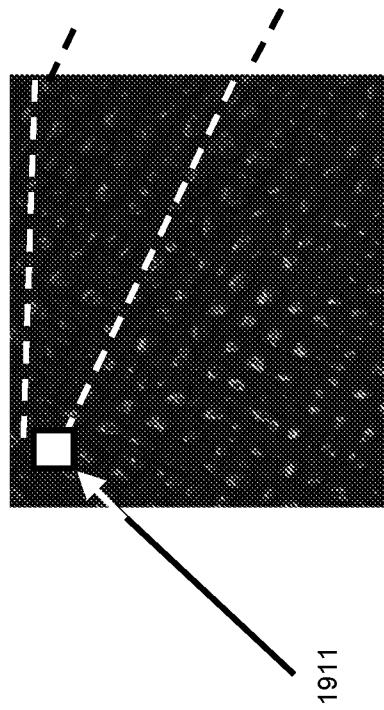

FIG. 23



1911

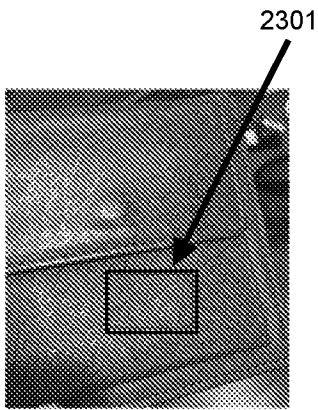

FIG. 24A

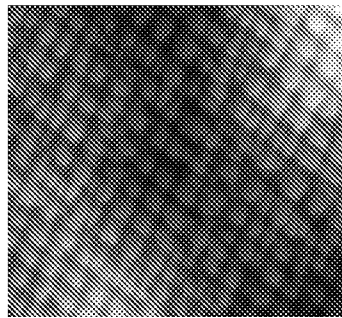

FIG. 24B

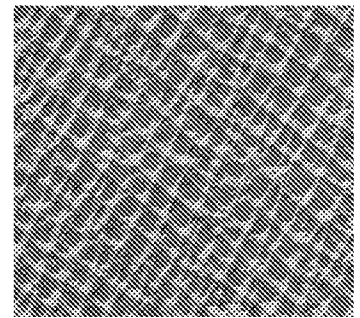

FIG. 24C

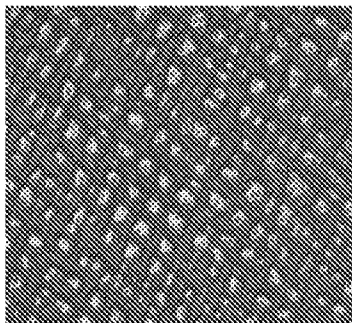

FIG. 24D

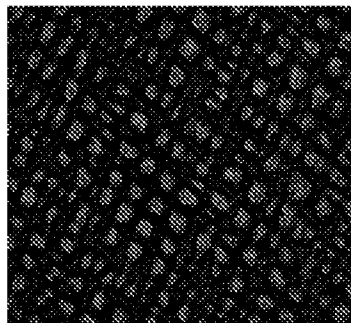

FIG. 24E

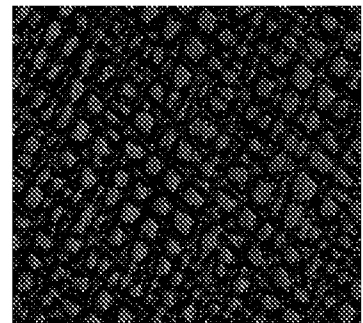

FIG. 24F



FIG. 25A

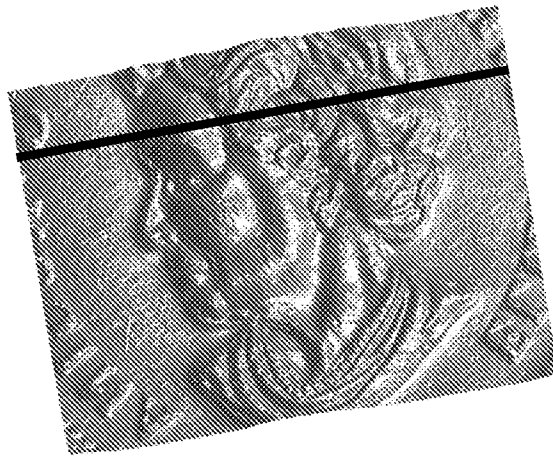

FIG. 25B

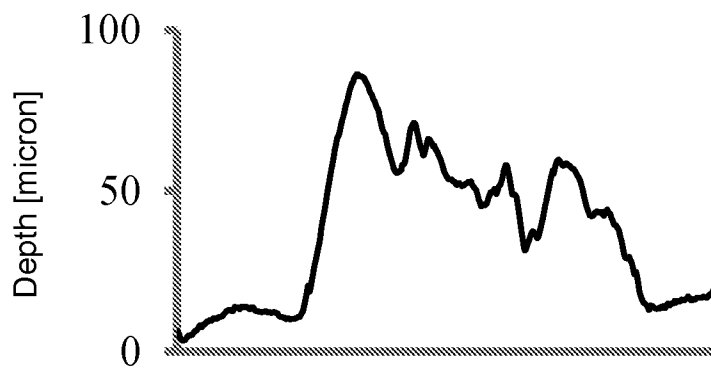

FIG. 25C

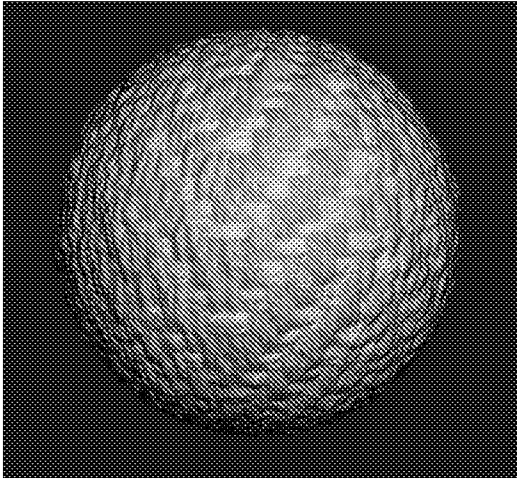

FIG. 26A

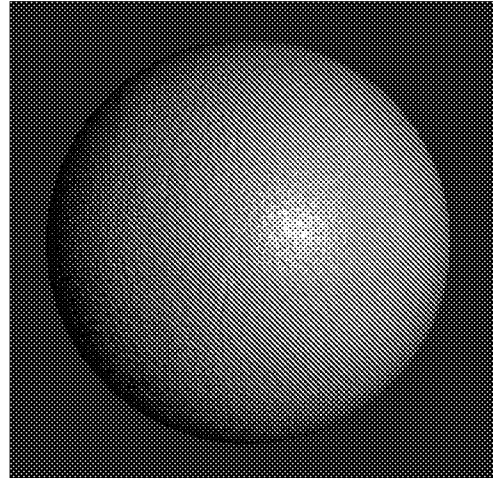

FIG. 26B

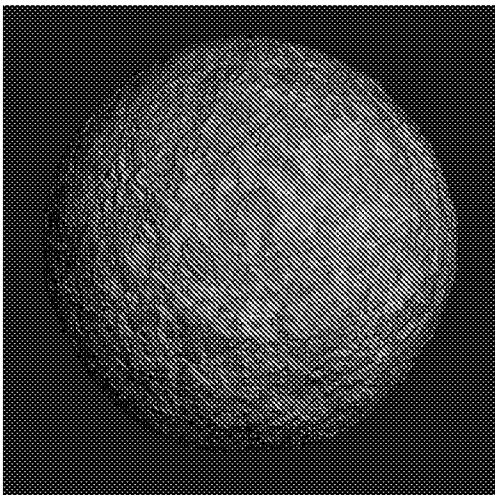

FIG. 26C

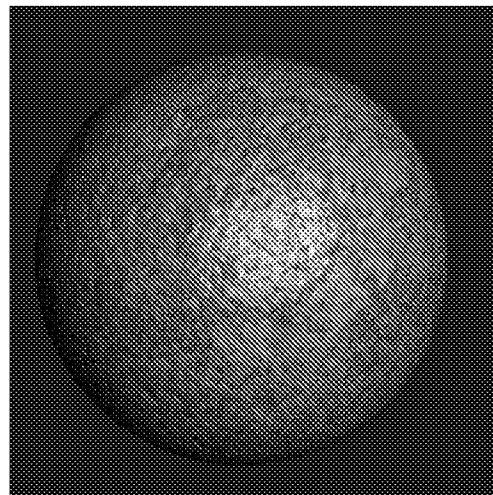

FIG. 26D

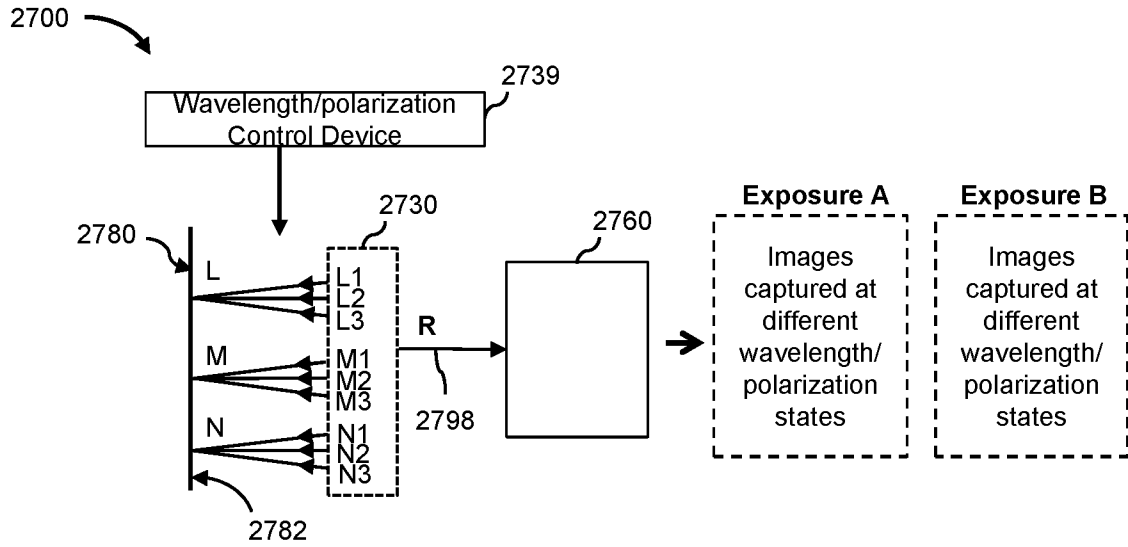

Fig. 27A

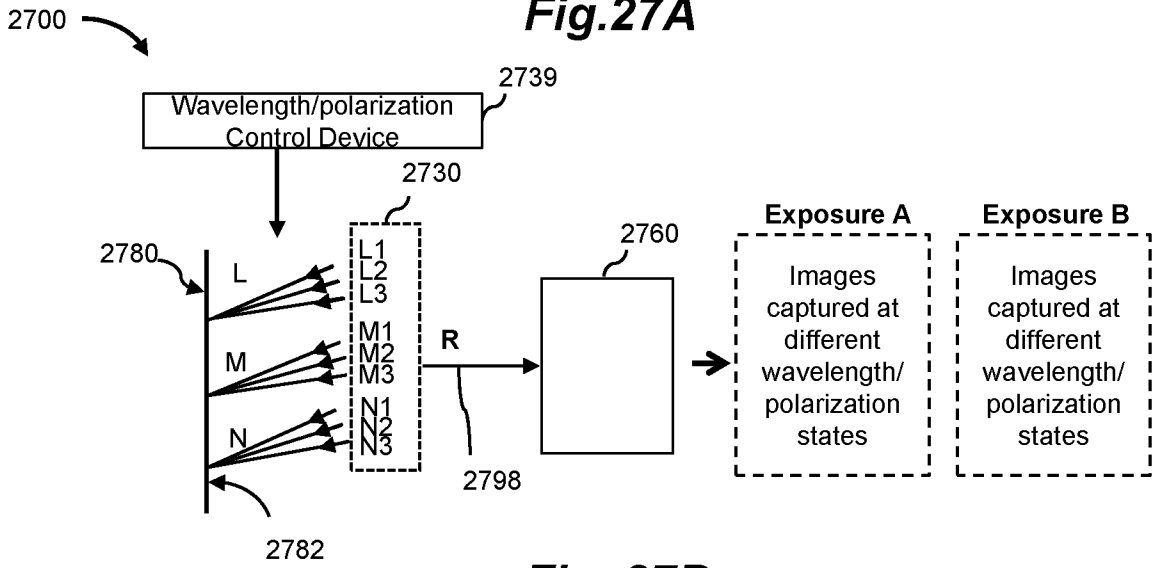

Fig. 27B

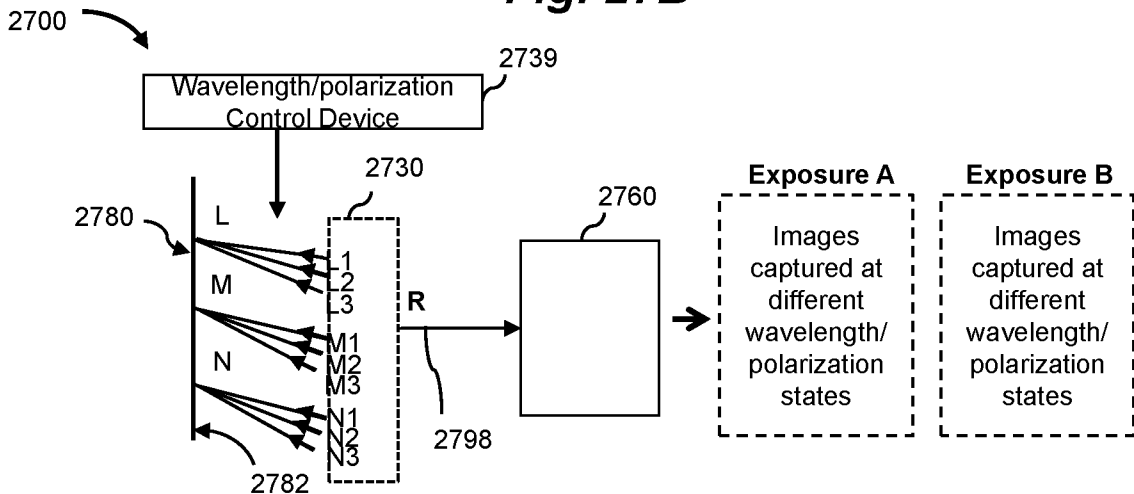

Fig. 27C

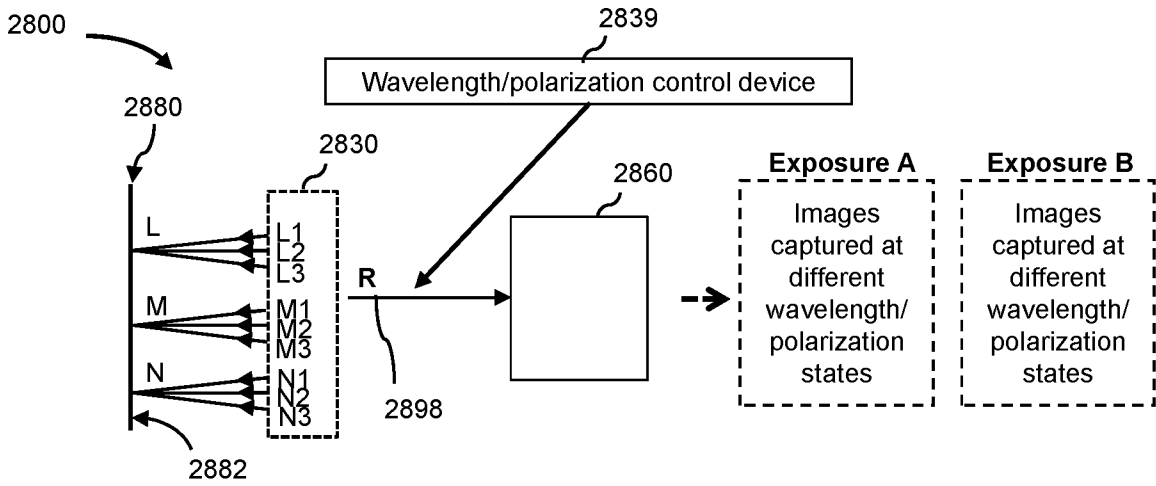

Fig. 28A

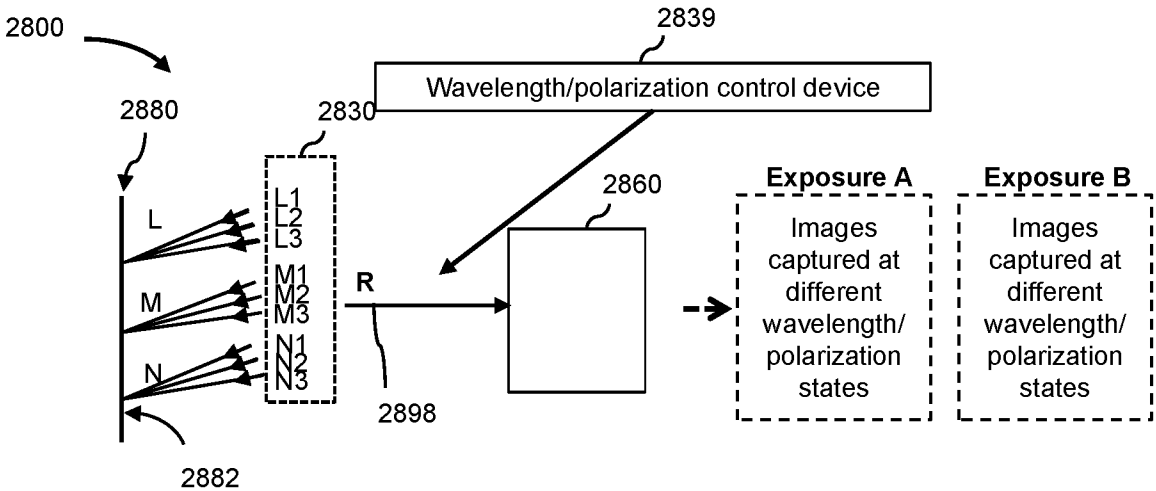

Fig. 28B

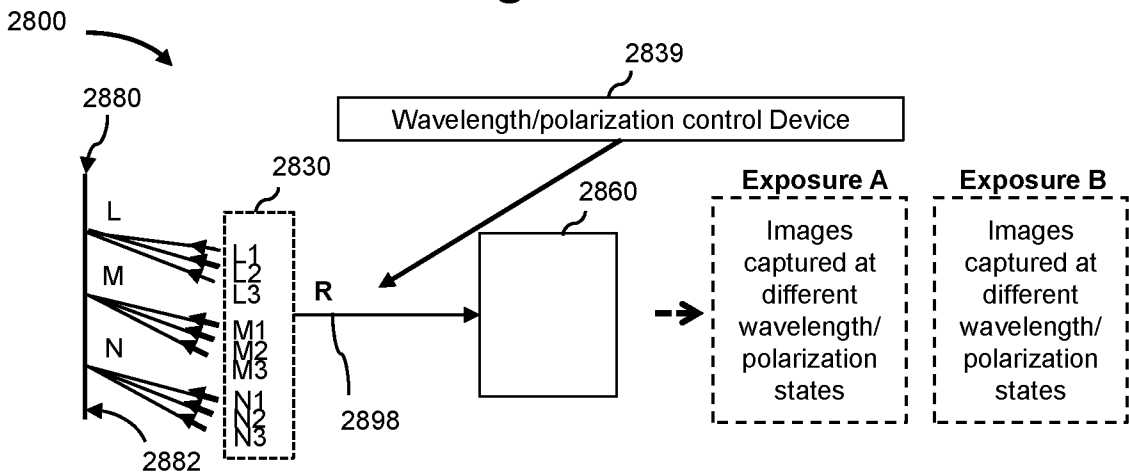

Fig. 28C

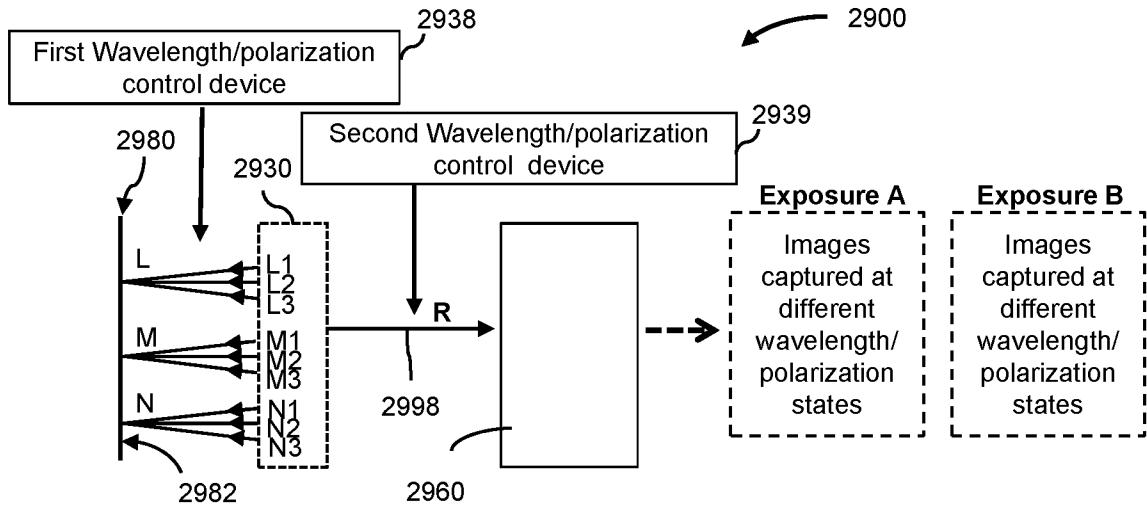

Fig. 29A

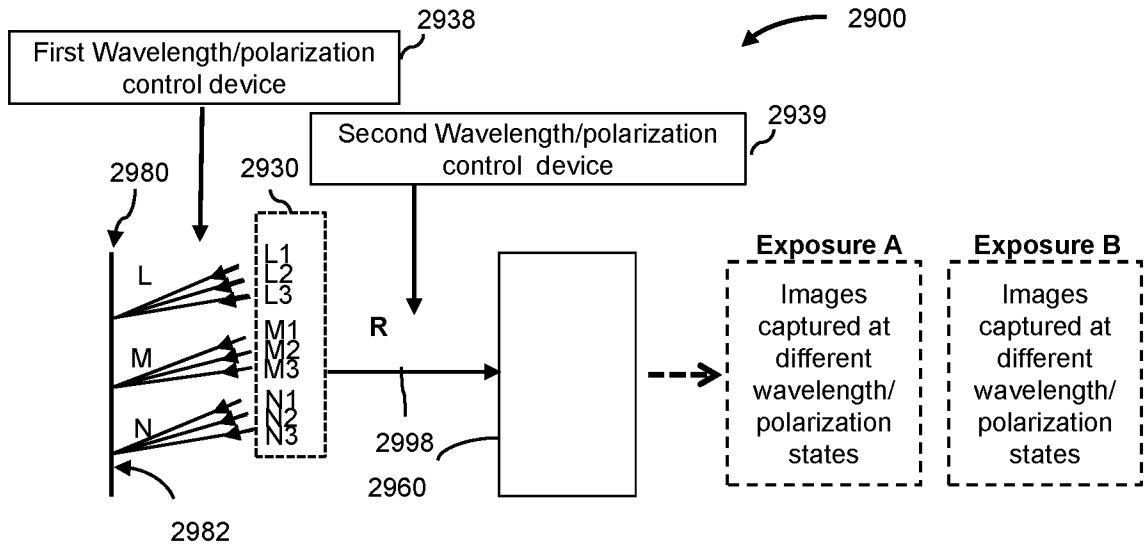

Fig. 29B

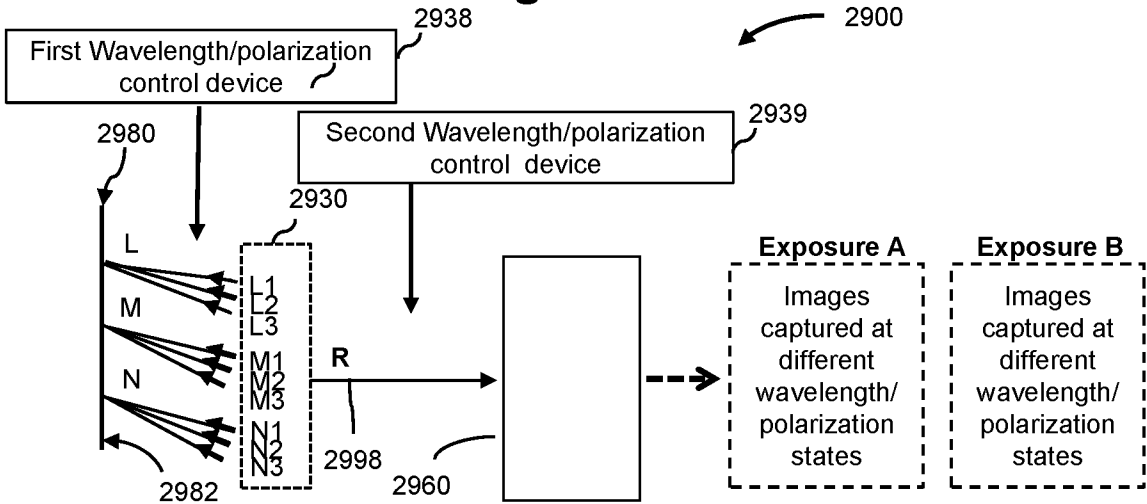

Fig. 29C

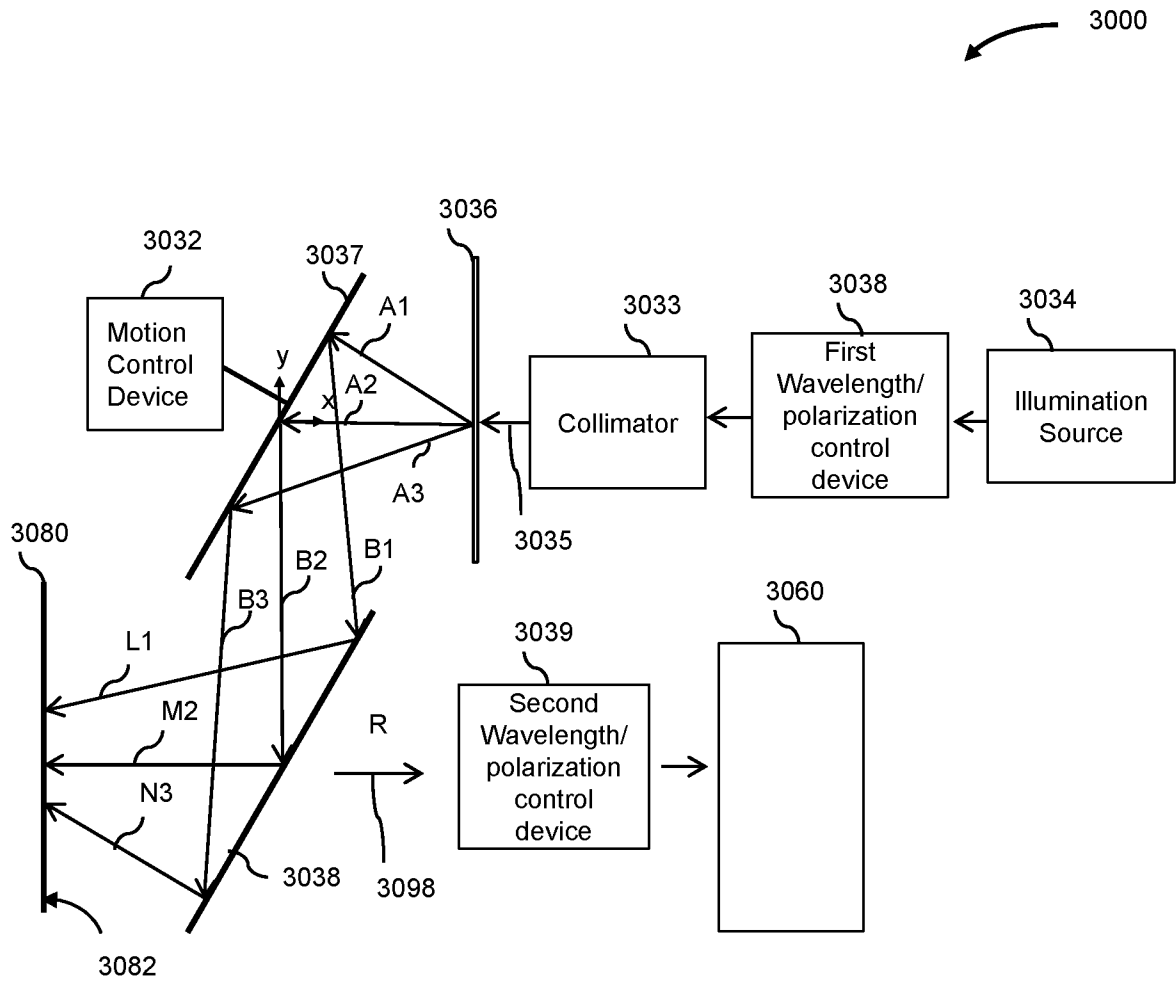

FIG. 30

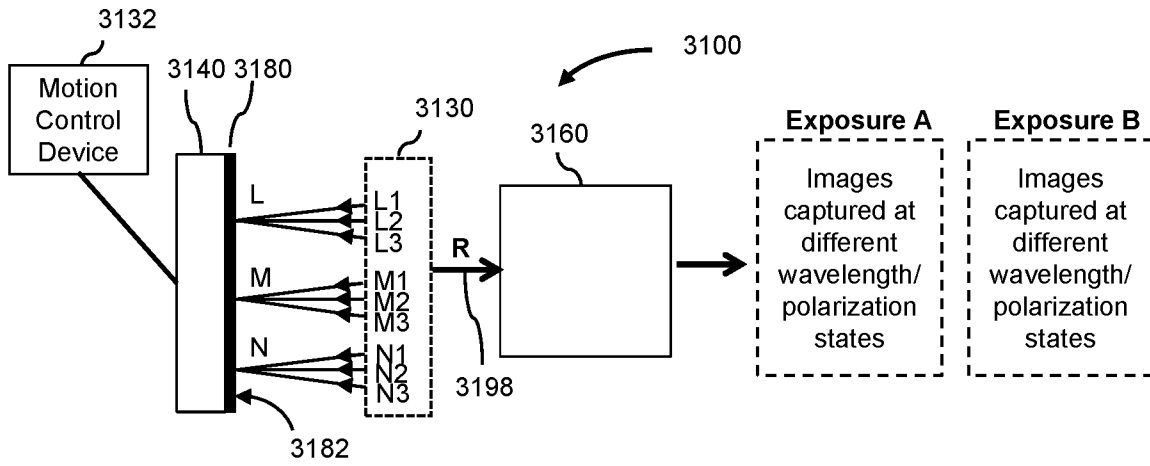

FIG. 31A

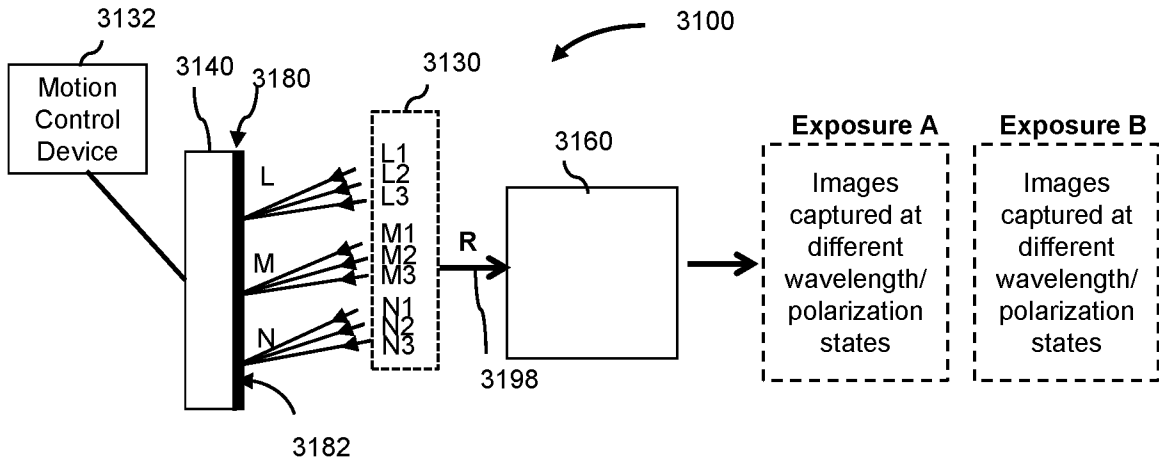

FIG. 31B

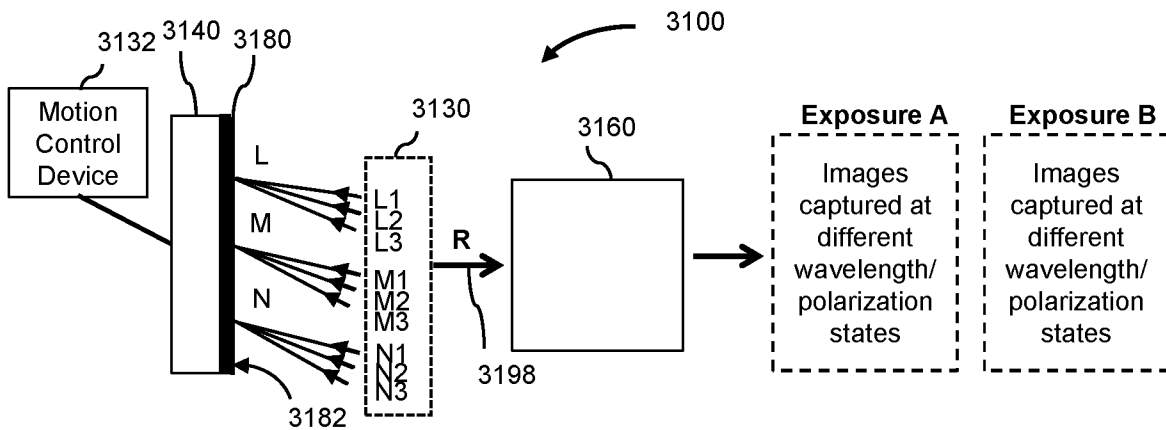

FIG. 31C

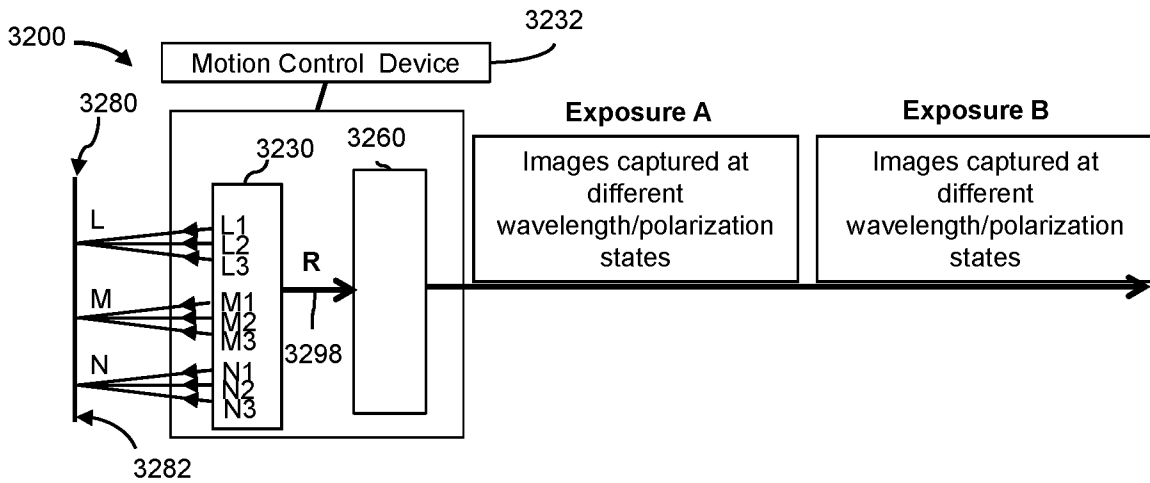

FIG. 32A

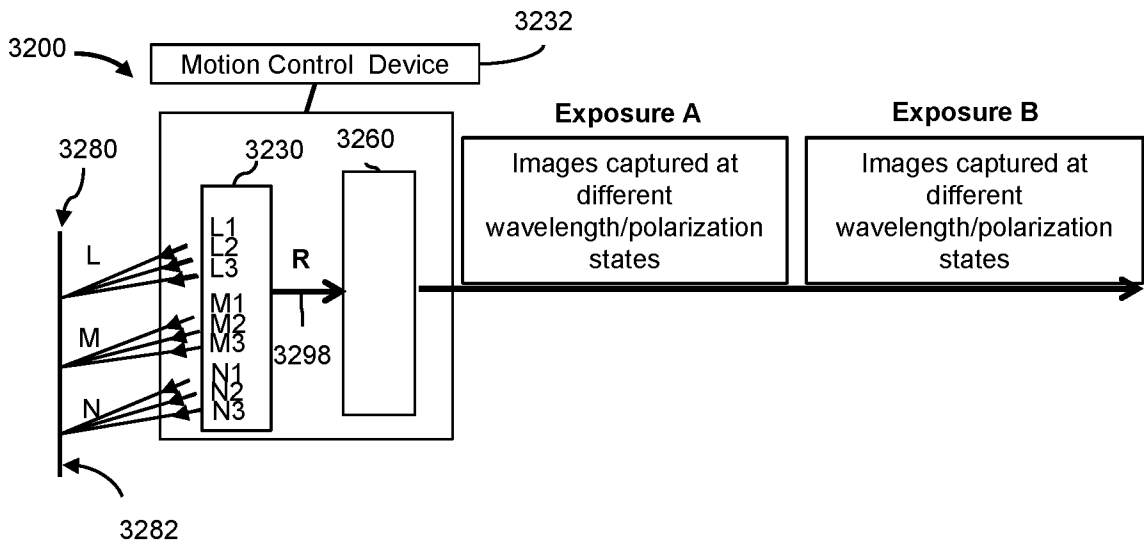

FIG. 32B

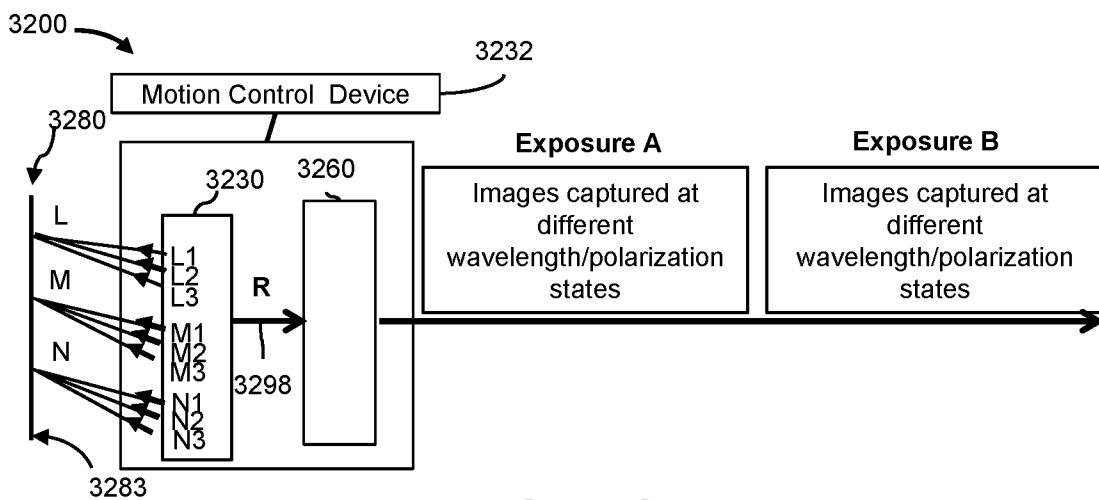

FIG. 32C

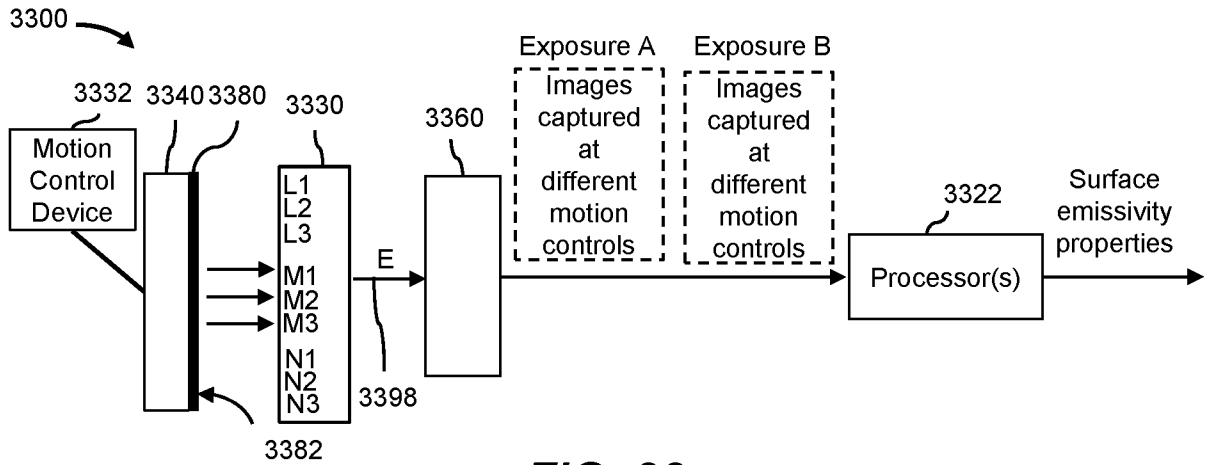

FIG. 33

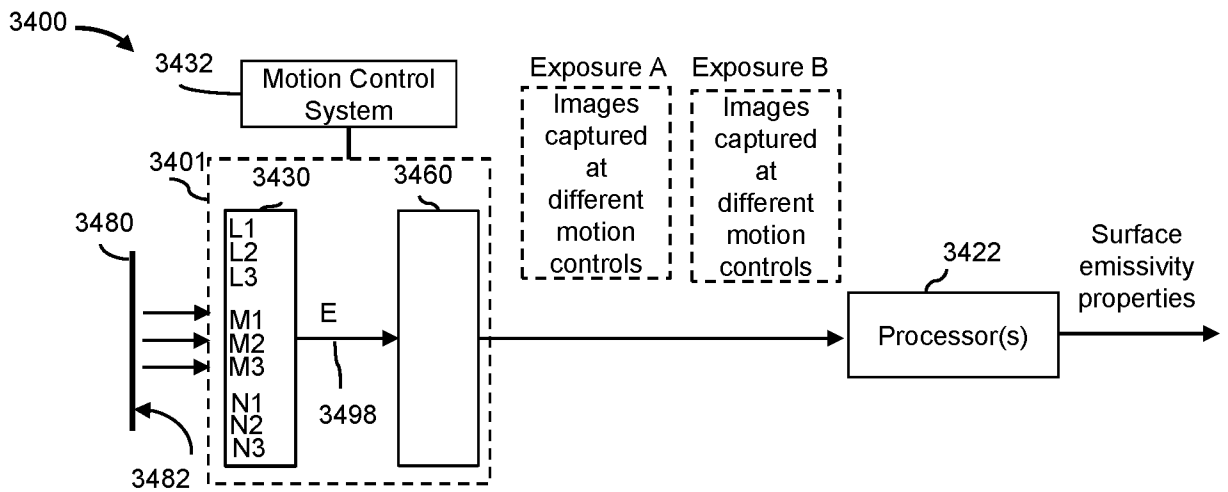

FIG. 34

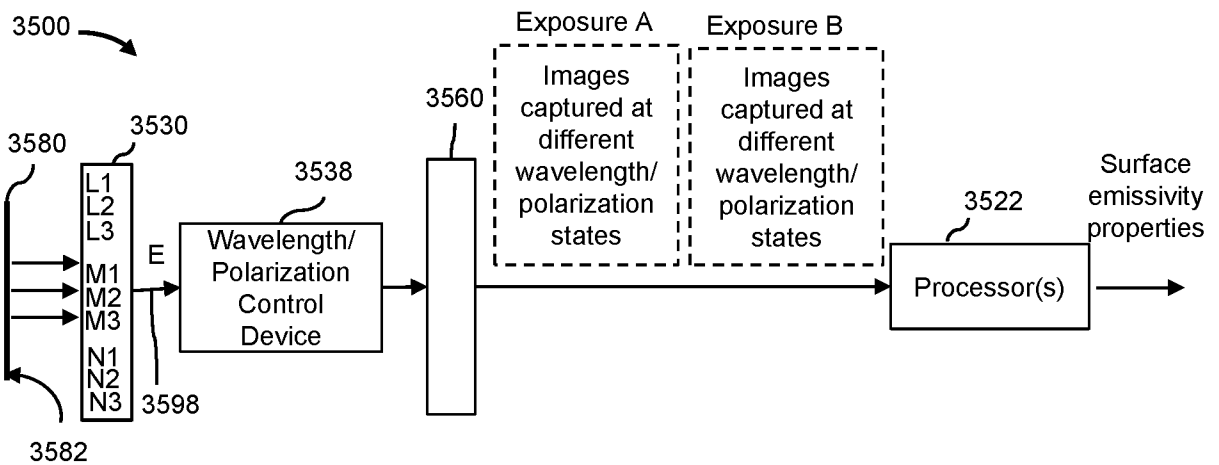

FIG. 35

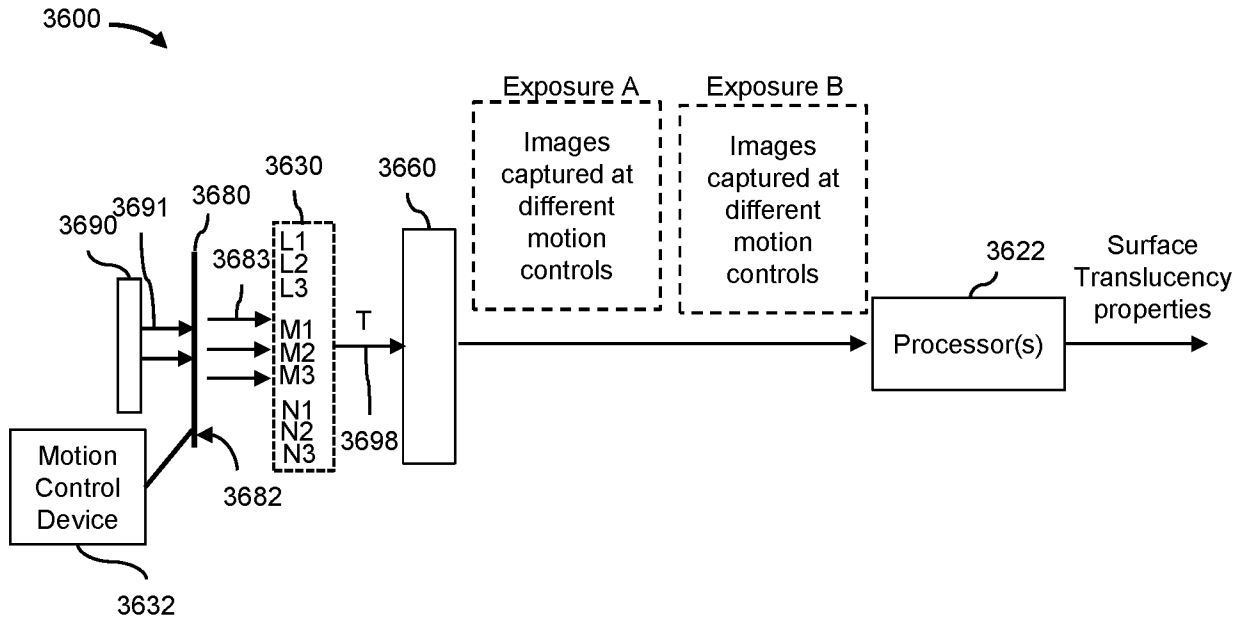

FIG. 36

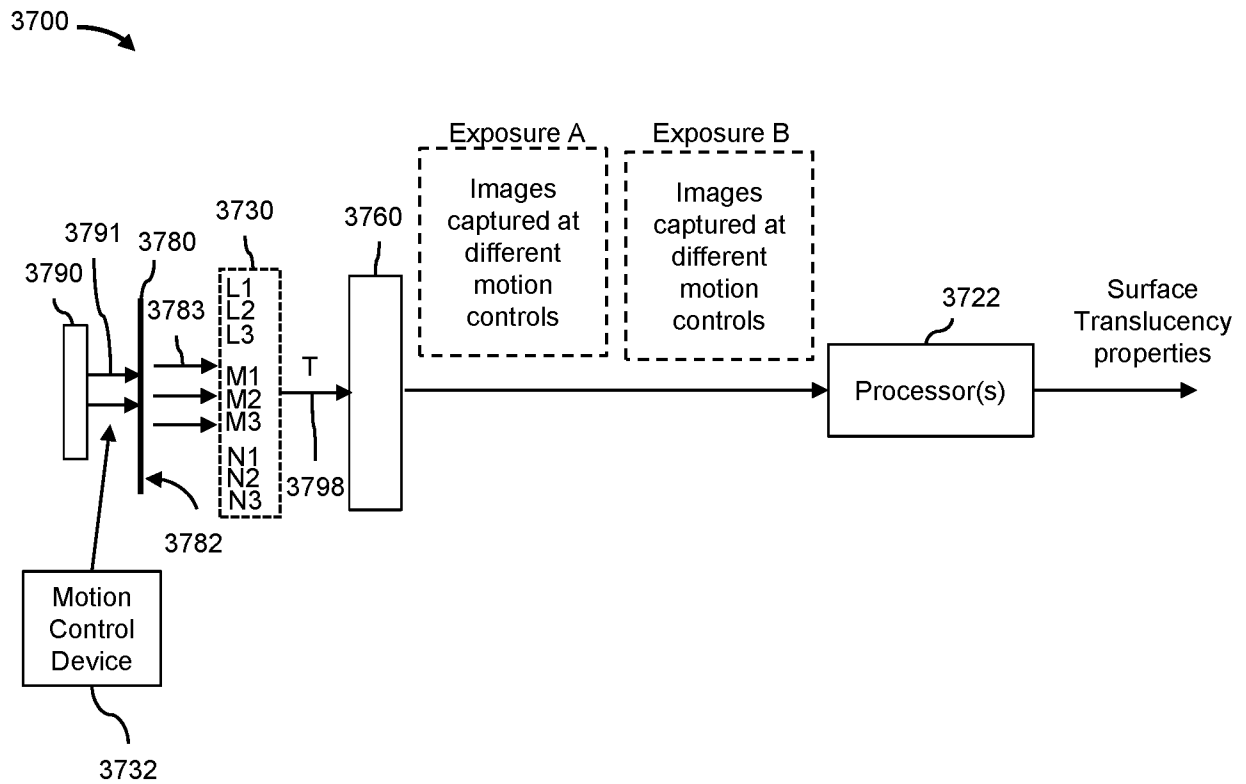

FIG. 37

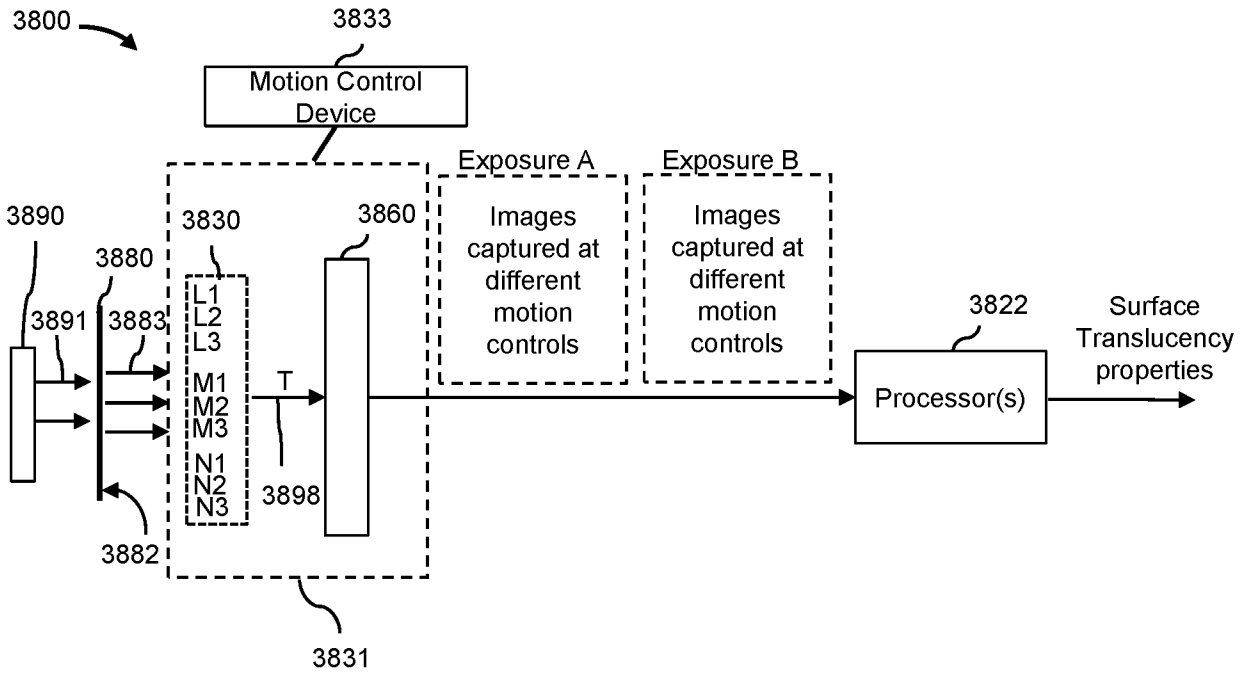

FIG. 38

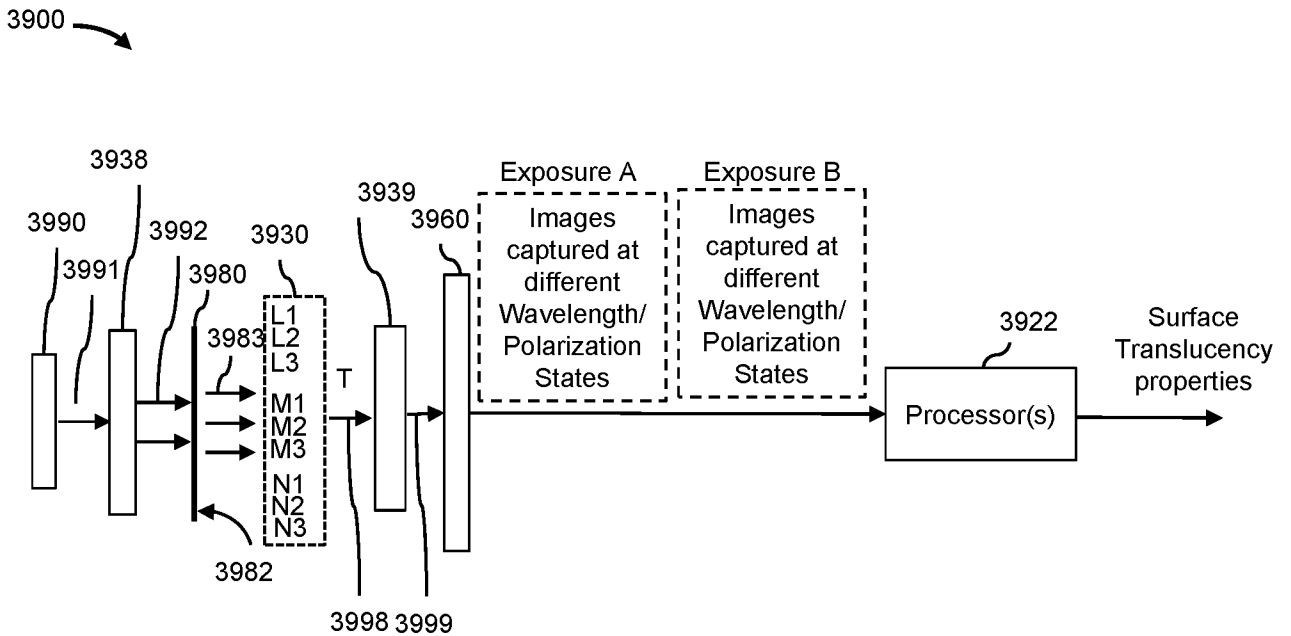

FIG. 39

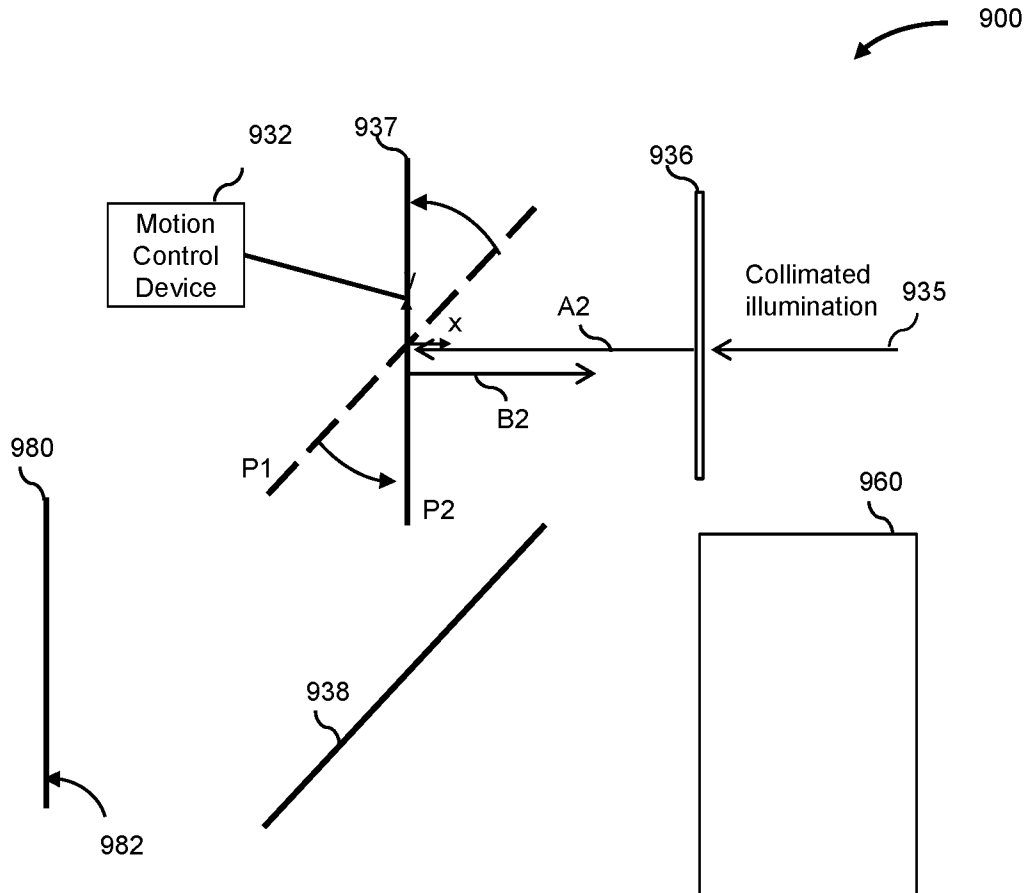

FIG. 40

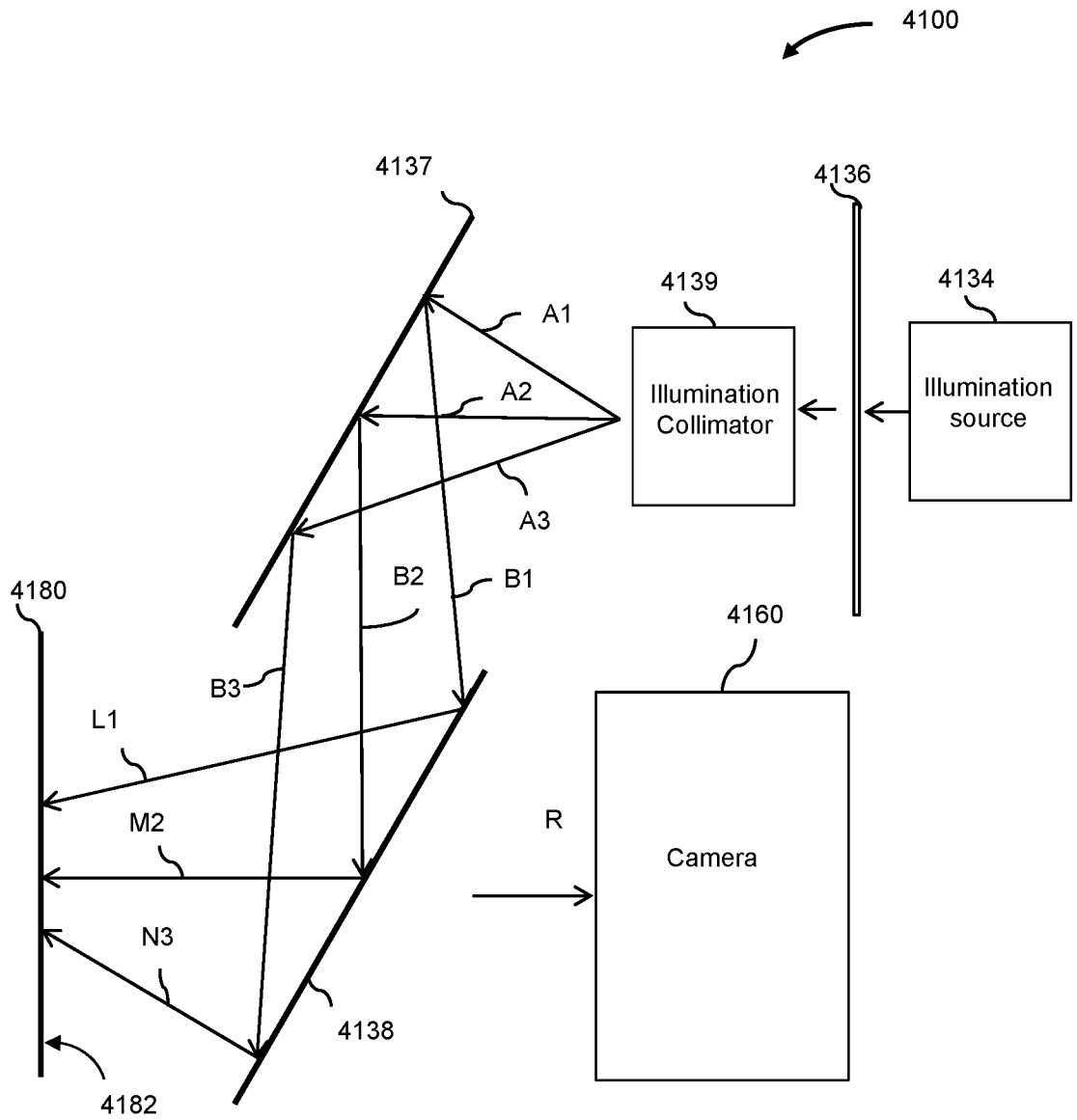

FIG. 41

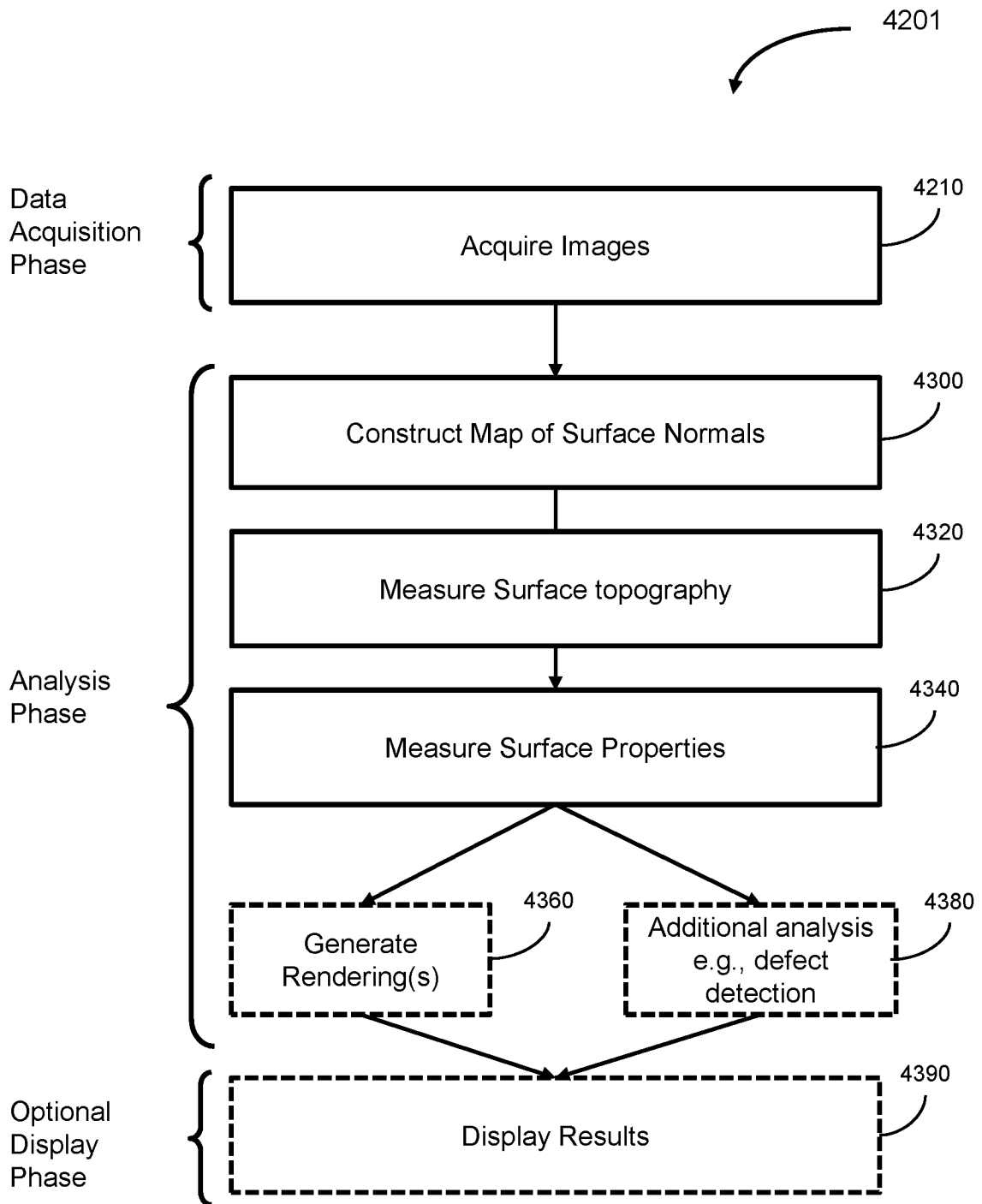

FIG. 42

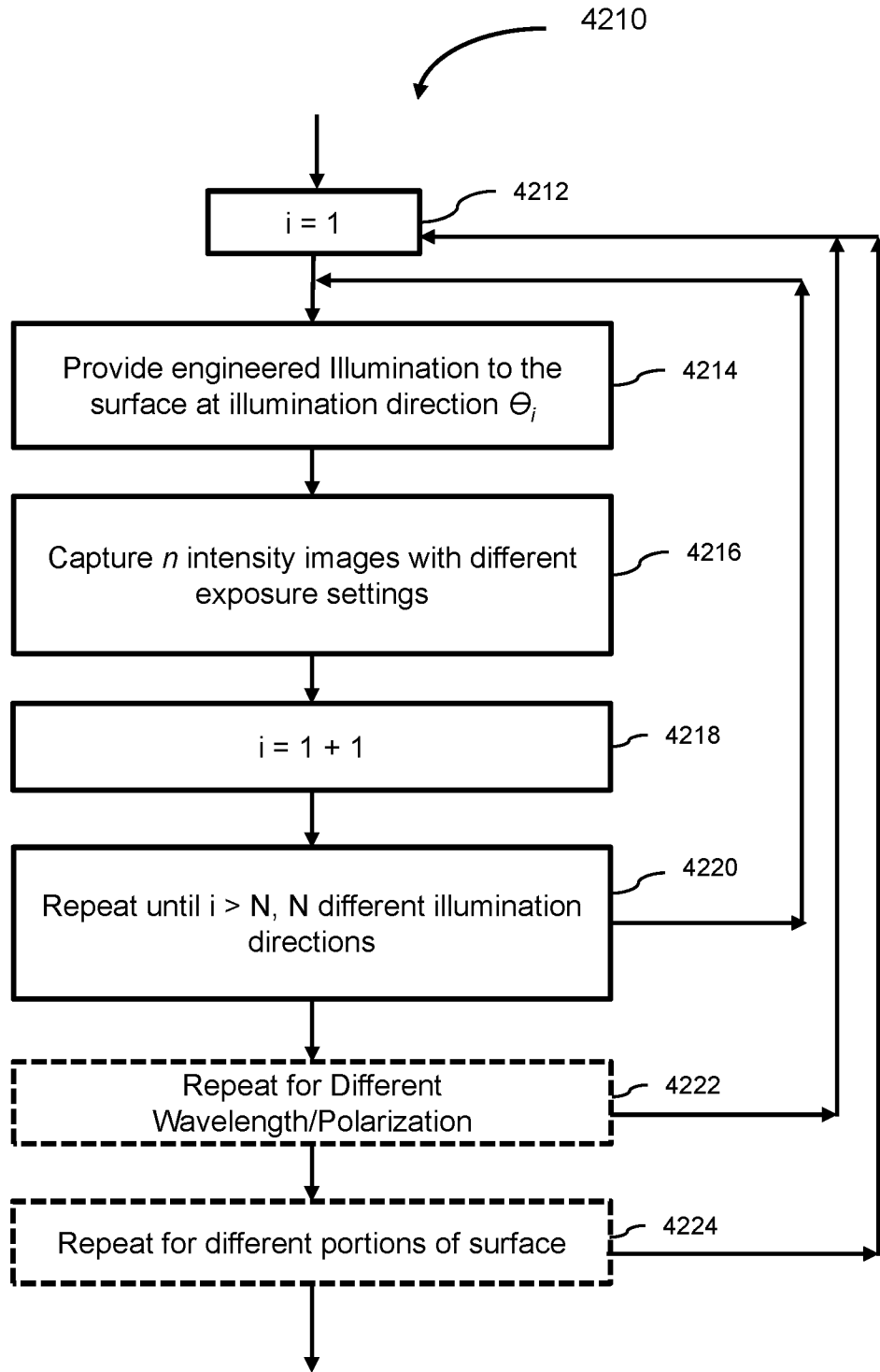

FIG. 43

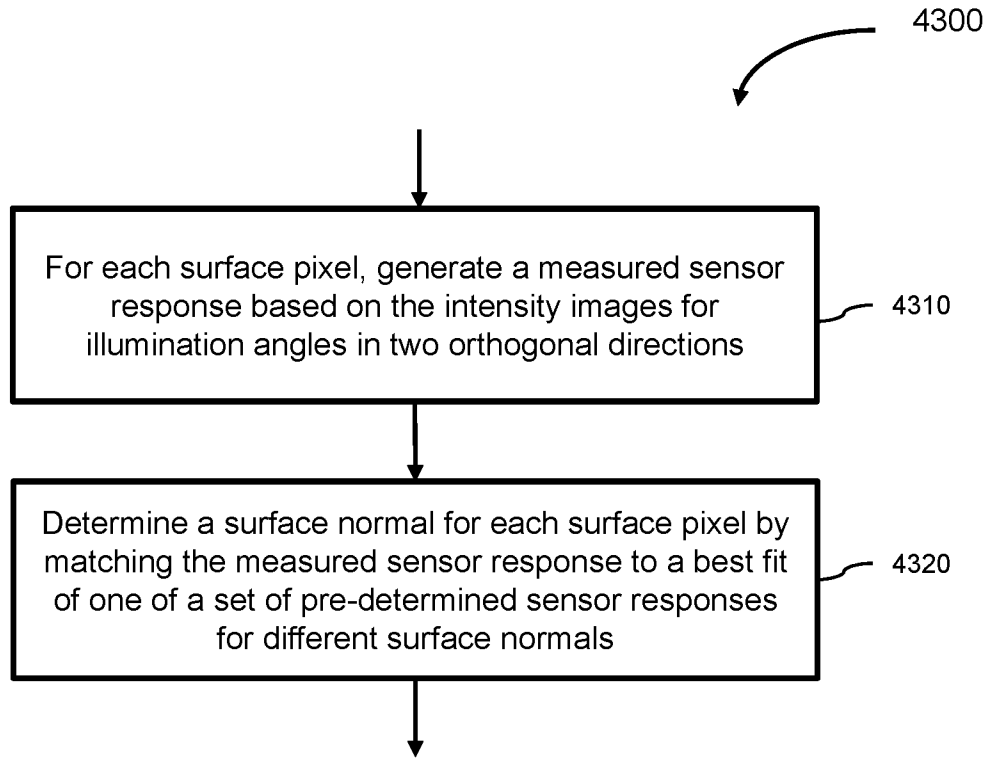

FIG. 44

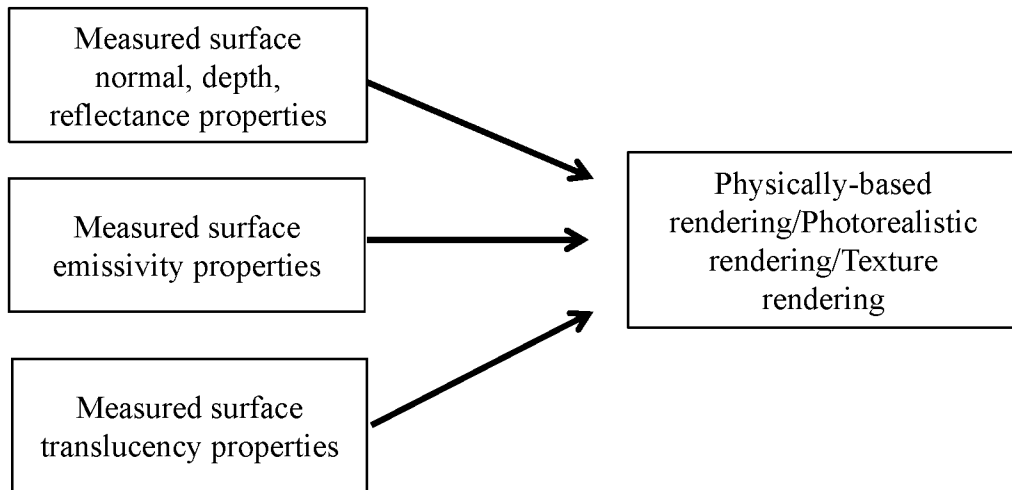

FIG. 45

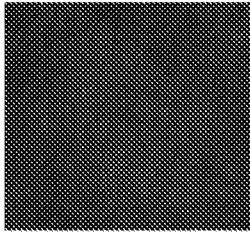

FIG. 46A

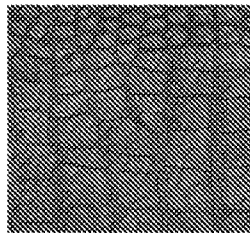

FIG. 46B

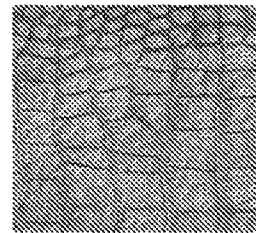

FIG. 46C

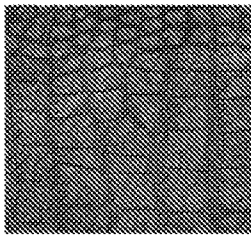

FIG. 46D

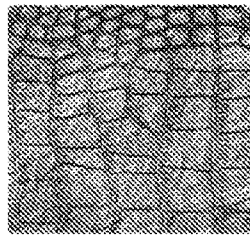

FIG. 46E

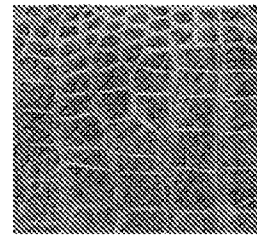

FIG. 46F

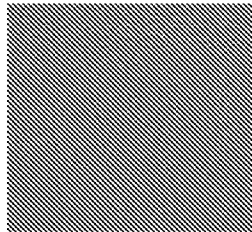

FIG. 46G

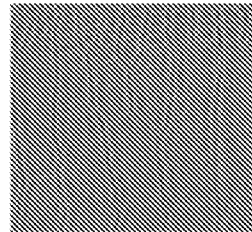

FIG. 46H

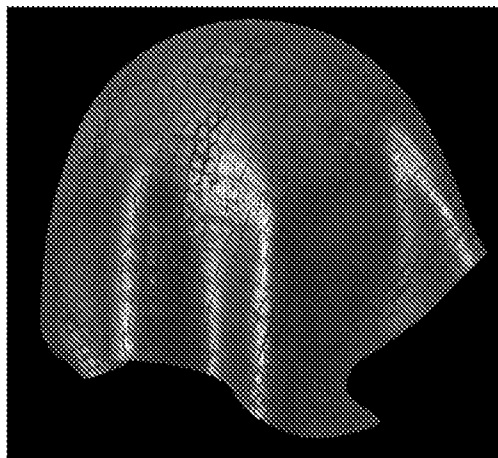

FIG. 46I

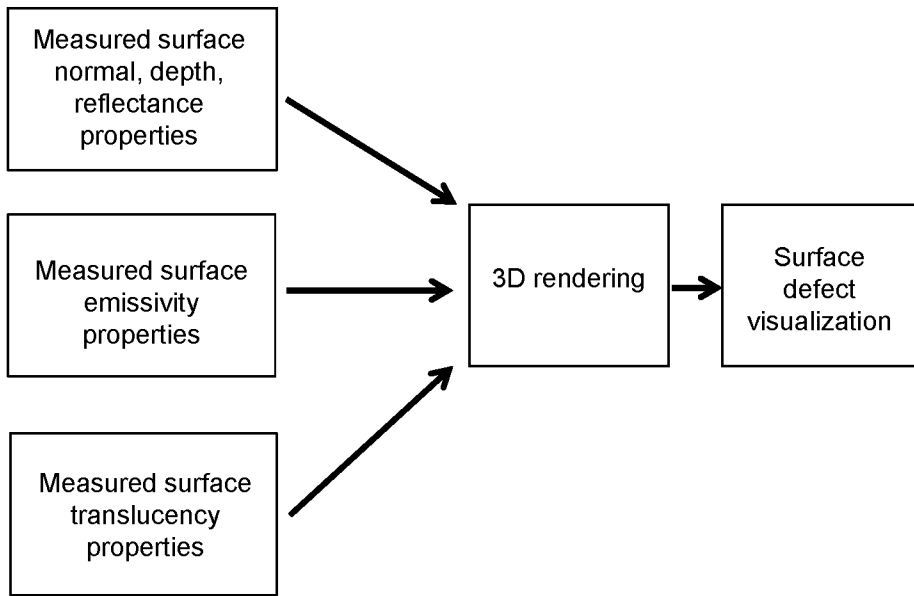

FIG. 47

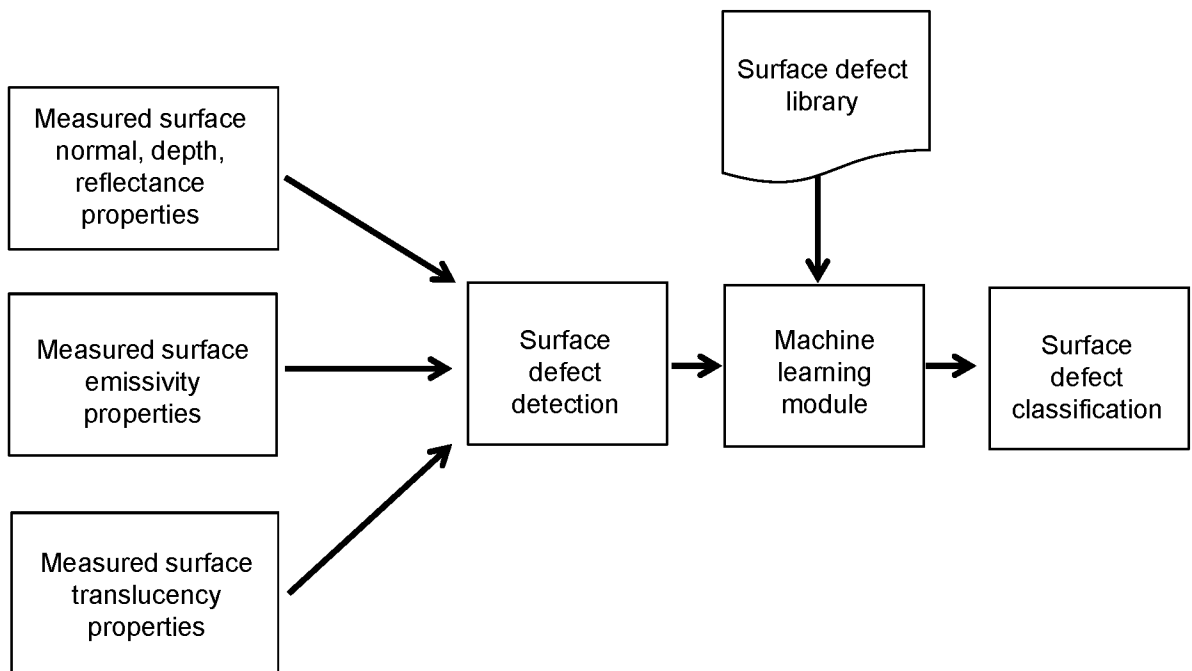

FIG. 48

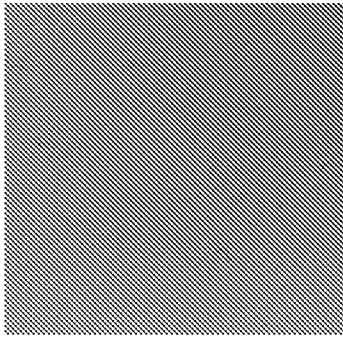

FIG. 49A



FIG. 49B



FIG. 49C

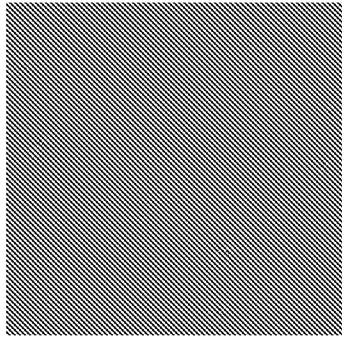

FIG. 49D

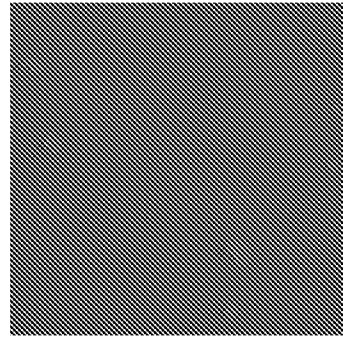

FIG. 49E

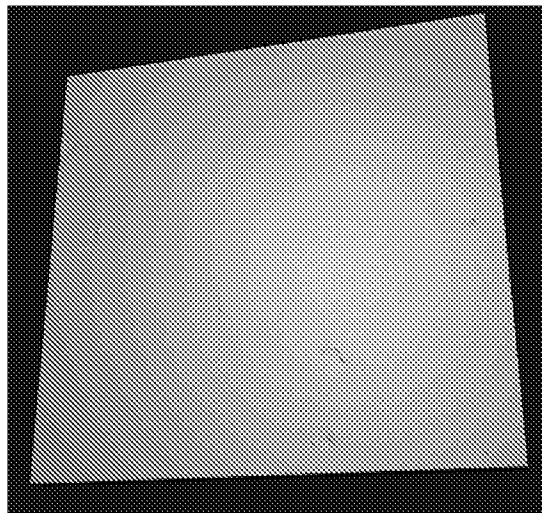

FIG. 49F

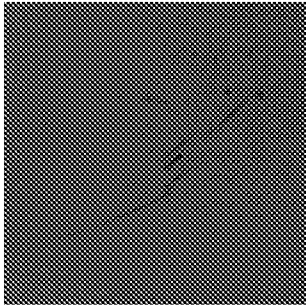

FIG. 50A



FIG. 50B

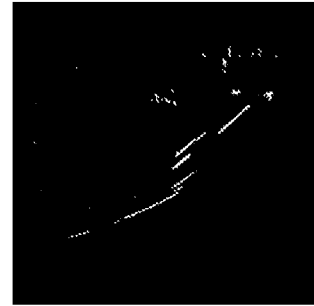

FIG. 50C

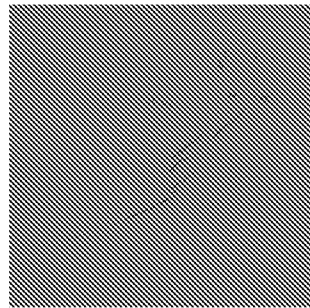

FIG. 50D

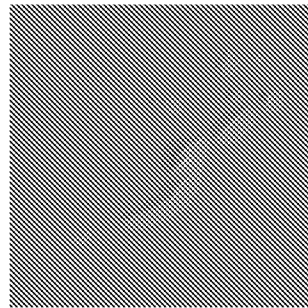

FIG. 50E

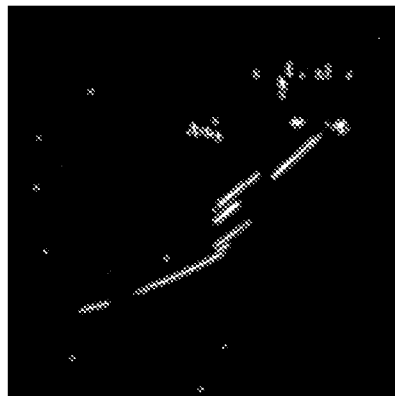

FIG. 50F

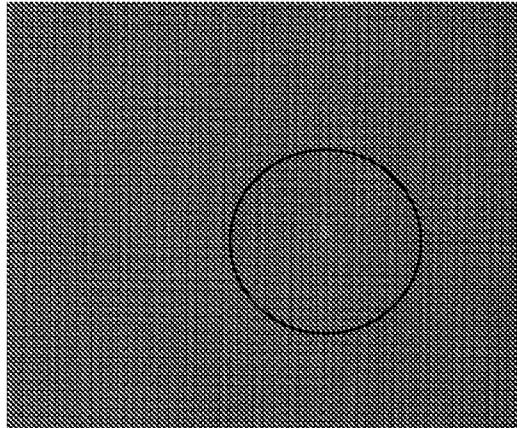

FIG. 51

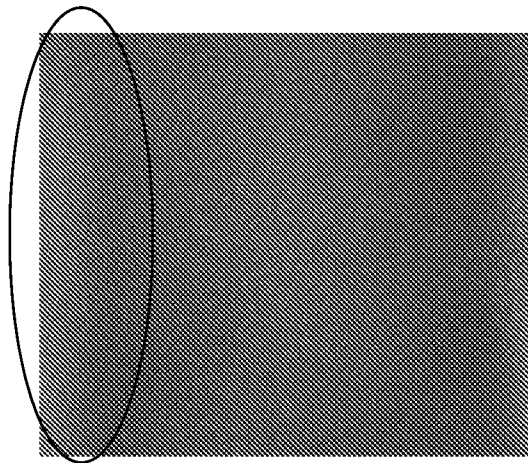

FIG. 52

INTERNATIONAL SEARCH REPORT

International application No.
PCT/US2017/043174**A. CLASSIFICATION OF SUBJECT MATTER****G01B 11/25(2006.01)i, G06T 1/00(2006.01)i, G06T 7/60(2006.01)i, H04N 5/225(2006.01)i**

According to International Patent Classification (IPC) or to both national classification and IPC

B. FIELDS SEARCHED

Minimum documentation searched (classification system followed by classification symbols)

G01B 11/25; G06F 15/00; G01N 21/64; G06T 15/80; G01B 21/20; G01N 21/88; G06T 17/20; G06T 15/50; G06T 1/00; G06T 7/60; H04N 5/225

Documentation searched other than minimum documentation to the extent that such documents are included in the fields searched

Korean utility models and applications for utility models
Japanese utility models and applications for utility models

Electronic data base consulted during the international search (name of data base and, where practicable, search terms used)

eKOMPASS(KIPO internal) & Keywords: beam, illumination direction, 3D, surface, ray bundle, sample, camera, lens, sensor, intensity image, surface normal, sensor pixel

C. DOCUMENTS CONSIDERED TO BE RELEVANT

Category*	Citation of document, with indication, where appropriate, of the relevant passages	Relevant to claim No.
X	WO 2015-080827 A1 (NANOMETRICS INCORPORATED) 04 June 2015 See paragraphs [0022]-[0032], [0040], claims 1, 2, 21, 26, and figures 1, 3A, 3B.	26
A		1-25
A	US 2012-0019533 A1 (TABELLION, ERIC) 26 January 2012 See paragraphs [0038]-[0051], claims 1, 2, and figures 1-4.	1-26
A	US 2015-0356769 A1 (IMAGINATION TECHNOLOGIES LIMITED) 10 December 2015 See paragraphs [0030], [0032], claims 1-5, and figures 1, 2.	1-26
A	US 2012-0265487 A1 (YANINE et al.) 18 October 2012 See paragraphs [0041]-[0047] and figure 1.	1-26
A	WO 2010-107434 A1 (GENERAL ELECTRIC COMPANY) 23 September 2010 See paragraphs [0012]-[0017] and figures 1, 2.	1-26

 Further documents are listed in the continuation of Box C. See patent family annex.

* Special categories of cited documents:

"A" document defining the general state of the art which is not considered to be of particular relevance

"E" earlier application or patent but published on or after the international filing date

"L" document which may throw doubts on priority claim(s) or which is cited to establish the publication date of another citation or other special reason (as specified)

"O" document referring to an oral disclosure, use, exhibition or other means

"P" document published prior to the international filing date but later than the priority date claimed

"T" later document published after the international filing date or priority date and not in conflict with the application but cited to understand the principle or theory underlying the invention

"X" document of particular relevance; the claimed invention cannot be considered novel or cannot be considered to involve an inventive step when the document is taken alone

"Y" document of particular relevance; the claimed invention cannot be considered to involve an inventive step when the document is combined with one or more other such documents, such combination being obvious to a person skilled in the art

"&" document member of the same patent family

Date of the actual completion of the international search

30 November 2017 (30.11.2017)

Date of mailing of the international search report

30 November 2017 (30.11.2017)

Name and mailing address of the ISA/KR

International Application Division
Korean Intellectual Property Office
189 Cheongsa-ro, Seo-gu, Daejeon, 35208, Republic of Korea

Facsimile No. +82-42-481-8578

Authorized officer

LEE, Chang Ho

Telephone No. +82-42-481-8288

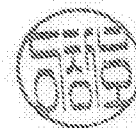

INTERNATIONAL SEARCH REPORT

Information on patent family members

International application No.

PCT/US2017/043174

Patent document cited in search report	Publication date	Patent family member(s)	Publication date
WO 2015-080827 A1	04/06/2015	EP 3074755 A1 EP 3165903 A1 TW 201527740 A TW 201627652 A US 2015-0146193 A1 US 2016-0116411 A1 US 2016-0290927 A1 US 9182351 B2	05/10/2016 10/05/2017 16/07/2015 01/08/2016 28/05/2015 28/04/2016 06/10/2016 10/11/2015
US 2012-0019533 A1	26/01/2012	CA 2744504 A1 EP 2410492 A2 US 9508191 B2	23/01/2012 25/01/2012 29/11/2016
US 2015-0356769 A1	10/12/2015	CN 105303599 A DE 102015107872 A1 GB 2526838 A GB 2526838 B US 2017-0161938 A1 US 9607429 B2	03/02/2016 10/12/2015 09/12/2015 01/06/2016 08/06/2017 28/03/2017
US 2012-0265487 A1	18/10/2012	None	
WO 2010-107434 A1	23/09/2010	CA 2754812 A1 DE 112009004742 T5 GB 2480578 A GB 2480578 B JP 2012-521005 A US 2013-0057650 A1	23/09/2010 10/01/2013 23/11/2011 14/08/2013 10/09/2012 07/03/2013