



(51) International Patent Classification:

G02B 27/01 (2006.01) G02B 6/00 (2006.01)
G02B 27/42 (2006.01) G02B 1/11 (2015.01)
G02B 5/18 (2006.01)

(21) International Application Number:

PCT/FI2018/050878

(22) International Filing Date:

04 December 2018 (04.12.2018)

(25) Filing Language:

English

(26) Publication Language:

English

(30) Priority Data:

20176158 22 December 2017 (22.12.2017) FI

(71) Applicant: **DISPELIX OY** [FI/FI]; Metsänneidonkuja 6, 02130 Espoo (FI).

(72) Inventors: **OLKKONEN, Juuso**; c/o Dispelix Oy, Metsänneidonkuja 6, 02130 Espoo (FI). **BLOMSTEDT,**

Kasimir; c/o Dispelix Oy, Metsänneidonkuja 6, 02130 Espoo (FI).

(74) Agent: **SEPPO LAINE OY**; Itämerenkatu 3 A, 00180 Helsinki (FI).

(81) Designated States (unless otherwise indicated, for every kind of national protection available): AE, AG, AL, AM, AO, AT, AU, AZ, BA, BB, BG, BH, BN, BR, BW, BY, BZ, CA, CH, CL, CN, CO, CR, CU, CZ, DE, DJ, DK, DM, DO, DZ, EC, EE, EG, ES, FI, GB, GD, GE, GH, GM, GT, HN, HR, HU, ID, IL, IN, IR, IS, JO, JP, KE, KG, KH, KN, KP, KR, KW, KZ, LA, LC, LK, LR, LS, LU, LY, MA, MD, ME, MG, MK, MN, MW, MX, MY, MZ, NA, NG, NI, NO, NZ, OM, PA, PE, PG, PH, PL, PT, QA, RO, RS, RU, RW, SA, SC, SD, SE, SG, SK, SL, SM, ST, SV, SY, TH, TJ, TM, TN, TR, TT, TZ, UA, UG, US, UZ, VC, VN, ZA, ZM, ZW.

(84) Designated States (unless otherwise indicated, for every kind of regional protection available): ARIPO (BW, GH, GM, KE, LR, LS, MW, MZ, NA, RW, SD, SL, ST, SZ, TZ, UG, ZM, ZW), Eurasian (AM, AZ, BY, KG, KZ, RU, TJ,

(54) Title: INTERFERENCE-FREE WAVEGUIDE DISPLAY

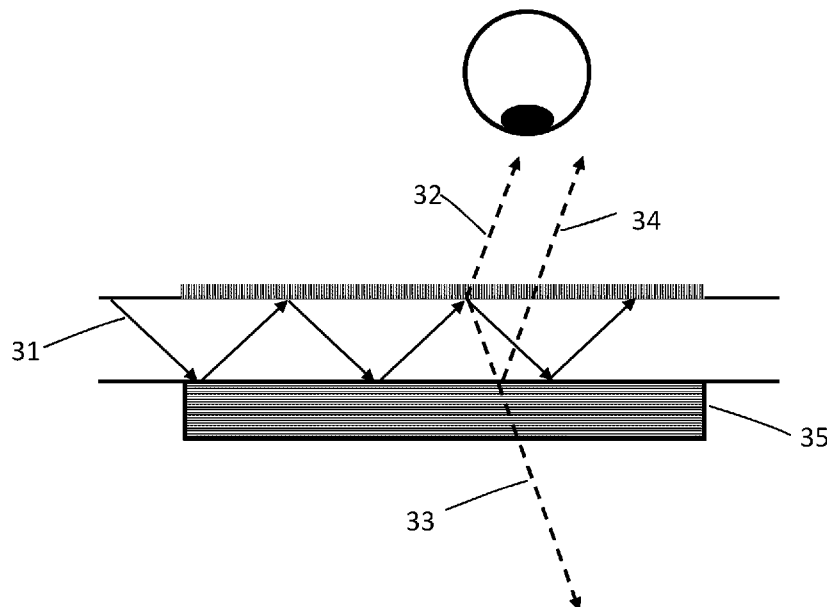

Fig. 3

(57) Abstract: The invention relates to a diffractive waveguide display device comprising an image projector capable of emitting laser rays at one or more wavelengths, a waveguide body having a first surface and an opposite second surface and adapted to guide said laser rays from the image projector between the first surface and the second surface, an out-coupling diffractive optical element on said first surface for coupling said laser rays out of the waveguide body, and an anti-interference coating (35) arranged on the second surface of the waveguide body aligned with the out-coupling diffractive optical element.



TM), European (AL, AT, BE, BG, CH, CY, CZ, DE, DK, EE, ES, FI, FR, GB, GR, HR, HU, IE, IS, IT, LT, LU, LV, MC, MK, MT, NL, NO, PL, PT, RO, RS, SE, SI, SK, SM, TR), OAPI (BF, BJ, CF, CG, CI, CM, GA, GN, GQ, GW, KM, ML, MR, NE, SN, TD, TG).

Published:

— *with international search report (Art. 21(3))*

Interference-free waveguide display

Field of the Invention

The invention relates to diffractive waveguide displays. In particular, the invention relates to an improved out-coupling arrangement in such displays.

5 Background of the Invention

Head-mounted displays (HMDs) and head-up displays (HUDs) can be implemented using waveguide technology. Light can be coupled to a waveguide, redirected therein or coupled out of the waveguide using diffraction gratings. In one conventional display design, light is directed from a projector to an in-coupling grating, which diffracts the
10 wavelengths of the incoming light into the waveguide, where they propagate via total internal reflections towards an out-coupling grating. The out-coupling grating diffracts light out of the waveguide, reproducing the image originally displayed to the in-coupling grating.

Diffractive waveguides when used with light sources having narrow spectral bandwidth
15 (such as lasers and optically filtered LEDs) suffer typically from interference patterns visible in the virtual image. These interference patterns are often cylindrically symmetric and referred to as Newton rings. This is an undesired effect since it weakens the quality of the image produced by the display.

Summary of the Invention

20 It is an aim of the invention to overcome the interference problem and to provide an interference-free out-coupling arrangement for diffractive displays and a diffractive display utilizing such arrangement.

The invention is based on preventing the formation of interference patterns using an anti-interference coating on a surface of the waveguide body opposite to the surface where the
25 out-coupling grating is located. The anti-interference coating reduces the intensity of stray rays that interfere with the out-coupled rays.

In particular, the invention is characterized by what is stated in the independent claims.

Thus, according to one aspect, the invention provides a diffractive waveguide display device comprising

- an image projector capable of emitting laser rays at one or more wavelengths,
- a waveguide body having a first surface and an opposite second surface and
5 adapted to guide said laser rays from the image projector between the first surface and the second surface,
- an out-coupling diffractive optical element on said first surface for coupling said laser rays out of the waveguide body,
- an anti-interference coating arranged on the second surface of the waveguide
10 body aligned with the out-coupling diffractive optical element.

The invention offers significant benefits. The invention prevents or at least decreases the generation of visually observable Newton rings due to internal stray reflections and interference of reflected light with the out-coupled light. This is of particular relevance if the coherence length of the laser rays of the image projector is at the same order or
15 higher than the optical path difference of the interfering rays.

The invention also suits for see-through displays, in which passing of ambient light to the user's eye is desired.

The dependent claims are directed to selected embodiments of the invention.

In some embodiments, the anti-interference coating is laterally uniform. Thus, it may have
20 spatially constant optical properties.

In some embodiments, the anti-interference coating is laterally non-uniform. It may have have a plurality of regions, either distinct or continuous, of different optical properties, such as angular reflectivity characteristics. In more detail, the coating may have a first zone corresponding to a first field-of-view angle and having first optical properties, and a
25 second zone corresponding to a second field-of-view angle and having second optical properties different from the first optical properties.

Spatially varying optical properties may be achieved using a coating having laterally non-uniform thickness and/or laterally non-uniform multilayer structure and/or providing a plurality of distinct coating regions adjacent to each other, the regions having different
30 optical properties.

The properties of the coating may be made to vary over the region of the out-coupling grating so that the thickness in each location thereof is optimized for angles emanating from that area to the location of the eye of the user of the device.

In some embodiments, the anti-interference coating comprises a multilayer coating with alternating layers of different materials having different refractive indices, for example a stack of alternating layers of Al_2O_3 or TiO_2 and MgF_2 or SiO_2 .

In some embodiments, the coating comprises a single layer structure, such as a single layer of MgF_2 .

In some embodiments, the display comprises a plurality of waveguide bodies stacked on top of each other. In particular, each body may comprise an anti-interference coating with different optical properties, such as wavelength or angle specificity.

In some embodiments, the anti-interference coating has an incident angle -dependent reflectance, the reflectance being at lowest for zero incident angle.

Next, embodiments of the invention and advantages thereof are discussed in more detail with reference to the attached drawings.

Brief Description of the Drawings

Figs. 1 and 2 show cross-sectional side views of two possible out-coupling arrangements without an anti-interference coating.

Figs. 3 - 5 show cross-sectional side views of out-coupling arrangement according to embodiments of the invention.

Detailed Description of Embodiments

Fig. 1 shows an out-coupling arrangement, in which the out-coupling grating 14 is located on the eye side of the waveguide. When the light field 15 propagating via total-internal reflections inside the lightguide 13 interacts with the out-coupling grating 14 at the air/lightguide interface 11, two light fields 16 and 17 are produced. The light field 16 propagates towards the eye 19 and the light field 17 towards the opposite lightguide interface 12. The light field 17 reflects partially from the interface and the light field 18 is

then formed. The reflected light field 18 will interfere with the light field 16 if their coherence length is larger than their optical path length difference.

Fig. 2 shows an out-coupling arrangement, in which the out-coupling grating 24 is located on the world side (i.e. other side than the eye) of the waveguide. When the light field 25
5 interacts with the out-coupling grating 24 located on the lightguide/air interface 22, diffraction creates the out-coupled light field 26. This light field propagates on the interface 21 where it partially reflects towards the interface 22. The reflected field 27 propagates back towards the out-coupler where it gets reflected towards the eye. The light fields 26 and 28 interfere if their optical path length difference is smaller than the coherence length
10 of the light fields.

Next, several embodiments of anti-interference coatings suitable for preventing interference patterns formed by the interference of out-coupled laser rays and stray rays reflecting inside the waveguide body, are discussed.

The strength of interference patterns occurring in the configurations of Fig. 1 and Fig. 2
15 can be greatly reduced by producing an anti-interference coating on the surface that is opposite to the out-coupling grating as illustrated in Fig. 3. The anti-interference coating 35 reduces the intensity of light field 34 so that no Newton rings are formed into the virtual image received by the user.

The coating can be a single or a multilayer structure. The layer thicknesses are typically
20 smaller than the free space wavelength of incident light. For example, if the lightguide refractive index is 2.0, a single magnesium fluoride (MgF_2) layer with the thickness of 50 – 150 nm can be sufficient for visible wavelengths of the incident light. Multilayer structure can consist of a stack of multiple pairs of high and low refractive index material layers. In some configuration, the stack consists of multiple identical pairs. In some configurations,
25 all the layers can have different thicknesses and/or refractive indexes. The stack can be numerically optimized by using multilayer solvers based directly on Maxwell equations. The basic idea is to find a multilayer structure that reflects as little as possible out-coupled light towards the user's eye but still remains the total internal reflection property for light fields incident on the out-coupling region from other regions of the lightguide. The high
30 refractive index materials can be, for example, metal oxides such as Al_2O_3 and TiO_2 . The low refractive index medium can be, e.g. MgF_2 , SiO_2 , or some aerogel material. Aerogel materials are attractive as their refractive index is close to 1. Also low refractive index materials based on fluorinated monomers can be used.

Figs. 4 and 5 illustrate spatially varying anti-interference coatings. Light fields of different field of view (FOV) angles exit the out-coupling grating from well-defined regions. This can be utilized when the anti-interference coating is designed. The coating can have for example thickness that varies over the out-coupling regions so that the thickness in each location is optimized for angles emanating from that area into the user's eye. This makes it possible to design an anti-interference coating that works for augmented reality (AR) devices having large FOV.

Figure 4 illustrates a single layer coating 41 with varying thickness over the out-coupling region. Varying thickness can be realized both with single and multilayer coating structures. In the case of a multilayer coating, the number of layers and/or the thickness of individual layers can be varied.

Figure 5 shows a multilayer configuration comprising a plurality of segments 51-55 arranged laterally with respect to each other in the waveguide plane. The number of segments and their optical properties are optimized to reduce the visibility of interference patterns in the user's field of view.

The anti-interference coating may have a wide (e.g. > 300 nm) low-reflectivity wavelength band or one or more narrow low-reflectivity bands (each band being e.g. < 50 nm FWHM) corresponding to the wavelength or wavelengths of the laser projector.

In some embodiments, the waveguide body has an index of refraction of 1.5 or more, such as 1.7 or more, in particular 2.0 or more. The thickness of the waveguide body is typically 1.5 mm or less, such as 1.1 mm or less, for example 0.5 mm or less.

In some embodiments, the waveguide display device is a see-through display device and the anti-interference coating and the out-coupling grating have high transmittance, such as a transmittance of at least 75 %, for ambient white light.

Embodiments of the invention can be utilized in various personal display devices, augmented reality (AR), virtual reality (VR) and mixed reality (MR) devices, like near-to-the-eye displays (NEDs) and other head-mounted displays (HMDs), as well as head-up displays (HUDs), in their different forms.

Claims

1. A diffractive waveguide display device comprising
 - an image projector capable of emitting laser rays at one or more wavelengths,
 - a waveguide body having a first surface and an opposite second surface and
5 adapted to guide said laser rays from the image projector between the first surface and the second surface,
 - an out-coupling diffractive optical element on said first surface for coupling said laser rays out of the waveguide body,
 - an anti-interference coating arranged on the second surface of the waveguide
10 body aligned with the out-coupling diffractive optical element, wherein the anti-interference coating is laterally non-uniform.
2. The device according to claim 1, wherein the anti-interference coating has different laterally non-uniform optical properties, such as angular reflectivity characteristics.
3. The device according to claim 1 or 2, wherein the anti-interference coating comprises
 - 15 – a first zone corresponding to a first field-of-view angle and having first optical properties, and
 - a second zone corresponding to a second field-of-view angle and having second optical properties different from the first optical properties.
4. The device according to any of the preceding claims, wherein the anti-interference
20 coating has laterally non-uniform thickness.
5. The device according to any of the preceding claims, wherein the anti-interference coating has laterally non-uniform multilayer structure.
6. The device according to any of the preceding claims, wherein the anti-interference
25 coating comprises a plurality of distinct regions adjacent to each other, the regions having different optical properties.
7. The device according to any of the preceding claims, wherein the thickness or layer structure of the anti-interference coating varies over the out-coupling diffractive optical element so that the thickness or layer structure in each location is optimized for angles emanating from that area to the location of the eye of the user of the device.

8. The device according to any of the preceding claims, wherein the anti-interference coating comprises a multilayer coating with alternating layers of different materials having different refractive indices, for example a stack of alternating layers of Al_2O_3 or TiO_2 and MgF_2 or SiO_2 .
- 5 9. The device according to any of claims 1 - 7, wherein the anti-interference coating comprises a single layer structure, such as a single layer of MgF_2 .
10. The device according to any of the preceding claims, comprising a plurality of such waveguide bodies stacked on top of each other, each body comprising an anti-interference coating with different optical properties, such as wavelength specificity.
- 10 11. The device according to any of the preceding claims, wherein the anti-interference coating has an incident angle -dependent reflectance, the reflectance being at lowest for zero incident angle.
12. The device according to any of the preceding claims, wherein the coherence length of the laser rays is more than double thickness of the waveguide body.

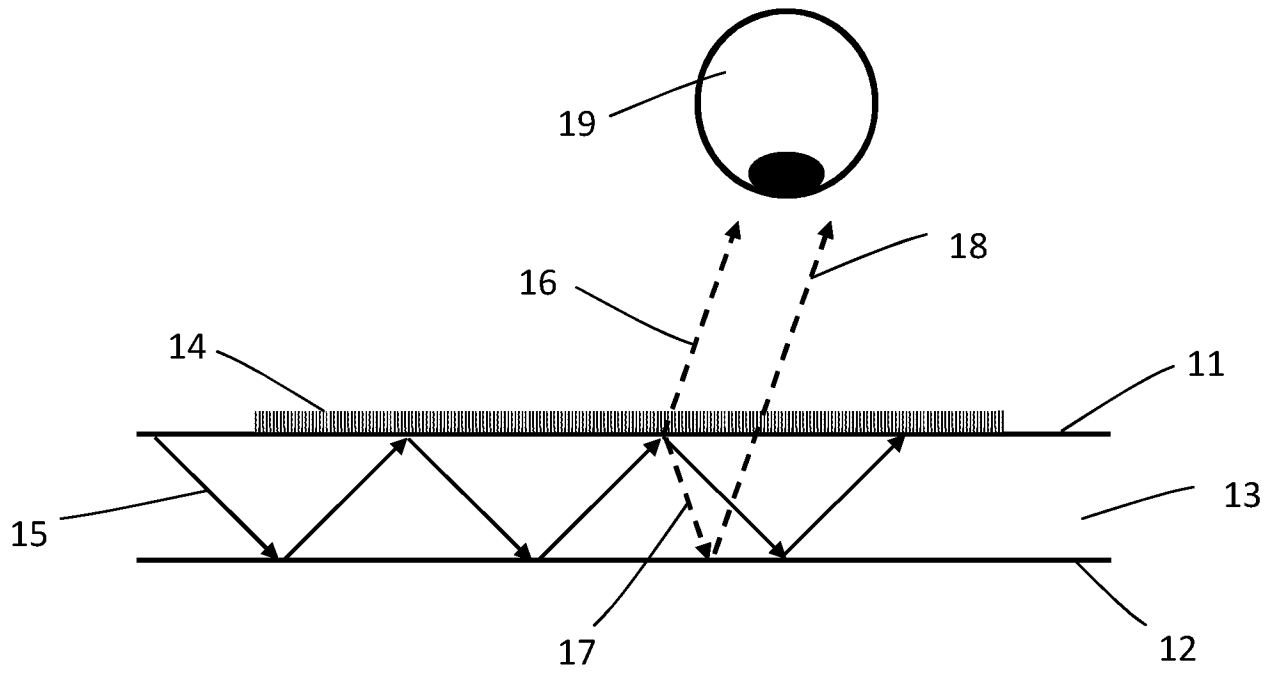

Fig. 1

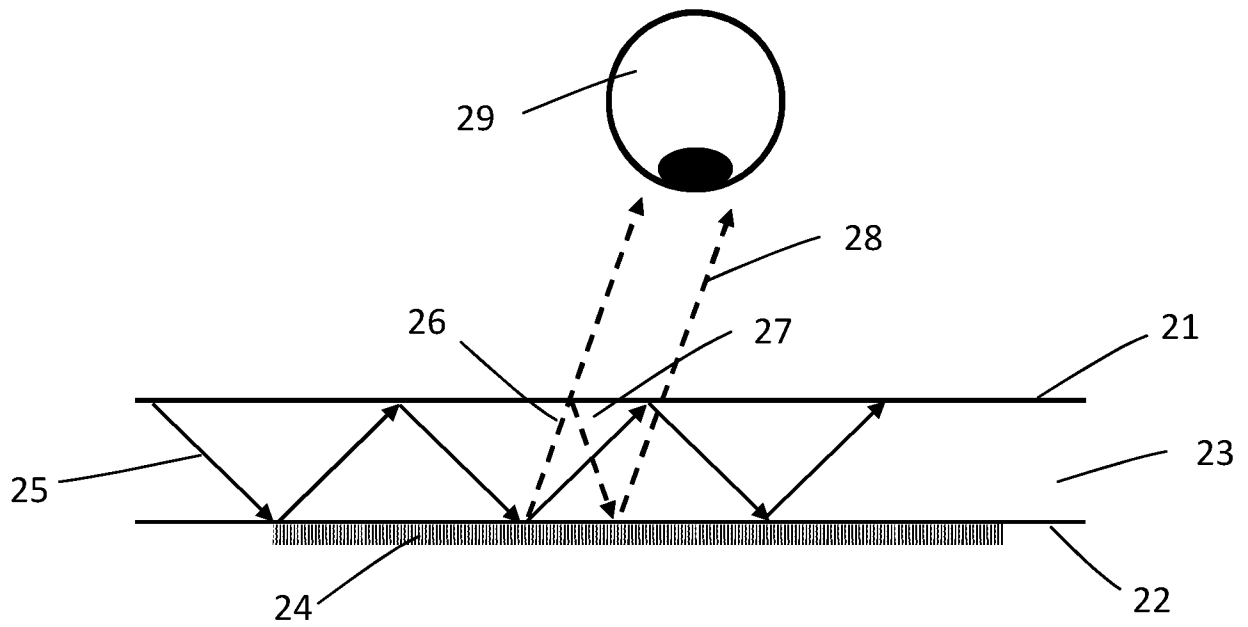

Fig. 2

2/3

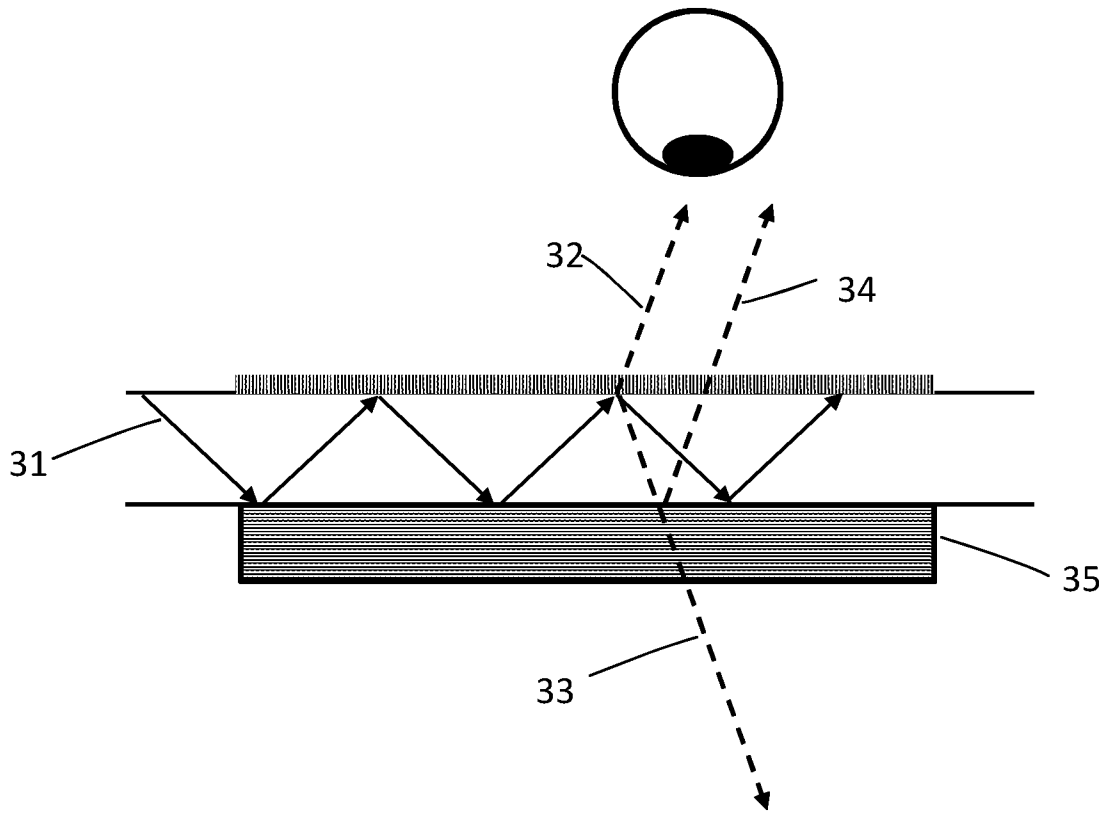

Fig. 3

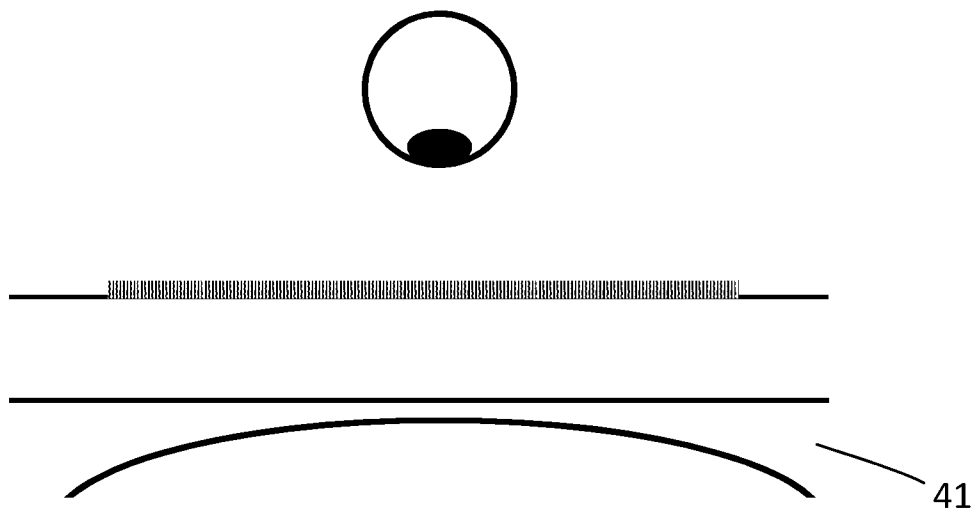

Fig. 4

3/3

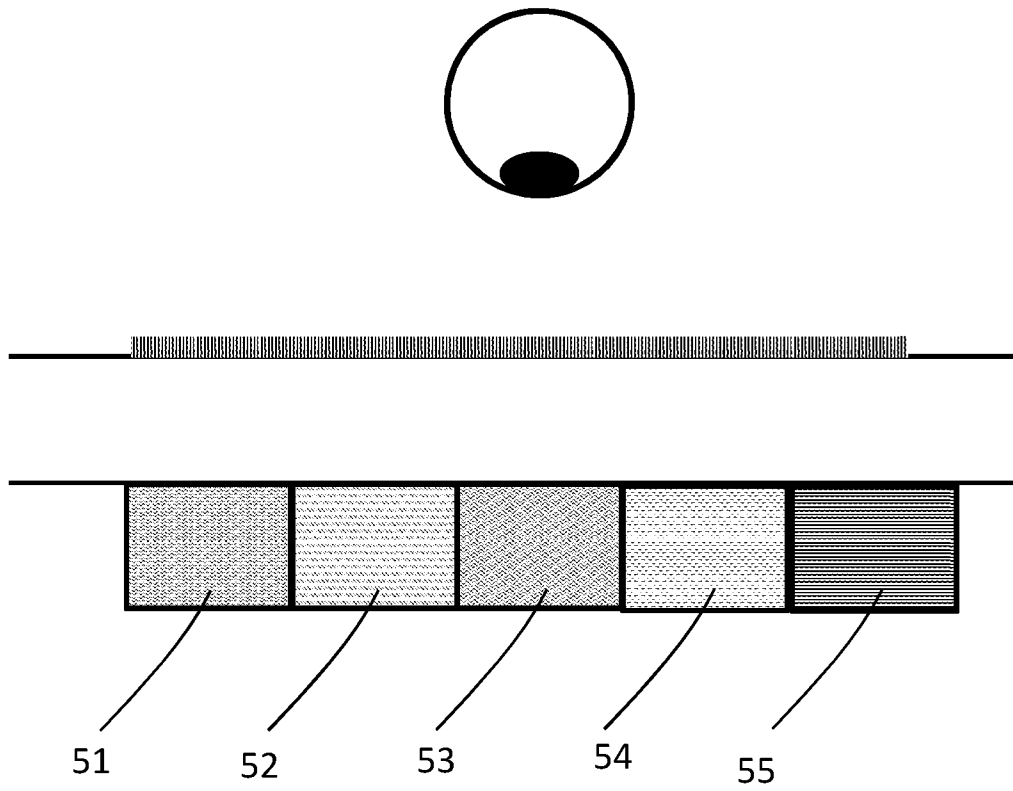

Fig. 5

INTERNATIONAL SEARCH REPORT

International application No.

PCT/FI2018/050878

A. CLASSIFICATION OF SUBJECT MATTER

See extra sheet

According to International Patent Classification (IPC) or to both national classification and IPC

B. FIELDS SEARCHED

Minimum documentation searched (classification system followed by classification symbols)

IPC: G02B

Documentation searched other than minimum documentation to the extent that such documents are included in the fields searched

FI, SE, NO, DK

Electronic data base consulted during the international search (name of data base, and, where practicable, search terms used)

EPODOC, EPO-Internal full-text databases, full-text translation databases from Asian languages, WPIAP, XP3GPP, XPAIP, XPESP, XPETSI, XPI3E, XPIEE, XPIETF, XPIOP, XPIPCOM, XPJPEG, XPMISC, XPOAC, XPRD, XPTK, BIOSIS, COMPDX, EMBASE, INSPEC, TDB, NPL

C. DOCUMENTS CONSIDERED TO BE RELEVANT

Category*	Citation of document, with indication, where appropriate, of the relevant passages	Relevant to claim No.
X	US 2017293141 A1 (SCHOWENGERDT BRIAN T [US] et al.) 12 October 2017 (12.10.2017) paragraphs [0015], [0030], [0039]-[0040], [0042], [0045], [0050], [0057]-[0059], [0070], [0072], [0078]-[0079]; Figs. 1-2, 5-8	1, 5-6, 8-12
X	US 2017131545 A1 (WALL R ANDREW [US] et al.) 11 May 2017 (11.05.2017) paragraphs [0019], [0038]-[0039], [0052], [0060], [0068]-[0070], [0075], [0081], [0089]; Figs. 1, 2, 4, 6-7	1-4
X	US 2017357101 A1 (TERVO JANI KARI TAPIO [FI] et al.) 14 December 2017 (14.12.2017) paragraphs [0029]-[0030], [0033], [0037], [0048], [0064]-[0065], [0069]-[0074]; Figs. 2, 6, 8	1

 Further documents are listed in the continuation of Box C.
 See patent family annex.

* Special categories of cited documents:	"T" later document published after the international filing date or priority date and not in conflict with the application but cited to understand the principle or theory underlying the invention
"A" document defining the general state of the art which is not considered to be of particular relevance	"X" document of particular relevance; the claimed invention cannot be considered novel or cannot be considered to involve an inventive step when the document is taken alone
"E" earlier application or patent but published on or after the international filing date	"Y" document of particular relevance; the claimed invention cannot be considered to involve an inventive step when the document is combined with one or more other such documents, such combination being obvious to a person skilled in the art
"L" document which may throw doubts on priority claim(s) or which is cited to establish the publication date of another citation or other special reason (as specified)	"&" document member of the same patent family
"O" document referring to an oral disclosure, use, exhibition or other means	
"P" document published prior to the international filing date but later than the priority date claimed	

Date of the actual completion of the international search

12 February 2019 (12.02.2019)

Date of mailing of the international search report

25 February 2019 (25.02.2019)

 Name and mailing address of the ISA/FI
 Finnish Patent and Registration Office
 FI-00091 PRH, FINLAND

Facsimile No. +358 29 509 5328

 Authorized officer
 Kristina Björknäs

Telephone No. +358 29 509 5000

INTERNATIONAL SEARCH REPORT

International application No.

PCT/FI2018/050878

C (Continuation). DOCUMENTS CONSIDERED TO BE RELEVANT

Category*	Citation of document, with indication, where appropriate, of the relevant passages	Relevant to claim No.
A	US 2017235142 A1 (WALL R ANDREW [US] et al.) 17 August 2017 (17.08.2017) paragraphs [0025]-[0026], [0035], [0044], [0046], [0052]; Figs. 1A-C, 2	1-12
A	GLYBOVSKI, S. et al. Metasurfaces: From microwaves to visible. In: Physics Reports. Elsevier [online], 2016-05-04, Vol. 634, pages 1-72, [retrieved on 2019-02-07]. Retrieved from < https://www.sciencedirect.com/science/article/pii/S0370157316300618 >, < http://dx.doi.org/10.1016/j.physrep.2016.04.004 >	1

INTERNATIONAL SEARCH REPORT
Information on Patent Family Members

International application No.
PCT/FI2018/050878

Patent document cited in search report	Publication date	Patent family members(s)	Publication date
US 2017293141 A1	12/10/2017	AU 2017246864 A1	04/10/2018
		CA 3018782 A1	12/10/2017
		CN 109073819 A	21/12/2018
		IL 261829 D0	31/10/2018
		KR 20180125600 A	23/11/2018
		WO 2017176861 A1	12/10/2017
.....			
US 2017131545 A1	11/05/2017	CN 108351089 A	31/07/2018
		EP 3374691 A1	19/09/2018
		WO 2017083159 A1	18/05/2017
.....			
US 2017357101 A1	14/12/2017	US 10025170 B2	17/07/2018
		WO 2017218245 A1	21/12/2017
.....			
US 2017235142 A1	17/08/2017	US 9891436 B2	13/02/2018
		CN 108431640 A	21/08/2018
		EP 3414603 A1	19/12/2018
		WO 2017139176 A1	17/08/2017
.....			

CLASSIFICATION OF SUBJECT MATTER

IPC
G02B 27/01 (2006.01)
G02B 27/42 (2006.01)
G02B 5/18 (2006.01)
G02B 6/00 (2006.01)
G02B 1/11 (2015.01)