

(12) **UK Patent Application** (19) **GB** (11) **2 330 426** (13) **A**

(43) Date of A Publication **21.04.1999**

(21) Application No **9812176.7**
(22) Date of Filing **05.06.1998**
(30) Priority Data
(31) **09285340** (32) **17.10.1997** (33) **JP**

(71) Applicant(s)
Mitsubishi Denki Kabushiki Kaisha
(Incorporated in Japan)
2-3 Marunouchi 2-Chome, Chiyoda-Ku,
Tokyo 100-8310, Japan

(72) Inventor(s)
Kenji Isazawa
Fujio Hitomi
Yoshihiro Maruyama

(74) Agent and/or Address for Service
J A Kemp & Co.
14 South Square, Gray's Inn, LONDON, WC1R 5LX,
United Kingdom

(51) INT CL⁶
F24F 11/00

(52) UK CL (Edition Q)
G3N NGBA NGE2 N262 N373 N374
U1S S1967

(56) Documents Cited
GB 2246453 A EP 0543622 A2 JP 620162834 A

(58) Field of Search
UK CL (Edition P) **G3N NGA9 NGBA NGBA1 NGBA2A**
NGBA3 NGBB3 NGE2
INT CL⁶ **F24F 11/00**
Online: **WPI, JAPIO**

(54) Abstract Title
Air conditioning system

(57) For cost effectiveness, the capacity of outdoor unit 1 is less than the total capacity of indoor units 2. When there are requests for operation from the remote controllers 3 of the indoor units, means 8a calculates the capacity of the demand, means 8c determines whether this capacity is within the capacity of outdoor unit 3 and, if not, means 8d identifies which remote controller is of lowest priority, eg lowest demand, and instructs commanding unit 8e to exclude that remote controller's request. This process repeats until the demand can be met, at which time the operation is started. This is repeated after a period of time as some requests may be terminated. More sophisticated prioritisation of the indoor units may include allocation of the units into blocks and combinations of blocks and the setting of operational time zones.

FIG. 1

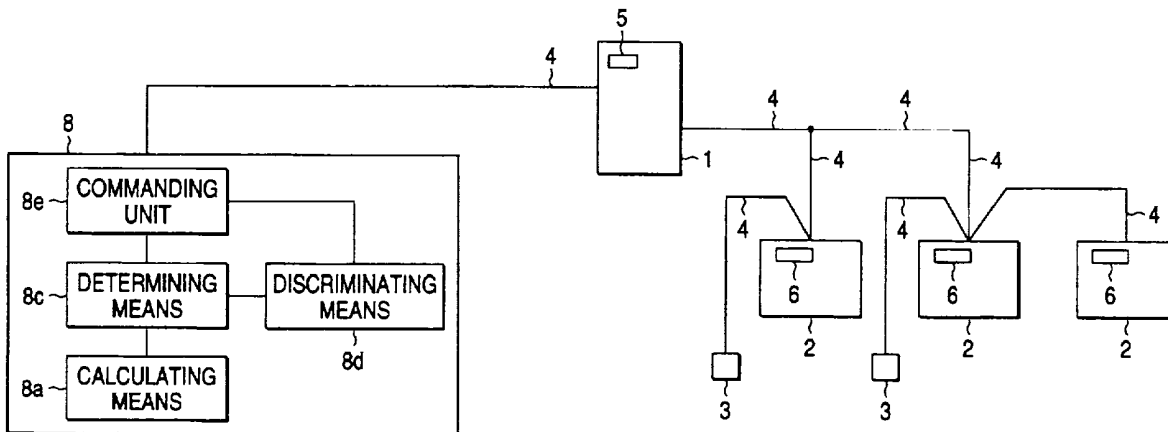

GB 2 330 426 A

FIG. 1

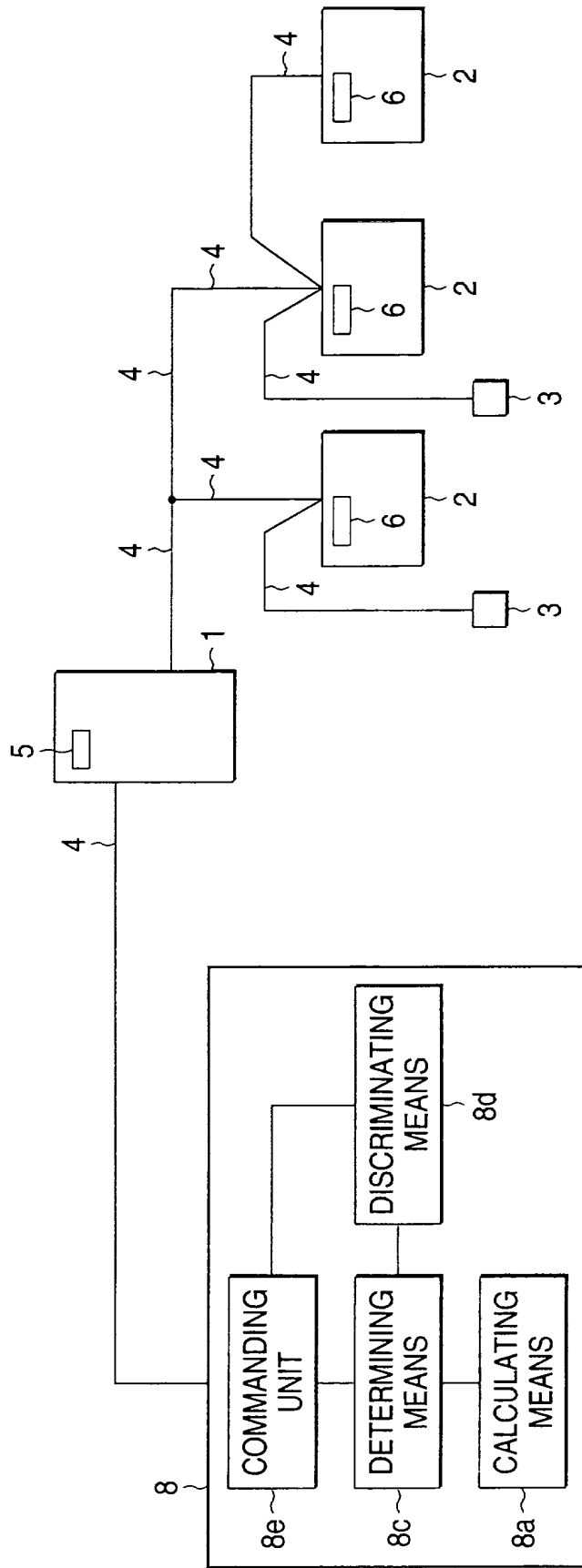

FIG. 2

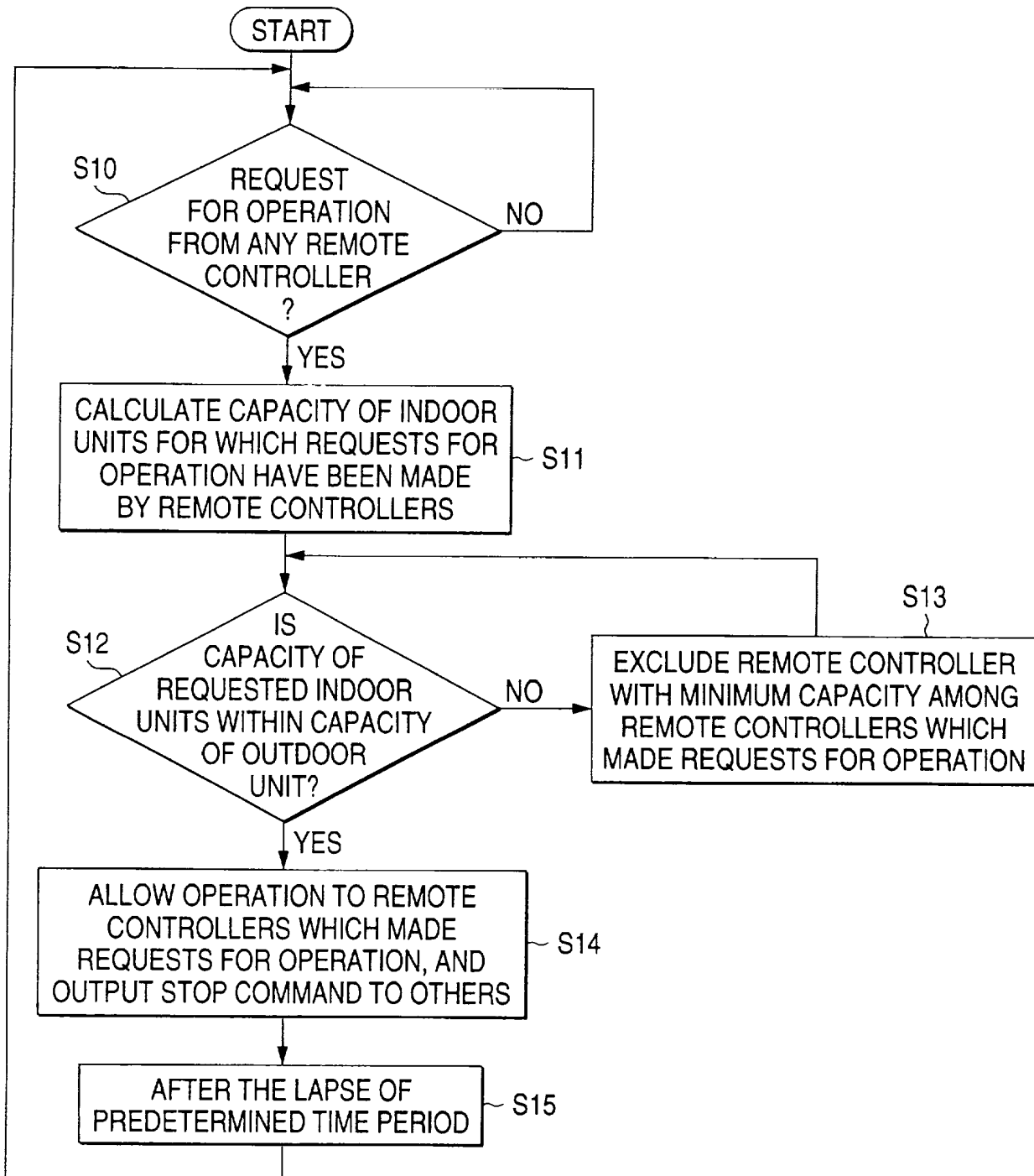

FIG. 3

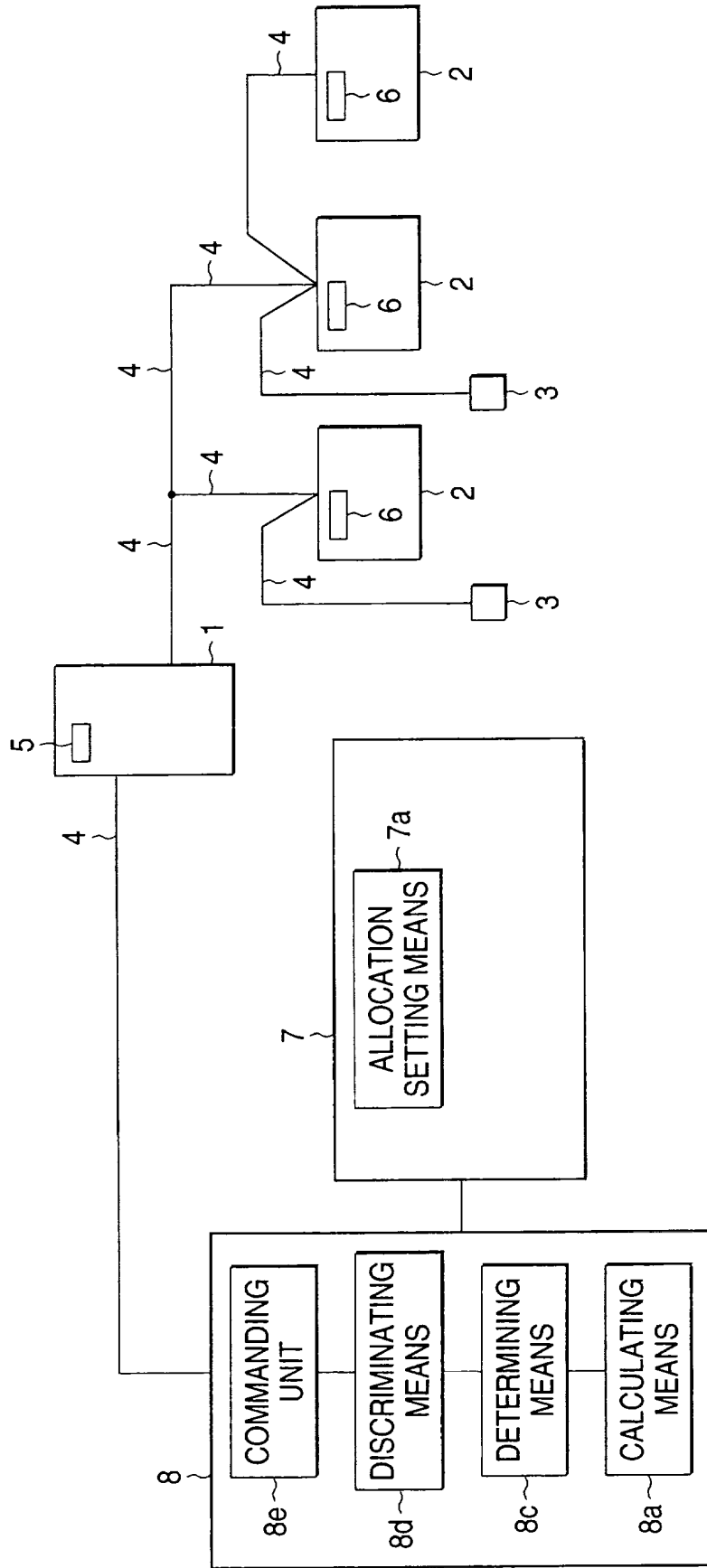

FIG. 4

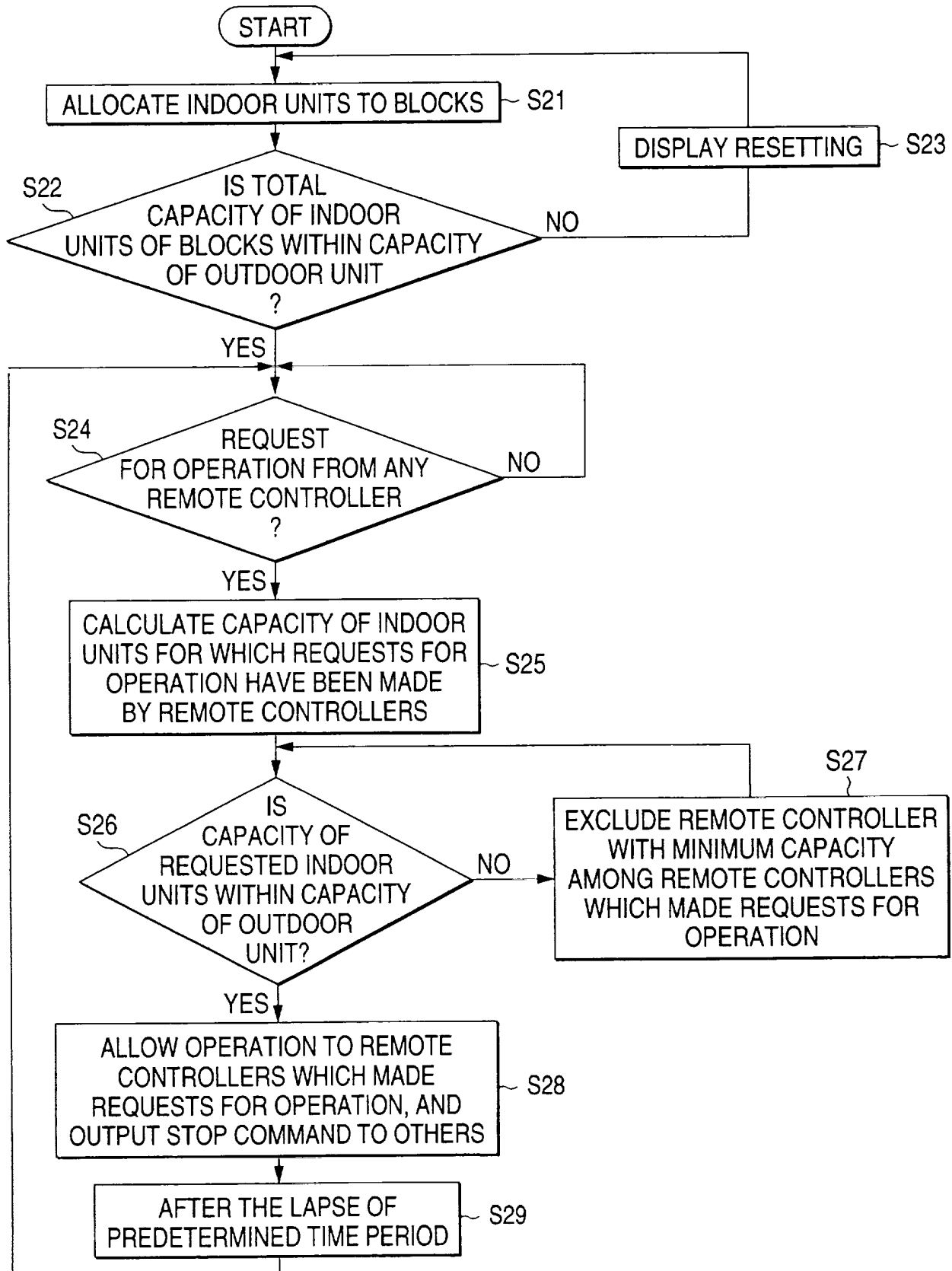

FIG. 5

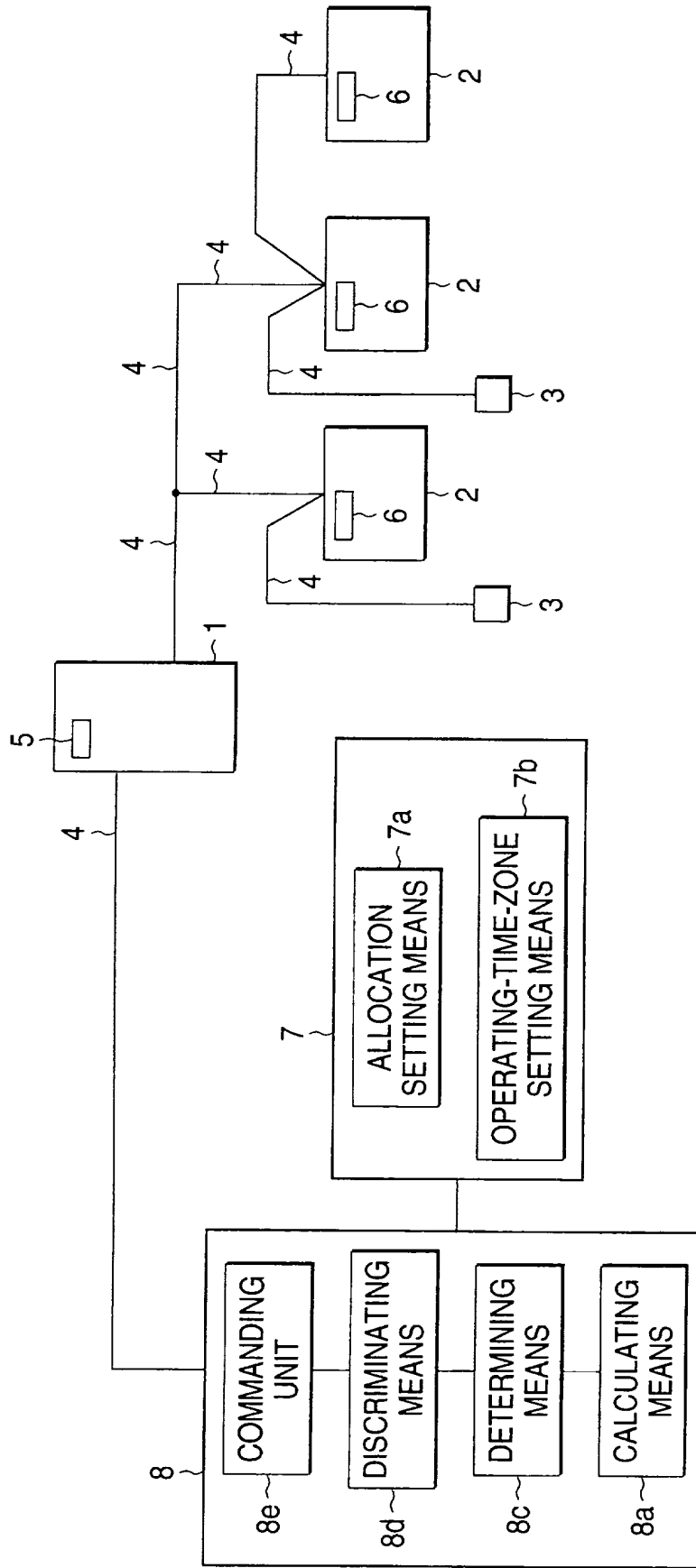

FIG. 6

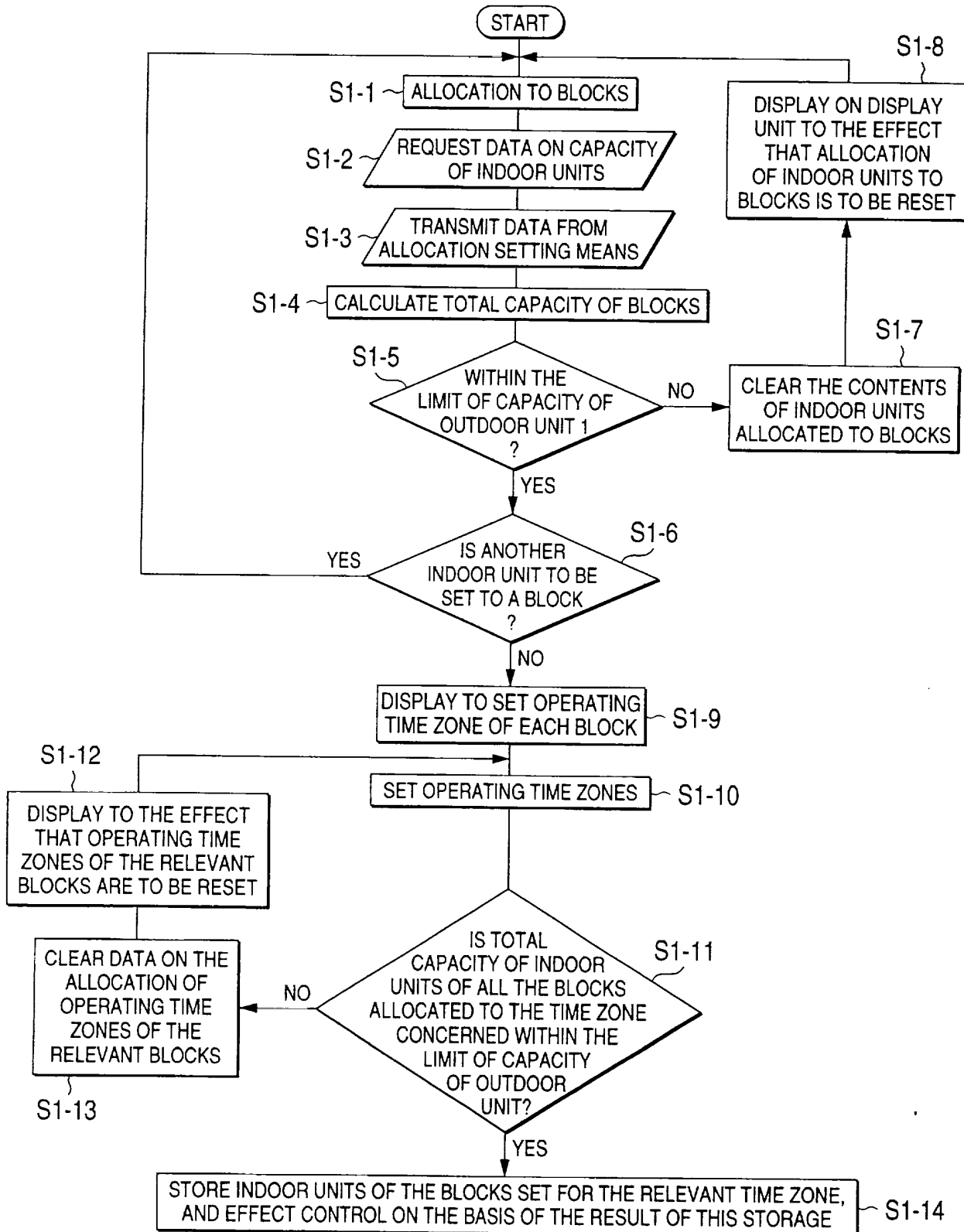

FIG. 7

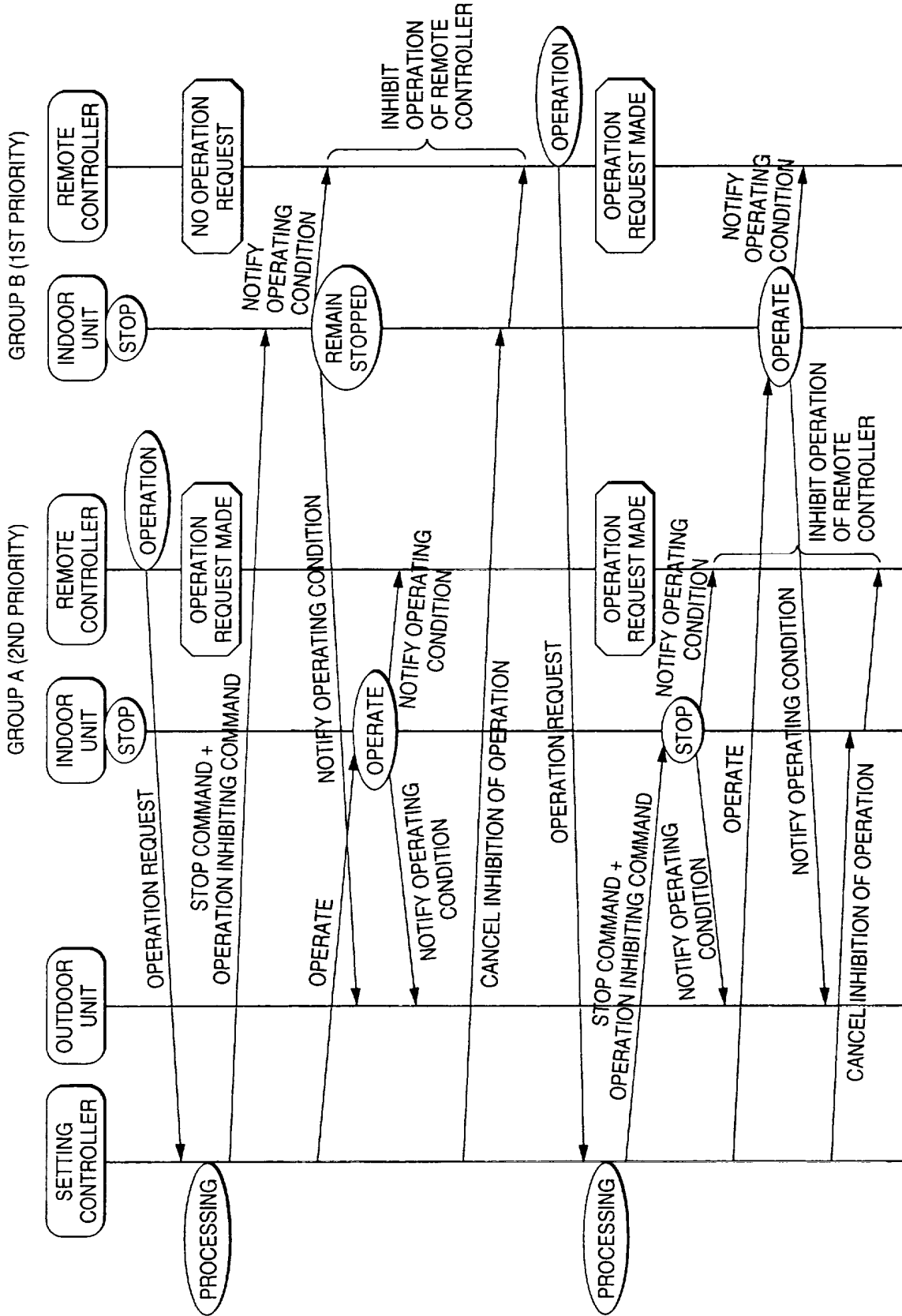

FIG. 8

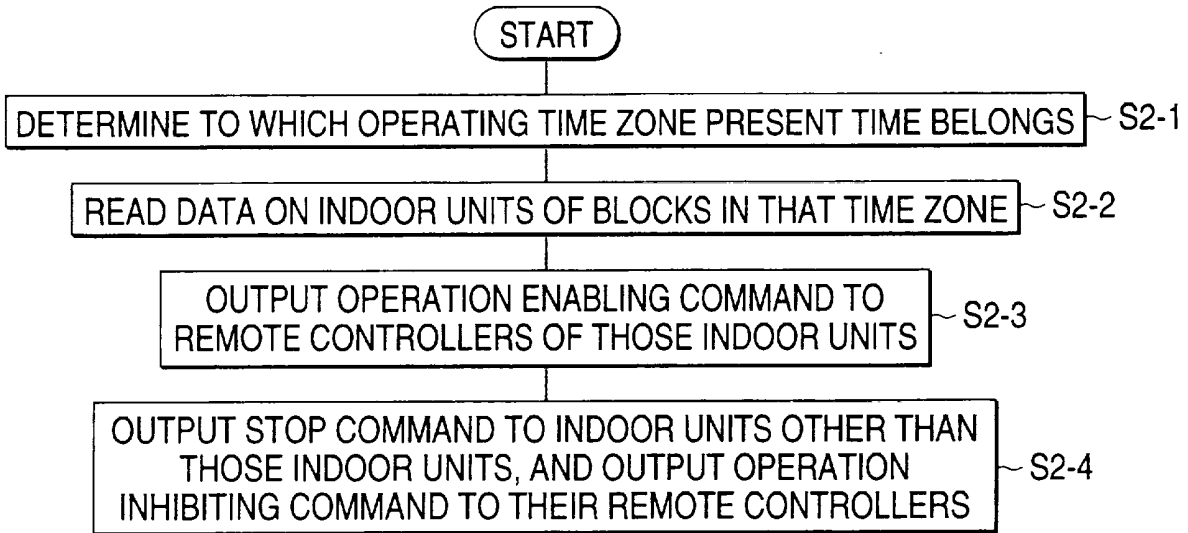

FIG. 9

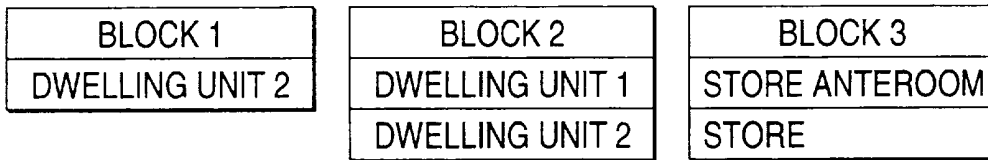

FIG. 10

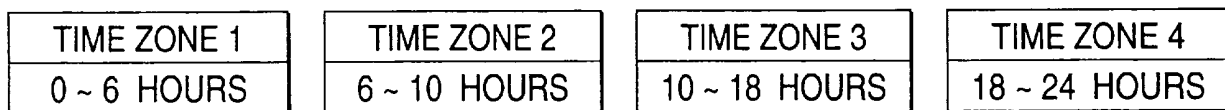

FIG. 11

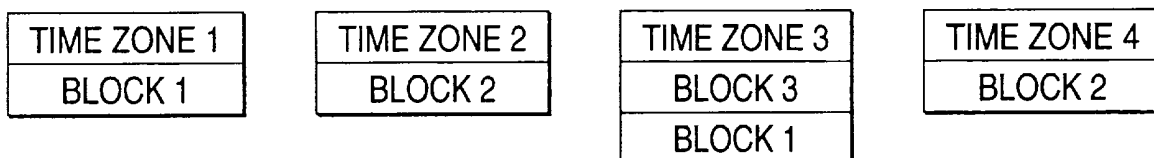

FIG. 12

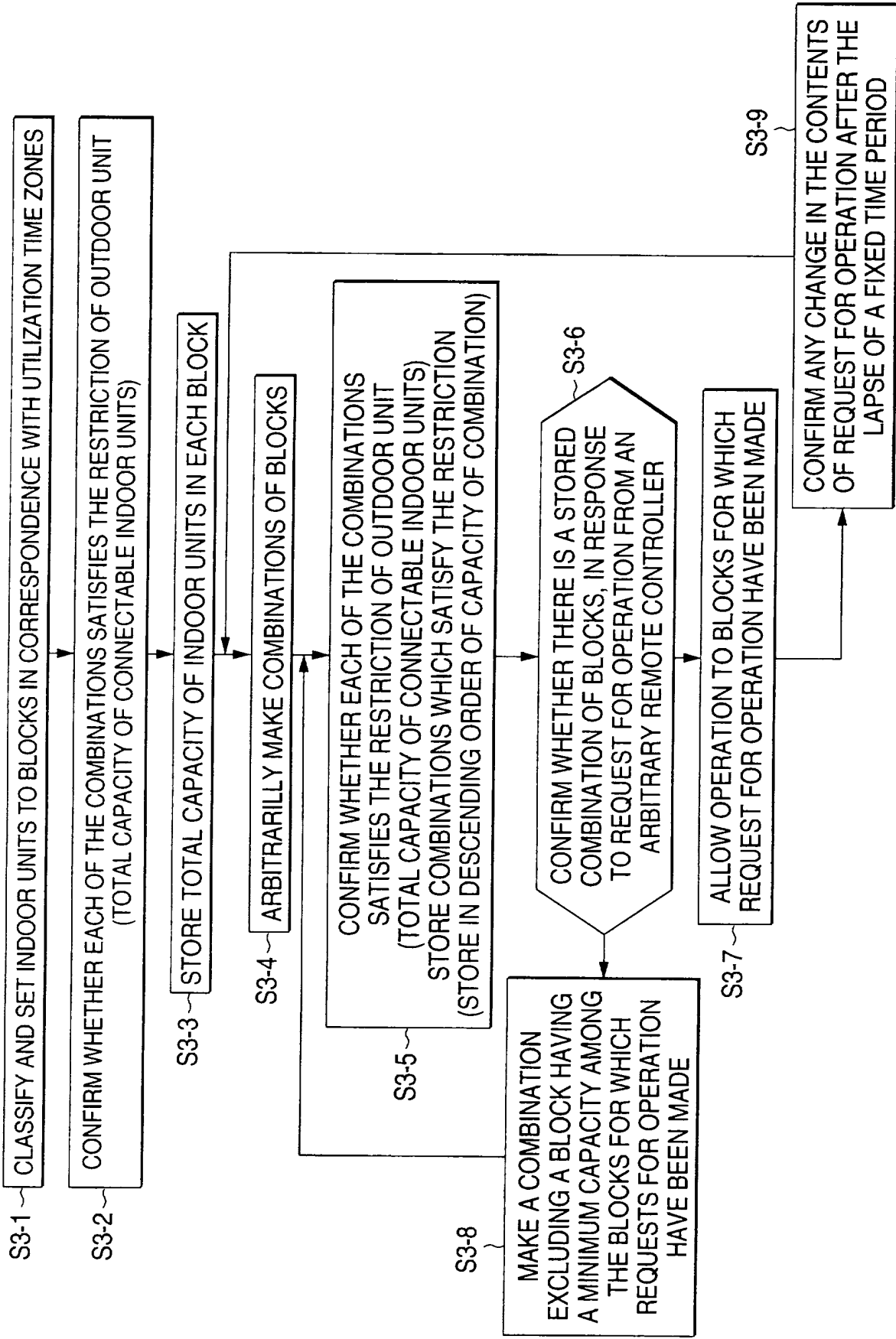

FIG. 13

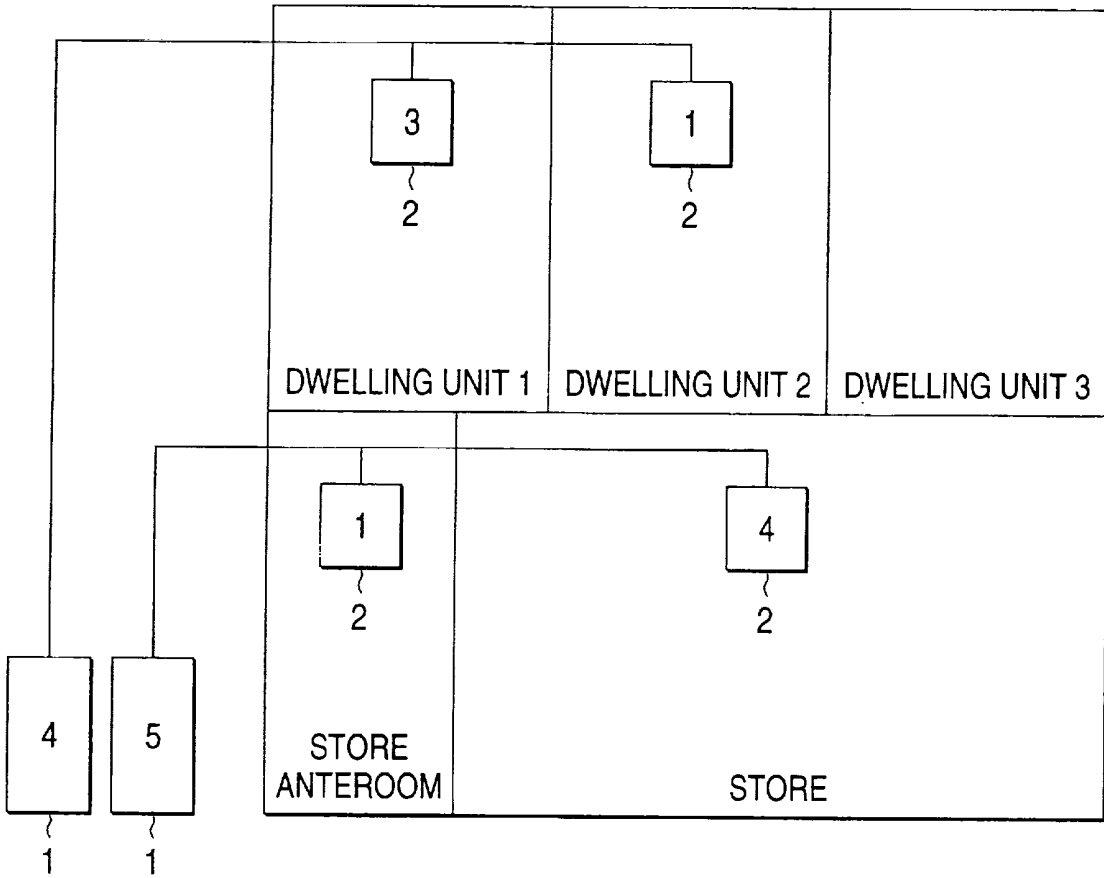

FIG. 14

	TIME ZONE 1 0 ~ 6 HOURS	TIME ZONE 2 6 ~ 10 HOURS	TIME ZONE 3 10 ~ 18 HOURS	TIME ZONE 4 18 ~ 24 HOURS	MAXIMUM LOAD OF EACH ROOM
DWELLING UNIT 1	0	3	0	3	3
DWELLING UNIT 2	1	1	0	1	1
STORE ANTEROOM	0	0	1	0	1
STORE	0	0	4	0	4
TOTAL AIR-CONDITIONING LOAD	1	4	5	4	9

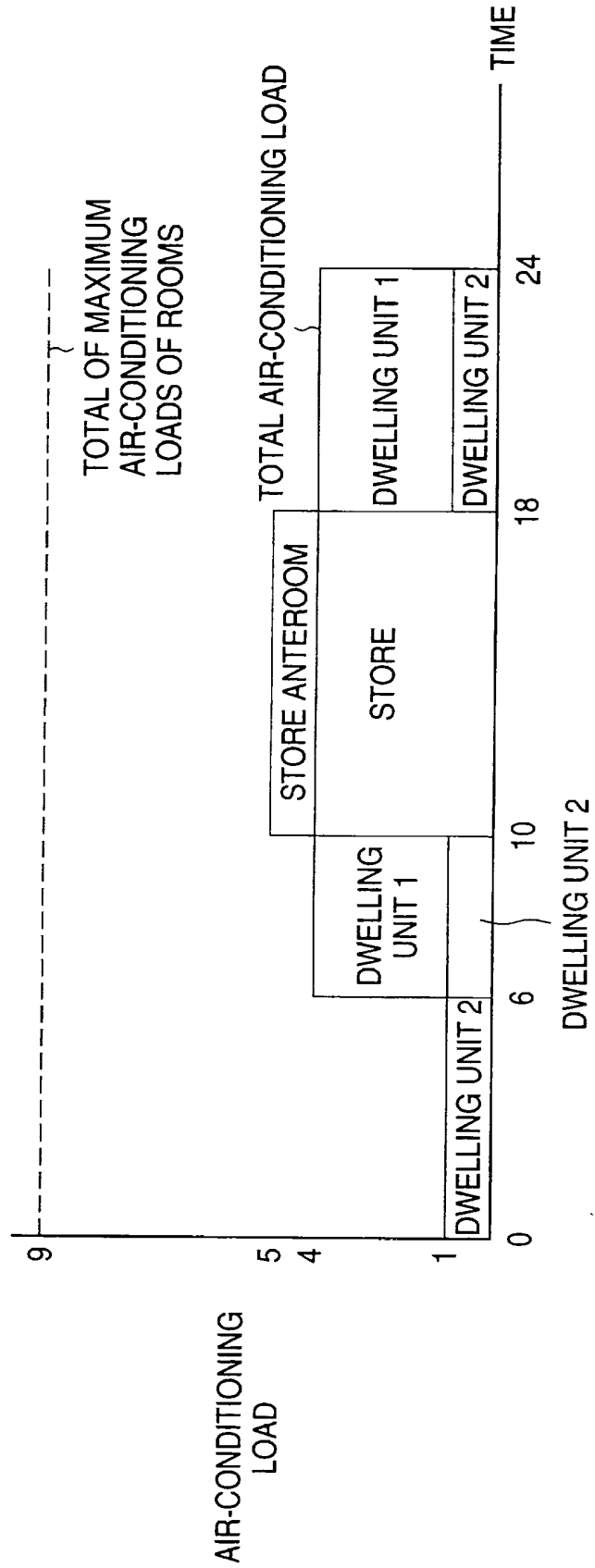

FIG. 15

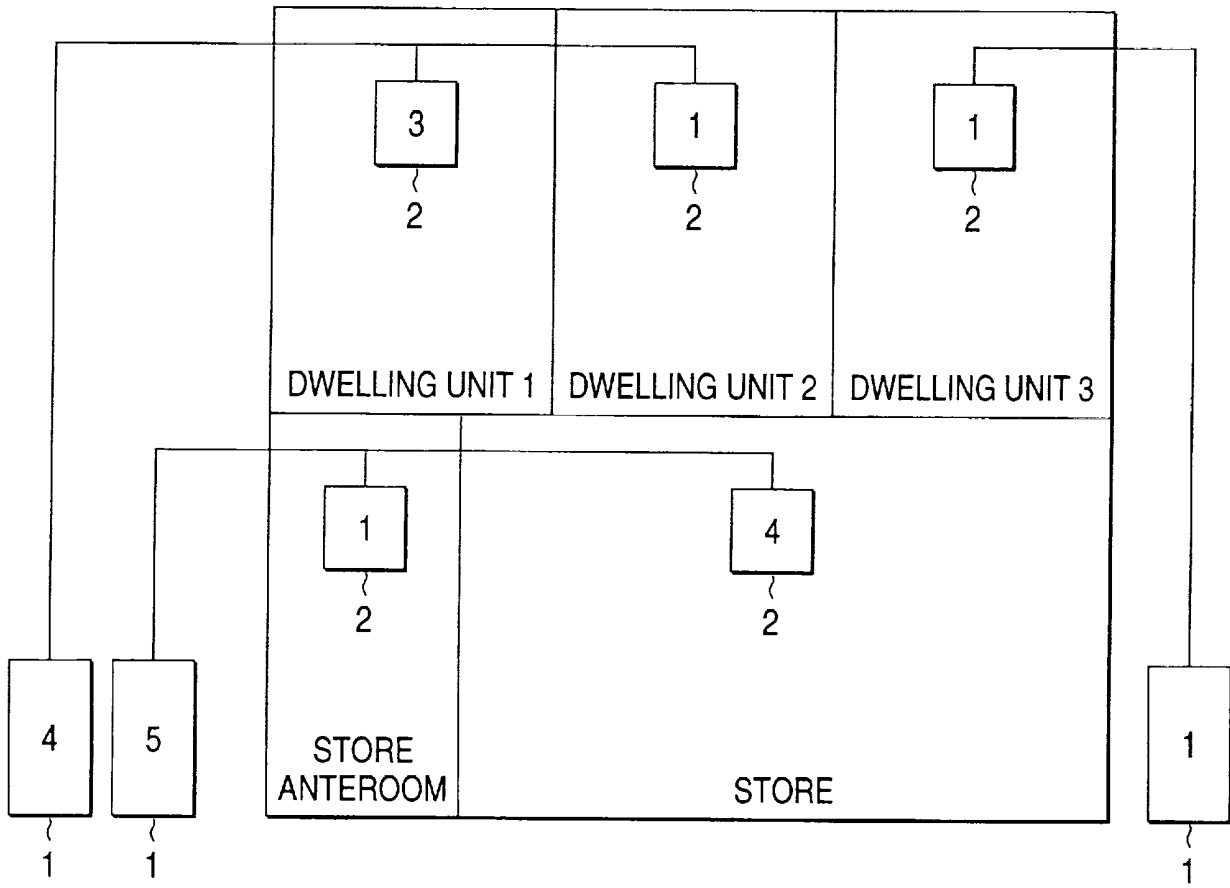
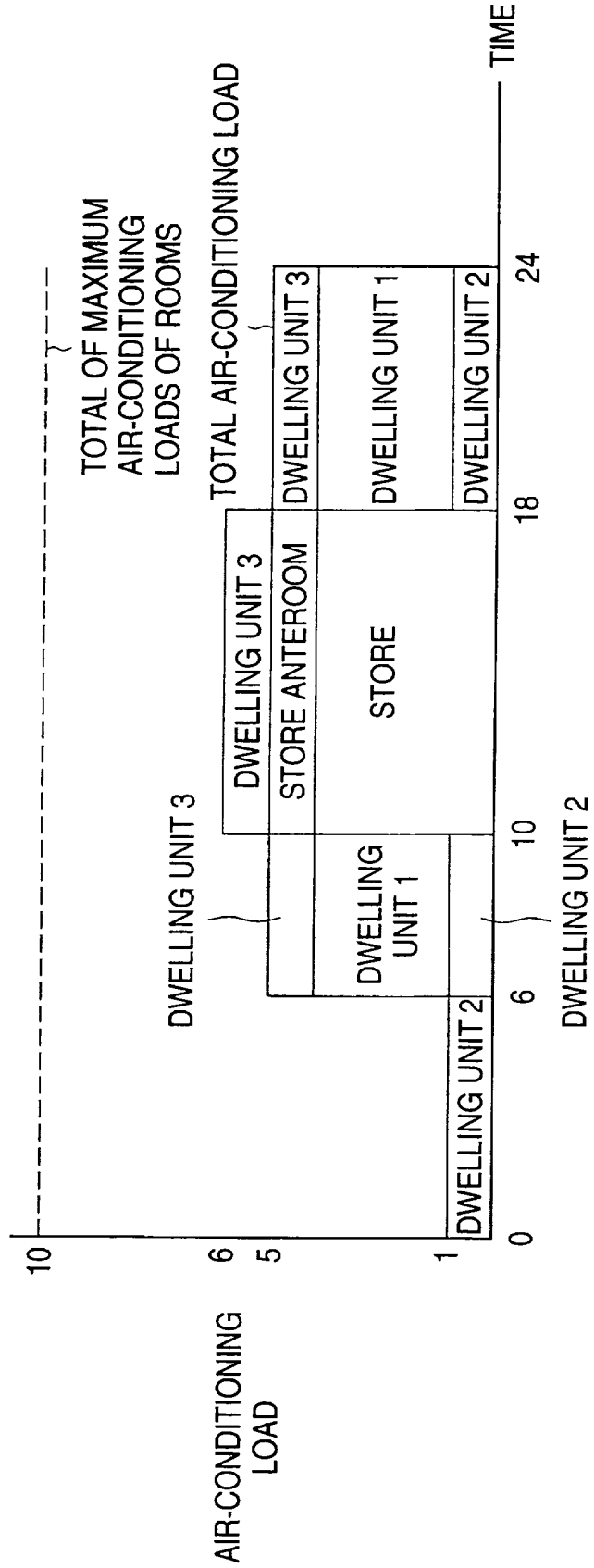

FIG. 16

	TIME ZONE 1 0 ~ 6 HOURS	TIME ZONE 2 6 ~ 10 HOURS	TIME ZONE 3 10 ~ 18 HOURS	TIME ZONE 4 18 ~ 24 HOURS	MAXIMUM LOAD OF EACH ROOM
DWELLING UNIT 1	0	3	0	3	3
DWELLING UNIT 2	1	1	0	1	1
DWELLING UNIT 3	0	1	1	1	1
STORE ANTEROOM	0	0	1	0	1
STORE	0	0	4	0	4
TOTAL AIR-CONDITIONING LOAD	1	5	6	5	10



AIR CONDITIONING SYSTEM

The present invention relates to an air conditioning system having a plurality of indoor units which are connected to an outdoor unit and whose total capacity is greater than the capacity of the outdoor unit, wherein the total operating capacity of the connected indoor units is arranged to fall within the capacity of the outdoor unit.

In a conventional air conditioning system in which a plurality of indoor units are connected to a outdoor unit, the capacity of the outdoor unit has been so designed that all the indoor units can be operated despite the fact that the total actual operating capacity of the indoor units is fairly small with respect to the capacity of the outdoor unit, as shown in Fig. 13. Namely, the design has been made such that the capacity of the outdoor unit and the total capacity of the indoor units become equal.

Since the design is based on such a standpoint, when it is necessary to increase the number of units (capacity) of indoor units particularly at the time of such as the remodeling of the store, it has been the conventional practice to additionally increase an outdoor unit having a capacity

commensurate with the total load (total required capacity) of the increased number of units (capacity) of the indoor units.

Next, a description will be given of a specific example of such a case with reference to Fig. 13. It should be noted that this diagram is a schematic diagram of a dwelling house combined with a store. In the drawing, the numeral in each square frame denotes the required air-conditioning load (capacity) of each room.

As can be seen from this drawing, since the store section, which is a place of work for people, is occupied by people only during the daytime, air conditioning of the store section is effected only during the daytime, and is not effected during the nighttime. On the other hand, as for the dwelling section, which is a place of rest for people, it is the general practice to effect not much air conditioning during the daytime and effect air conditioning during the nighttime.

Accordingly, the change in the air-conditioning load in such a dwelling house combined with a store is shown in Fig. 14, for example. As shown in this drawing, despite the fact that the total capacity of the air-conditioning load is 5 or less in any time period, the conventional practice has been such that, as shown in Fig. 13, capacities of outdoor units corresponding to the respective capacities of indoor units are respectively selected, and outdoor units having a capacity of 4 and a capacity of 5, i.e., two outdoor units in total, are installed, or the capacities of indoor units are simply added

together, and the capacity of an outdoor unit corresponding to the added total capacity of 9 is selected, and that outdoor unit is installed for operation.

It should be noted that the numeral in a rectangular frame for each outdoor unit 1 in the drawing denotes the capacity of the outdoor unit, and the numeral in the square frame for each indoor unit 2 denotes the capacity of the indoor unit.

In addition, each line connecting the outdoor unit 1 and the indoor units 2 shows the relationship of connection of a refrigerant circuit.

It should be noted that these numerals and the meaning of the lines apply to the other drawings as well.

In addition, in a case where an arrangement is provided as shown in Fig. 15 in which a dwelling unit 3 such as a vacant room shown in Fig. 13 is newly air conditioned, despite the fact that the total capacity of the air-conditioning load is 6 or less in any time period, the conventional practice has been such that an outdoor unit 1 and an indoor unit 2 are newly installed as shown in Fig. 15 to air condition the dwelling space.

As has been described above, with the conventional air conditioning system, since the capacities of the outdoor units are selected so that the total indoor units can be operated, there have been problems in that the operation is effected in a state in which the capacities of the outdoor units are

excessive with respect to the capacities of the indoor units which are actually operated, so that the amount of refrigerant charged becomes large, wasteful energy is consumed, and installation cost becomes relatively high.

The present invention has been devised to overcome the above-described problems, and its object is to obtain an economical, easy-to-use, and highly reliable air conditioning system which excels in energy efficiency by making efficient use of the capacity of the outdoor unit and is capable of performing stable operation in response to requests for operation of the respective indoor units.

In accordance with the present invention, there is provided an air conditioning system comprising: an outdoor unit; a plurality of indoor units which are connected to the outdoor unit and whose total capacity is greater than the capacity of the outdoor unit; remote controllers which are operated for respectively controlling operating conditions of the plurality of indoor units; and operation controlling means for controlling the operating conditions of the plurality of indoor units on the basis of results of operation of the remote controllers, wherein the operation controlling means includes calculating means for calculating a total capacity of the indoor units whose operation has been requested by the remote controllers, determining means for determining on the basis of

a result of calculation by the calculating means whether or not the total capacity of the indoor units whose operation has been requested is within the capacity of the outdoor unit, and control commanding means for controlling on the basis of the determination the operating conditions of the indoor units whose operation has been requested, when the total capacity of the indoor units is within the capacity of the outdoor unit, in response to the result of operation of each of the remote controllers.

In addition, there is provided an air conditioning system comprising: an outdoor unit; a plurality of indoor units which are connected to the outdoor unit and whose total capacity is greater than the capacity of the outdoor unit; remote controllers which are operated for respectively controlling operating conditions of the plurality of indoor units; and operation controlling means for controlling the operating conditions of the plurality of indoor units on the basis of results of operation of the remote controllers, wherein the operation controlling means includes calculating means for calculating a total capacity of the indoor units whose operation has been requested by the remote controllers, determining means for determining on the basis of a result of calculation by the calculating means whether or not the total capacity of the indoor units whose operation has been requested is within the capacity of the outdoor unit, discriminating means for discriminating on the basis of a result of the

determination priorities in operation of the indoor units whose operation has been requested when the total capacity of the indoor units has exceeded the capacity of the outdoor unit, and control commanding means for controlling on the basis of the discrimination by the discriminating means the operating conditions of the indoor units whose operation has been requested, in response to the result of operation of each of the remote controllers.

In addition, there is provided an air conditioning system comprising: an outdoor unit; a plurality of indoor units which are connected to the outdoor unit and whose total capacity is greater than the capacity of the outdoor unit; allocation setting means for setting the allocation of the plurality of indoor units to blocks in correspondence with conditions of utilization of rooms where the indoor units are respectively installed; remote controllers which are operated for respectively controlling operating conditions of the blocks on the basis of a result of allocation by the allocation setting means; and operation controlling means for controlling the operating conditions of the blocks on the basis of results of operation of the remote controllers, wherein the operation controlling means includes calculating means for calculating a total capacity of the indoor units of the blocks for which operation has been requested by the remote controllers, determining means for determining on the basis of a result of calculation by the calculating means whether or not the total

capacity of the indoor units is within the capacity of the outdoor unit, and operation controlling means for controlling on the basis of the determination the operating conditions of the blocks for which operation has been requested, when the total capacity of the indoor units is within the capacity of the outdoor unit, in response to the result of operation of each of the remote controllers.

In addition, there is provided an air conditioning system comprising: an outdoor unit; a plurality of indoor units which are connected to the outdoor unit and whose total capacity is greater than the capacity of the outdoor unit; allocation setting means for setting the allocation of the plurality of indoor units to blocks in correspondence with conditions of utilization of rooms where the indoor units are respectively installed; remote controllers which are operated for respectively controlling operating conditions of the blocks on the basis of a result of allocation by the allocation setting means; and operation controlling means for controlling the operating conditions of the blocks on the basis of results of operation of the remote controllers, wherein the operation controlling means includes calculating means for calculating a total capacity of the indoor units of the blocks whose operation has been requested by the remote controllers, determining means for determining on the basis of a result of calculation by the calculating means whether or not the total capacity of the indoor units is within the capacity of the

outdoor unit, discriminating means for discriminating on the basis of a result of the determination priorities in operation of the blocks for which operation has been requested when the total capacity of the indoor units has exceeded the capacity of the outdoor unit, and operation controlling means for controlling on the basis of the discrimination by the discriminating means the operating conditions of the blocks for which operation has been requested, in response to the result of operation of each of the remote controllers.

In addition, there is provided an air conditioning system comprising: an outdoor unit; a plurality of indoor units which are connected to the outdoor unit and whose total capacity is greater than the capacity of the outdoor unit; remote controllers which are operated for respectively controlling operating conditions of the plurality of indoor units; operating-time-zone setting means for setting an operating time zone of each of the remote controllers; and operation controlling means for controlling on the basis a result of setting by the operating-time-zone setting means the operating conditions of the indoor units in response to results of operation of the remote controllers, wherein the operation controlling means includes calculating means for calculating a total capacity of the indoor units for the operating time zone set by the operating-time-zone setting means, determining means for determining on the basis of a result of calculation by the calculating means whether or not the total capacity of the

indoor units for the operating time zone is within the capacity of the outdoor unit, and control commanding means for controlling on the basis of the determination the operating conditions of the indoor units when the total capacity of the indoor units is within the capacity of the outdoor unit, in accordance with the result of setting by the operating-time-zone setting means in response to the result of operation of each of the remote controllers.

In addition, there is provided an air conditioning system comprising: an outdoor unit; a plurality of indoor units which are connected to the outdoor unit and whose total capacity is greater than the capacity of the outdoor unit; remote controllers which are operated for respectively controlling operating conditions of the plurality of indoor units; allocation setting means for setting the allocation of the remote controllers to blocks in correspondence with conditions of utilization of rooms where the indoor units are respectively installed; operating-time-zone setting means for setting an operating time zone of each of the blocks on the basis of a result of allocation by the allocation setting means; and operation controlling means for controlling on the basis a result of setting by the operating-time-zone setting means the operating conditions of the blocks in response to results of operation of the remote controllers, wherein the operation controlling means includes calculating means for calculating a total capacity of the indoor units for each

operating time zone of the blocks set by the operating-time-zone setting means, determining means for determining on the basis of a result of calculation by the calculating means whether or not the total capacity of the indoor units for the operating time zone is within the capacity of the outdoor unit, and control commanding means for controlling on the basis of the determination the operating conditions of the indoor units of the blocks when the total capacity of the indoor units is within the capacity of the outdoor unit, in accordance with the result of setting by the operating-time-zone setting means in response to the result of operation of each of the remote controllers.

In addition, the priorities of operation by the remote controllers are based on one of the descending order of magnitude of the total capacity of the indoor units and the descending order in the number of indoor units.

In addition, the control commanding means controls the operating conditions of the indoor units in response to the result of operation of each remote controller on the basis of the result from the determining means or the discriminating means, and the control commanding means transmits an operation inhibiting signal to the remote controllers other than the remote controllers concerned so as to stop the operation of the remote controllers other than the remote controllers concerned for a predetermined time period.

In addition, each of the remote controllers displays the operation inhibiting signal from the control commanding means on a display unit.

The invention will be further described by way of non-limitative example with reference to the accompanying drawings, in which:

Fig. 1 is a schematic diagram of an air conditioning system in accordance with a first embodiment of the present invention;

Fig. 2 is a flowchart of the air conditioning system in accordance with the first embodiment of the present invention;

Fig. 3 is a schematic diagram of an air conditioning system in accordance with a second embodiment of the present invention;

Fig. 4 is a flowchart of the air conditioning system in accordance with the second embodiment of the present invention;

Fig. 5 is a schematic diagram of an air conditioning system in accordance with a third embodiment of the present invention;

Fig. 6 is a flowchart of the air conditioning system in accordance with the third embodiment of the present invention;

Fig. 7 is a schematic diagram illustrating a control system in accordance with the first, second, and third embodiments of the present invention;

Fig. 8 is a flowchart of the air conditioning system in accordance with the third embodiment of the present invention;

Fig. 9 is a diagram illustrating an example of allocation in the air conditioning system in accordance with the third embodiment of the present invention;

Fig. 10 is a diagram illustrating an example of the setting of time zones in the air conditioning system in accordance with the third embodiment of the present invention;

Fig. 11 is a diagram illustrating an example of allocation of blocks to time zones in the air conditioning system in accordance with the third embodiment of the present invention;

Fig. 12 is a flowchart of the air conditioning system in accordance with the third embodiment of the present invention;

Fig. 13 is a schematic diagram of layout of a conventional air conditioning system;

Fig. 14 is a table and a diagram illustrating the air-conditioning load and changes in the air-conditioning load by time zone in the conventional air conditioning system;

Fig. 15 is a remodeling layout diagram of the conventional air conditioning system; and

Fig. 16 is a table and a diagram illustrating the air-conditioning load and changes in the air-conditioning load by time zone in the conventional air conditioning system after remodeling.

Now, a description will be given in more detail of preferred embodiments of the invention with reference to the accompanying drawings.

(First Embodiment)

Referring now to Figs. 1, 2, and 7, a description will be given of a first embodiment.

Fig. 1 is a schematic diagram illustrating a system of air conditioners in accordance with the first embodiment.

In Fig. 1, reference numeral 1 denotes an outdoor unit; 2, a plurality of indoor units whose total capacity is greater than the capacity of the outdoor unit; 3, remote controllers respectively connected to the plurality of indoor units 2 to control the operating conditions of the indoor units 2; 4, transmission lines provided for connecting the outdoor unit 1, the indoor units 2, the remote controllers 3, and an operation controlling means 8 which will be described later, and for transmitting bidirectional signals; 5, a controller for the outdoor unit for controlling the operation of the outdoor unit 1; and 6, controllers for the respective indoor units for controlling the operation of the indoor units on the basis of signals from the remote controllers 3.

In addition, numeral 8 denotes the operation controlling means, and this operation controlling means 8 is provided with the following: a calculating means 8a for calculating the total capacity of the indoor units whose operation has been requested by the respective remote

controllers 3; a determining means 8c for determining whether or not the total capacity of the indoor units, the operation of which has been requested by the respective remote controllers 3, is within the capacity of the outdoor unit 2; and a control commanding means 8e for controlling on the basis of the result of the determination the operating conditions of the indoor units 2 whose operation has been requested, when the total capacity of the indoor units is within the capacity of the outdoor unit, in response to the result of operation of each of the remote controllers.

It should be noted that if the total capacity of the indoor units exceeds the capacity of the outdoor unit in the result of the aforementioned determination, a discriminating means 8d of the operation controlling means 8 discriminates priorities in the operation of the indoor units whose operation has been requested by the remote controllers 3, and on the basis of the result of this discrimination the discriminating means 8d discriminates the priorities in the operation of the indoor units until the total capacity of the indoor units falls within the capacity of the outdoor unit, as will be described later. Accordingly, on the basis of the result of that discrimination, the capacity-control commanding means 8e controls the operating conditions of the indoor units 2 whose operation has been requested by the remote controllers, in response to the result of operation of each remote controller.

In addition, with this air conditioning system, the outdoor unit 1 is naturally provided with a compressor, a four-way valve for effecting a changeover between cooling and heating, an outdoor-side heat exchanger, and an accumulator, and each indoor unit 2 is provided with an indoor-side heat exchanger, a pressure reducing device, and the like, although they are not shown.

It should be noted that the four-way valve of the outdoor unit 1 and the indoor-side heat exchanger, as well as the outdoor-side heat exchanger and the pressure reducing device of each indoor unit 2, are respectively connected by unillustrated refrigerant pipes, and the outdoor unit 1 and the respective indoor units 2 are connected by these connecting pipes, thereby forming a refrigerant cycle.

Next, referring to Fig. 2, a description will be given of the operation in accordance with this first embodiment.

First, if a user operates the remote controller of a certain indoor unit 2 among the indoor units 2, the result of operation of the remote controller thus operated (request for operation) is transmitted to the operation controlling means 8 via the transmission line 4.

Next, in the operation controlling means 8, in response to the result of operation of that remote controller 3, the calculating means 8a calculates the total capacity of the indoor units whose operation has been requested by the respective remote controllers, on the basis of values of

capacities of the indoor units registered in advance for the remote controllers.

Next, on the basis of the result of calculation by the calculating means 8a, the determining means 8c determines whether or not the total capacity of the indoor units whose operation has been requested by the remote controllers is within the capacity of the outdoor unit.

If the total capacity of the indoor units 2 is within the capacity of the outdoor unit 1 in the result of this determination, the control commanding means 8e controls the operating conditions of the indoor units whose operation has been requested by the remote controllers, in response to the result of operation of each remote controller.

On the other hand, if the total capacity of the indoor units 2 exceeds the capacity of the outdoor unit 1 in the result of the aforementioned determination, by checking the priorities in the operation of the indoor units whose operation has been requested by the remote controllers 3, the discriminating means 8d consecutively eliminates indoor units starting with the one having the lowest priority in operation, and effects discrimination on the basis of the priorities in operation and eliminates low-priority indoor units until the total capacity of the indoor units whose operation has been requested by the remote controllers 3 falls within the capacity of the outdoor unit.

It should be noted that the priorities in operation are set in advance for the remote controllers 3 as follows.

For instance, the priorities in operation are based on the purpose of use or importance of the room where the indoor unit 2 is installed, the order of magnitude of the capacity of the indoor unit for each remote controller 3, and the like.

Next, when the total capacity of the indoor units has fallen within the capacity of the outdoor unit, on the basis of the result of this discrimination the capacity-control commanding means 8e controls the operating conditions of the indoor units 2 whose operation has been requested by the remote controllers, in response to the result of operation of each remote controller.

It should be noted that, at this time, since the outdoor unit 1 and the indoor units 2 transmit their latest operating conditions (operating temperature, pressure, etc.) to the operation controlling means 8, the operation controlling means 8 causes the result of operation to be displayed on a display unit (not shown).

Next, after the lapse of a predetermined time period in a state in which the indoor units whose operation was allowed are being operated, or when the indoor unit whose operation was allowed has stopped, if the remote controller 3 of another indoor unit is operated and a request for operation is made, the operation controlling means 8 effects determination processing as to whether or not the result of operation

(request for operation of the indoor unit) of the remote controller which has been operated again is to be approved, in accordance with the aforementioned criterion (whether or not the total capacity of the indoor units whose operation has been requested by the remote controllers is within the capacity of the outdoor unit).

It should be noted that if the total capacity of the indoor units whose operation is presently allowed and the indoor unit whose operation has been requested by the remote controller is within the capacity of the outdoor unit, the request for operation which has been made by the remote controller is also approved.

However, if it is determined that the total capacity of the indoor units exceeds the capacity of the outdoor unit, the operation controlling means 8 checks the aforementioned preset priorities in the operation of the indoor units, and if the priority in operation concerning the remote controller which has made the request for operation is higher than the priorities of the indoor units whose operation is presently allowed, the operation controlling means 8 consecutively stops indoor units starting with the one having the lowest priority in operation among the indoor units whose operation is presently allowed. Then, after effecting discrimination such that the total capacity of the indoor units falls within the capacity of the outdoor unit, the operation controlling means

8 allows the operation of the indoor unit for which the request for operation has been made.

As has been described above, the air conditioning system is arranged such that it comprises: the plurality of indoor units which are connected to the outdoor unit and whose total capacity is greater than the capacity of the outdoor unit; the remote controllers which are operated for respectively controlling operating conditions of the plurality of indoor units; and the operation controlling means for controlling the operating conditions of the plurality of indoor units on the basis of the results of operation of the remote controllers. In this air conditioning system, the operation controlling means calculates the total capacity of the indoor units whose operation has been requested by the remote controllers, determines whether or not the result of this calculation is within the capacity of the outdoor unit, and controls on the basis of the result of that determination the operating conditions of the indoor units whose operation has been requested, when the total operating capacity of the indoor units is within the capacity of the outdoor unit, in accordance with the result of operation of each of the remote controllers. Accordingly, it is possible to obtain an economical and easy-to-use air conditioning system which air-conditions each room and excels in energy efficiency by making efficient use of the outdoor unit, while constantly responding to requests for operation of the indoor units without excessively enlarging the

capacity of the outdoor unit wastefully in correspondence with the total capacity of all the indoor units.

In addition, if it is determined that the total capacity of the indoor units exceeds the capacity of the outdoor unit in the result of determination by the determining means, the discriminating means checks the priorities in the operation of the indoor units whose operation has been requested by the remote controllers. Then, indoor units starting with the one having the lowest priority in operation are consecutively stopped, and the operating conditions of the indoor units are controlled after the total capacity of the indoor units whose operation was requested has fallen within the capacity of the outdoor unit, in accordance with the result of operation of each remote controller. Accordingly, it is possible to obtain an economical and easy-to-use air conditioning system which air-conditions each room and excels in energy efficiency by making efficient use of the outdoor unit, while responding to requests for operation of the indoor units without excessively enlarging the capacity of the outdoor unit wastefully in correspondence with the total capacity of all the indoor units.

In addition, if an arrangement is provided such that, as shown in Fig. 7, the operation controlling means 8 outputs for a predetermined time period an operation inhibiting command to the remote controllers 3 other than the remote controllers 3 whose operation has been allowed, and the operation returns

to a start after the lapse of the predetermined time of this stop command or when the operation controlling means 8 has received a stop signal from the remote controller whose operation was allowed, then it is possible to obtain a highly reliable air conditioning system which performs more stable operation since the operation of the remote controllers 3 other than the remote controllers whose operation has been allowed is stopped for the predetermined time period.

(Second Embodiment)

Referring now to Figs. 3, 4, and 7, a description will be given of a second embodiment.

It should be noted that, in this second embodiment, the plurality of indoor units in the first embodiment are divided into blocks in correspondence with the conditions of use in the rooms where the indoor units are installed, the remote controllers 3 are respectively provided for the divided blocks, and operation similar to that of the first embodiment is performed in correspondence with requests for operation by the remote controllers 3, so as to perform the operation by causing the operating capacity of the indoor units to approach the capacity of the outdoor unit.

Accordingly, in the configuration in accordance with this second embodiment, an operation setting means 7 having an allocation setting means 7a for allocating the indoor units 2 to the respective blocks is added to the configuration of the first embodiment.

Further, the operation controlling means 8 is provided with the following: the calculating means 8a for calculating the total capacity of the indoor units whose operation has been requested by the remote controllers 3 in the respective blocks allocated by the allocation setting means 7a of the operation setting means 7; the determining means 8c for determining whether or not the total capacity of each block calculated by the calculating means 8a is within the capacity of the outdoor unit; and the control commanding means 8e for controlling on the basis of the determination by the determining means 8c the operating conditions of the indoor units 2 whose operation has been requested, when the total capacity of the indoor units is within the capacity of the outdoor unit, in response to the result of operation of each remote controller.

It should be noted that if the total capacity of the indoor units exceeds the capacity of the outdoor unit in the result of the aforementioned determination, the discriminating means 8d discriminates priorities in the operation of the indoor units whose operation has been requested by the remote controllers 3, and after the total capacity of the indoor units is made to fall within the capacity of the outdoor unit, the capacity-control commanding means 8e controls on the basis of the result of that discrimination the operating conditions of the indoor units 2 in response to the result of operation of each remote controller.

Next, referring to Fig. 4, a description will be given of the operation in accordance with this second embodiment.

First, the allocation setting means 7a allocates the indoor units 2 to the respective blocks (e.g., blocks A, B, and C) in correspondence with the conditions of utilization (conditions of use) of the rooms.

It should be noted that the respective remote controllers A, B, and C are installed in the respective blocks A, B, and C, and these remote controllers operate the operating conditions of the respective blocks.

Next, if the remote controllers 3 (e.g., A and B) in certain blocks among these remote controllers A, B, and C are operated, the results of operation (requests for operation) of the remote controllers are transmitted to the operation controlling means 8 via the transmission lines 4.

Next, in the operation controlling means 8, as a result of operation of these remote controllers A and B, its calculating means 8a calculates the total capacity of the indoor units whose operation has been requested by the remote controllers A and B, and transmits the results of calculation to the determining means 8c.

Next, on the basis of these results of calculation, the determining means 8c determines whether or not the total capacity of the indoor units whose operation has been requested by the remote controllers A and B is within the capacity of the outdoor unit.

If the total capacity of the indoor units 2 is within the capacity of the outdoor unit 1 in the result of this determination, an operation enabling command is transmitted to the control commanding means 8e, so that the control commanding means 8e controls the operating conditions of the indoor units in the respective blocks, for which operation has been requested, in response to the results of operation of the remote controllers.

On the other hand, if the total capacity of the indoor units 2 exceeds the capacity of the outdoor unit 1 in the result of the aforementioned determination, by checking the priorities in the operation of the blocks for which operation has been requested by the remote controllers 3, the discriminating means 8d consecutively eliminates blocks of the remote controllers 3 starting with the one having the lowest priority in operation, and effects discrimination on the basis of the priorities in operation until the total capacity of the indoor units whose operation has been requested by the remote controllers 3 falls within the capacity of the outdoor unit.

It should be noted that the priorities in operation are set in advance for the remote controllers 3 as follows.

For instance, the priorities in operation are based on the purpose of use or importance of the room where the indoor unit 2 is installed, the order of magnitude of the capacity of the indoor unit for each remote controller 3, the descending order in the number of indoor units, and the like.

Next, when the total capacity of the indoor units has fallen within the capacity of the outdoor unit, on the basis of the result of this discrimination the capacity-control commanding means 8e controls the operating conditions of the blocks for which operation has been requested by the remote controllers, in response to the result of operation of each remote controller.

It should be noted that, at this time, since the outdoor unit 1 and the indoor units 2 in the respective blocks transmit their latest operating conditions (operating temperature, pressure, etc.) to the operation controlling means 8, the operation controlling means 8 causes the result of operation to be displayed on a display unit (not shown).

Next, after the lapse of a predetermined time period in a state in which the blocks for which operation was allowed are being operated, if the remote controller 3 of another indoor unit is operated and a request for operation is made, the operation controlling means 8 effects determination processing as to whether or not the result of operation (request for operation of the indoor unit) of the remote controller which has been operated again is to be approved, in accordance with the aforementioned criterion (whether or not the total capacity of the indoor units whose operation has been requested by the remote controllers is within the capacity of the outdoor unit).

It should be noted that if the total capacity of the blocks of the remote controllers for which operation is

presently allowed and the block of the remote controller which has made the request for operation is within the capacity of the outdoor unit, the request for operation which has been made by the remote controller is also approved.

However, if it is determined that the total capacity of the indoor units exceeds the capacity of the outdoor unit, the operation controlling means 8 checks the aforementioned preset priorities in the operation of the blocks, and if the priority in operation concerning the remote controller which has made the request for operation is higher than the priorities of the indoor units whose operation is presently allowed, the operation controlling means 8 consecutively stops blocks of the remote controllers starting with the one having the lowest priority in operation among the blocks of remote controllers for which operation is presently allowed. Then, after effecting discrimination such that the total capacity of the indoor units falls within the capacity of the outdoor unit, the operation controlling means 8 allows the operation of the block of the indoor unit for which the request for operation has been made.

As has been described above, the air conditioning system is arranged such that it comprises: the plurality of indoor units which are connected to the outdoor unit and whose total capacity is greater than the capacity of the outdoor unit; the allocation setting means for setting the allocation of the plurality of indoor units to blocks in correspondence

with conditions of utilization of rooms where the indoor units are respectively installed; the remote controllers which are operated for respectively controlling operating conditions of the blocks on the basis of the result of allocation by the allocation setting means; and the operation controlling means for controlling the operating conditions of the blocks on the basis of results of operation of the remote controllers. In this air conditioning system, the operation controlling means calculates the total capacity of the indoor units of the blocks for which operation has been requested by the remote controllers, determines whether or not the result of this calculation is within the capacity of the outdoor unit, and controls on the basis of this determination the operating conditions of the blocks for which operation has been requested, when the total capacity of the indoor units is within the capacity of the outdoor unit, in response to the result of operation of each of the remote controllers. Accordingly, it is possible to obtain an economical and easy-to-use air conditioning system which air-conditions each room in correspondence with the condition of utilization and use of each room, and is suitable for the air conditioning of large facilities such as the air conditioning of buildings, in particular, by making more efficient use of the outdoor unit without excessively enlarging the capacity of the outdoor unit wastefully in correspondence with the total capacity of all the indoor units.

In addition, the arrangement provided is such that the allocation setting means sets the allocation of the plurality of indoor units to blocks (remote controllers) in correspondence with the conditions of utilization of rooms where the indoor units are respectively installed, and if the determining means determines that the total capacity of the indoor units of the remote controller blocks which requested the operation exceeds the capacity of the outdoor unit, the discriminating means checks the priorities in the operation of the indoor units whose operation has been requested by the remote controllers. Then, indoor units starting with the one having the lowest priority in operation are consecutively stopped, and the operating conditions of the blocks are controlled after the total capacity of the indoor units of the blocks for which operation was requested has fallen within the capacity of the outdoor unit, in accordance with the result of operation of each remote controller. Accordingly, it is possible to obtain an economical and easy-to-use air conditioning system which air-conditions each room in correspondence with the condition of utilization and use of each room, is suitable for the air conditioning of large facilities such as the air conditioning of buildings, in particular, and excels in energy efficiency by making more efficient use of the outdoor unit without excessively enlarging the capacity of the outdoor unit wastefully in correspondence with the total capacity of all the indoor units.

In addition, if an arrangement is provided such that, as shown in Fig. 7, the operation controlling means 8 outputs for a predetermined time period an operation inhibiting command to the remote controllers 3 belonging to blocks other than the blocks for which operation has been allowed, and stops such remote controllers 3, then it is possible to obtain a highly reliable air conditioning system which performs more stable operation.

(Third Embodiment)

Referring now to Figs. 5, 6, and 7, a description will be given of a third embodiment.

Fig. 5 is a schematic diagram illustrating a system of air conditioners in accordance with the first embodiment.

In Fig. 1, reference numeral 1 denotes the outdoor unit; 2, the plurality of indoor units whose total capacity is greater than the capacity of the outdoor unit; 3, the remote controllers respectively connected to the plurality of indoor units 2 to control the operating conditions of the indoor units 2; 4, the transmission lines provided for connecting the outdoor unit 1, the indoor units 2, the remote controllers 3, and the operation controlling means 8 which will be described later, and for transmitting bidirectional signals; 5, the controller for the outdoor unit for controlling the operation of the outdoor unit 1; 6, the controllers for the respective indoor units for controlling the operation of the indoor units on the basis of signals from the remote controllers 3; 7, the

operation setting means 7 having the allocation setting means 7a for allocating the indoor units 2 to the respective blocks as well as an operating-time-zone setting means 7b for setting an operating time zone of each of the blocks allocated by the allocation setting means 7a.

Further, reference numeral 8 denotes the operation controlling means 8 which is provided with the following: first and second calculating means 8a and 8b for calculating the total capacity of the indoor units of the blocks allocated by the allocation setting means 7a of the operation setting means 7, and for calculating the total capacity of the indoor units of the operation blocks in the operating time zone set by the operating-time-zone setting means 7b; first and second determining means 8c and 8d for determining whether or not the total capacity of each block calculated by the first and second calculating means 8a and 8b is within the capacity of the outdoor unit; and the control commanding means 8e for controlling the operating conditions of the indoor units 2 of the blocks on the basis of the results of determination by the first and second determining means 8c and 8d in response to the result of operation of each remote controller 3.

In addition, with this air conditioning system, the outdoor unit 1 is naturally provided with a compressor, a four-way valve for effecting a changeover between cooling and heating, an outdoor-side heat exchanger, and an accumulator, and each indoor unit 2 is provided with an indoor-side heat

exchanger, a pressure reducing device, and the like, although they are not shown.

It should be noted that the four-way valve of the outdoor unit 1 and the indoor-side heat exchanger, as well as the outdoor-side heat exchanger and the pressure reducing device of each indoor unit 2, are respectively connected by unillustrated refrigerant pipes, and the outdoor unit 1 and the respective indoor units 2 are connected by these connecting pipes, thereby forming a refrigerant cycle.

Next, referring to the flowchart shown in Fig. 6, a description will be given of the operation in accordance with this first embodiment.

It should be noted that S1-1, S1-2, ..., in this drawing show the respective operations and control operation of the operation setting means 7 and the operation controlling means 8.

First, the indoor units 2 provided in the respective rooms of a store building shown in Fig. 13 are allocated to blocks by the allocation setting means 7a in correspondence with the conditions of utilization of the rooms, as shown in Fig. 9, for example (step S1-1).

It should be noted that, at that time, the same indoor unit may belong to different blocks, respectively.

Next, the operation controlling means 8 requests the allocation setting means 7a to transmit the capacity of the

indoor units 2 in each block thus allocated, i.e., the result of allocation (step S1-2).

In response to this request, the allocation setting means 7a transmits to the operation controlling means 8 the result of allocation (capacity) of the indoor units 2 to each block (step S1-3).

Next, on the basis of the result of this transmission, the operation controlling means 8 calculates the total capacity of the indoor units of the respective blocks by means of its calculating means 8a (step S1-4), determines whether or not the result of this calculation is within the capacity of the outdoor unit 1 by means of the determining means 8b (step S1-5), gives an instruction to proceed to Step S1-6 if the capacity of the indoor units is within the capacity of the outdoor unit in the result of this determination, and gives an instruction to proceed to Step S1-7 if the capacity of the indoor units exceeds the capacity of the outdoor unit.

It should be noted that if it is determined as the result of this determination that the total capacity of the indoor units 2 of the allocated blocks exceeds the capacity of the outdoor unit 1, and the operation proceeds to Step S1-7, the contents of the indoor units 2 allocated to the blocks are cleared in that step. Then, in Step S1-8, a display is given on a display unit (not shown) to reset the allocation of the indoor units 2 in the allocated blocks, and the operation returns to Step S1-1 again.

Namely, since this operation is repeated until the total capacity of the indoor units 2 in the blocks falls within the capacity of the outdoor unit 1, the total capacity of the indoor units 2 in the blocks comes to fall within the capacity of the outdoor unit 1.

Meanwhile, if the operation proceeds to Step S1-6, a display is displayed on the display unit, questioning whether or not another indoor unit 2 is to be set for a given block when the total capacity of the allocated indoor units 2 in the blocks is within the capacity of the outdoor unit 1.

If an instruction is to be given to set another indoor unit 2 in response to this display, the operation returns to Step S101 to repeat the foregoing operation.

However, if an instruction is to be given not to set another indoor unit 2 in response to this display, the operation controlling means 8 determines that the allocation of the indoor units 2 to the blocks has been completed, and a display is given on the display unit to set an operating time zone for each block (step S1-9).

Next, operating time zones for the set blocks are set by the operating-time-zone setting means 7b, as shown in Fig. 11, for example (step S1-10).

It should be noted that the operating time zones for the respective blocks shown in this drawing may be allocated in advance as operating time zones for predetermined time periods,

as shown in Fig. 10. Alternatively, hours from 0 to 24 hours may simply be allocated directly to each block.

In addition, the blocks may be set and allocated to the plurality of operating time zones, respectively.

At this time, however, as shown in Fig. 6, Step S1-11 is provided in which the calculating means 8b calculates the total capacity of the indoor units 2 of the plurality of blocks allocated to a given operating time zone, and the determining means 8c determines whether or not the result of this calculation is within the capacity of the outdoor unit 1. If the result of this calculation is within the capacity of the outdoor unit 1 as the result of this determination, an instruction is given to proceed to Step S1-14, and if the result of this calculation exceeds the capacity of the outdoor unit 1, an instruction is given to proceed to Step S1-13.

Next, if the result of the calculation exceeds the capacity of the outdoor unit, and the operation proceeds to Step S1-13, the contents of the blocks allocated to the operating time zone are cleared in that step. Then, in Step S1-14, a display is given on the display unit (not shown) to reset the allocation of the blocks for that operating time zone, and the operation returns to Step S1-9 or S101 again. Therefore, the blocks in that operating time zone or the indoor units 2 of the given blocks are reset.

Namely, since this operation is repeated until the total capacity of the indoor units 2 in the blocks falls within

the capacity of the outdoor unit 1, the total capacity of the indoor units 2 in the blocks allocated to that operating time zone comes to fall within the capacity of the outdoor unit 1, and the operation proceeds to Step S1-14.

Meanwhile, if the operation proceeds to Step S1-4, storage unit (not shown) of the operation controlling means 8 stores the indoor units 2 of the blocks set for the given operating time zone, and the operation-control commanding means 8e controls the operating conditions of the indoor units 2 of the blocks on the basis of the result of this storage in response to the result of operation of each remote controller.

Incidentally, in the above description, after the indoor units 2 are allocated to blocks by the allocation setting means 7a in correspondence with the conditions of utilization of the rooms, the operating time zones of the blocks are set by the operating-time-zone setting means 7b. However, an arrangement may be provided such that, instead of allocating the indoor units 2 to the blocks, the operating time zones are set directly to the remote controllers 3 for operating the respective indoor units 2.

As has been described above, the air conditioning system is arranged such that it comprises: the plurality of indoor units which are connected to the outdoor unit and whose total capacity is greater than the capacity of the outdoor unit; the remote controllers which are operated for respectively controlling operating conditions of the plurality

of indoor units; the operating-time-zone setting means for setting the operating time zone of each of the remote controllers; and the operation controlling means for controlling on the basis the result of setting by the operating-time-zone setting means the operating conditions of the indoor units in response to results of operation of the remote controllers. In this air conditioning system, the operation controlling means calculates the total operating capacity of the indoor units for the operating time zone set by the operating-time-zone setting means, compares for a determination the result of this calculation with the capacity of the outdoor unit, and after confirming that the total operating capacity of the indoor units does not exceed the capacity of the outdoor unit, the operation controlling means controls the operating conditions of the indoor units in accordance with the result of setting by the operating-time-zone setting means in response to the result of operation of each of the remote controllers. Accordingly, it is possible to obtain an economical and easy-to-use air conditioning system which is capable of varying the air-conditioning time zone of each room in correspondence with the condition of utilization of each room, and excels in energy efficiency by making efficient use of the outdoor unit without excessively enlarging the capacity of the outdoor unit wastefully by causing the capacity of the outdoor unit to correspond to the total capacity of all the indoor units.

In addition, the indoor units are allocated to blocks by the allocation setting means in correspondence with the conditions of utilization of the rooms, the operating time zones of the blocks are set by the operating-time-zone setting means, and the operation controlling means is provided for controlling the operating conditions of the respective indoor units on the basis of the result of this setting in response to the result of operation of each remote controller. The operation controlling means calculates the total operating capacity of the indoor units of the blocks for the operating time zone set by the operating-time-zone setting means, compares the result of this calculation with the capacity of the outdoor unit, and after confirming that the total operating capacity of the indoor units does not exceed the capacity of the outdoor unit, the operation controlling means controls the operating conditions of the indoor units in accordance with the result of setting by the operating-time-zone setting means in response to the result of operation of each of the remote controllers. Accordingly, it is possible to obtain an economical and easy-to-use air conditioning system which is capable of varying the air-conditioning time zone of each block in correspondence with the condition of utilization of the rooms in each block, is suitable for the air conditioning of large facilities such as the air conditioning of buildings, in particular, and excels in energy efficiency by making efficient use of the outdoor unit without excessively enlarging the

capacity of the outdoor unit wastefully by causing the capacity of the outdoor unit to correspond to the total capacity of all the indoor units.

Next, referring to Fig. 8, a specific description will be given of the operation of the operation controlling means 8 for controlling the operating conditions of the indoor units 2 in each block.

First, the operation controlling means 8 confirms to which operating time zone the present time belongs (step S2-1), and the blocks in that operating time zone stored in the storage unit are read on the basis of the result of this confirmation (step S2-2).

Next, the results of operation of the remote controllers 3 for controlling the operating conditions of the thus-read blocks are read, and the operation controlling means 8 controls the operating conditions of the indoor units 2 of the respective blocks on the basis of the result thus read (step S2-3).

Incidentally, at this time, if step S2-4 is added in which the operation controlling means 8 outputs an operation inhibiting command to the remote controllers 3 for controlling the operating conditions of the indoor units 2 in blocks other than the blocks which have been read, and the operation of those remote controllers 3 is inhibited for a predetermined time period, then it is possible to obtain an economical and highly reliable air conditioning system which air-conditions

rooms by making efficient use of the capacity of the outdoor unit without waste while maintaining more stable operation since the total operating capacity of the indoor units is reliably maintained in the state of being always held within the capacity of the outdoor unit for a predetermined time period.

(Fourth Embodiment)

Referring now to Figs. 5 and 12, a description will be given of the configuration and operation in accordance with a fourth embodiment.

It should be noted that this fourth embodiment shows another form of the second embodiment.

Further, if the term "block" referred to in this fourth embodiment is replaced by the term "indoor unit," this fourth embodiment shows another form of the first embodiment.

Next, referring to Fig. 12, a description will be given of the operation in accordance with this fourth embodiment including its configuration.

First, the indoor units are classified and set to blocks by the allocation setting means 7a in correspondence with the utilization time zone and the like of the rooms where the indoor units are installed (step S3-1).

Next, confirmation is made as to whether or not the total capacity of the indoor units 2 for each block thus classified exceeds the capacity of the outdoor unit (step S3-2), and after this confirmation, the total capacity of the

indoor units 2 of the blocks is stored. Namely, the respective remote controllers and the total capacity of the indoor units 2 are stored (step S3-3).

Next, all the combinations of the blocks (remote controllers) are arbitrarily made (step S3-4).

Then, confirmation is made as to whether or not the total capacity of the indoor units of the blocks in each combination is less than or equal to the capacity of the outdoor unit (step S3-5).

Next, combinations of blocks in which the total capacity of the indoor units of the combined blocks is less than or equal to the capacity of the outdoor unit in the result of this confirmation are stored (step S3-6).

It should be noted that, at this time, the combinations of blocks are consecutively stored in the ascending order of the total capacity of the indoor units in the combination of blocks.

Next, on the basis of the result of combination of the blocks (remote controllers) thus stored, a determination is made as to whether or not there is a combination of the remote controllers 3 which made requests for operation (i.e., whether or not the total capacity of the indoor units is less than or equal to the capacity of the outdoor unit) (step S3-7).

If there is a combination of blocks for which requests for operation have been made in the result of this determination, the operation is allowed with respect to the

blocks for which requests for operation have been made (step S3-9).

If there is no combination of blocks for which requests for operation have been made in the result of the aforementioned determination (i.e., the total capacity of operation requested by the remote controllers 3 is not less than or equal to the capacity of the outdoor unit), a combination of remote controllers when the block having the smallest capacity is excluded (the total operating capacity becomes maximum) is selected from among the combinations of blocks for which requests for operation have been made (step S3-8).

Next, the operation returns to Step S3-7 to determine whether this selected combination is present among the aforementioned stored combinations of blocks (remote controllers), and if the selected combination of blocks is present in the result of this determination, the operation proceeds to Step S3-9, and the operation is allowed with respect to the selected combination of blocks.

However, if the selected combination of blocks is not present in the result of that determination, the operation proceeds to Step S3-8 in which a combination of blocks when the block having the next smallest capacity next to the selected block is excluded (the total operating capacity becomes maximum) is selected. Then, a determination is made again in Step S3-7 as to whether or not this selected combination of

blocks is present among the aforementioned stored combinations of blocks. If the combination of blocks is present in the result of this determination, the operation is allowed with respect to that combination of blocks, and if not, the operation in Steps S3-8 through S3-7 is repeated.

Namely, until the total capacity of the blocks for which requests for operation have been made becomes less than or equal to the capacity of the outdoor unit, the step is repeated in which the blocks, starting with the one whose total capacity of the indoor units is the smallest, are consecutively excluded from the blocks for which requests for operation have been made, so as to make the total capacity of the indoor units become less than or equal to the capacity of the outdoor unit.

Incidentally, after the total capacity of the indoor units has become less than or equal to the capacity of the outdoor unit, and an operation enabling signal is transmitted in Step S3-9, the operation controlling means 8 outputs the operation stop command (a command whose signal is not transmitted even if operation is made) to the blocks other than those to which the operation enabling signal was transmitted, until a stop signal is received from the block for which the operation was allowed or until the lapse of a predetermined time (e.g., 5 minutes) (step S3-10).

After the lapse of the predetermined time of this stop command, or if the operation controlling means 8 receives a stop signal from the block for the operation was allowed (step

S3-11), the operation returns to Step S3-4 to repeat similar operation.

It should be noted that, in the aforementioned Step S3-8, processing is effected in which the combination yields a maximum capacity as the total capacity of the indoor units, i.e., processing is effected in which a combination of blocks is obtained in which the total capacity of the indoor units become maximum by excluding the block having the smallest capacity from the blocks for which requests for operation have been made. However, processing may be provided in which a combination of blocks in which the total number of indoor units becomes maximum is obtained.

In addition, processing may be provided in which priority is placed on such a combination of blocks that the total capacity of the indoor units is maximum and, at the same time, the total number of indoor units is maximum.

As described above, the arrangement provided is such that all the combinations of blocks (remote controllers) are arbitrarily made, confirmation is made as to whether or not the total capacity of the indoor units of each combination of blocks is less than or equal to the capacity of the outdoor unit, a comparison is made on the basis of the result of this storage as to whether or not there is a combination of remote controllers which made requests for operation, i.e., the total capacity of the indoor units whose operation has been requested by the remote controllers is calculated, a comparison is made

between the result of this calculation and the capacity of the outdoor unit, and the operation of the indoor units in the respective blocks is controlled on the basis of the result of this comparison. Accordingly, it is possible to obtain an economical and easy-to-use air conditioning system which air-conditions each room and excels in energy efficiency by making efficient use of the outdoor unit, while constantly responding to requests for operation from the remote controllers without excessively enlarging the capacity of the outdoor unit wastefully in correspondence with the total capacity of all the indoor units.

Since the air conditioning system in accordance with the present invention is configured as described above, the following advantages are offered.

The air conditioning system is arranged such that it comprises: the plurality of indoor units which are connected to the outdoor unit and whose total capacity is greater than the capacity of the outdoor unit; the remote controllers which are operated for respectively controlling operating conditions of the plurality of indoor units; and the operation controlling means for controlling the operating conditions of the plurality of indoor units on the basis of the results of operation of the remote controllers. In this air conditioning system, the operation controlling means calculates the total capacity of the indoor units whose operation has been requested by the remote controllers, determines whether or not the result of

this calculation is within the capacity of the outdoor unit, and controls on the basis of the result of that determination the operating conditions of the indoor units whose operation has been requested, when the total operating capacity of the indoor units is within the capacity of the outdoor unit, in accordance with the result of operation of each of the remote controllers. Accordingly, it is possible to obtain an economical and easy-to-use air conditioning system which air-conditions each room and excels in energy efficiency by making efficient use of the outdoor unit, while constantly responding to requests for operation of the indoor units without excessively enlarging the capacity of the outdoor unit wastefully in correspondence with the total capacity of all the indoor units.

In addition, if it is determined that the total capacity of the indoor units exceeds the capacity of the outdoor unit in the result of determination by the determining means, the discriminating means checks the priorities in the operation of the indoor units whose operation has been requested by the remote controllers. Then, indoor units starting with the one having the lowest priority in operation are consecutively stopped, and the operating conditions of the indoor units are controlled after the total capacity of the indoor units whose operation was requested has fallen within the capacity of the outdoor unit, in accordance with the result of operation of each remote controller. Accordingly, it is

possible to obtain an economical and easy-to-use air conditioning system which air-conditions each room and excels in energy efficiency by making efficient use of the outdoor unit, while responding to requests for operation of the indoor units without excessively enlarging the capacity of the outdoor unit wastefully in correspondence with the total capacity of all the indoor units.

In addition, the air conditioning system is arranged such that it comprises: the plurality of indoor units which are connected to the outdoor unit and whose total capacity is greater than the capacity of the outdoor unit; the allocation setting means for setting the allocation of the plurality of indoor units to blocks in correspondence with conditions of utilization of rooms where the indoor units are respectively installed; the remote controllers which are operated for respectively controlling operating conditions of the blocks on the basis of the result of allocation by the allocation setting means; and the operation controlling means for controlling the operating conditions of the blocks on the basis of results of operation of the remote controllers. In this air conditioning system, the operation controlling means calculates the total capacity of the indoor units of the blocks for which operation has been requested by the remote controllers, determines whether or not the result of this calculation is within the capacity of the outdoor unit, and controls on the basis of this determination the operating conditions of the blocks for which

operation has been requested, when the total capacity of the indoor units is within the capacity of the outdoor unit, in response to the result of operation of each of the remote controllers. Accordingly, it is possible to obtain an economical and easy-to-use air conditioning system which air-conditions each room in correspondence with the condition of utilization and use of each room, and is suitable for the air conditioning of large facilities such as the air conditioning of buildings, in particular, by making more efficient use of the outdoor unit without excessively enlarging the capacity of the outdoor unit wastefully in correspondence with the total capacity of all the indoor units.

In addition, the arrangement provided is such that the allocation setting means sets the allocation of the plurality of indoor units to blocks (remote controllers) in correspondence with the conditions of utilization of rooms where the indoor units are respectively installed, and if the determining means determines that the total capacity of the indoor units of the remote controller blocks which requested the operation exceeds the capacity of the outdoor unit, the discriminating means checks the priorities in the operation of the indoor units whose operation has been requested by the remote controllers. Then, indoor units starting with the one having the lowest priority in operation are consecutively stopped, and the operating conditions of the blocks are controlled after the total capacity of the indoor units of the

blocks for which operation was requested has fallen within the capacity of the outdoor unit, in accordance with the result of operation of each remote controller. Accordingly, it is possible to obtain an economical and easy-to-use air conditioning system which air-conditions each room in correspondence with the condition of utilization and use of each room, is suitable for the air conditioning of large facilities such as the air conditioning of buildings, in particular, and excels in energy efficiency by making more efficient use of the outdoor unit without excessively enlarging the capacity of the outdoor unit wastefully in correspondence with the total capacity of all the indoor units.

In addition, the air conditioning system is arranged such that it comprises: the plurality of indoor units which are connected to the outdoor unit and whose total capacity is greater than the capacity of the outdoor unit; the remote controllers which are operated for respectively controlling operating conditions of the plurality of indoor units; the operating-time-zone setting means for setting the operating time zone of each of the remote controllers; and the operation controlling means for controlling on the basis the result of setting by the operating-time-zone setting means the operating conditions of the indoor units in response to results of operation of the remote controllers. In this air conditioning system, the operation controlling means calculates the total operating capacity of the indoor units for the operating time

zone set by the operating-time-zone setting means, compares for a determination the result of this calculation with the capacity of the outdoor unit, and after confirming that the total operating capacity of the indoor units does not exceed the capacity of the outdoor unit, the operation controlling means controls the operating conditions of the indoor units in accordance with the result of setting by the operating-time-zone setting means in response to the result of operation of each of the remote controllers. Accordingly, it is possible to obtain an economical and easy-to-use air conditioning system which is capable of varying the air-conditioning time zone of each room in correspondence with the condition of utilization of each room, and excels in energy efficiency by making efficient use of the outdoor unit without excessively enlarging the capacity of the outdoor unit wastefully by causing the capacity of the outdoor unit to correspond to the total capacity of all the indoor units.

In addition, the indoor units are allocated to blocks by the allocation setting means in correspondence with the conditions of utilization of the rooms, the operating time zones of the blocks are set by the operating-time-zone setting means, and the operation controlling means is provided for controlling the operating conditions of the respective indoor units on the basis of the result of this setting in response to the result of operation of each remote controller. The operation controlling means calculates the total operating

capacity of the indoor units of the blocks for the operating time zone set by the operating-time-zone setting means, compares the result of this calculation with the capacity of the outdoor unit, and after confirming that the total operating capacity of the indoor units does not exceed the capacity of the outdoor unit, the operation controlling means controls the operating conditions of the indoor units in accordance with the result of setting by the operating-time-zone setting means in response to the result of operation of each of the remote controllers. Accordingly, it is possible to obtain an economical and easy-to-use air conditioning system which is capable of varying the air-conditioning time zone of each block in correspondence with the condition of utilization of the rooms in each block, is suitable for the air conditioning of large facilities such as the air conditioning of buildings, in particular, and excels in energy efficiency by making efficient use of the outdoor unit without excessively enlarging the capacity of the outdoor unit wastefully by causing the capacity of the outdoor unit to correspond to the total capacity of all the indoor units.

In addition, since the priorities of operation by the remote controllers are based on one of the descending order of magnitude of the total capacity of the indoor units and the descending order in the number of indoor units, it is possible to obtain an economical air conditioning system which excels in

energy efficiency by making more efficient use of the outdoor unit.

In addition, since the control commanding means controls the operating conditions of the indoor units in response to the result of operation of each remote controller on the basis of the result from the determining means or the discriminating means, and the control commanding means transmits an operation inhibiting signal to the remote controllers other than the remote controllers concerned so as to stop the operation of the remote controllers other than the remote controllers concerned for a predetermined time period, it is possible to obtain a highly reliable air conditioning system which performs more stable operation.

In addition, since each of the remote controllers displays the operation inhibiting signal from the control commanding means on the display unit, it is possible to obtain an easy-to-use air conditioning system which allows an inhibited state to be understood at a glance.

CLAIMS

1. An air conditioning system, comprising:
an outdoor unit;

a plurality of indoor units which are connected to said outdoor unit and whose total capacity is greater than the capacity of said outdoor unit;

remote controllers which are operated for respectively controlling operating conditions of said plurality of indoor units; and

operation controlling means for controlling the operating conditions of said plurality of indoor units on the basis of results of operation of said remote controllers,

wherein said operation controlling means includes calculating means for calculating a total capacity of said indoor units whose operation has been requested by said remote controllers, determining means for determining on the basis of a result of calculation by said calculating means whether or not the total capacity of said indoor units whose operation has been requested is within the capacity of said outdoor unit, and control commanding means for controlling the operating conditions of said indoor units whose operation has been requested on the basis of a determination result of said determining means.

2. An air conditioning system as claimed in claim 1, wherein said control commanding means controls on the basis of said determination the operating conditions of said indoor

units whose operation has been requested, when the total capacity of said indoor units is within the capacity of said outdoor unit, in response to the result of operation of each of said remote controllers.

3. An air conditioning system as claimed in claim 1, wherein said operation controlling means further includes discriminating means for discriminating on the basis of a result of said determination priorities in operation of said indoor units whose operation has been requested when the total capacity of said indoor units has exceeded the capacity of said outdoor unit; and

wherein control commanding means controls on the basis of the discrimination by said discriminating means the operating conditions of said indoor units whose operation has been requested, in response to the result of operation of each of said remote controllers.

4. An air conditioning system comprising:

an outdoor unit;

a plurality of indoor units which are connected to said outdoor unit and whose total capacity is greater than the capacity of said outdoor unit;

allocation setting means for setting the allocation of said plurality of indoor units to blocks in correspondence with conditions of utilization of rooms where said indoor units are respectively installed;

remote controllers which are operated for respectively controlling operating conditions of said blocks on the basis of a result of allocation by said allocation setting means; and

operation controlling means for controlling the operating conditions of said blocks on the basis of results of operation of said remote controllers,

wherein said operation controlling means includes calculating means for calculating a total capacity of said indoor units of said blocks for which operation has been requested by said remote controllers, determining means for determining on the basis of a result of calculation by said calculating means whether or not the total capacity of said indoor units is within the capacity of said outdoor unit, and control commanding means for controlling the operating conditions of said blocks for which operation has been requested on the basis of said determination.

5. An air conditioning system as claimed in claim 4, wherein said control commanding means controls on the basis of said determination the operating conditions of said blocks for which operation has been requested, when the total capacity of said indoor units is within the capacity of said outdoor unit, in response to the result of operation of each of said remote controllers.

6. An air conditioning system as claimed in claim 4, wherein
an outdoor unit;

a plurality of indoor units which are connected to said outdoor unit and whose total capacity is greater than the capacity of said outdoor unit;

allocation setting means for setting the allocation of said plurality of indoor units to blocks in correspondence with conditions of utilization of rooms where said indoor units are respectively installed;

remote controllers which are operated for respectively controlling operating conditions of said blocks on the basis of a result of allocation by said allocation setting means; and

operation controlling means for controlling the operating conditions of said blocks on the basis of results of operation of said remote controllers;

wherein said operation controlling means further includes discriminating means for discriminating on the basis of a result of said determination priorities in operation of said blocks for which operation has been requested when the total capacity of said indoor units has exceeded the capacity of said outdoor unit; and wherein said operation controlling means controls on the basis of the discrimination by said discriminating means the operating conditions of said blocks for which operation has been requested, in response to the result of operation of each of said remote controllers.

7. An air conditioning system comprising:

an outdoor unit;

a plurality of indoor units which are connected to said outdoor unit and whose total capacity is greater than the capacity of said outdoor unit;

remote controllers which are operated for respectively controlling operating conditions of said plurality of indoor units;

operating-time-zone setting means for setting an operating time zone of each of said remote controllers; and

operation controlling means for controlling on the basis a result of setting by said operating-time-zone setting means the operating conditions of said indoor units in response to results of operation of said remote controllers,

wherein said operation controlling means includes calculating means for calculating a total capacity of said indoor units for the operating time zone set by said operating-time-zone setting means, determining means for determining on the basis of a result of calculation by said calculating means whether or not the total capacity of said indoor units for the operating time zone is within the capacity of said outdoor unit, and control commanding means for controlling on the basis of said determination the operating conditions of said indoor units when the total capacity of said indoor units is within the capacity of said outdoor unit, in accordance with the result of setting by said operating-time-zone setting means in response to the result of operation of each of said remote controllers.

8. An air conditioning system comprising:

an outdoor unit;

a plurality of indoor units which are connected to said outdoor unit and whose total capacity is greater than the capacity of said outdoor unit;

remote controllers which are operated for respectively controlling operating conditions of said plurality of indoor units;

allocation setting means for setting the allocation of said remote controllers to blocks in correspondence with conditions of utilization of rooms where said indoor units are respectively installed;

operating-time-zone setting means for setting an operating time zone of each of said blocks on the basis of a result of allocation by said allocation setting means; and

operation controlling means for controlling on the basis a result of setting by said operating-time-zone setting means the operating conditions of said blocks in response to results of operation of said remote controllers,

wherein said operation controlling means includes calculating means for calculating a total capacity of said indoor units for each operating time zone of said blocks set by said operating-time-zone setting means, determining means for determining on the basis of a result of calculation by said calculating means whether or not the total capacity of said indoor units for the operating time zone is within the capacity

of said outdoor unit, and control commanding means for controlling on the basis of said determination the operating conditions of said indoor units of said blocks when the total capacity of said indoor units is within the capacity of said outdoor unit, in accordance with the result of setting by said operating-time-zone setting means in response to the result of operation of each of said remote controllers.

9. The air conditioning system according to claim 3, wherein the priorities of operation by said remote controllers are based on one of the descending order of magnitude of the total capacity of said indoor units and the descending order in the number of indoor units.

10. The air conditioning system according to claim 6, wherein the priorities of operation by said remote controllers are based on one of the descending order of magnitude of the total capacity of said indoor units and the descending order in the number of indoor units.

11. The air conditioning system according to claim 1, wherein said control commanding means controls the operating conditions of said indoor units in response to the result of operation of each remote controller on the basis of the result from said determining means or said discriminating means, and said control commanding means transmits an operation inhibiting signal to said remote controllers other than said remote controllers concerned so as to stop the operation of said

remote controllers other than said remote controllers concerned for a predetermined time period.

12. The air conditioning system according to claim 10, wherein each of said remote controllers displays the operation inhibiting signal from said control commanding means on a display unit.

13. An air conditioning system constructed and arranged to operate substantially as hereinbefore described with reference to and as illustrated on Figures 1 to 12 of the accompanying drawings.



Application No: GB 9812176.7
Claims searched: 1-13

Examiner: Michael Prescott
Date of search: 29 September 1998

Patents Act 1977
Search Report under Section 17

Databases searched:

UK Patent Office collections, including GB, EP, WO & US patent specifications, in:
UK Cl (Ed.P): G3N (NGA9, NGBA1, NGBA2A, NGBA3, NGBA, NGBB3, NGE2)
Int Cl (Ed.6): F24F 11/00
Other: Online: WPI, JAPIO

Documents considered to be relevant:

Category	Identity of document and relevant passage	Relevant to claims
X	GB 2246453 A (Kabushiki Kaisha Toshiba) see page 2 line 29 to page 3 line 9	1-3, 9, 11, 12
A	EP 0543622 A2 (Sanyo Electric Co., Ltd) see abstract	-
X	JP 620162834 (Daikin Ind. Ltd) 18.07.87 see JAPIO abstract 871225 M-655 Vol.11 No.397 pp.64	1-3, 9, 11, 12

X	Document indicating lack of novelty or inventive step	A	Document indicating technological background and/or state of the art.
Y	Document indicating lack of inventive step if combined with one or more other documents of same category.	P	Document published on or after the declared priority date but before the filing date of this invention.
&	Member of the same patent family	E	Patent document published on or after, but with priority date earlier than, the filing date of this application.