

J. B. PHINNEY.
CURTAIN POLE.

APPLICATION FILED NOV. 11, 1908.

914,876.

Patented Mar. 9, 1909.

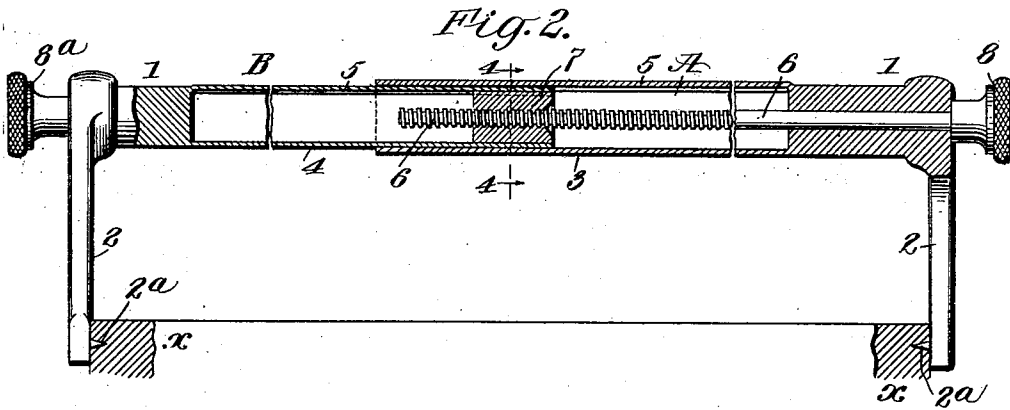
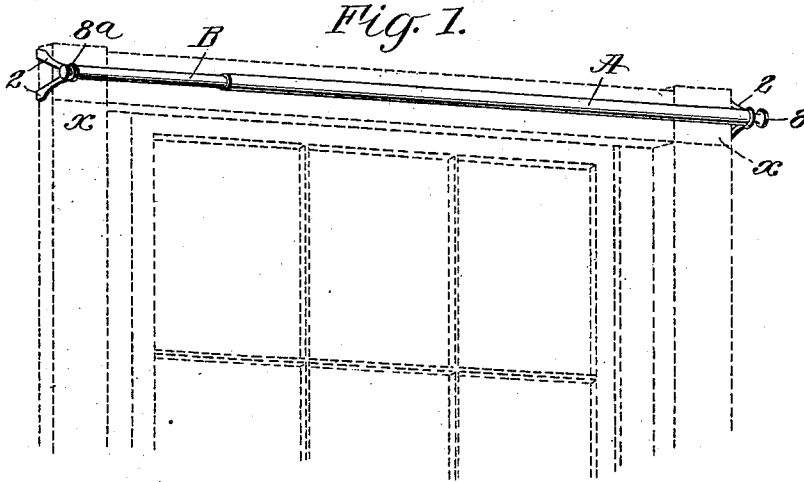

FIG. 4.

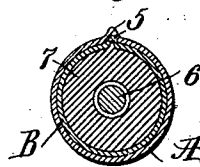

FIG. 3.

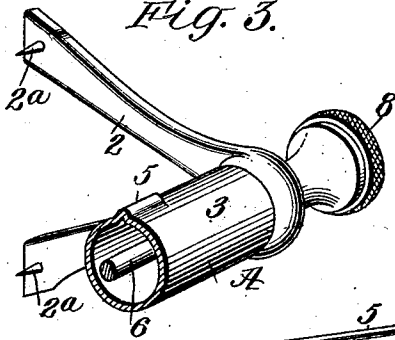
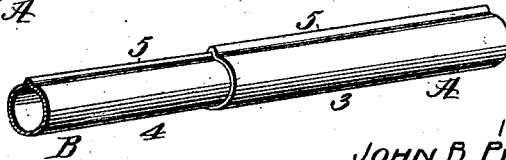

FIG. 5.



WITNESSES
Samuel E. Wade,
Amos W. Hart

INVENTOR
JOHN B. PHINNEY.
BY *Munroe & Co.*

ATTORNEYS

UNITED STATES PATENT OFFICE.

JOHN B. PHINNEY, OF TAMPA, FLORIDA.

CURTAIN-POLE.

No. 914,876.

Specification of Letters Patent.

Patented March 9, 1909.

Application filed November 11, 1908. Serial No. 462,029.

To all whom it may concern:

Be it known that I, JOHN B. PHINNEY, a citizen of the United States, residing at Tampa, in the county of Hillsboro and State of Florida, have invented an Improvement in Curtain-Poles, of which the following is a specification.

My invention is an improved curtain-pole which is made telescopic and provided with a screw clamp whereby it is adapted to be secured to window frames of different widths, without the aid of screws, nails, or brackets, which are usually employed for the purpose.

The details of construction, arrangement, and combination of parts embodying my invention are as hereinafter described, and illustrated in the accompanying drawings, in which—

Figure 1 is a perspective view illustrating the application of my improved curtain-pole to a window frame. Fig. 2 is an enlarged horizontal section of the same. Fig. 3 is a perspective view of the main portion of the curtain-pole. Fig. 4 is a cross section on the line 4—4 of Fig. 2. Fig. 5 is a detail perspective view of the body portion of the curtain-pole.

My improved curtain-pole is composed, as to its body, of two telescopic parts A and B, the former being the socket and the latter the tenon, both parts being constructed as tubes, save at their outer ends 1, which are solid and provided with divergent arms 2, which are arranged at right angles to the axis of the curtain-pole proper and provided at their inner ends with spurs 2^a that project inward and are thus adapted to enter the sides of a window frame *x*, as indicated in Figs. 1 and 2. The tubular portion 3 of the socket part A, and the smaller portion 4 of the tenon part B are formed with a lengthwise rib 5, as shown in Figs. 4 and 5. This rib is formed by bending outward the tubular portions 3 and 4 thus forming crimps, which, when the two parts 3 and 4 are fitted together, prevent the rotation of one on the other. Thus the clamping arms 2—2 at the respective ends of the outer ends of the parts A and B, are held always exactly opposite each other.

It is apparent that the telescopic feature of the curtain-pole enables it to be adjusted, that is to say, contracted and extended, as required to accommodate the invention to window frames of different widths.

The clamping action whereby the curtain-

pole is held securely in place on the window frame *x* is effected by means of a screw 6 whose threaded portion works in a nut 7 secured in the inner end of the tube 4 of the tenon B, as shown in Fig. 2, the outer end of the screw being provided with a head 8, for use in rotating it. The smooth, or unthreaded outer portion of the screw passes through a longitudinal bore in the solid head 1 of the socket part A. It is apparent that by rotating the screw 6, by means of its milled head 8, the two parts A and B may be adjusted one within the other so as to bring the clamping arms 2 nearer each other, and thus cause the spurs or spikes 3 to enter the wood, as shown in Fig. 2, which being done the curtain-pole is secured firmly in position and ready for use. On the other hand, if the screw be rotated in the opposite direction, the two parts A and B will be adjusted so that the clamping arms 2 will be moved farther apart, and thus the curtain-pole will be released from the window frame *x*.

For the sake of symmetry and ornamental appearance the tenon portion B is provided at its outer end with a milled head 8^a which is exactly similar to the head 8 of the screw, and the same is cast integral with the tube 4 and the arms 2.

By the above described construction and combination of parts I provide a telescopic curtain-pole of a minimum number of parts and adapted to be readily applied to a window frame of any dimension and secured thereto without the aid of nails, screws, or other supplemental fastenings. My invention is thus distinguished from window frame attachments adapted to be clamped substantially in the same manner, but which are applicable only to one side of a frame and which require a supplemental attachment in the form of a bracket for supporting the curtain-pole proper. In other words, in my invention the attachment comprises the pole itself as well as the means for securing it to window frames.

What I claim is:

1. The improved curtain-pole, comprising two tubular parts, one adapted to slide within the other, and provided with lateral crimps which coincide and thus prevent rotation of one part on the other, divergent arms provided with spurs and cast integral with the respective telescopic parts, a nut secured in the smaller tubular part, and a screw passing through the outer portion of

the larger or socket part and working in the aforesaid nut, as shown and described.

2. The improved curtain-pole, comprising a body portion which is formed of tubular
5 telescopic parts having solid outer ends or heads and divergent arms arranged at right angles thereto and cast integral therewith, and a nut and screw applied to the respective

telescopic parts and adapted for adjusting the tubular portions axially, as shown and 10 described.

JOHN B. PHINNEY.

Witnesses:

J. W. SHERRILL,
W. B. GRAY.