

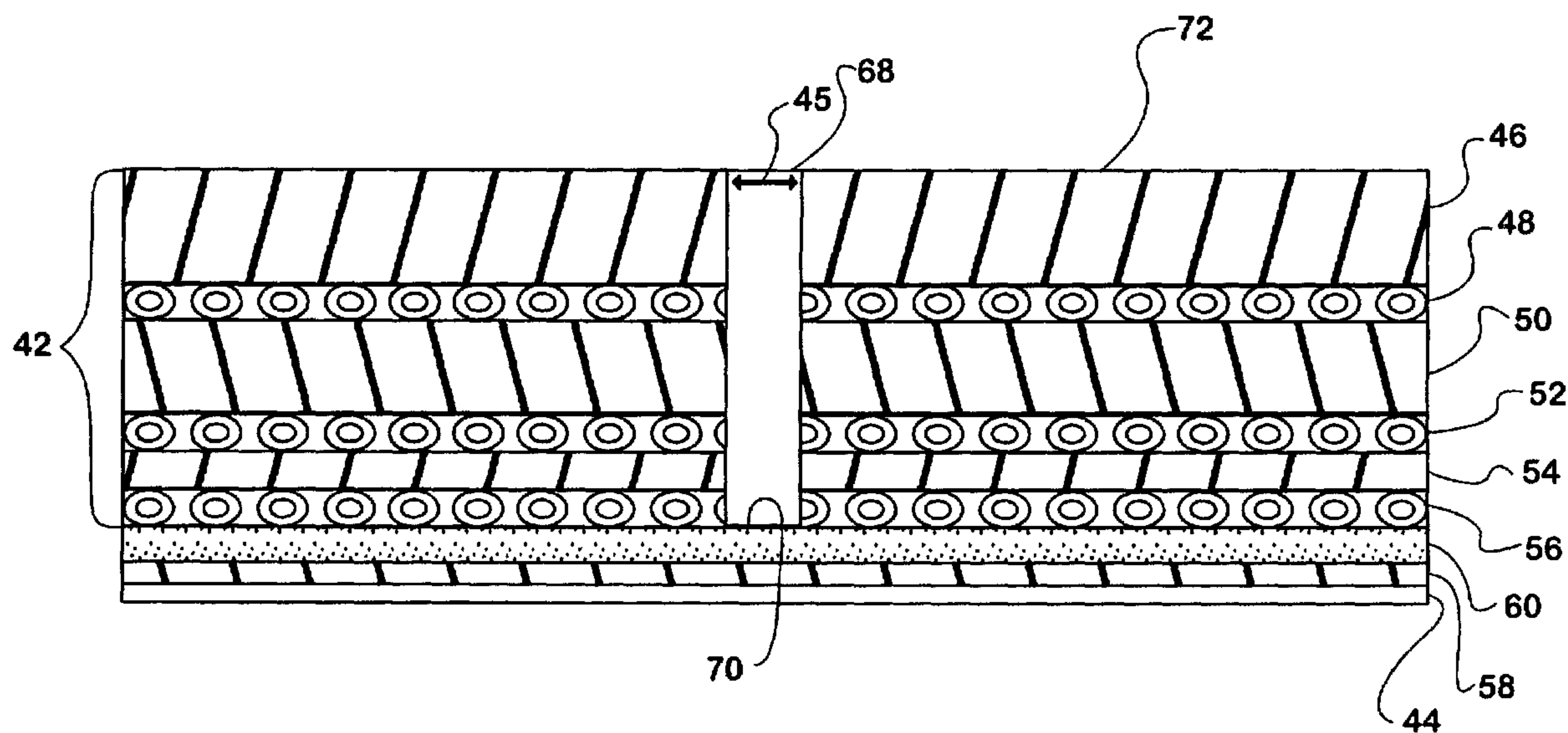

(86) Date de dépôt PCT/PCT Filing Date: 2000/10/13  
 (87) Date publication PCT/PCT Publication Date: 2001/04/26  
 (85) Entrée phase nationale/National Entry: 2002/04/08  
 (86) N° demande PCT/PCT Application No.: US 2000/028379  
 (87) N° publication PCT/PCT Publication No.: 2001/028775  
 (30) Priorité/Priority: 1999/10/15 (09/419,493) US

(51) Cl.Int.<sup>7</sup>/Int.Cl.<sup>7</sup> B41F 13/08  
 (71) Demandeurs/Applicants:  
 ROTATION DYNAMICS CORPORATION, US;  
 MLP U.S.A., INC., US  
 (72) Inventeurs/Inventors:  
 BYERS, JOSEPH L., US;  
 HIX, LESLIE SCOTT, US;  
 BADOWSKI, TIMOTHY F., US;  
 STOCK, MICHAEL F., US  
 (74) Agent: MACRAE & CO.

(54) Titre : BLANCHET A MANCHON COUSU ET SON PROCEDE DE FABRICATION ET D'UTILISATION  
 (54) Title: SEAMED SLEEVED BLANKET AND METHOD FOR MAKING AND USING SAME



(57) Abrégé/Abstract:

The design, production and use of a seamed cylindrical offset printing blanket. Conventional, manufactured blanket material (42) in roll or flat form by methods well known in the art is adhered to a sleeve to economically produce a blanket. The ends (62, 64) of the flat material are joined in close proximity such that the resulting seam or gap (45), from a printing standpoint, is negligibly small. The joint is made with a resilient compound that fills the remaining seam or gap resulting in a useful sleeved blanket. In use, the joint is aligned with non-print areas on the plate cylinder or the opposing plate gap. Since the seam (45) is narrower than the plate gap, no loss of print length results from the seam.

## (12) INTERNATIONAL APPLICATION PUBLISHED UNDER THE PATENT COOPERATION TREATY (PCT)

(19) World Intellectual Property Organization  
International Bureau



(43) International Publication Date  
26 April 2001 (26.04.2001)

PCT

(10) International Publication Number  
**WO 01/28775 A1**

- (51) International Patent Classification<sup>7</sup>: **B41F 13/08**
- (21) International Application Number: PCT/US00/28379
- (22) International Filing Date: 13 October 2000 (13.10.2000)
- (25) Filing Language: English
- (26) Publication Language: English
- (30) Priority Data:  
09/419,493 15 October 1999 (15.10.1999) US
- (71) Applicants (for all designated States except US): **ROTATION DYNAMICS CORPORATION** [US/US]; 8140 Cass Avenue, Darien, IL 60561-5013 (US). **MLP U.S.A., INC.** [US/US]; 600 Barclay Boulevard, Lincolnshire, IL 60069 (US).
- (72) Inventors; and
- (75) Inventors/Applicants (for US only): **BYERS, Joseph, L.** [US/US]; 177 Weaver Road, Inman, SC 29349 (US). **HIX, Leslie, Scott** [US/US]; 50 Meadow Wood Drive, Covington, GA 30014 (US). **BADOWSKI, Timothy, F.** [US/US]; 6110 W. 59th Street, Chicago, IL 60638 (US). **STOCK, Michael, F.** [US/US]; 3134 Chellington Drive, Johnsburg, IL 60050 (US).
- (74) Agents: **PIONTEK, Michael**; Pyle & Piontek, Suite 850, 221 N. LaSalle Street, Chicago, IL 60601 et al. (US).
- (81) Designated States (*national*): AE, AL, AM, AT, AU, AZ, BA, BB, BG, BR, BY, CA, CH, CN, CU, CZ, DE, DK, EE, ES, FI, GB, GD, GE, GH, GM, HR, HU, ID, IL, IN, IS, JP, KE, KG, KP, KR, KZ, LC, LK, LR, LS, LT, LU, LV, MD, MG, MK, MN, MW, MX, NO, NZ, PL, PT, RO, RU, SD, SE, SG, SI, SK, SL, TJ, TM, TR, TT, UA, UG, US, UZ, VN, YU, ZA, ZW.
- (84) Designated States (*regional*): ARIPO patent (GH, GM, KE, LS, MW, MZ, SD, SL, SZ, TZ, UG, ZW), Eurasian patent (AM, AZ, BY, KG, KZ, MD, RU, TJ, TM), European patent (AT, BE, CH, CY, DE, DK, ES, FI, FR, GB, GR, IE, IT, LU, MC, NL, PT, SE), OAPI patent (BF, BJ, CF, CG, CI, CM, GA, GN, GW, ML, MR, NE, SN, TD, TG).
- Published:**  
— With international search report.  
— With amended claims.
- For two-letter codes and other abbreviations, refer to the "Guidance Notes on Codes and Abbreviations" appearing at the beginning of each regular issue of the PCT Gazette.

(54) Title: SEAMED SLEEVED BLANKET AND METHOD FOR MAKING AND USING SAME

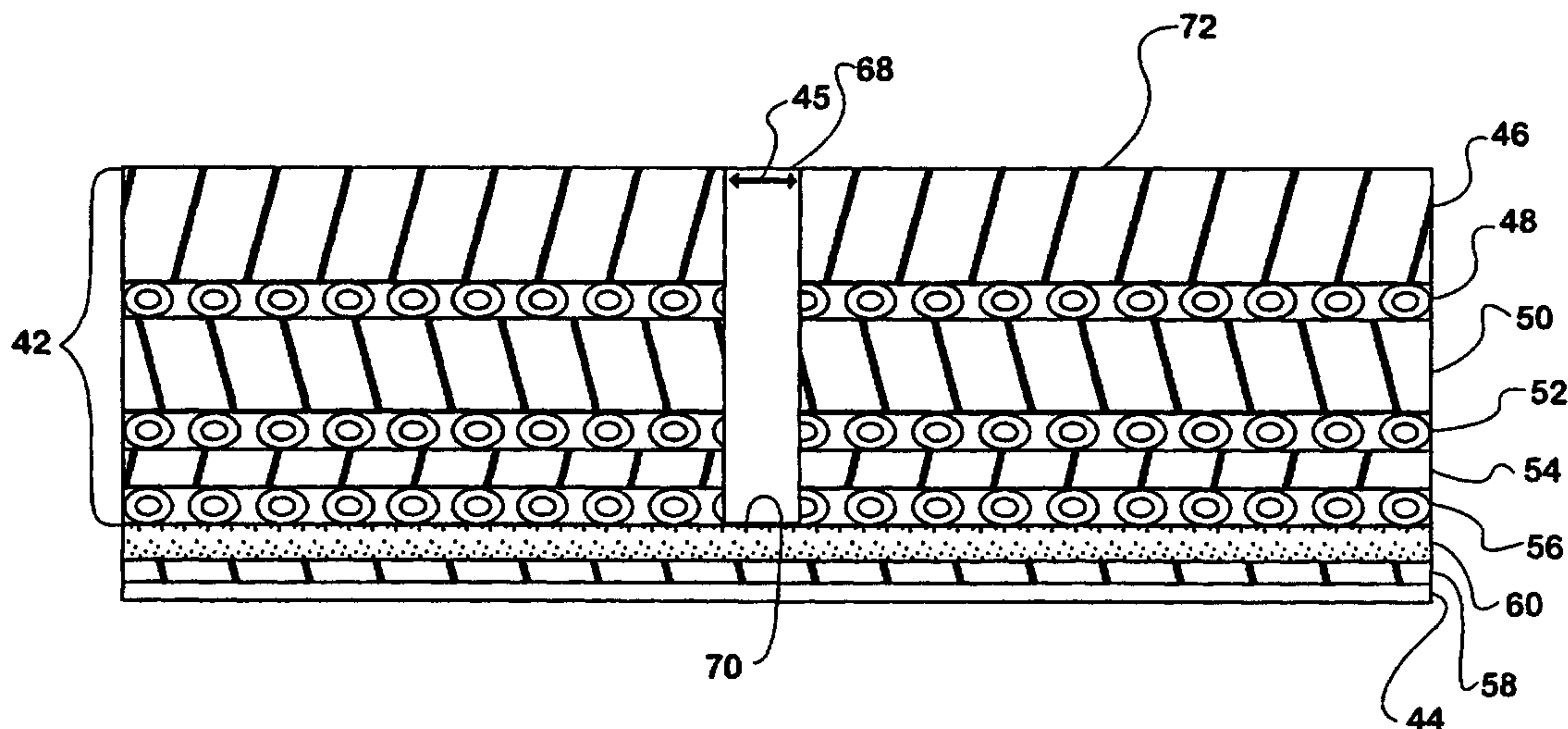

(57) Abstract: The design, production and use of a seamed cylindrical offset printing blanket. Conventional, manufactured blanket material (42) in roll or flat form by methods well known in the art is adhered to a sleeve to economically produce a blanket. The ends (62, 64) of the flat material are joined in close proximity such that the resulting seam or gap (45), from a printing standpoint, is negligibly small. The joint is made with a resilient compound that fills the remaining seam or gap resulting in a useful sleeved blanket. In use, the joint is aligned with non-print areas on the plate cylinder or the opposing plate gap. Since the seam (45) is narrower than the plate gap, no loss of print length results from the seam.

WO 01/28775 A1

**SEAMED SLEEVED BLANKET AND  
METHOD FOR MAKING AND USING SAME**

5           This application is a continuation-in-part of a prior application filed in the United States Patent and Trademark Office as Serial No. 09/419,493 filed on October 15, 1999 on which a claim of priority is based. This invention relates to blankets for printing presses and in more particular to blankets for printing presses using a pre-manufactured or pre-made blanket material which is then formed on a sleeve.

10

**Background of the Invention**

Prior art seamless cylindrical or sleeved offset printing blanket technology is well known in the industry and documented in several patents, for example, those assigned to Heidelberg Harris (U.S. Patent Nos. 5,323,702; 5,429,048; 5,440,981; 15 5,553,541; 5,535,647 and 5,654,100) and to Reeves Brothers Inc. (Patent No. 5,522,315) the contents of all of which patents are hereby incorporated by reference. Two examples of the prior art seamless sleeved blanket 10 are illustrated in the schematic drawings of Figures 1 to 3. Figures 2 and 3 are taken in sections parallel to the circular end of the roll. For ease of illustration, the curvature of the roll has not 20 been shown. The Figure 2 version 10A contains two windings of spiral wound thread 12a and is typical of blankets produced by Reeves and Day (for the Heidelberg presses). The 10A version also has a sleeve 14A, usually of nickel, the spiral wrapped threads 12A, a compressible layer 16A made of typically a rubber containing microspheres, a 25 reinforcing layer 18A carrying another roll of spiral wrapped threads 12A, made of rubber with the treads being cotton, polyester or other materials, and the printing layer 20A having a printing face 22A. Of course, the blanket including its sleeve actually

curve around forming a continuous cylinder. Figure 2 showing the version 10B, contains only one winding of spiral thread 12B and includes a thick rubber base layer 14B. This construction is typical of Sumitomo produced sleeves for use on Mitsubishi presses. This seamless cylindrical sleeve has the inner nickel sleeve 16B, a compressible  
5 layer 18B which can be joined to the base 14B by an adhesive layer 20B. A printing layer 22B is provided and has a printing face 24B. Again, the sleeve 10B actually curves around to form a seamless cylinder as shown in Figure 1.

In the prior art, cylindrical offset sleeved printing blankets, such as discussed above, are produced by spiral winding carrier and reinforcing threads 12A/12B helically  
10 around a continuous sleeve 24A/16B. The sleeve is usually coated with an adhesion promoting primer. A first layer of polymeric coated thread is spiral wound onto the coated sleeve by passing the thread through a dip tank containing the solvated and uncured polymeric material as it is spiraled around the rotating sleeve. Dispersed in the polymeric material of this first layer are hollow microspheres that provide  
15 compressibility to the finished blanket. The amount of the coating is typically controlled as the thread exits the dip tank through a restrictive opening which must be large enough to allow the microspheres to pass through while small enough to prevent excessive coating and the resulting inability to dry and set the polymeric material before sagging can occur. The coating is relatively thick such that the solvents must be  
20 evaporated very slowly prior to curing to prevent trapped gasses from blowing unwanted voids in the finished layer. The long evaporation time tends to slow down the production rate. The polymeric material is then cured. The resulting compressible layer is very rough, uneven and overbuilt, requiring grinding to the required dimensions.

The polymeric material applied by this method tends to maintain its form around the diameter of the thread resulting in unfilled valleys between this layer and the coated sleeve. This unfilled area leads to gauge loss (thickness or diameter loss of a finished blanket sleeve - which can result in loss of printing contact) in the finished product and  
5 is sometimes compensated for by carrying out the additional steps by spreading a filling layer of solvated polymeric material onto the coated sleeve with a doctor blade set up prior to winding of the coated threads. Of course, all of the polymeric material may be applied with a doctor blade set up, as a calendered sheet or other methods known to the art and the threads omitted or spiraled around or under the applied polymeric layer.

10 After grinding the first inner layer to the required dimensions, a second outer layer of polymeric coated thread is wound around the sleeve in a similar fashion to the first layer; however, microspheres are not included. This layer serves as a reinforcing layer and stabilizes the overformed printing surface. Again, the polymeric material may also be applied with a doctor blade set up, as a calendered sheet or other method  
15 known to the art and the threads omitted or spiraled around or under the thus applied polymeric layer.

The overlaid printing surface may be applied as a solvated polymeric compound utilizing a doctor blade set up or as a solid by several methods known to the art such as any known extrusion or calendering process. The completed composite is cross  
20 wrapped or otherwise held in place, then cured with pressure applied to the outer layer by several methods known to the art to mold and adhere all layers together. In the final step the cured composite is again ground to the required dimensions in such a way as to provide a surface profile conducive to ink transfer.

This process results in a cylindrical offset printing blanket that is completely seamless throughout all of its layers but requires every step to be carefully performed on an individual, sleeve by sleeve basis. Efficiencies associated with mass batching of component parts are very limited, if not impossible. It has also been found that cylindrical offset printing blankets produced by this method tend to draw in the width, wrinkle or crease the paper web during use resulting in unacceptable side to side registration through successive printing units. In the prior art, to overcome this deficiency the compressible layer is profiled in a convex manner during the grinding operation to provide a spreading effect on the paper web, further requiring the individual processing of each sleeve during this step in the manufacturing process.

#### **Summary of the Invention**

This invention utilizes a pre-made or pre-manufactured, unitary flat offset printing blanket made by any of the methods known to the art of flat offset printing blanket manufacturing to produce, in mass, a unitized composite blanket covering which can be applied, in a seamed fashion, to a continuous supporting sleeve, such that the seam has a negligible effect on print length and gap bounce. The pre-made blanket material will contain requisite reinforcements which are generally layed out in a rectangular manner, and are not spiral wound. The seam is preferably parallel to the longitudinal axis of the sleeve and not skewed ideally by more than 1/16" of inch for a plate of 1/16" of inch plate gap to avoid registration and print length issues. For other size plate gaps one could use other tolerance but preferably not larger than the plate gap. The opposing ends of the flat blanket should butt together as closely as possible but preferably leave some gap to provide a good fit should cut blanket lengths vary, and the resulting gap should preferably be narrower than the plate gap of the press for

which the sleeve is designed if it is to be aligned in that manner. In this way, the two gaps (one in the blanket - the other on the press plate cylinder) can be aligned during use so that there is no loss of print area or it is limited to the plate gap area. Alternatively, the seam can be made to coincide with any non-utilized area of a plate cylinder, such as, for example, in the trim margins of adjacent print areas.

The invention may include a blanket index, location or locking system or the like, which could use a pin and opening or other mechanism and insures that the blanket and plate gap (or other chosen area) always match perfectly. Preferably, the gap between the opposing ends of the blanket can be filled with a resilient and solvent resistant compound to minimize gap bounce and especially to prevent water and solvents from wicking into the ends of the blanket. If this wicking is not prevented, swelling and delamination would be expected to occur.

In use, installation time is maintained at a minimum by providing a blanket in cylindrical or sleeve form when installed on the press's blanket cylinder. By utilizing flat blanket technology, there is no need for special profiling to spread the paper web. The unitized composite blanket covering may also be purchased as a standard material available from any number of offset printing blanket manufacturers and applied to a continuous supporting sleeve according to the method of this invention.

The sleeve could be made of metallic, for example, nickel or steel, or non-metallic construction, say a solid, laminate or winding of films, such as mylar or thermoplastics. The use of a non-metallic sleeve is possible as there is no need to vulcanize or subject the product to high heat to cure during manufacture.

**Objects of the Present Invention**

It is the object of this invention to provide a seamed offset printing blanket that maintains the benefits of the prior art (maximized print length, minimized gap bounce and reduced installation time) while reducing manufacturing time and expense.

5 It is an object of the present invention to provide a seamed sleeved blanket for a printing press.

It is another object of the present invention to provide a method for making a seamed sleeved blanket for a printing press.

10 It is yet another object of the present invention is to provide a method for using the seamed sleeved blanket of the present invention.

A still further object of the present invention is to provide a seamed sleeved blanket in combination with a printing press.

Yet a further object of the present invention is to provide a combination of seamed sleeved blanket, printing press and indexing, locating or locking system.

15 Another object is to provide a seamed sleeved blanket which can utilize a non-metallic sleeve.

These and other objects of the present invention will become apparent from the following specification and accompanying drawings.

20

**Brief Description of the Drawings**

Figure 1 is a schematic view of a prior art seamless blanket showing where the sections shown in Figures 2 and 3 are taken along the lines 2/3 - 2/3 (the slash meaning "or").

Figure 2 is a cross-sectional view of a segment of a prior art seamless sleeved blanket with the actual curvature being omitted for simplicity.

Figure 3 is a cross-sectional view of a segment of a second prior art seamless sleeved blanket with the curvature being omitted for simplicity.

5 Figure 4 is a schematic view of the seamed blanket of the present invention showing where the section shown in Figure 5 is taken along the lines 5-5.

Figure 5 is a cross-sectional view of a segment of an embodiment of seamed blanket of the present invention, with the curvature being omitted for simplicity.

10 Figure 6 is a schematic view indicating how a sheet of the pre-manufactured blanket material is wrapped around the sleeve to make the seamed sleeved blanket of the present invention.

Figure 7 is a perspective view of the sleeve of the present invention showing how it may be notched to index or lock it into place with respect to a press's blanket cylinder.

15

### **Description of the Preferred Embodiment**

A schematic drawing of the seamed sleeved blanket 40 produced according to this invention can be seen in Figures 4 through 7. As shown in Figure 6, according to  
20 this invention a conventional, flat offset printing blanket material 42 may be manufactured by methods well known to the art or purchased in roll form and cut to specific dimensions so that it can be wrapped (as indicated by the large arrows) as a solid sheet around a continuous supporting sleeve 44 to produce the seamed sleeved blanket 40 of the present invention and shown in Figure 4, the gap or seam being given

numeral 45. Referring to Figure 5, preferably the following construction method can be used. The blanket material 42 could be of any desired commercially available structure and could have a rubber surface 46, say 0.023 inches thick over a first outer fabric layer 48 (reinforcement), say 0.009 inches thick, over a compressible layer 50, say 0.014  
5 inches thick, over a middle fabric layer 52 (reinforcement), say 0.011 inches thick, over an adhesive layer 54, say 0.0002 inches thick, over an inner fabric layer 56 (reinforcement), say 0.015 inches thick. The sleeve could be metallic or non-metallic, and if metallic, preferably of nickel. The expandable nickel sleeve has been the sleeve of choice for sleeve offset blankets. There are alternative materials that can be used  
10 such as fiberglass, kevlar, plastic, and/or a polyethylene (PET) sleeve. Some of these materials and particularly PET have several advantages over the nickel: lower cost, safer for the operator (no sharp edges), more durable than nickel in the manufacturing and pressroom environment. While the reinforcement shown was fabric, other conventional reinforcements could also be used. The sleeve 44 would be treated with a  
15 primer 58, say 0.002 inches thick, and covered with a urethane or other adhesive 60, say 0.002 inches thick, that bonds or adheres the blanket material 42 to the sleeve 44. The across the roll dimension may be cut equal to or less than the length of the sleeve 44 and the around or circumferential dimension may be cut equal to or no more than 1/16" less than the outer surface length or circumference of the sleeve for use on a  
20 press with a plate gap of 1/16 of an inch. Of course, for other size plate gaps, this dimension could vary. The ends 62 and 64 (of Fig. 4) of the flat blanket material 42 may also be cut or skived at an angle so that the ends meet in the seam 45 (indicated by the heavy double arrow in Figure 5) generally flush from top 68 (outer surface) to bottom 70 (inner surface) (see Fig. 5) when wrapped around the sleeve 44. The roll

goods from which the cuts are made may be of any length and width common in the industry but should be maximized to provide the greatest number of cuts possible without excessive cutting waste. Manufacturing or purchasing in this form takes advantage of the efficiencies associated with mass production. It is well known that the wider and longer a roll of printing blanket material is produced, the less the cost per unit area.

The requirements of the flat offset printing blanket material 42 are the same as for any offset printing blanket and may vary according to the specific end use. A typical blanket physicals are: compressible layer 0.008 to 0.014 thick, stretch less than 1.25%, ply adhesion > 2 lbs./linear inch, tensile stretch > 300 pounds/linear inch, Shore A Durometer 70-85. Additionally, the printing face 72 usually will be overbuilt for grinding of the finished product to the required dimensions. The preferred printing blanket construction according to this invention is one containing one or more, but preferably, three plies 48, 52 and 56 of reinforcing fabric bonded together with an adhesive or solvent polymeric resistant cement, preferably a nitrile cement is used. Alternatively, nonwovens, films or other supporting substrate, could be used instead of fabric. As the blanket material was pre-manufactured, the reinforcement generally will not be spiral wound but will run parallel and perpendicular at right angles to the center axis of the blanket cylinder axis and/or the axis of the blanket sleeve when installed on the blanket cylinder. It is believed that the absence of non-spiral windings in the present invention is beneficial to printing, keeping registration and avoiding web draw in. The blanket material should preferably contain a compressible or foam layer 50 between the two upper fabric plies 48 and 52 that is uniform in thickness across the width. This carcass construction should be in a range of 0.025 to 0.070, and preferably,

approximately 0.055 inches in thickness. Of course other thickness could be used. A solvent resistant polymeric printing face 46 preferably made of nitrile or nitrile blends with other polymers is applied over the top ply of fabric and should be in a range of 0.010 to 0.070 and preferably no less than 0.044 inches thick so that the total gauge of the finished flat blanket is in a range of 0.030 to 0.110 and preferably approximately 0.096 inches thick.

After the individual pieces of blanket material 42 are cut to the appropriate size to fit around the sleeve, they are dried in an oven, for about 30 minutes at, for example, 150°F to remove moisture or otherwise treated to remove moisture. Note, the blankets' sleeve is not subject to this drying, making the use of many non-metallic sleeve materials possible. The dried or moisture free blanket 42 is coated with a thin layer of self-curing polymeric material, preferably urethane 54 such as Por-A-Mold S-2868 manufactured by Synair. These self-curing urethanes are hindered by water so that moisture left in the blanket material 42 will prevent adequate cure and adhesion.

The coated blanket is then wrapped around the sleeve 44. The sleeve 44 has a thickness ranging from 0.002 to 0.010, and preferably 0.005 inches thick. The continuous sleeve may be made of suitable expandable or stretchable metal, and preferably nickel. The sleeve and completed blanket should be expandable or stretchable as that is the usual manner in which they are installed on a blanket cylinder.

That is, the sleeve is expanded or stretched with air pressure to permit it to be so installed.

Other bonding materials may be used but often require heat activation. Application of heat to the already cured flat blanket can degrade its physical properties.

Nickel sleeves 22 are preferred but any sleeve, made of a rigid or semi-rigid material and having a Youngs Moduus and thickness that allows it to be expanded sufficiently to slip over the printing cylinder during installation and removal while retracting to fit the outer diameter of the cylinder tightly during use, may be used. As  
5 noted, it is possible to use non-metallic materials for the sleeve in the present invention as the sleeve never need be exposed to high temperatures. The sleeve dimensions must be chosen so that the interference between the inside diameter of the sleeve and the outside diameter of the printing cylinder on which it will be mounted prevents slippage around the cylinder during use. For example, 0.005 inch thick nickel sleeve should  
10 have an inside diameter of 0.002 to 0.020 less than the outside diameter of the blanket cylinder on which it will be mounted.

The sleeve 22 is first treated and primed (see Figure 5, numeral 58) in a manner common to the art and further coated with the self-curing urethane. The preferred primer is a single coat primer such as Pliogrip 6025, marketed by Ashland Chemical.  
15 Two coat primer systems may also be used.

The urethane or other coating is preferably applied to the back of the flat blanket by a doctor blade to completely fill the interstices of the fabric backing increasing the overall blanket thickness minimally or not at all. The urethane coating is applied to the sleeve by brushing but may also be applied by dipping, spreading with a  
20 doctor blade, spraying or other methods known to the art. The adhesive thickness may vary depending on the adhesive system used and should be consistent with the adhesive manufacturer's directions.

Hydrogenated nitrile rubber compounds have been successfully used in place of the urethane as solvated and spread adhesives or as calendered adhesive sheets. This

method requires curing of the completed composite under pressure and at elevated temperatures while the urethane can be cured at room temperature. Of course, there are many other non-rigid adhesives that can be used to bond the blanket to the sleeve, such as acrylics or rubber based adhesives. They are only limited by the need for  
5 solvent and water resistance.

The ends 62 and 64 of the blanket are butted to each other such that the joint or seam 45 runs preferably parallel to the longitudinal axis of the sleeve. This butt joint should not be skewed by more than 1/16" to prevent misregistration (see discussion above), short print, walking, or unacceptable movement of the printed web.

10 While being manufactured, to hold the flat blanket material in place on the sleeve, it may be secured in place with clamps and spiral wrapped with mylar or other tape under controlled tension (2 -10 lbs./in.), removing the clamps as the tape spiral traverses the length of the sleeve. The mylar or other tape is butt or spiral would in such a way that successive wraps overlap one another sufficiently (5 to 95% -  
15 preferably, 40 to 60%) to apply pressure to the entire surface of the blanket. Alternatively, the blanket may be secured with adhesive tape prior to wrapping with mylar and/or the entire blanket may be enclosed in a mold that simultaneously holds the blanket in position and applies the appropriate pressure. The self-curing urethane cures and bonds the flat blanket to the primed nickel sleeve within 24 hours at room  
20 temperature. This cure rate can be accelerated with exposure to elevated temperatures, so long as those temperatures do not degrade the product. 150°F is a good curing temperature that would reduce the cure time to about 8 hours. The mylar tape or mold is then removed.

This invention includes the concept of using a manufacturing fixture or mold to improve the manufacturing quality of the blankets. The idea is to use a device such as a manufacturing fixture or a mold that would allow the seam to be located, aligned precisely, and securely held during the curing process. The fixture would also apply  
5 even pressure on the surface of the blanket after it has been wrapped around the tubular sleeve. This replaces the manual method of "wrapping" the blanket prior to curing the bonding agent. The result is that the blanket quality can be reproduced consistently. The skill level of the manufacturing person is not as critical. It will also lend to automating the entire manufacturing process in order to reduce the cost and increase  
10 the quality. For example, the mold or fixture would be generally "C" shaped in cross-section and closed by over center clamps that pull the mold or fixture closed. That is, the "C" closes upon itself to form an "O", with the blanket material sleeve in the center of the "O". After the material cures, the blanket sleeve is released from the mold and finished, as by grinding on its outer surface.

15 The remaining gap 45, if any, between the opposing ends of the blanket, can be filled with the urethane or nitrile material and allowed to cure adhering the two ends together and providing a suitable surface. The gap 45 should be filled with a resilient and solvent resistant compound to minimize gap bounce and to prevent water and solvents from wicking into the ends of the blanket. Of course, if the ends 62 and 64 are  
20 really a close fit or touching, then only sealing may be needed to prevent wicking, any such small or negligible gap not needing further filling.

It is also preferred that when used the gap filler material be of a different color from the blanket face so that the seam location is easily identified for proper alignment during installation. The same urethane is also utilized to seal the blanket materials 42

edges and prevent wicking into the sides of the blanket. The different color seam and a mark on the blanket cylinder could form part of an indexing system for properly locating the seam. Of course, another indicator than the seam could also be placed on the blanket cylinder and used with an appropriate mark on the blanket cylinder for  
5 indexing purposes.

Grinding to the appropriate diameter and surface roughness finishes the composite seamed cylindrical blanket. The diameter is specific to the press on which the sleeve will be used should be such that, in combination with the blanket's compressibility, excessive pressure does not cause slippage around the print cylinder.  
10 The appropriate surface roughness is achieved by selection of the face compound and grinding media. The "roughness average" (Ra) should be in the range of 0.2 to 2.0 microinches.

Prior art cylindrical blankets are typically built with a minimally thick composite covering the nickel sleeve. This results in excessive heat transfer to the cylinders on  
15 which they are mounted. During grinding, the heat transfer to the grinding mandrel can cause distortions requiring two stage or wet grinding. The blanket is first rough ground, allowed to cool and then finished. The thickness of the composite covering of this invention is such that heat transfer is negligible. Grinding may be accomplished in a single step and without the mess or capital expense associated with wet grinding.

20 According to this invention, multiple flat blanket pieces may be seamed together on a single sleeve for use on presses having multiple printing plates and thus multiple plate gaps. Such a blanket would have seams corresponding to the plate gaps and could be made to register with them. Also, according to the present invention any seam

or seams on the sleeved blanket could be set up to fall in any corresponding area on the plate cylinder that did not interfere with useful printing.

The use of a mold to hold the flat blanket in position and apply pressure while the urethane cures allows for the possibility of using pre-ground or cast face blanket coverings. The impressions left by cure tapes/wraps require grinding of the finished sleeve, while the use of a mold leaves no such impressions. In this method, the gauge of the flat blanket material 42 covering and the outside diameter of the nickel sleeve control the outside diameter of the finished sleeve. Surface profiles are imparted in mass to the rolls of flat blanket material prior to cutting by methods well known to the art and reduce another unit by unit processing step.

The manufacturing costs associated with the prior art are high and the process is very slow. Output from the method of the present invention is three to four times higher than that of the prior art. And much of the auxiliary equipment such as blanket curing ovens, winding lathes, etc., are not needed. Production or purchasing of the blanket material covering in roll or flat form and large quantity significantly reduces the cost and individual seamed sleeves of the present invention can be completed at a rate of at least one every hour on the same machinery without the auxiliary equipment.

Unit to unit variations are common in the prior art. According to this invention, all seamed sleeves of the present invention produced from the same master roll of flat blanket material will be very consistent in properties.

In the prior art, there are no reinforcing or stabilizing threads in the horizontal direction. The threads applied in the circumferencial direction are not parallel to the end plane of the sleeve. It is possible that this thread orientation is responsible for the tendency to draw in the paper web during use and the consequent side to side

misregistration from printing unit to printing unit. The seamed cylindrical blanket of this invention provides threads both perpendicular and parallel to the axis of the sleeve and no such registration shift issues occur. The need for profiling the compressible layer is not necessary.

5 Prior art seamless, sleeved or cylindrical blankets have historically slipped fractionally around the printing cylinder during use which causes print distortion. The proper combination of the blanket compressibility and finished outside diameter of the secured sleeved blanket of the present invention has been found to eliminate this slippage.

10 In addition, sleeves may be used in the invention that are made of plastic, rubber, fiberglass, kevlar or other suitable materials having appropriate elasticity characteristics. Since our invention requires no final vulcanization process, sleeve materials with softening point less than 300° F can now be considered for use. This was not possible with cylindrical blanket made by the prior art.

15 This invention also provides for a sleeve to blanket cylinder lock up system. The lock up system guarantees that once the blanket is installed it will not slip circumferentially or axially on the blanket cylinder. This movement has been a problem with prior art. For example, a notch or opening 80 could be provided in the sleeve which cooperates with a raised portion or pin 82 (indicated in dashed lines in Figure 7)

20 on the plate cylinder. Other suitable two part mechanisms or male and female portions that fit together could also be used, one in the sleeve with the other in the plate cylinder. Should a full locking system not be desired or needed, the sleeve and plate cylinder could be provided with appropriate indexing marks to locate the seam in the

desired area, be it in the plate gap or other non- utilized non-printing area of the plate on the plate cylinder of the press.

While the preferred form of seamed, sleeved blanket and method of making and using the same of the present invention have been disclosed and described, it should be understood that other equivalent steps and elements of those called for in the below  
5 claims fall within the scope of the appended claims.

PCT/US 00/28379  
IPEA/US 11 DEC 2001

18

**What Is Claimed Is:**

1. A method for making a gapped sleeved blanket for a printing press utilizing pre-made blanket material and a cylindrical sleeve having an outer  
5 circumference and an outer circumferential surface, comprising the steps of:

cutting the pre-made blanket material to a length about that of the outer  
circumference of the cylindrical sleeve,

placing the pre-made blanket material around the outer circumference of the  
cylindrical sleeve,

10 bringing the opposite ends of the pre-made blanket material towards each other  
to have them lie adjacent each other to form a gap on the outer circumference of the  
cylindrical sleeve, and

adhering the pre-made blanket material to the outer circumferential surface of  
the cylindrical sleeve.

15

2. A method of claim 1, comprising the further step of priming the outer  
circumferential surface of the cylindrical sleeve prior to the step of adhering the pre-  
made blanket material to the cylindrical sleeve.

20

3. A method of claim 2, comprising the step of applying a urethane  
adhesive to the primed cylindrical sleeve before carrying out the step of bringing the  
opposite ends of the pre-made blanket material toward each other to have them lie  
adjacent each other to form the gap.

18A

4. The method of claim 1, wherein said cutting step comprises cutting the blanket material at one or more angles so that the cut edges of blanket material lay close together when wrapped around said sleeve.
5. The method of claim 1, comprising the further step of filling the gap between the opposite ends of the pre-made blanket material with filler to form a seam.

6. The method of claim 5, comprising the step of finishing the pre-made blanket material and the filler to have about the same outer radial dimension.

7. The method of claim 1, comprising the step of finishing the pre-made  
5 blanket material to have about the same outer radial dimension.

8. The method of claim 1, comprising providing a pre-made blanket material of thickness of 0.030 to 0.110 inches thick and providing a metallic cylindrical sleeve of a thickness of 0.002 to 0.010 inches thick.

10

9. The method of claim 1, comprising the step of providing a non-metallic cylindrical sleeve.

10. The method of claim 9, comprising providing the non-metallic cylindrical  
15 sleeve and pre-made blanket material to have a combined thickness of generally about the distance between that of the blanket cylinder and the printing surface of a plate of a plate cylinder of the printing press on which the seamed sleeved blanket is adapted to be used.

20 11. The method of claim 9, wherein the non-metallic cylindrical sleeve is formed by two or more layers of non-metallic material.

19A

12. The method of claim 10, wherein the non-metallic cylindrical sleeve is formed by wrapping the non-metallic material.

AMENDED SHEET

13. The method of claim 1, comprising providing a pre-made blanket material having at least one reinforced layer therein.

14. The method of claim 13, comprising the step of providing a pre-made blanket material having a reinforced layer with three fabric layers therein.

15. The method of claim 3 comprising the steps of:

providing a pre-made blanket material of thickness of 0.030 to 0.110 inches thick and providing a cylindrical sleeve of a thickness of 0.002 to 0.010 inches thick,

providing a pre-made blanket material having at least one reinforced layer thereon,

filling the gap with material to form a seam, and

finishing the blanket material and seam to the desired dimension.

16. A seamed sleeved blanket for use on a printing press having a plate cylinder with at least one plate gap, comprising an expandable, continuous, cylindrical sleeve, a sheet of pre-made blanket material wrapped around the continuous, cylindrical sleeve wherein the edges of the pre-made blanket material form a gap about the width of the plate cylinder gap or smaller,

said pre-made blanket material having a supportive substrate, with a compressible layer, adhesive for attaching the pre-made blanket material to the cylindrical sleeve and material filling the gap to form a seam.

**PCT/US 00/28379**  
**IPEA/US 11 DEC 2001**

20A

17. A seamed sleeved blanket for use on a printing press having a plate cylinder with a printing surface, comprising an elastically expandable cylindrical sleeve, a sheet of pre-made blanket material wrapped around said cylindrical sleeve to form a gap, said pre-made blanket material having a supportive substrate with a compressible  
5 layer, adhesive for attaching the pre-made blanket material to said cylindrical sleeve, said gap being filled with material to form a seam, said seam and said cylindrical sleeve being adapted to be located such that said seam does not contact said printing surface of said plate.

AMENDED SHEET

18. A seamed sleeved blanket as in claim 16, wherein said pre-made blanket material has axial exposed edges, said exposed axial edges of said blanket material being sealed.

5 19. A seamed sleeved blanket as in claim 16, wherein said filler and blanket material have outer surface about the same outer radial dimension.

20. A seamed sleeved blanket as in claim 16, wherein said pre-made blanket material is adhered to said sleeve.

10

21. A seamed sleeved blanket as in claim 16, wherein said pre-made blanket material has at least one reinforcement layer and at least one compression layer therein.

15 22. A seamed sleeved blanket as in claim 16, wherein said blanket material has at least two or more reinforcement layers therein.

23. A seamed sleeved blanket as in claim 16, wherein said blanket material has non-spiral wound reinforcement material therein.

24. A seamed sleeved blanket as in claim 16, wherein said cylindrical sleeve is made of a metal that can be elastically expanded to place the seamed sleeved blanket onto a blanket cylinder of a press.

5 25. A seamed sleeved blanket as in claim 24, wherein said cylindrical sleeve is made at least partially of nickel.

26. A seamed sleeved blanket as in claim 16, wherein said cylindrical sleeve is coated with a primer to increase the adherence of the blanket material to the  
10 cylindrical sleeve.

27. A seamed sleeved blanket as in claim 16, wherein said cylindrical sleeve is made of a non-metallic material that can be elastically expanded to place the seamed cylindrical sleeved blanket onto a blanket cylinder of a press.

15

28. A seamed sleeved blanket as in claim 27, wherein said cylindrical sleeve is made of a non-metallic material with one or more laminations and wrappings.

29. A seamed sleeved blanket as in claim 16, wherein a urethane adhesive  
20 adheres said pre-made blanket material to said cylindrical sleeve.

**PCT/US 00/28379**  
**IPEA/US 11 DEC 2001**

22A

30. A seamed sleeved blanket as in claim 16, wherein said pre-made blanket material is adhered to said cylindrical sleeve, and said gap is filled with the same adhesive that attaches said pre-made blanket to said sleeve.

**AMENDED SHEET**

31. A seamed sleeved blanket as in claim 30, wherein said same adhesive is urethane adhesive.

32. A seamed sleeved blanket as in claim 16, wherein said pre-made blanket material is attached to said sleeve, said pre-made blanket material has at least  
5 one reinforcement layer therein, said cylindrical sleeve being made of a metal that can be elastically expanded to place the seamed sleeved blanket onto a blanket cylinder of the printing press, said cylindrical sleeve being made at least partially of a nickel, said cylindrical sleeve being coated with a primer to increase the adherence of the pre-made  
10 blanket material to the sleeve, and a urethane adhesive that adheres said pre-made blanket material to said cylindrical sleeve and is also used to fill said gap.

33. A seamed sleeved cylindrical blanket as in claim 30, wherein said pre-made blanket material is from 0.030 to 0.110 inches thick and said cylindrical sleeve is from 0.002 to 0.010 inches thick.

15

34. The method of claim 1 for using a seamed sleeved blanket, wherein said printing press having a blanket cylinder and a plate cylinder with a plate gap, and a printing plate having leading and trailing ends wrapped around said plate cylinder with said leading and trailing ends tucked into said plate gap, with said printing plate having  
20 a useable print area, comprising the step of indexing the seam of the seamed sleeved blanket to not coincide with the useable print area of the printing plate, and installing the seamed sleeved blanket on the blanket cylinder so that the seam does not align with useable print area of said printing plate.

**PCT/US 00/28379**  
**IPEA/US 11 DEC 2001**

23A

35. A method as in claim 34, wherein said seam is indexed to align with said plate cylinder gap.

AMENDED SHEET

36. A method as in claim 34, comprising the further step of locking the seamed sleeved blanket to the blanket cylinder.

37. The seamed cylindrical sleeved blanket of claim 16, wherein said  
5 printing press having a plate cylinder with a plate gap, and a printing plate having leading and trailing ends wrapped around said plate cylinder with said leading and trailing ends tucked into said plate gap, with said printing plate having a useable printing area therein, a blanket cylinder, and locking means on said printing press to lock the position of said seamed sleeve blanket to said blanket cylinder so that said  
10 seam of said seamed sleeved blanket does not align with the useable print area on said printing plate.

38. The combination of claim 37, wherein said seam aligns with said gap of said plate cylinder.

15

39. The combination of claim 37, wherein said locking means comprises a mechanism on said seamed sleeved blanket and a cooperating mechanism on said blanket cylinder.

20

40. The combination of claim 39, wherein one of said mechanisms is a male component and the other of said mechanisms is a female component, said male and female components locking and fitting together.

**PCT/US 00/28379**  
**IPEA/US 11 DEC 2001**

24A

41. The combination of claim 40, wherein said male component is on said blanket cylinder and said female component is on said seamed cylindrical sleeve.

**AMENDED SHEET**

**PCT/US 00/28379**  
**IPEA/US 11 DEC 2001**

25

42. The combination of claim 39, wherein locking means is a raised portion or pin on said blanket cylinder and a notch or opening formed in said seamed cylindrical sleeve, said raised portion or pin being engagable in said opening or notch to locate the cylindrical sleeve.

5 43. The method of claim 1 comprising the step of enclosing the blanket material in a mold and using the mold to precisely form the sleeved blanket.

44. The method of claim 43, wherein the sleeve is formed of polyethylene.

10 45. A seamed blanket as in claim 17, wherein said pre-cut blanket material is attached to said seamed cylindrical sleeve in a mold.

46. A seamed blanket as in claim 17, wherein said seamed cylindrical sleeve is made of polyethylene.

15

47. A seamed blanket as in claim 46, wherein said pre-cut blanket material is attached to said cylindrical sleeve in a mold.

**AMENDED SHEET**

**FIG. 1**  
**PRIOR ART**

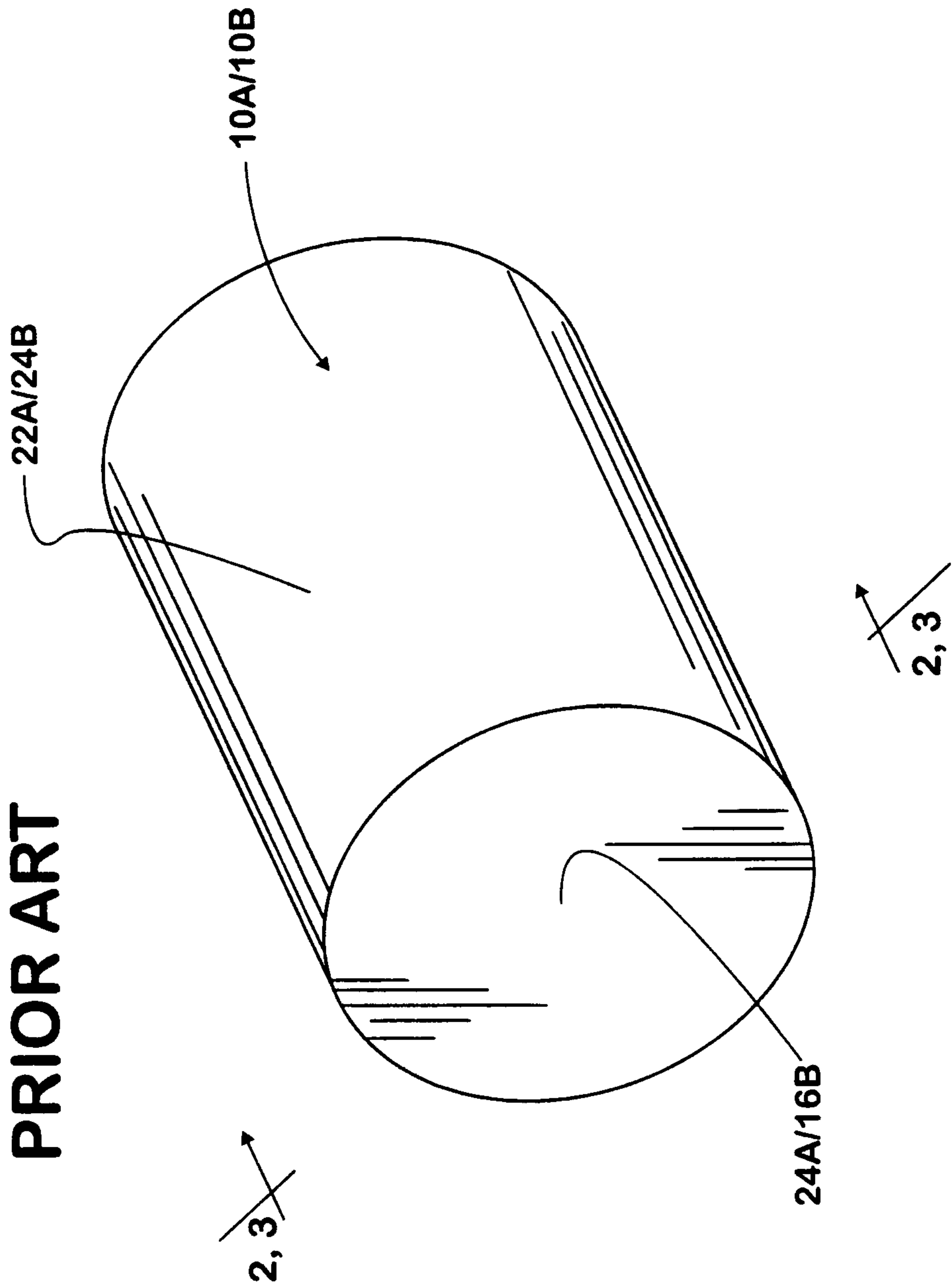

**FIG. 2**  
**PRIOR ART**

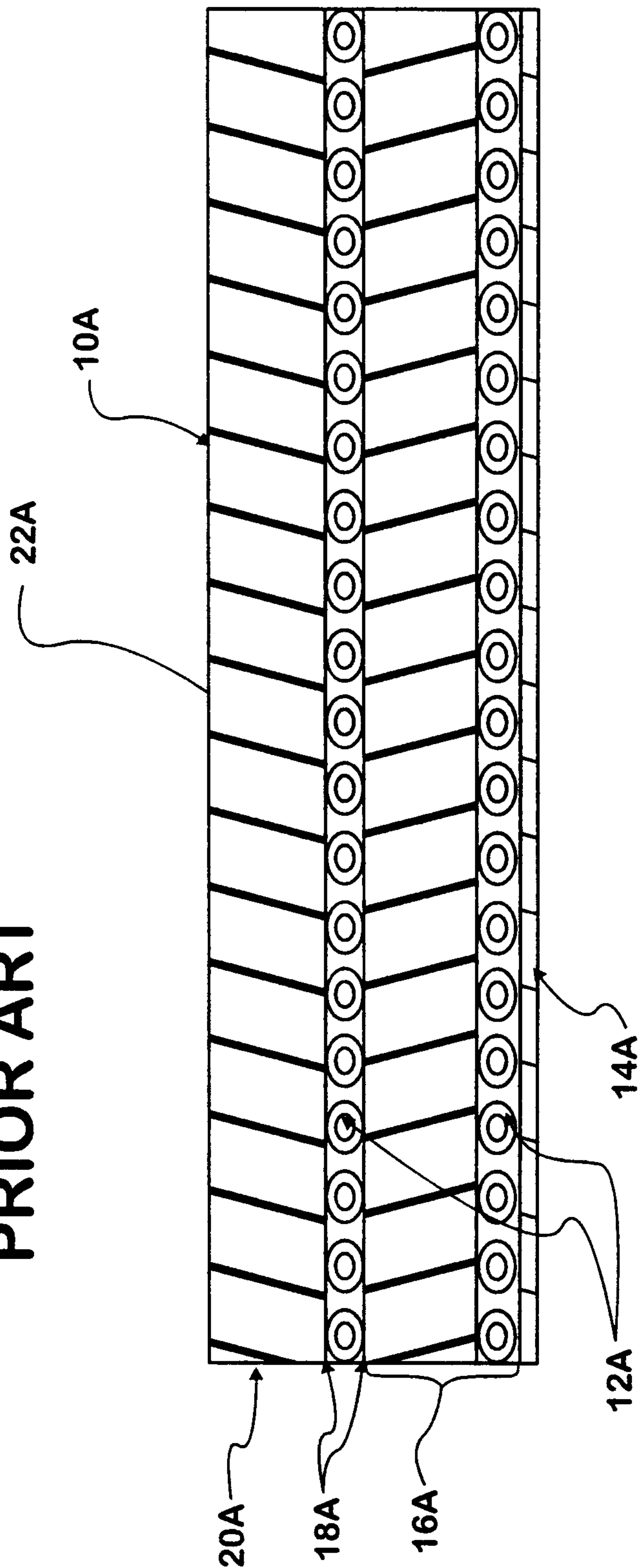

**FIG. 3**  
**PRIOR ART**

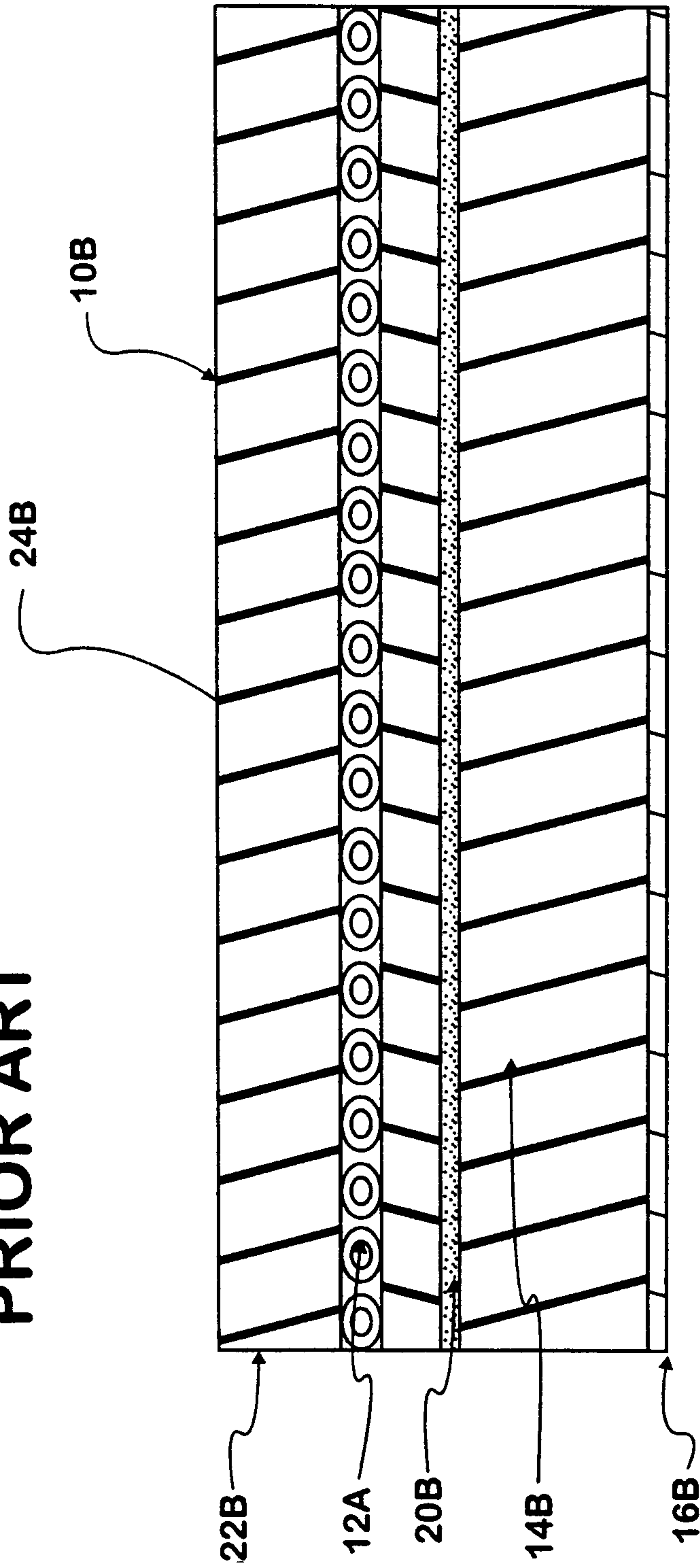

4/7

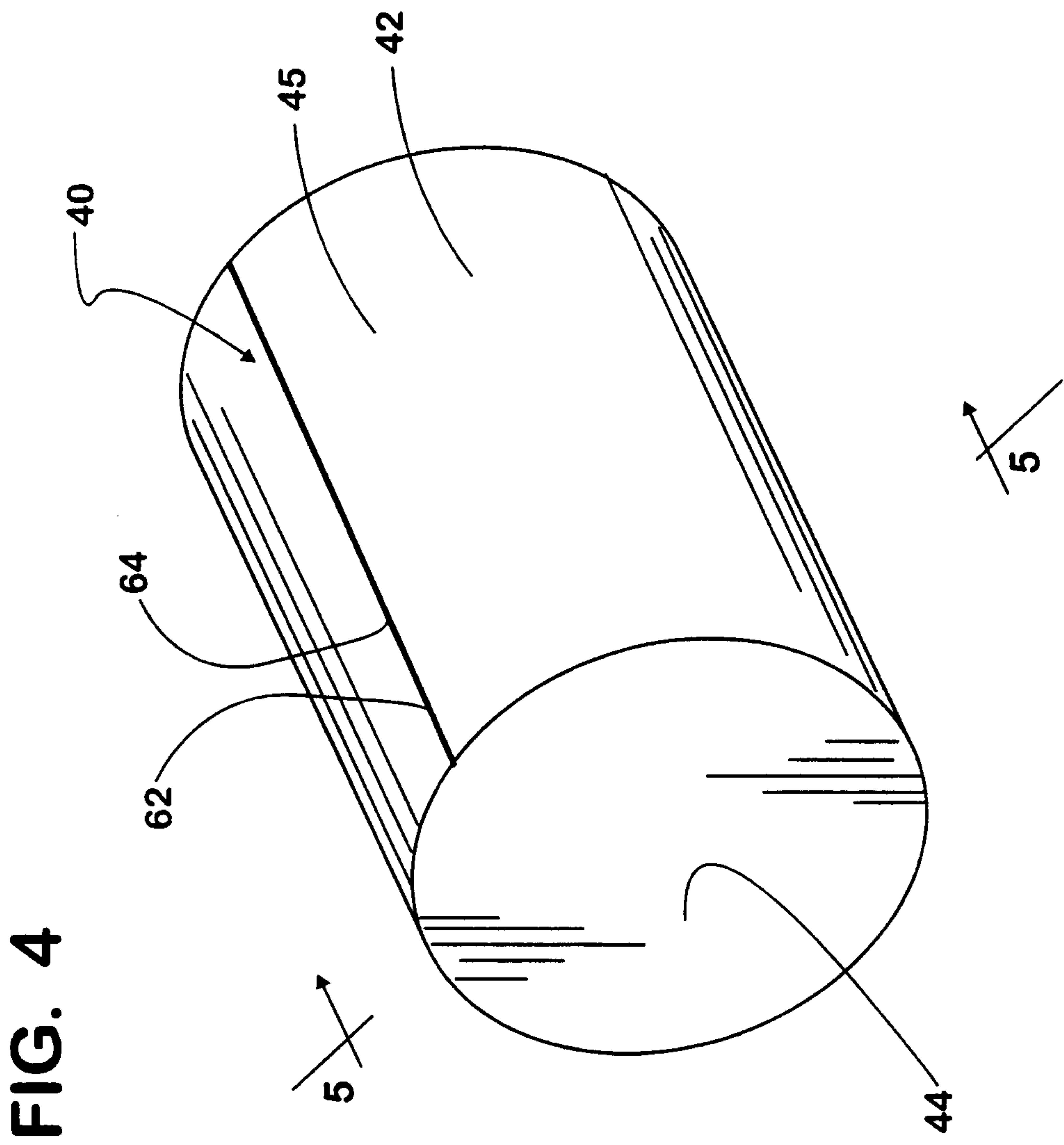
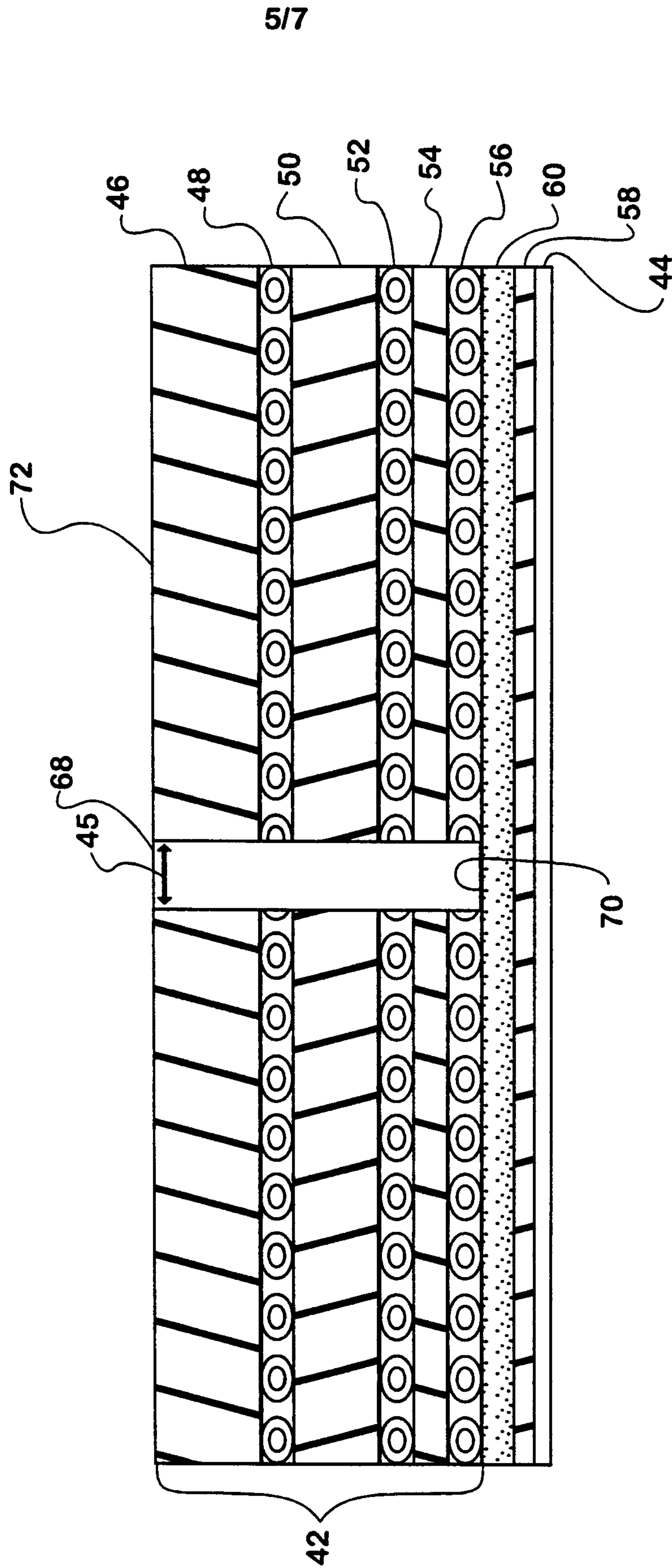

FIG. 5



SUBSTITUTE SHEET (RULE 26)

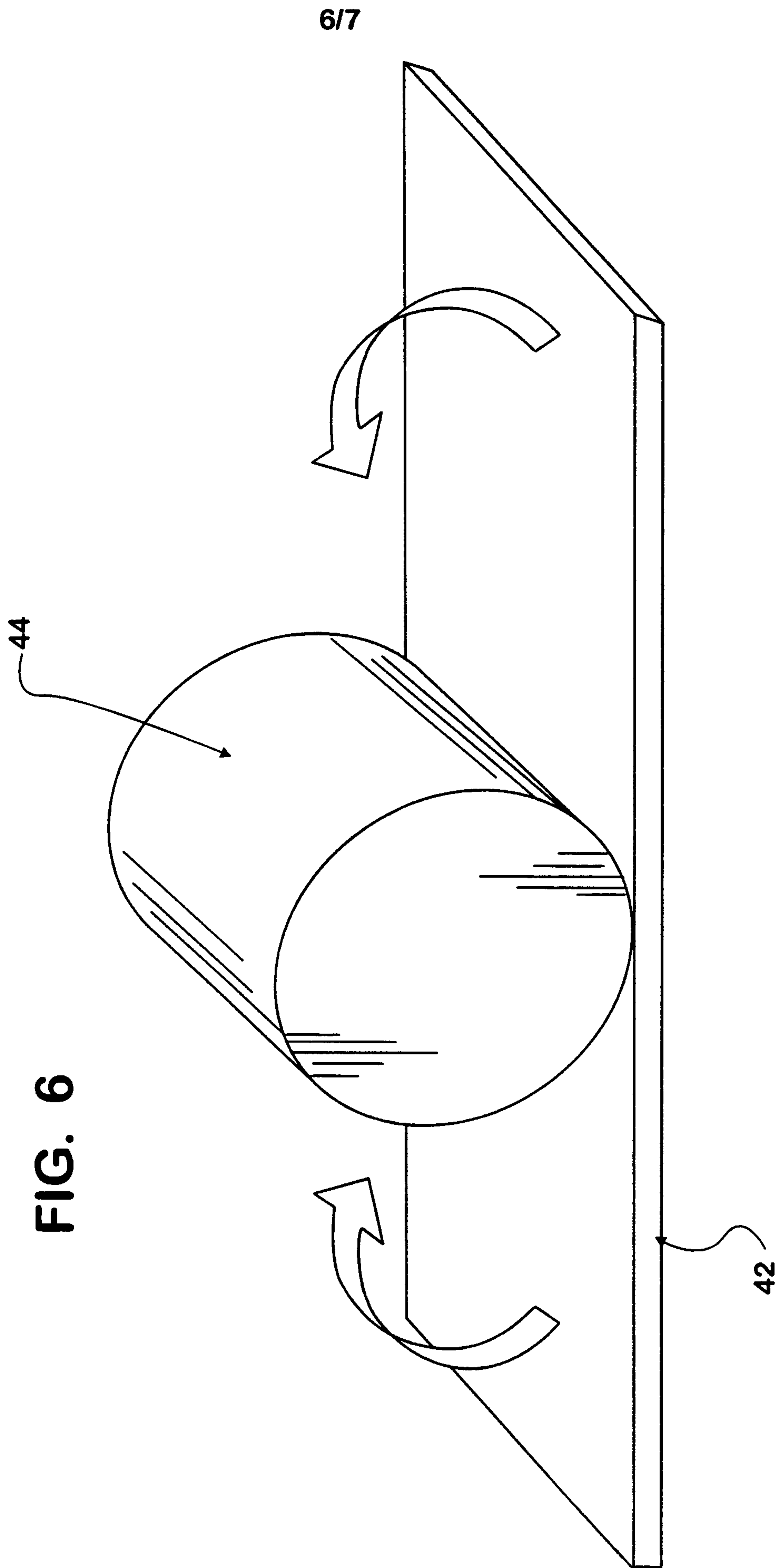

FIG. 6

717

FIG. 7

