

H. W. Safford. Hand Stamp.

No 107,964. Patented Oct. 4, 1870.

Fig; 1;

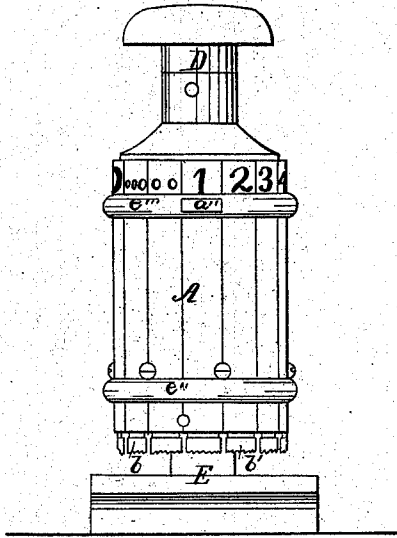

Fig; 2;

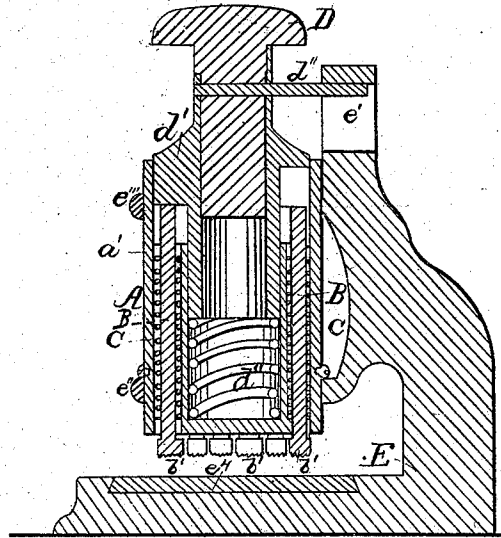

Fig; 3;

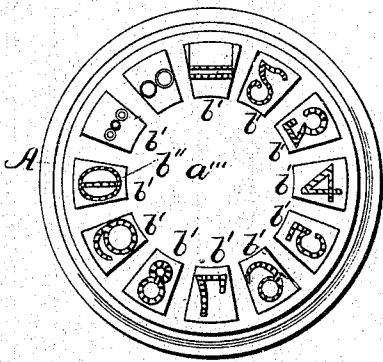

Fig; 4;

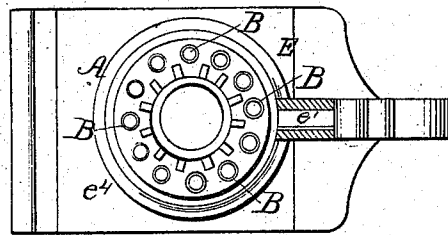

Fig; 5;

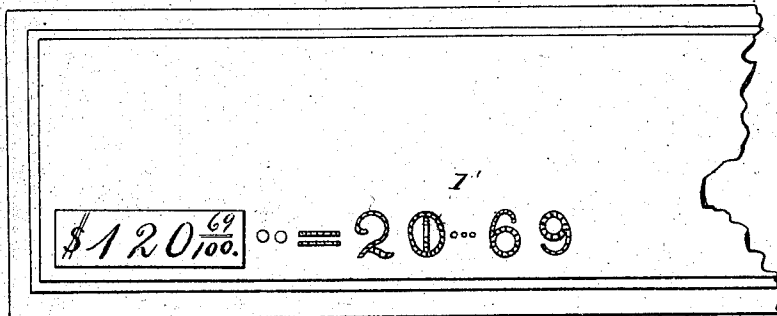

Witnesses;
James Kearney.
William Kearney.

Inventor;
H. W. Safford

United States Patent Office.

HENRY W. SAFFORD, OF NEW YORK, N. Y.

Letters Patent No. 107,964, dated October 4, 1870.

IMPROVEMENT IN HAND-STAMPS.

The Schedule referred to in these Letters Patent and making part of the same.

I, HENRY W. SAFFORD, of the city of New York, in the State of New York, have invented a certain improved Apparatus for Marking Checks, Drafts, Notes, &c., for the purpose of detecting any fraudulent alteration of the numerical amounts of the dollars and cents thereon, of which the following is a specification.

Nature and Objects of the Invention.

My invention relates to the arrangement of the cutting and piercing-dies and their springs within a hollow rotating vertical cylinder, marked on the outside with figures indicating the respective dies within, in combination with a supporting-frame and a vertically moving spring-plunger, the object of my invention being to enable the operator to readily bring the required die around in front, and cause it to produce the pierced or cut figure with facility.

Description of the Accompanying Drawings.

Figure 1 is a front elevation of the apparatus.

Figure 2 is a central vertical section of the same.

Figure 3 is an enlarged plan view of the face of the dies as they are arranged in the carrying rotating cylinder.

Figure 4 is a plan view of the upper ends of the dies and carrying cylinder, the plunger being removed.

General Description.

The cylinder A is hollow, and has a bottom, *a''*, which is provided with twelve square holes around near the sides of the cylinder for the reception of the lower ends of the stems B B of twelve shouldered blocks, which project below the said bottom, and on the lower side of these blocks the piercing and cutting figures are formed, as represented in fig. 3.

The upper parts of the stems B are cylindrical, and fit loosely in round holes in a flange, *a'*, around in the upper part of the cylinder A, and are each surrounded by a spiral spring, C, which rests upon the bottom of the cylinder and abuts at its upper end against a cross-pin in the stem, so as to hold the

shoulders of the blocks up against the under side of the bottom of the cylinder A, and at the same time allow them to be forced downward separately by an arm or projection, *d'*, on the front side of the plunger D, when the latter is forced downward upon the die-stem in front by a sudden blow of one's hand, so as to suddenly overcome the resistance of a spiral spring, *d''*, which supports it in the case A, in the usual well-known manner before used in stamp-canceling machines.

The plunger D has another arm, *d''*, projecting from its opposite side, which passes through an open slot, *e'*, in the standard of the frame E, and is thus prevented from being turned around in rotating the cylinder in its bearing-rings *e' e''*, which support it vertically on the said frame.

The figures *b'* are formed on the face of the die-blocks in series of piercing points, to represent the numerals 0 1 2 3 4 5 6 7 8 9, respectively, and two cutting-dies, which will cut clear holes through a check or draft, when forced down like the piercing-dies upon the paper, placed on a leather or other elastic support, *e''*, on the platform of the frame E.

As the two dies which make the clean-cut holes before the dollar and between the dollars and cents, respectively, for the purpose of preventing the fraudulent piercing of an additional figure to the amount of dollars, either of the two said dies will answer the purpose.

Claim.

I claim as my invention—
The arrangement of the cutting and the piercing-dies *b'*, and their springs C, within the cylinder A, in combination with the spring plunger D, and the supporting-frame and platform E, substantially as and for the purpose hereinbefore set forth

H. W. SAFFORD.

Witnesses:

JAMES KEARNEY,
CHARLES NETTLETON.