

(19) World Intellectual Property Organization  
International Bureau



(43) International Publication Date  
24 December 2008 (24.12.2008)

PCT

(10) International Publication Number  
**WO 2008/156883 A2**

(51) International Patent Classification:  
**G01B 11/06** (2006.01)

(74) Agent: **TERRANOVA, Steven, N.**; Withrow & Terranova, PLLc, 100 Regency Forest Drive, Suite 100, Cary, NC 27518 (US).

(21) International Application Number:  
PCT/US2008/057578

(81) Designated States (unless otherwise indicated, for every kind of national protection available): AE, AG, AL, AM, AO, AT, AU, AZ, BA, BB, BG, BH, BR, BW, BY, BZ, CA, CH, CN, CO, CR, CU, CZ, DE, DK, DM, DO, DZ, EC, EE, EG, ES, FI, GB, GD, GE, GH, GM, GT, HN, HR, HU, ID, IL, IN, IS, JP, KE, KG, KM, KN, KP, KR, KZ, LA, LC, LK, LR, LS, LT, LU, LY, MA, MD, ME, MG, MK, MN, MW, MX, MY, MZ, NA, NG, NI, NO, NZ, OM, PG, PH, PL, PT, RO, RS, RU, SC, SD, SE, SG, SK, SL, SM, SV, SY, TJ, TM, TN, TR, TT, TZ, UA, UG, US, UZ, VC, VN, ZA, ZM, ZW.

(22) International Filing Date: 20 March 2008 (20.03.2008)

(25) Filing Language: English

(26) Publication Language: English

(30) Priority Data:  
11/820,664 20 June 2007 (20.06.2007) US

(71) Applicant (for all designated States except US): **KOLIS SCIENTIFIC INC.** [US/US]; 1101 G Aviation Parkway, Morrisville, NC 27560 (US).

(84) Designated States (unless otherwise indicated, for every kind of regional protection available): ARIPO (BW, GH, GM, KE, LS, MW, MZ, NA, SD, SL, SZ, TZ, UG, ZM, ZW), Eurasian (AM, AZ, BY, KG, KZ, MD, RU, TJ, TM), European (AT, BE, BG, CH, CY, CZ, DE, DK, EE, ES, FI, FR, GB, GR, HR, HU, IE, IS, IT, LT, LU, LV, MC, MT, NL, NO, PL, PT, RO, SE, SI, SK, TR), OAPI (BF, BJ, CF, CG, CI, CM, GA, GN, GQ, GW, ML, MR, NE, SN, TD, TG).

(72) Inventors; and

(75) Inventors/Applicants (for US only): **KORB, Donald, R.** [US/US]; 10 Brimmer Street, Boston, MA 02108 (US). **GRAVELY, Benjamin, T.** [US/US]; 7001 Buckhead Drive, Raleigh, NC 27615 (US).

[Continued on next page]

(54) Title: TEAR FILM MEASUREMENT

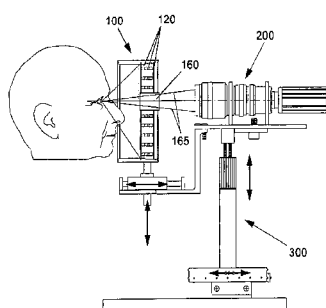

Fig. 1

(57) Abstract: The invention comprises an apparatus for measuring the relative thickness of the lipid layer component of the pre-corneal tear film on the surface of an eye after distribution of the lipid layer subsequent to blinking is disclosed. An illuminator directs light to the lipid layer of a patient's eye. The illuminator is a broad spectrum light source covering the visible region and is a lambertian light emitter such that the light source is specularly reflected from the lipid layer and undergoes constructive and destructive interference in the lipid layer. A collector collects and focuses the specularly reflected light such that the interference patterns on the tear film lipid layer are observable. The collector also produces an output signal representative of the specularly reflected light which is suitable for further analysis, such as projection on to a high resolution video monitor or analysis by or storage in a computer. In order to facilitate ease of measurement, the patient's head may be positioned on an observation platform when the illuminator directs light to the lipid layer of the patient's eye.

WO 2008/156883 A2



**Published:**

- *without international search report and to be republished upon receipt of that report*

## TEAR FILM MEASUREMENT

### FIELD OF THE INVENTION

This invention relates generally to the field of measurement of the tear film thickness on the precorneal surface of the eye and more particularly, to the measurement of the thickness of  
5 the outermost layer of the tear film, i.e., the lipid layer.

### BACKGROUND OF THE INVENTION

The human precorneal tear film is comprised of three primary layers, each of which serves a specific function. The innermost layer of the precorneal tear film provides a protective  
10 environment for the superficial epithelial cells of the cornea and helps protect against microbes and foreign bodies. The outer surface of the precorneal tear film is the primary refracting surface of the eye. Its surface tension helps to smooth this surface, thus improving the optical quality of the image ultimately impacting the retina. Additionally, the precorneal tear film provides a lubricating function during blinking. These structures are often disrupted in dry eye conditions,  
15 which are some of the most common ophthalmic disorders seen by eye-care practitioners. Dry eye disorders and/or disease can lead to premature breakup of the tear film after a blink, leading to damage of the superficial epithelium which may result in discomfort and be manifested as optical blur. In addition, the ability of a patient to wear contact lenses is a direct function of the quality and quantity of the tear film, and dry eye disorders and/or disease therefore has a  
20 significant impact on contact lens wear parameters.

The precorneal tear film is comprised of an inner mucin layer, a middle aqueous layer, and an outermost thin lipid layer. Various treatments are used in an attempt to alleviate dry eye symptoms. For example, it has been proposed to treat certain dry eye conditions by the

application of heat and pressure to unclog meibomian glands, or with pharmaceutical methods to unclog meibomian gland and to stimulate tear production.

Notwithstanding the foregoing, it has been a long standing and vexing problem for clinicians and scientists to objectively demonstrate an improvement in the precorneal tear film thickness at the conclusion of the proposed treatment. Further, many promising treatments for dry eye have failed to receive approval from the United States Food and Drug Administration due to the inability to demonstrate clinical effectiveness to the satisfaction of the agency.

In response to the foregoing long felt need, various methods of measuring the thickness of the precorneal tear film, and specifically the lipid layer thereof have been proposed. For example, Korb, one of the inventors of this invention provided an overview and background of his invention of a specular reflection microscope system that allowed quantification of the tear film lipid layer thickness based on the interference colors of the lipid layer. This system included a hemi-cylindrical broad spectrum illumination source with heat absorbing filters, a binocular microscope with a Zeiss beam-splitter providing 70% light to a high resolution video camera, a VHS recorder, and a high resolution 20-inch color monitor. Following calibration with Eastman Kodak color reference standards (Wratten filters), the static and dynamic appearance of the lipid layer was observed before and after blinking. During the observation period, the subject was instructed to blink naturally while gazing at a fixation target. For purposes of quantization and standardization, a specific region of the tear film was designated for analysis. This area encompassed a zone approximately one mm above the lower meniscus to slightly below the inferior pupillary margin, averaging 7-8 mm wide and 2.5 mm in height. The dominant color of the specularly reflected light within this designated area was used as the basis for assigning lipid layer thickness values. Thickness values were assigned to specific

colors on the basis of prior work on tear film lipid layer interference colors (McDonald, 1969; Nom., 1979; Guilon, 1982; Hamano et al., 1982) and are summarized in Table 1. To confirm the lipid layer thickness values assigned to each subject's tear film lipid layer, recordings were independently graded by two observers masked as to subject identity. (Korb, DR, Baron DF, 5 Herman JP, et al., Tear Film Lipid Layer Thickness as a Function of Blinking, *Cornea* 1994:13:354-9). While the foregoing apparatus was effective in measuring improved lipid layer thickness, measurement inaccuracies were nevertheless introduced into the system. Working backwards, the color monitor had to be provided with a sufficient input signal to enable the lipid layer to be imaged on to the monitor screen. The foregoing thus required a minimum 10 illumination to be provided to the slit lamp, of which 70% was directed to the high resolution video camera. This, in turn, dictated the minimum amount of light required to illuminate the corneal surface. Thus, the amount of light required to make the foregoing system operational was not optimum as it interfered with the naturally occurring tear film as the heat generated by the light caused tear film evaporation. Further, the amount of light required to make the system 15 functional caused some degree of reflex tearing.

Another apparatus for measuring the tear film is disclosed in European Patent Application EP 0 943 288 assigned to Kowa Company, Ltd. of Japan. The application discloses an apparatus for the non-contact measurement of the quantity of lacrimal fluid collected on the lower eyelid. According to the invention, tear volume is calculated from a measurement of the 20 volume of fluid pooled at the lid eye meniscus. While knowledge of the total volume of fluid may be of some use to eye-care practitioners, it does not specifically measure the lipid layer thickness or its improvement as the result of a particular treatment regimen.

US Patent No. 4,747,683 to Marshall G. Doane discloses a Method and Device for in Vivo Wetting Determinations wherein a contact lens is illuminated with coherent light and the pre-lens tear film is imaged in such a way as to form an interference pattern. The image formed thereby is recorded and the tear film thickness is determined by correlating the interference

5 bands of the recorded image. A coherent light source and a camera are focused at the pre-lens film to image specularly reflected light from the front and rear surfaces of the tear film. A film motion analyzer provides numerical coordinates of interference bands, and a microprocessor analyses the coordinates to provide a quantitative measure of lens position or wetting characteristics. Again, while knowledge of the tear film thickness covering the contact lens

10 surface may be useful in the context of contact lens fitting, the Doane apparatus does not specifically measure lipid layer thickness on the natural eye.

Another instrument that purports to measure tear film lipid layer thickness is the Tearscope Plus manufactured by Keeler Instruments Inc., of Broomall, PA and Berkshire, UK. More specifically, the Tearscope is a hand-held or slit lamp mounted device that comprises a

15 tubular housing which contains a coaxially mounted cylindrical light source. The interior bore of the housing is covered with a cylindrical diffuser plate that diffuses the light. In use, the eye-care practitioner places one end of the tube proximate the patient's eye thus illuminating the whole eye, including the pupil, and observes the interference patterns on the pupil surface through the opposite end of the tube. The color of the interference pattern generated by blinking

20 is then correlated to tear film thickness. The Tearscope is not without its inherent drawbacks and deficiencies as the process by which the eye is illuminated and the measurement is made introduces error which is diagnostically unacceptable. For example, the proximity of the illuminator to the eye surface when combined with the light intensity required to obtain a

viewable interference pattern can cause reflex tearing. In addition, the illumination system employed illuminates the entire eye, including the pupil. Thus, light from the Tearscope is directed on to the retinal surface which, in turn causes a proprioceptive response which also skews measurement accuracy.

5 In view of the foregoing, it is an object of the present invention to provide a method and apparatus that overcomes the drawbacks and deficiencies of the prior art.

Another object of the present invention is to provide a method and apparatus that allows the accurate measurement of the thickness of the lipid layer component of the precorneal tear film.

10 A further object of the present invention is to provide a method and apparatus wherein the lipid layer thickness of the precorneal tear film may be measured without the introduction of reflex tearing.

A still further object of the present invention is to provide a method and apparatus that enhances contrast and thereby the observability and measurability of the lipid layer thickness of the precorneal tear film.

15

Yet another object of the present invention is to provide a method and apparatus for measuring the lipid layer thickness of the precorneal tear film using a low level of light in order to minimize tear film evaporation that can alter the measurement..

Another object of the present invention is to provide a method and apparatus for measuring the lipid layer thickness of the precorneal tear film wherein the patient is comfortable during the examination.

20

Another object of the present invention is to provide a method and apparatus for measuring the lipid layer thickness of the precorneal tear film that minimizes light entering the pupil to minimize reflex tearing and proprioceptive responses that can alter the measurement.

## 5 SUMMARY OF THE INVENTION

In accordance with the foregoing, the invention comprises an apparatus for measuring the thickness of the lipid layer component of the precorneal tear film on the surface of an eye after distribution of the lipid layer subsequent to blinking. An illuminator directs light to the lipid layer of a patient's eye. A means for observing the specularly reflected light rays is provided.

10 The illuminator is a broad spectrum, large area lambertian light source covering the visible region, the rays of which are specularly reflected from the lipid layer and undergo constructive and destructive interference in the lipid layer. A collector such as a camera or slit lamp may be provided to collect and focus the specularly reflected light such that the interference patterns on the tear film lipid layer are observable. The collector also produces an output signal  
15 representative of the specularly reflected light which is suitable for further analysis, such as projection on to a high resolution video monitor or analysis by or storage in a computer.

Alternatively, the interference patterns of the specularly reflected light may be directly observed by the clinician and recorded. In order to facilitate ease of measurement, the patient's head may be positioned on an observation platform, for example, a slit lamp stand, when the illuminator  
20 directs light to the lipid layer of the patient's eye.

In a first embodiment of the invention, the illuminator is sized to show the interference pattern of the lipid layer over the whole eye, (termed herein the "whole eye illuminator"), with



the provision that the intensity of the light entering the pupil and striking the retina are below the threshold at which appreciable measurement error is introduced, i.e., the reflex tear and proprioceptive responses are not activated. Observation of the interference pattern in the preferred embodiment is through an opening in the illuminator.

5           In a second embodiment of the invention, the illuminator is sized to show the interference pattern of the lipid layer below the pupil, (termed herein the “half eye illuminator”), such that the intensity of the light entering the pupil is extremely low, thus avoiding the introduction of virtually all system-induced inaccuracy. Observation of the interference pattern in this second embodiment is from above the illuminator.

10

#### BRIEF DESCRIPTION OF THE DRAWINGS

These and other features will be understood with reference to the figures, in which

Figure 1 is a side view of the tear film analyzer according to the present invention mounted to a stand with a patient positioned for viewing of interference fringes on the lipid layer  
15 of the eye. The illuminator portion is shown as a vertical cross section through the center.

Figure 2 is a plan view of the tear film analyzer according to the present invention mounted to a stand with a patient positioned for viewing of interference fringes on the lipid layer of the eye.

Figure 3a is a side view of a second embodiment of the tear film analyzer according to  
20 the present invention mounted to a stand with a patient positioned for viewing of interference fringes on the lipid layer of the eye. The illuminator portion is shown as a vertical cross section through the center.

Figure 3b is a side view of the second embodiment of the tear film analyzer according to the present invention mounted to a stand and tilted with a patient positioned for viewing of interference fringes on the lipid layer of the eye. The illuminator portion is shown as a vertical cross section through the center.

5           Figure 4a is a plan view of the second embodiment of the tear film analyzer according to the present invention mounted to a stand with a patient positioned for viewing of interference fringes on the lipid layer of the eye.

          Figure 4b is a plan view of the second embodiment of the tear film analyzer according to the present invention mounted to a stand and tilted with a patient positioned for view of  
10 interference fringes on the lipid layer of the eye.

          Figure 5a is a plan view of the second embodiment of the tear film analyzer according to the present invention illustrating the illuminator surface that produces the outer edges of the viewable area of interference fringes.

          Figure 5b is a side view of the second embodiment of the tear film analyzer according to  
15 the present invention illustrating the illuminator surface positioned below the plane of the pupil and tilted at an angle and showing the outer edges of the viewable area of interference fringes.

          Figure 5c is a side view of the second embodiment of the tear film analyzer according to the present invention illustrating the illuminator surface vertically positioned below the plane of the pupil and showing the outer edges of the viewable area of interference fringes.

20           Figure 6 is a perspective view, partially exploded, of the full eye illuminator according to the present invention.

          Figure 7 is a plan view, sectioned horizontally through the center of the viewing hole of the full eye illuminator according to the present invention.

Figure 8 is an end view, sectioned vertically through the center of the full eye illuminator according to the present invention.

Figure 9 is a perspective view, partially exploded of the half eye illuminator according to the present invention.

5 Figure 10 is a plan view with the top removed of the half eye illuminator according to the present invention.

Figure 11 is an end view, sectioned vertically through the center of the half eye illuminator according to the present invention.

10 Figure 12 is a front view of the surface of an eye and illustrating schematically the area defined by the extreme lambertion rays wherein interference patterns are viewable.

#### DETAILED DESCRIPTION OF THE PREFERRED EMBODIMENTS

While the present invention will be described more fully hereinafter with reference to the accompanying drawings, in which particular embodiments are shown, it is to be understood at 15 the outset that persons skilled in the art may modify the invention herein described while still achieving the favorable results of this invention. Accordingly, the description which follows it to be understood as a broad teaching disclosure directed to persons of skill in the appropriate arts and not as limiting upon the present invention.

20 In a first embodiment best shown in figures 1, 2 and 6-8, referred to herein as the "full eye illuminator" the apparatus according to the present invention broadly comprises an illumination means 100 and a means for observing the specularly reflected light 200. A second embodiment best shown in figures 3a, 3b, 5a-5c and 9-11, referred to herein as the "half eye" illuminator is shown. The mode of operation of the two embodiments is substantially identical

and they will therefore be described together using the same reference numerals and where differences between the embodiments occur, they will be discussed.

The illumination means 100 for directing light to the lipid layer of the patient's eye comprises a large area broad spectrum light source covering the visible region and being a  
 5 lambertian emitter adapted to be positioned in front of the eye on a stand 300. As employed herein the terms "lambertian surface" and "lambertian emitter" are defined to be a light emitter having equal intensity in all directions. The light source comprises a large surface area emitter, arranged such that rays emitted from the emitter are specularly reflected from the lipid layer and undergo constructive and destructive interference in the lipid layer. An image of this surface is  
 10 the backdrop over which the interference image is seen and it should be as spatially uniform as possible. The illumination means 100 illuminates a large area of the face which creates a 2.5mm high by 5mm long viewable area centered beneath the pupil 310 (see figure 12) which is adequate for lipid layer thickness determination and correlation to dry eye. By "viewable area" it is meant the active area that satisfies the criteria for viewing interferences fringes; i.e.,  
 15 approximately 2.5 mm x 7 mm for the half eye illuminator. Full-eye illumination, excluding the pupil area, reveals additional information about the whole eye pattern of lipid distribution.

The geometry of the illuminator 100 can be most easily understood by starting from the camera lens and proceeding forward to the eye and then to the illuminator. The fundamental equation for tracing ray lines is Snell's law:

20 1)  $N_1 \sin \theta_1 = N_2 \sin \theta_2,$

where N is the refractive index of the medium containing the ray, and  $\theta$  = the angle of the ray relative to the normal from the surface. For a reflected ray that doesn't enter the lipid layer,  $N_1 = N_2,$  and

2)  $\theta_1 = \theta_2$ .

Under these conditions, Snell's law reduces to the classical "angle of incidence is equal to the angle of reflectance" statement.

According to the present invention, it is necessary to determine only the extreme rays (the ones at the outermost boundary of the desired viewing area) to define the area of the illuminator. Since the surface of that portion of the eye to be examined is approximately spherical, a line drawn from the camera lens (or the observer's eye) to the edge of the viewing area on the observed eye will reflect at the same angle on the other side of the line normal to the eye surface at the point of intersection of the line with the eye. When the half eye illuminator used, it may be tilted to better accommodate the nose and illuminate a larger area of the inferior lipid layer. Notwithstanding the foregoing, experimentation using the half eye illuminator has shown that a tilt of 10° to as much as 30° is still functional. Returning now to the full eye illuminator, as best shown in Figures 1 and 2, it will be seen that facial features block some rays from reaching the surface of the eye. The nose, cheeks, eyebrows, and eyelids block rays, causing shadows on the eye surface. Positioning the illuminator for maximum area exposure is unique to each patient's facial structure. The mechanical dimensions (height and width) of the illuminator may be extended to cover the biometric range of facial features of the target population.

The illumination means 100 is a broad spectrum light source covering the visible region between about 400 nm to about 700 nm. In the model that was constructed, high efficiency, white Light Emitting Diodes ("LEDs") were used that have a 50° forward projection angle, 2500mcd typical intensity, and 5mm diameter (part number NSPW510CS, available from Nichia Corporation, Wixom, MI). Other LEDs could be added to the present invention to enhance the spectral width in the near UV or near IR regions. The light emitting array platform 130 (Figs. 6,

7) into which the LEDs are mounted had a curved surface, subtending an arc of approximately 130° from the optical axis of the eye (see Fig 5a). Approximately 96 LEDs spaced apart in a grid pattern with 6 rows and 16 columns were connected in parallel/series combinations and connected to an appropriate power supply, well known to those skilled in the art and therefore, not shown. A housing is formed around the LED array platform 130 by a pair of side panels 135, bottom and top panels 140, rear panel 145 and the diffuser means or diffuser 150. The respective diffuser 150, LED platform 130, and rear panel 145 are flexible and fit within grooves 147 located in the top and bottom panels 140 and the end pieces 135. The entire assembly is snapped together and the side panels 135 are then screwed to top and bottom panels 140. While the illumination means 100 illustrated in the figures is curved or arcuate and has a radius of 7.620 inches from the center of the eye under examination, it could be flat as long as it subtends 130° around the eye. A curved surface is more efficient in doing this, as the geometry yields a smaller device which is easier for the practitioner to use in a clinical setting.

The total power radiated from the illuminator 100 must be kept to a minimum to prevent accelerated tear evaporation. In addition, air currents generated by heating or cooling systems can also cause excess evaporation and must be minimized (preferably eliminated) to maintain measurement accuracy. The brightness, or intensity, measured in  $\mu\text{W}/\text{mm}^2$ , entering the pupil can cause reflex tearing, squinting, and other visual discomforts, all of which affect measurement accuracy. For a full-eye illuminator, the curved lambertian emitter includes a centrally positioned hole defining an opening 160 through which the means for collecting and focusing the specularly reflected light, i.e., a camera, eye, or other lens 200, is positioned. The opening 160 in the center substantially prevents direct illumination from entering the pupil of the test eye. While less than optimal, the opening 160 could be located in other parts of the illuminator. The

other eye, however, has the full light intensity entering the pupil. If the illumination intensity is low enough, the exposed eye does not react. The exposed eye may also be occluded with a mask, or the illuminator may be segmented so that parts of the surface are not illuminated. The half-eye illuminator stops below the centerline of the eye and does not directly illuminate either pupil or stated otherwise, light rays can only enter the pupil obliquely and do not impinge on the retina. The current full-eye illuminator has a brightness or illumination intensity of between about  $3\mu\text{W}/\text{mm}^2$  and  $15\mu\text{W}/\text{mm}^2$  with about  $4.5\mu\text{W}/\text{mm}^2$  at the surface of the illuminator being preferred, which is held 1-2 inches from the eye. The total radiated power is less than 1W and preferably no more than 400mW. Brightness above about  $6\mu\text{W}/\text{mm}^2$  becomes uncomfortable to the second eye if it enters the pupil so as to impinge directly on the retina. The front surface of the illuminator is the lambertian emitter, i.e., all points on the extended illuminator surface are lambertian emitters, and comprises a flexible white translucent acrylic plastic sheet approximately 1/16 inch thick that serves the function of diffusing the light emitted from a plurality of LED point sources and transforming them into the uniform Lambertian emitter.

In order to prevent alteration of the proprioceptive senses and reduce heating of the tear film, it is important to minimize the incident power and intensity on the eye and thus, the means for collecting and for focusing the specularly reflected light such as a high sensitivity color camera 200 should be employed. The video camera, slit lamp or other observation apparatus 200 is positioned in opening 160 and is also mounted on stand 300 as shown in figure 2 or in the case of the half eye illuminator positioned above the emitter as per figures 3a and 3b. Detailed visualization of the image patterns requires a means for collecting the specularly reflected light and for focusing the specularly reflected light such that the interference patterns from the lipid

layer are observable. Good digital imaging requires a CCD video camera having a resolution of up to 1280 x 1024 pixels and at least 15 Hz frame rate to show the progression of lipid interference patterns as they spread across the eye. The AVT Dolphin 145C, 2/3 inch, CCD camera with  $6.45\mu\text{m}^2$  pixels meets the requirements and outputs a signal representative thereof which may serve as the input signal to any one of a number of devices such as a video monitor (preferably high resolution) or a computer for analysis and/or archiving purposes.

The lens system employed in the instant tear film analyzer images a 15 - 40mm dimension in the sample plane (the eye) onto the active area of the CCD detector (e.g. ~10mm horizontal dimension for a 2/3 in. CCD). The lens f-number should be as low as practical to capture maximum light and minimize the illumination power needed for a good image. The lens chosen for the half-eye and full-eye systems is the Navitar Zoom 7000 close focus zoom lens for 2/3in. format CCDs. At lower magnification (25-40mm field of view), the eye and lids can be examined to observe the relationship of the blink to the lipid layer thickness. A more detailed analysis of the lipid layer can be obtained with a slightly higher magnification showing a 15-25mm field of view.

The lipid layer thickness is not uniform and is classified on the basis of the most dominant color present in the interference pattern. It is believed that the lipid layer for most individuals cannot exceed 180 nm, and since thicker lipid layers provide better protection from evaporation than thinner lipid layers, thicker lipid layers provide greater protection against the development of dry eye states. Thinner lipid layers are associated with dry eye states and dry eye symptoms, particularly if the lipid layer thickness is less than 75nm.

The present system displays the interference patterns from white light incident on the lipid layer film. The relation between the colors of the interference pattern and the lipid layer



thickness (LLT) are shown in Table 1.

<b>Color</b>	<b>LIPID LAYER THICKNESS (nm)</b>	<b>Letter Grade</b>
Blue	180	A
Blue/Brown	165	A-
Brown/Blue	150	B+
Brown	135	B
Brown/Yellow	120	B-
Yellow/Brown	105	C+
Yellow	90	C
Grey/Yellow	75	C-
Grey	60	D+
Grey/White	45	D
White	30	F

Table 1

5 Extensive research has established that thicker films are indicated by a blue and brown color, mid-thickness films are indicated by a yellow color, thinner films are indicated by a grey-  
yellow color, and very thin films exhibit a gray scale of different densities with white  
representing the thinnest. It is believed in color photometry, brown can be obtained in an  
additive process by mixing small intensities of red and green, or orange and blue, basically the  
10 opposite ends of the visible light spectrum. Alternatively, brown can be obtained in a subtractive

process by filtering out the central yellow-green colors from the white spectrum, leaving a blue-orange mix.

It has not been verified why the wavelengths of light observed in the interference film are inverse to the film thickness, but extensive clinical testing has led the inventors to the belief and the theory that destructive interference is the dominant process. The closer the wavelength is to the film thickness, the greater the interference, so yellow-red interference will have the strongest effect in a thicker film. However, thicker films appear blue, so it is postulated that red wavelengths are removed from the incident light spectrum by destructive interference and the reflected light appears blue.

For a thinner film, blue will have a stronger interference. Since the thinner films appear reddish, it is assumed that the blue is removed by destructive interference. From this, we assume that the color seen is the broadband surface reflection with the dominant interference color band removed. That is, interference subtracts the portion of the spectrum indicative of the film thickness from the reflected light, leaving the complementary colors. This is the best explanation known to the inventors of how brown is obtained from a system of this type. Table 1 lists the colors of the visible spectrum and their respective wavelengths.

It must be noted that the thickness of the lipid layer on the eye is much smaller than all the wavelengths of visible light. Therefore, full wavelength interference patterns are believed not to be possible. For fractional wavelengths, ( $\lambda/2n$ ,  $n=1,2,\dots$ ) the intensity in the interference pattern decreases rapidly as  $n$  increases and the ability to differentiate weak interference patterns from the background decreases accordingly.

When the lipid film thickness falls below about 90nm, no color is seen in the image generated by the present apparatus (employing the current LED light source), only gray of

varying density. It is presumed that violet and ultraviolet interference effects predominate at this thickness, but since they are absent from the incident spectrum, no color can be seen. Any interference remaining over the visible light spectrum is so weak due to the very small fraction ( $\lambda/2n$ ,  $n>5$ ) that full-spectrum reflection and absorption effects dominate and no particular color  
5 can be seen. Broadband destructive interference in the 60-75nm layers gives way to broadband constructive interference at the thinnest layer ( $\leq 30$ nm).

In summary, it is believed that the present invention demonstrates the results of subtractive colors, where subtracting the blue end from white light leaves a reddish tint, subtracting the center (yellow-green) from the spectrum leaves a brownish tint, and subtracting  
10 orange-red leaves a blue tint. Because all the interference patterns are fractional wavelengths, and therefore relatively weak in intensity, the images are not strongly saturated. Image enhancement techniques therefore assume a higher importance for good visibility. Film thickness below about 90nm can be determined by gray scale analysis.

Should the use of real time or high speed data transfer and large storage volumes be  
15 required for a given application, the use of a means for recording the output signal representative of the specularly reflected light (video output signal) such as a high performance computer system would be needed. As employed herein, the term "real time" is defined as data transfer, storage and retrieval at a rate required for image generation that the observer requires for a subjectively satisfactory viewing experience. For viewing the motion of the lipid layer  
20 interference pattern after blinking a minimum of about 15 frames per second is satisfactory for seamless motion perception. Depending upon settings, the camera can create 1.4-3.9MB images at 15 per second, or 21-57MB/sec which must be processed by the computer for storage, display, or computation. At this rate, one minute of recording requires 1.26-3.42GB of storage. Given

the presently available technology, it is not reasonable to store recording sessions in RAM, so the data from the camera must be streamed directly to a storage system sized to meet the anticipated volume of data. For example, 500 GB of storage could record 147-397 tests of one minute duration. Various forms of data management could be applied to reduce the storage requirements, including image size, compression, and minimizing recording time adequate to good diagnostics.

The software to operate the camera, capture the images, store and retrieve image files, and execute chosen calculations on the data is critical to the success of the system. Relevant specifications are:

10 The mechanical system consists of components to position the patient's head, position the illuminator and camera, focus the camera, and switch position between eyes.

Current ophthalmic chin rests are adequate for positioning and restraining the head. They include vertical (Z axis) adjustment.

A movable frame positions the camera and illuminator opposite the patient's face. The illuminator and camera move together in a gross manner, but the illuminator has an independent X and rotational motions for accommodating different facial geometries. Switching from eye to eye requires moving the whole camera/illuminator frame away from the patients face (X motion) and horizontally to line up with the second eye (Y motion). Focusing the camera requires fine control of X motion, and vertical Z motion is required to accommodate differences in patient eye positions. A classical slit lamp biomicroscope stand incorporates most of these motions, and have added angular motions not needed in the present system.

20 Figures 1, 2, 3a-3c illustrate the full-eye system. A typical examination session proceeds as follows:

Presets: The vertical relationship between the camera and the illuminator is set. For a half-eye illuminator, the camera position is just enough higher than the illuminator top edge that the image contains no edge effects. When using the full-eye illuminator, the camera is positioned coaxially with the hole through the illuminator. The camera/illuminator position should not need adjusting thereafter.

Patient examination:

1. The patient is seated and asked to place their chin on the chin rest. The chin rest is adjusted (Z axis) for the comfort of the patient. The patient is asked to hold their forehead against the forehead rest.
2. The frame holding the camera & illumination is positioned on the axis of the first eye and brought close enough for rough focus on the skin.
3. The frame is adjusted for vertical and horizontal centering, and then moved forward for fine focusing.
4. The illuminator is adjusted forward and back, and rotated for best illumination of the eye. Repeat fine focus as necessary. The patient is asked to look directly at the center or top center of the camera lens. Instructions are given to the patient for blinking regimens by the diagnostician.
5. The images are viewed and recorded as desired.
6. The frame may be pulled away from the patient (to clear the nose) and moved horizontally to the next eye. Steps 2.-5 are repeated.

The system could be fully motorized and operated in manual, semi-autonomous, or autonomous modes, depending upon the sophistication of the control software. A fully automatic system would adjust the mechanical stand, focus the camera, record the motion of the lipid film, calculate various measurements of the film structure, report an assessment of the quality of the lipid film, and record the data in the patient's record file.

The invention having been thus disclosed, diverse changes and variation in the apparatus and method will occur to those skilled in the art, and all such changes and modifications are intended to be within the scope of the invention, as set forth in the following claims:

**In the Claims:**

- 5 1. An apparatus for measuring the thickness of the lipid layer on the surface of a patient's eye after distribution of the lipid layer subsequent to blinking comprising:  
an illuminator that directs light to the lipid layer of a patient's eye, the illuminator comprising a broad spectrum light source in the visible region being a lambertian emitter such that the rays from the light source are specularly reflected from the lipid layer and undergo  
10 undergoes constructive and destructive interference in the lipid layer; and  
an imaging device for observing the specularly reflected light such that the interference patterns on the tear film lipid layer are observable.
- 15 2. The apparatus according to claim 1 wherein said illumination means comprises an arcuate emitter and wherein the surface of said lambertian emitter is substantially parallel to the surface of the eye.
- 20 3. The apparatus according to claim 1 wherein said means for observing the specularly reflected light comprises a hole defining an opening in the illumination means.
4. The apparatus according to claim 3 wherein said opening in the illumination means  
25 allows for observation of the specularly reflected light from behind said illumination means.
5. The apparatus according to claim 3 further including a means for collecting and focusing the specularly reflected light and for generating an output signal representative thereof  
30 operatively associated with said opening.

6. The apparatus according to claim 5 further including means for recording the output signal representative of the specularly reflected light.

5

7. The apparatus according to claim 6 wherein said means for recording the output signal representative of the specularly reflected light records in real time.

10

8. The apparatus according to claim 5 wherein said means for collecting and focusing the output signal comprises a camera lens system.

15 9. The apparatus according to claim 6 wherein said means for recording is selected from the group of recording devices consisting of computer memory, video cassette recording devices, analog recording devices and digital recording devices.

20 10. The apparatus according to claim 1 wherein said specularly reflected light is observed when the patient's head is positioned on an observation platform.

11. The apparatus according to claim 2 wherein said arcuate emitter is constructed and  
25 arranged such that the light rays emitted therefrom strike the surface of the eye such that Snell's Law is satisfied with respect to the acceptance angle of said means for observing the specularly reflected light and produces an observable area of interference on the surface of the eye.

30

12. The apparatus according to claim 1 wherein said illumination means further includes a plurality of spaced apart light emitting diodes adapted to emit light in the visible region; and a diffuser means for diffusing the light emitted by the respective light emitting diodes positioned between said light emitting diodes and the surface of the eye and further, wherein  
5 the diffuser means is arcuate such that the light rays emitted therefrom strike the surface of the eye such that Snell's law is satisfied with respect to the acceptance angle of said camera lens system so as to produce an observable area of interference on the eye.

10 13. The apparatus according to claim 11 wherein the light rays that generate the visible viewing area of interference are substantially normal to the surface of the eye.

14. The apparatus according to claim 1 wherein said illumination means has a total radiated  
15 power of less than 1 W.

15. An apparatus for measuring the thickness of the lipid layer on the surface of an eye after distribution of the lipid layer subsequent to blinking comprising:

20 an illuminator that directs light to the lipid layer of a patient's eye, the illuminator being a broad spectrum light source in the visible region and being a lambertian emitter such that the light source is specularly reflected from the lipid layer and undergoes constructive and destructive interference in the lipid layer and wherein the total light emitted from the surface of the illumination means is less than  $10 \mu\text{W}/\text{mm}^2$ ; and

25 an imaging device for observing the specularly reflected light such that the interference patterns on the tear film lipid layer are observable.

30



16. The apparatus according to claim 15 wherein said illumination means further includes an arcuate emitter and wherein the surface of said emitter is substantially parallel to the surface of the eye.

5

17. The apparatus according to claim 15 wherein said means for observing the specularly reflected light comprises a hole defining an opening in the illumination means.

10 18. The apparatus according to claim 17 wherein said opening in the illumination means allows for observation of the specularly reflected light from behind said illumination means.

15 19. The apparatus according to claim 17 further including means for collecting and focusing the specularly reflected light and for generating an output signal representative thereof operatively associated with said opening.

20 20. The apparatus according to claim 19 further including means for recording the output signal representative of the specularly reflected light.

21. The apparatus according to claim 20 wherein said means for recording the output signal representative of the specularly reflected light records in real time.

25

22. The apparatus according to claim 19 wherein said means for collecting and focusing comprises a camera lens system.

30

23. The apparatus according to claim 20 wherein said means for recording is selected from the group of recording devices consisting of computer memory, video cassette recording devices, analog recording devices and digital recording devices.

5

24. The apparatus according to claim 15 wherein the specularly reflected light is observed when the patient's head is positioned on an observation platform.

10

25. The apparatus according to claim 15 wherein said arcuate emitter is constructed and arranged such that the light rays emitted therefrom strike the surface of the eye such that Snell's law is satisfied with respect to the acceptable angle of said means for collecting the specularly reflected light to produce an observable area of interference on the eye.

15

26. The apparatus according to claim 15 wherein said illumination means further includes a plurality of spaced apart light emitting diodes adapted to emit light in the visible region; and a diffuser means for diffusing the light emitted by the respective light emitting diodes positioned between said light emitting diodes and the surface of the eye and further, wherein the diffuser means is arcuate such that the light rays emitted from the lambertian emitter strike the surface of the eye such that Snell's law is satisfied with respect to the acceptance angle of said camera lens system to as to produce an observable area of interference on the eye.

25

30

27. The apparatus according to claim 25 further including means for collecting the specularly reflected light and for focusing the specularly reflected light generate an output signal representative thereof.

5

28. The apparatus according to claim 25 wherein said illumination means has a total radiated power of less than 1 W.

10

29. The apparatus according to claim 25 wherein the light rays that generate the visible viewing area of interference are essentially normal to the surface of the eye.

15 30. An apparatus for measuring the thickness of the lipid layer on the surface of a patient's eye after distribution of the lipid layer subsequent to blinking comprising:

an illuminator that directs light to the lipid layer of a patient's eye, the illuminator comprising a broad spectrum light source in the visible region and being a uniform illumination lambertian emitter such that the light source is specularly reflected from the lipid layer and  
20 undergoes constructive and destructive interference in the lipid layer; and further wherein the illumination means illuminates the patients face, but wherein only an area below the pupil satisfies Snell's law; and

an imaging device for observing the specularly reflected light such that the interference patters on the tear film lipid layer are observable in the area below the pupil with respect to the  
25 acceptance angle of the means for observing so as to produce an observable area of interference on the eye below the pupil.

30

31. The apparatus according to claim 30 further including means for collecting and focusing the specularly reflected light such that the interference patterns on the tear film lipid layer are observable.

5

32. The apparatus according to claim 30 wherein said illumination means illuminates an area of the patient's eye and wherein the area having viewable interference fringes is located below the pupil.

10

33. The apparatus according to claim 32 wherein the area having viewable interference fringes is an area of at least  $12.5\text{mm}^2$ .

15

34. The apparatus according to claim 30 wherein said illumination means has a total illumination intensity of less than that which would induce reflex tearing or cause a proprioceptive response to occur.

20

35. The apparatus according to claim 34 wherein said illumination means has a total illumination intensity of between about  $1\ \mu\text{W}/\text{mm}^2$  and  $15\ \mu\text{W}/\text{mm}^2$  at the surface of the illuminator.

25

36. The apparatus according to claim 32 wherein the specularly reflected light is observed when the patient's head is positioned on an observation platform.

30

37. The apparatus according to claim 30 further including means for recording the observable area of interference of the specularly reflected light.

5 38. The apparatus according to claim 37 wherein said means for recording the observable area of interference records in real time.

39. The apparatus according to claim 37 wherein said means for recording is selected from  
10 the group of recording devices consisting of computer memory, video cassette recording devices, analog recording devices and digital recording devices.

40. The apparatus according to claim 31 wherein said means for collecting and for focusing  
15 the specularly reflected light generate an output signal representative thereof.

41. The apparatus according to claim 30 wherein said illumination means comprises an array of light emitting diodes and a diffuser positioned between the respective diode array and  
20 the lipid layer of the tear film.

42. The apparatus according to claim 41 where said diffuser is arcuate such that the light rays emitted from the lambertian emitter strike the surface of the eye tangential thereto.  
25

43. An apparatus for measuring the thickness of the lipid layer on the surface of an eye after distribution of the lipid layer subsequent to blinking comprising:

an illuminator that directs light to the lipid layer of a patient's eye, the illuminator being  
30 a broad spectrum light source in the visible region and being a uniform illumination lambertian emitter such that the light source is specularly reflected from the lipid layer and undergoes

constructive and destructive interference in the lipid layer and wherein the light emitted from the illuminator travels directly to the lipid layer without reflection and strikes the lipid layer; and

5 an imaging device for collecting the specularly reflected light and for focusing the specularly reflected light such that the interference patterns on the tear film lipid layer are observable.

44. The apparatus according to claim 43 further including means for collecting and  
10 focusing the specularly reflected light such that the interference patterns on the tear film lipid layer are observable.

45. The apparatus according to claim 43 wherein the illumination means illuminates an area  
15 of the patient's eye and wherein the area having viewable interference fringes is located below the pupil.

46. The apparatus according to claim 43 wherein the area having viewable interference  
20 fringes is an area of at least 12.5 mm<sup>2</sup>.

47. The apparatus according to claim 43 wherein the illumination means has a total  
25 illumination intensity of less than that which would induce reflect tearing or cause a proprioceptive response to occur.

48. The apparatus according to claim 43 wherein the illumination means has a total  
30 illumination intensity of between about 1  $\mu\text{W}/\text{mm}^2$  and 15  $\mu\text{W}/\text{mm}^2$  at the surface of the illuminator.

49. The apparatus according to claim 43 wherein the illumination means has a total radiated power of less than about 1 W.

5

50. The apparatus according to claim 45 wherein the specularly reflected light is observed when the patient's head is positioned on an observation platform.

10 51. The apparatus according to claim 43 further including means for recording the observable area of interference of the specularly reflected light.

15 52. The apparatus according to claim 51 wherein the means for recording the observable area of interference records in real time.

20 53. The apparatus according to claim 51 wherein the means for recording is selected from the group of recording devices selected from the group consisting of computer, video cassette recording devices and digital recording devices.

25 54. The apparatus according to claim 44 wherein the means for collecting and for focusing the specularly reflected light generate an output signal representative thereof.

30 55. The apparatus according to claim 43 wherein the illumination means comprises an array of light emitting diodes and a diffuser positioned between the respective diode array and the lipid layer of the tear film.

56. The apparatus according to claim 55 where the diffuser is arcuate such that the light rays emitted from the lambertian emitter strike the surface of the eye tangential thereto.



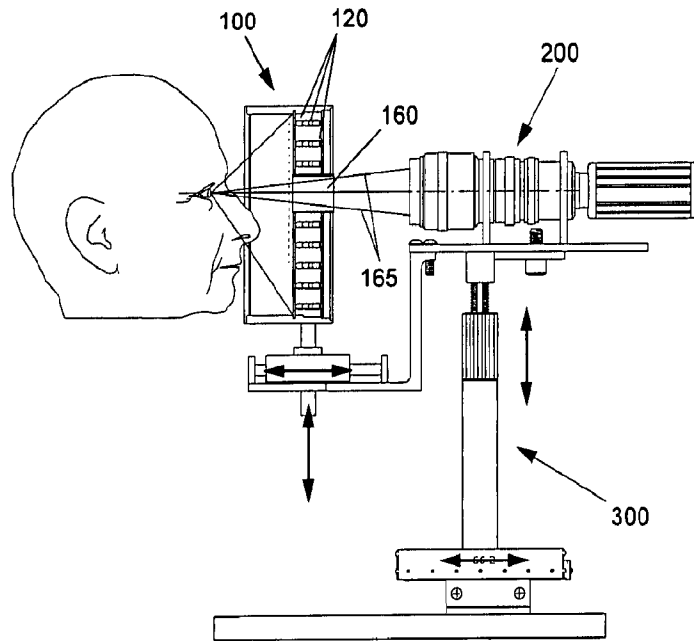

Fig. 1

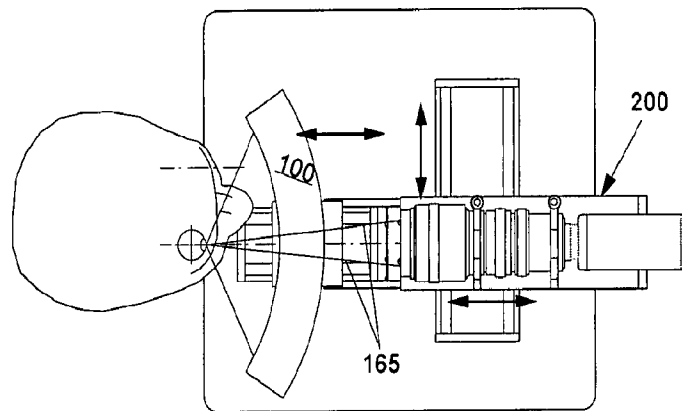

Fig. 2

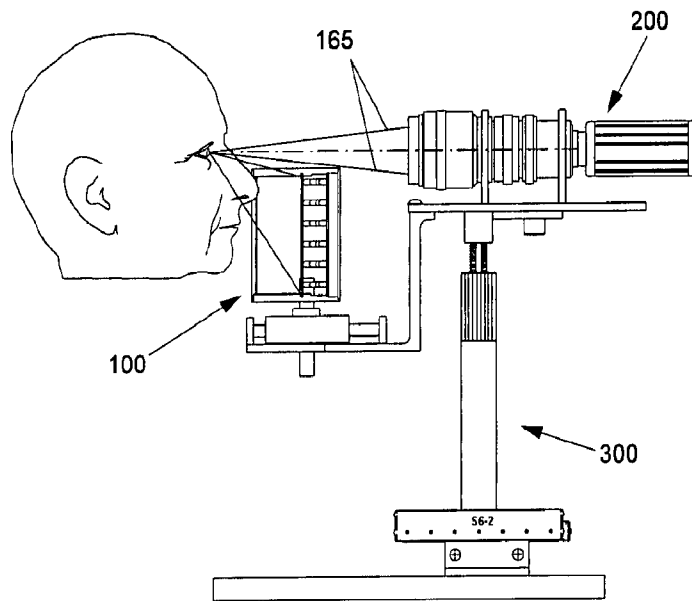

Fig. 3a

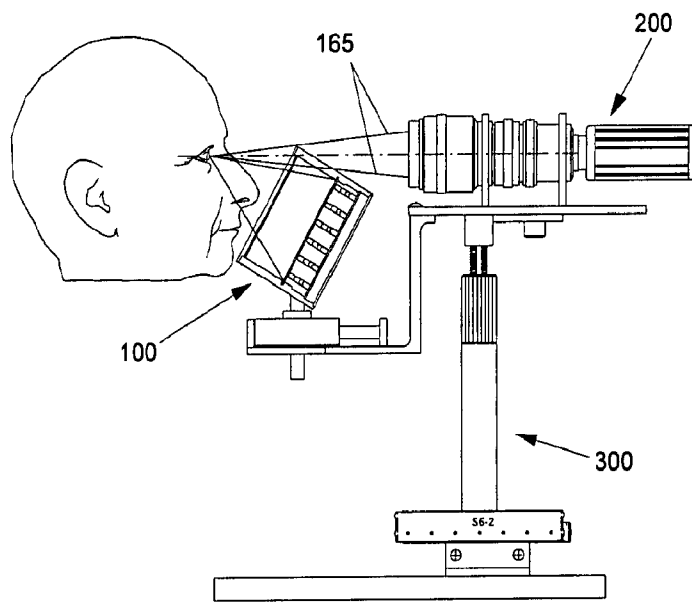

Fig. 3b

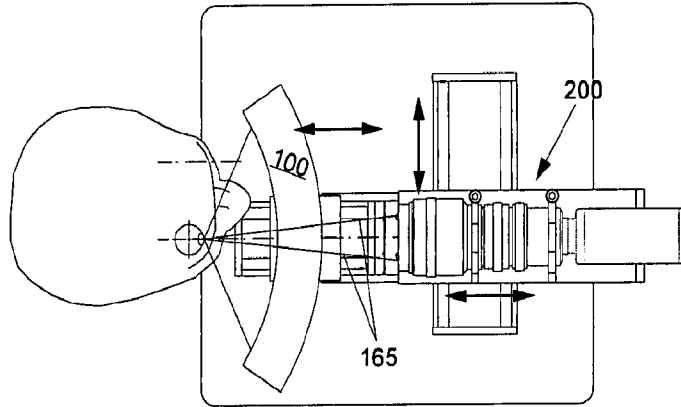

Fig. 4a

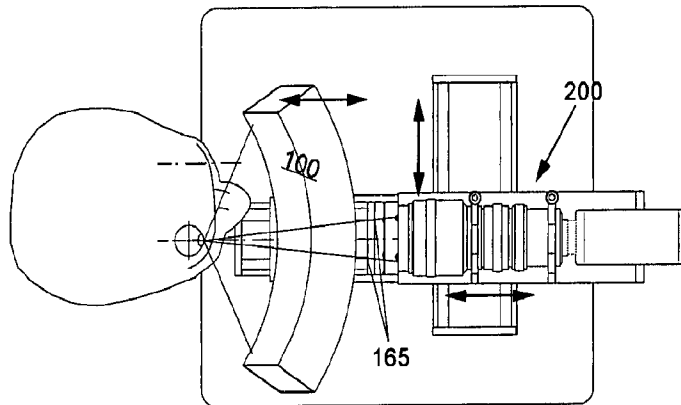

Fig. 4b

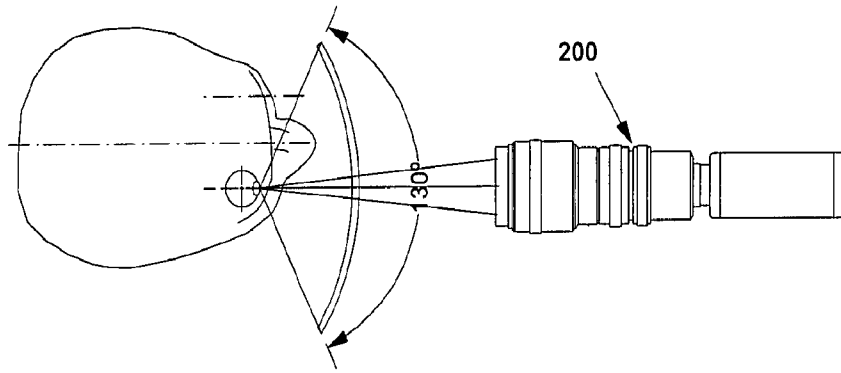

Fig. 5a

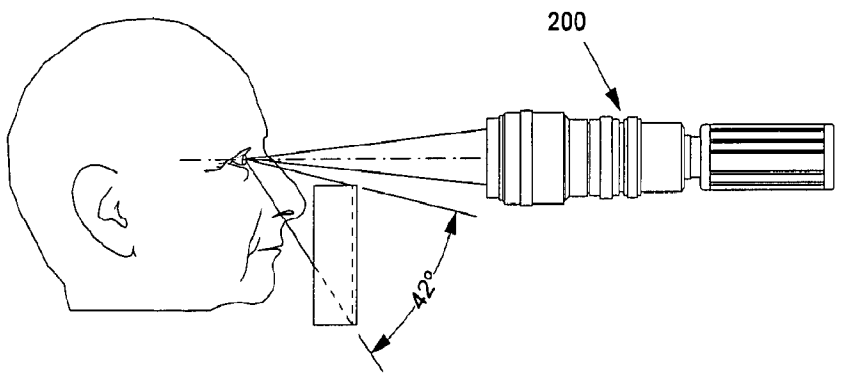

Fig. 5b

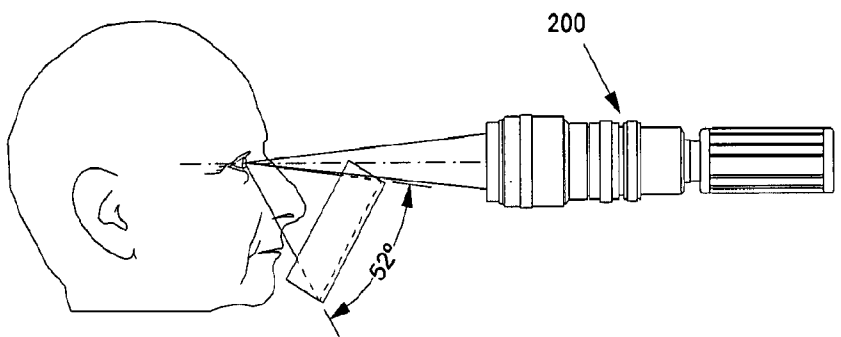

Fig. 5c

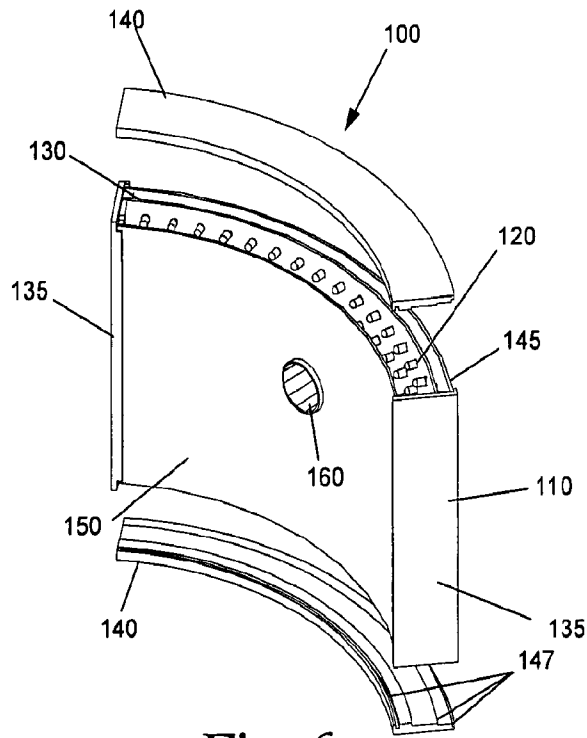

Fig. 6

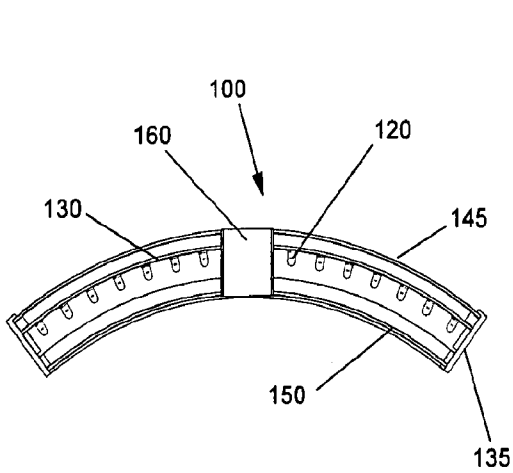

Fig. 7

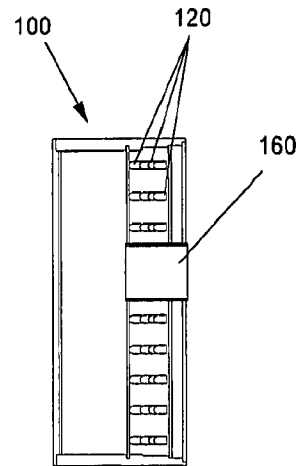

Fig. 8

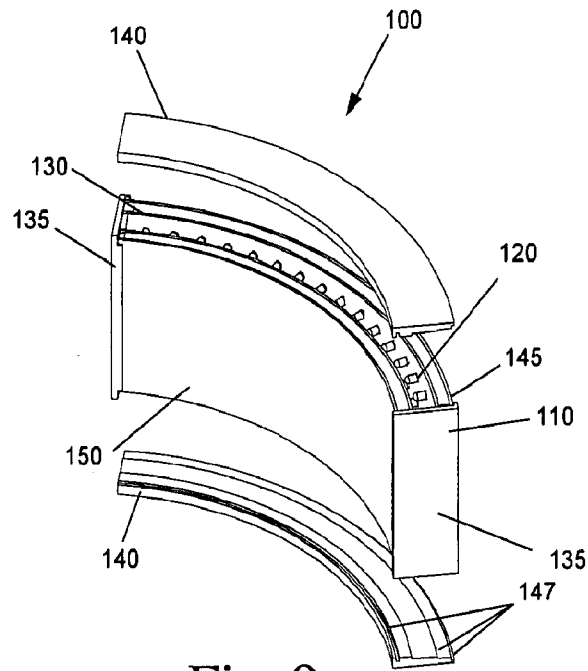

Fig. 9

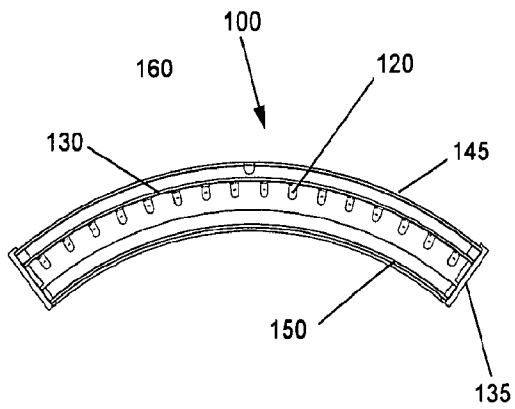

Fig. 10

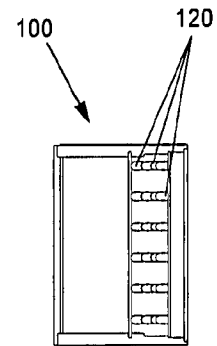

Fig. 11

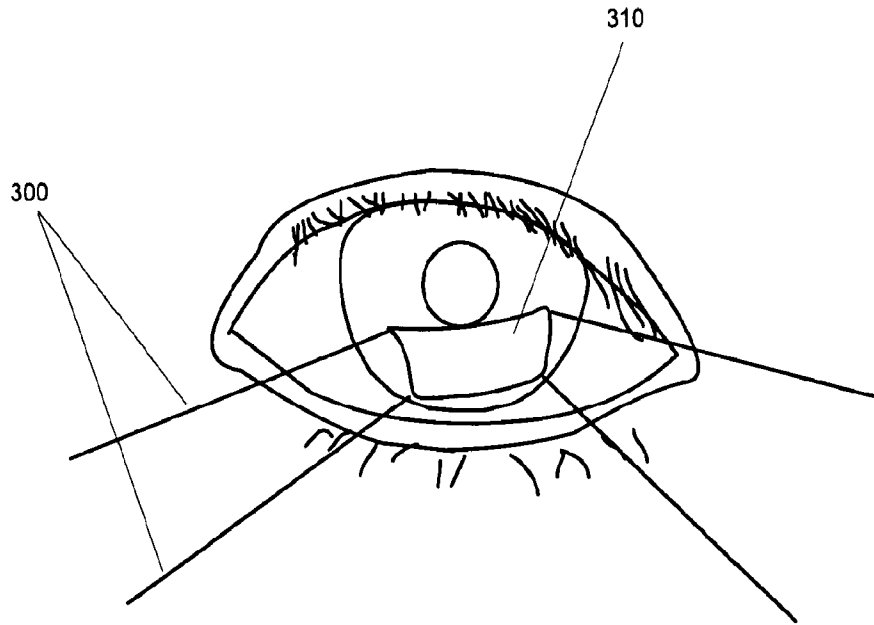

Fig. 12