

Feb. 16, 1932.

J. W. GALLOWAY

1,845,083

REMOVABLE GRAVITY LOCKING HANGER FOR HUMIDIFIER PANS

Filed April 18, 1930

Fig. 1.

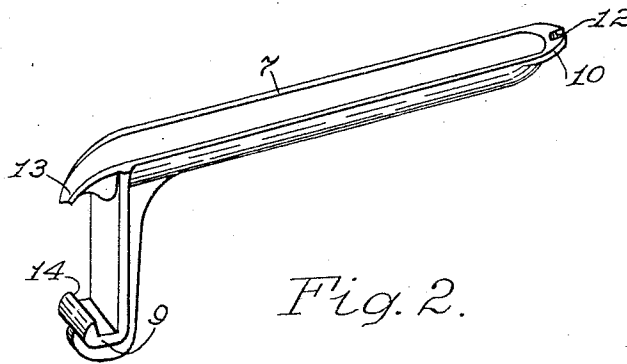
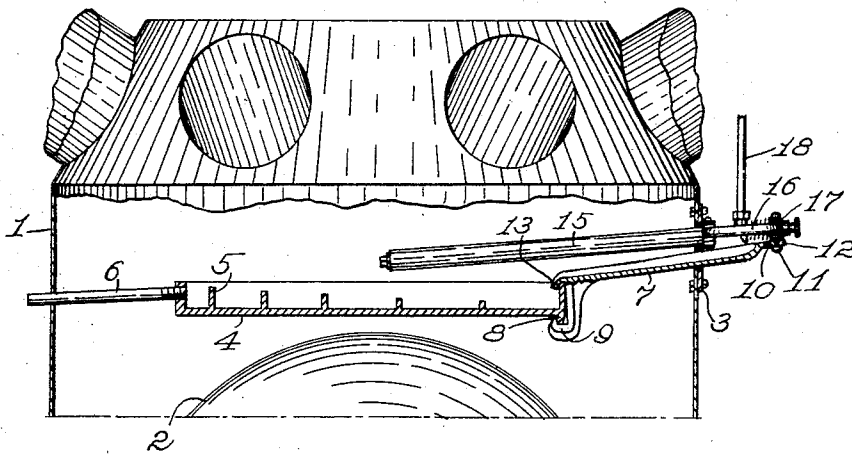

Fig. 2.

INVENTOR
James W. Galloway,
BY
G. Kennedy
ATTORNEY

UNITED STATES PATENT OFFICE

JAMES W. GALLOWAY, OF CEDAR FALLS, IOWA, ASSIGNOR TO AUTOMATIC HUMIDIFIER COMPANY, OF CEDAR FALLS, IOWA

REMOVABLE GRAVITY-LOCKING HANGER FOR HUMIDIFIER PANS

Application filed April 18, 1930. Serial No. 445,345.

My invention relates to improvements in humidifiers, and the object of my improvement is to supply for hot-air furnaces or like installations removable gravity-locking hangers for humidifier pans therein, the hangers including liquid delivery means and being adapted for ready assemblage with the pans releasably.

This object I have accomplished by the means which are hereinafter described and claimed, and which are illustrated in the accompanying drawings, in which Fig. 1 is a fragmental elevation of the upper part of a hot-air furnace with parts broken away, and showing my humidifier installed therein including the improvements above mentioned, the evaporating pan and the troughed hanger device being shown in medial vertical longitudinal section. Fig. 2 is an enlarged detail perspective view of the said troughed hanger device.

The furnace 1 is of a well-known type containing the crown 2 of the fire-box, the latter not shown. Medially transversely across the upper part of the furnace casing a little above the crown 2 is removably supported an elongated open top evaporating pan 4 having transverse partitions 5 of different heights, and having an overflow pipe 6 opening loosely into one end and traversing the casing of the furnace to deliver without it.

A face-plate 3 is fastened upon the outer opposite wall of the furnace casing which together with the face-plate is apertured to seat therethrough the upwardly troughed inclined hanger device 7 and above said device the outer end part of an inclined thermostatic regulator for automatically controlling the delivery of liquid, such as water, from a supply-pipe 18 without the furnace and into the outer end of the device 7, the thermostat barrel 15 overlying the trough part of the device 7 but projecting inwardly therebeyond over the pan 4.

The device or hanger body 7 at its inner termination is narrowed and curved downwardly to deliver into the abutting end of the pan 4 and rest upon the top of the end wall thereof. The hanger 7 also has an integral hanger hook 9 depending with a terminal

antichinal transverse detent 14 to fit and engage upon a transverse rib 8 on the bottom of the pan at that end, interlockingly. The assemblage is effected by first hooking the lip 13 over the pan end, then engaging the hook 9 upon the rib 8. The weight of the pan retains these parts interlocked.

The outer end of the hanger device 7 without the furnace is detachably secured to the outer part of said thermostat in the following way. The outer and flattened termination 10 of the troughed hanger 7 has a medial notch 12 to receive a screw 11 therethrough which also enters a threaded socket therefor in the cylindrical head 17 of the thermostat yoke 16 without the furnace. This supports the thermostat in the position shown. As the barrel 15 of the thermostat is positioned above the crown 2 passing currents of heated air act upon the thermostat in creating differential longitudinal expansion of elements thereof in controlling the delivery of the pipe 18. The thermostat is not described herein, being shown substantially in my United States Patent No. 1,637,693, dated August 2, 1927, but the improved thermostat is not specifically claimed herein, being shown and claimed in a co-pending application.

It will be understood that a liquid delivered from the pipe 18 into the trough 7 by way of the thermostat valve not shown, will flow downwardly into the pan 4 over the lip 13, and accumulate successively in the compartments of the pan by overflow. A supply of the liquid in the pan, of varying areas according to the governing control of the liquid delivery of the thermostat, will fill said compartments in turn, to provide increasing evaporating area thereof as required to maintain a standard of humidity in the furnace air delivered by the furnace ducts to the apartments of a building, and according to the varying heat within the furnace above the crown 2.

Having described my invention, what I claim as new, and desire to secure by Letters Patent, is:

1. In humidifying apparatus, the combination with a furnace casing, of an evaporating pan therein loosely connected thereto, and

a hanger-body connected detachably and loosely to and between both the casing and the pan to interlockingly engage the pan by relative sagging of the hanger-body and pan.

5 2. In humidifying apparatus, the combination with a furnace casing, of an evaporating pan therein loosely connected thereto, and a hanger-body connected detachably and loosely to and between both the casing and
10 pan to interlockingly engage the pan by relative sagging of the hanger-body and pan, the hanger-body having its upper part shaped as a trough adapted to deliver into the pan.

15 3. In humidifying apparatus, the combination with a furnace casing, of an evaporating pan therein loosely connected thereto, and having a transverse bottom rib at one end, and a hanger-body connected detachably to
20 and between said casing and pan, having upper and lower hooked parts to respectively loosely interlock with the upper edge of an end wall of the pan, and with the said bottom rib when the hanger-body sags relatively to
25 the pan.

4. In humidifying apparatus, the combination with a furnace casing, of an evaporating pan therein loosely connected thereto, having a transverse bottom rib depending at
30 one end, a hanger-body connected to the casing and having its upper part shaped with a longitudinal trough and a depending lip to deliver a liquid into said pan, and having a depending hook, said lip being adapted to
35 engage over an end wall of the pan and said hook to receive said rib when the hanger-body sags relative to the pan, and means for delivering a supply of liquid into the trough of the hanger-body.

40 In testimony whereof I affix my signature.
JAMES W. GALLOWAY.

45

50

55

60

35