

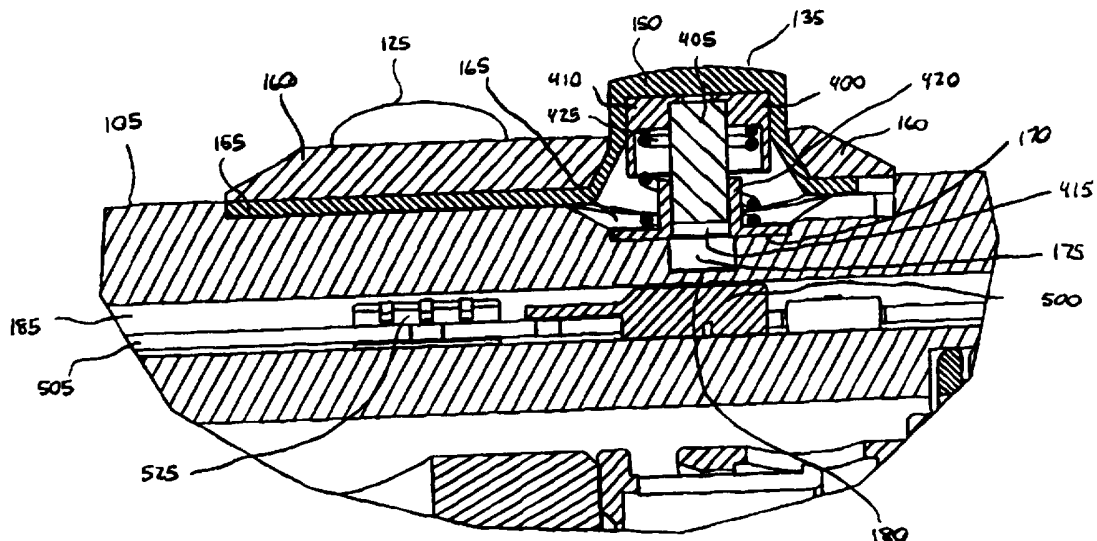

INTERNATIONAL APPLICATION PUBLISHED UNDER THE PATENT COOPERATION TREATY (PCT)

(51) International Patent Classification ⁶ : A61B 17/20, 17/32, 17/36	A1	(11) International Publication Number: WO 97/16123 (43) International Publication Date: 9 May 1997 (09.05.97)
<p>(21) International Application Number: PCT/US96/17625</p> <p>(22) International Filing Date: 31 October 1996 (31.10.96)</p> <p>(30) Priority Data: 60/007,117 31 October 1995 (31.10.95) US 08/630,125 10 April 1996 (10.04.96) US</p> <p>(71) Applicant: SMITH & NEPHEW, INC. [US/US]; 160 Dascomb Road, Andover, MA 01810 (US).</p> <p>(72) Inventor: SJOSTROM, Douglas, D.; 19 Cape Cod Avenue, Reading, MA 01867 (US).</p> <p>(74) Agent: DEVLIN, Peter, J.; Fish & Richardson P.C., 225 Franklin Street, Boston, MA 02110 (US).</p>	<p>(81) Designated States: AL, AM, AT, AU, AZ, BB, BG, BR, BY, CA, CH, CN, CU, CZ, DE, DK, EE, ES, FI, GB, GE, HU, IS, JP, KE, KG, KP, KR, KZ, LK, LR, LS, LT, LU, LV, MD, MG, MK, MN, MW, MX, NO, NZ, PL, PT, RO, RU, SD, SE, SG, SI, SK, TJ, TM, TR, TT, UA, UG, UZ, VN, ARIPO patent (KE, LS, MW, SD, SZ, UG), Eurasian patent (AM, AZ, BY, KG, KZ, MD, RU, TJ, TM), European patent (AT, BE, CH, DE, DK, ES, FI, FR, GB, GR, IE, IT, LU, MC, NL, PT, SE), OAPI patent (BF, BJ, CF, CG, CI, CM, GA, GN, ML, MR, NE, SN, TD, TG).</p> <p>Published <i>With international search report. Before the expiration of the time limit for amending the claims and to be republished in the event of the receipt of amendments.</i></p>	

(54) Title: MAGNETIC SWITCHING ELEMENT FOR CONTROLLING A SURGICAL DEVICE



(57) Abstract

An apparatus for controlling a surgical device includes a housing (105) and a magnetic switching element (400) mounted on the housing (105). The magnetic switching element (400) includes a magnet (405), a magnetic sensor (500) configured to produce a control signal for controlling the surgical device, and an actuator (410) mounted on the housing (105) for movement between a first position in which a magnetic field of the magnet is decoupled from the magnetic sensor (500) and a second position in which the magnetic field is coupled to the magnetic sensor (500) so as to change a value of the control signal produced by the magnetic sensor (500). The magnetic switching element (400) may also include magnetically soft material positioned so that movement of the actuator causes relative movement between the magnet and the magnetically soft material.

FOR THE PURPOSES OF INFORMATION ONLY

Codes used to identify States party to the PCT on the front pages of pamphlets publishing international applications under the PCT.

AM	Armenia	GB	United Kingdom	MW	Malawi
AT	Austria	GE	Georgia	MX	Mexico
AU	Australia	GN	Guinea	NE	Niger
BB	Barbados	GR	Greece	NL	Netherlands
BE	Belgium	HU	Hungary	NO	Norway
BF	Burkina Faso	IE	Ireland	NZ	New Zealand
BG	Bulgaria	IT	Italy	PL	Poland
BJ	Benin	JP	Japan	PT	Portugal
BR	Brazil	KE	Kenya	RO	Romania
BY	Belarus	KG	Kyrgyzstan	RU	Russian Federation
CA	Canada	KP	Democratic People's Republic of Korea	SD	Sudan
CF	Central African Republic	KR	Republic of Korea	SE	Sweden
CG	Congo	KZ	Kazakhstan	SG	Singapore
CH	Switzerland	LI	Liechtenstein	SI	Slovenia
CI	Côte d'Ivoire	LU	Luxembourg	SK	Slovakia
CM	Cameroon	LV	Latvia	SN	Senegal
CN	China	MC	Monaco	SZ	Swaziland
CS	Czechoslovakia	MD	Republic of Moldova	TD	Chad
CZ	Czech Republic	MG	Madagascar	TG	Togo
DE	Germany	ML	Mali	TJ	Tajikistan
DK	Denmark	MN	Mongolia	TT	Trinidad and Tobago
EE	Estonia	MR	Mauritania	UA	Ukraine
ES	Spain			UG	Uganda
FI	Finland			US	United States of America
FR	France			UZ	Uzbekistan
GA	Gabon			VN	Viet Nam

MAGNETIC SWITCHING ELEMENT FOR CONTROLLING
A SURGICAL DEVICE

This invention relates to handpieces for powered surgical
5 systems.

Surgical handpieces may operate a variety of surgical
instruments. Typically, a surgical handpiece includes a housing that
contains a motor. The motor rotates a drive shaft coupled to the
10 motor to transmit power to a surgical instrument through the drive
shaft.

A surgical handpiece may also include one or more switches
for activating and controlling the motor. For example, Rexroth, U.S.
15 Patent No. 5,217,478, describes a surgical handpiece that includes
four switches configured to turn the motor on and off, to change the
rotation direction of the motor between forward and reverse, and to
increase or decrease the rotation speed of the motor. Each switch
includes a pair of switch contacts positioned to be conductively
20 bridged upon depression of the switch.

However the strict requirement for sterilised instrumentation in
surgery necessitates that such handpieces are autoclaved but
typical sterilisation techniques preclude this, especially where
25 magnetic switches are involved. It is therefore an object of the
present invention to overcome this problem.

Accordingly, there is provided an apparatus for controlling a
surgical device, comprising:

30

a housing; and

2

a magnetic switching element mounted on the housing, the magnetic switch element including;

a magnet,

5 a magnetic sensor configured to produce a control signal for controlling the surgical device, and

an actuator mounted on the housing for movement between a first position in which a magnetic field of the magnet is decoupled from the magnetic sensor to a second position to couple the magnetic field to the magnetic sensor so as to change a value of the control signal produced by the magnetic sensor.

10

In one aspect, generally, the invention features an apparatus for controlling a surgical device. The apparatus includes a housing and one or more magnetic switching elements mounted on the housing. Each magnetic switching element includes a magnet, a magnetic sensor and an actuator. The magnetic sensor produces a control signal for controlling the surgical device. The actuator is mounted on the housing and moves from a first position in which a magnetic field of the magnet is decoupled from the magnetic sensor to a second position to couple the magnetic field to the magnetic sensor so as to change a value of the control signal produced by the magnetic sensor.

15

20

The invention provides a rugged, solid state design that requires no interaction between mechanical parts. Because no mechanical interaction is required, the magnet may be physically isolated from the magnetic sensor. This ensures that the switches do not provide a leakage path into the apparatus, which, in turn, means that the apparatus may be made fully autoclavable.

25

30

Embodiments of the invention may include one or more of the following features. The magnetic switching element may include magnetically soft material positioned so that movement of the actuator causes relative movement between the magnet and the magnetically soft material. The magnet may be coupled to the actuator so that movement of the actuator causes movement of the magnet. In addition, the magnetically soft material may be configured to substantially absorb the magnetic field produced by the magnet when the actuator is in the first position and not to substantially absorb the magnetic field produced by the magnet when the actuator is in the second position.

The magnet may be physically isolated from the magnetic sensor. For example, the magnet may be separated from the magnetic sensor by a wall of the housing.

The housing may be the housing of a surgical handpiece that contains a motor, and the control signal produced by the magnetic sensor may be used in controlling operation of the motor.

The magnetically soft material may include a switch bottom having a cylindrical opening, and the magnet may be positioned in the cylindrical opening when the actuator is in the first position, and extended beyond the cylindrical opening when the actuator is in the second position. The cylindrical opening may be positioned over a depression in an exterior surface of the housing that is configured to receive the magnet and has a closed bottom.

The magnetically soft material may also include a switch cover secured to the magnet. The switch cover may be biased

away from the cylindrical opening by a spring, and the switch bottom and the switch cover may be mechanically interlocked.

The magnetic sensor may be mounted on a substantially flat
5 circuit board that is positioned within the housing. Examples of magnetic sensors include Hall-effect devices and reed switches.

A distance between a position of the magnet when the actuator is in the first position and a position of the magnet when the
10 actuator is in the second position may be less than 0.1 inches (2.6mm) For example, the distance may be on the order of 0.06 inches (1.53mm).

In another aspect, generally, the invention features an
15 apparatus may for controlling a surgical device. The apparatus includes a housing and magnetic switching elements mounted on the housing. Each magnetic switching element may include a magnet positioned outside of the housing, a magnetic sensor positioned inside the housing and physically isolated from the
20 magnet by a wall of the housing, and an actuator mounted on the housing for movement from a first position in which a magnetic field of the magnet is decoupled from the magnetic sensor to a second position to couple the magnetic field to the magnetic sensor so as to change a value of a control signal produced by the magnetic sensor.

25 Embodiments of the invention may include one or more of the following features. Each of the magnetic switching elements may include magnetically soft material, and may be configured so that movement of the actuator causes relative movement between the magnet and the magnetically soft material. For example, the
30 magnet may be coupled to the actuator so that movement of the actuator causes movement of the magnet.

The magnetically soft material may include a switch cover secured to the magnet and a switch bottom having a cylindrical opening. The magnet may be positioned in the cylindrical opening when the actuator is in the first position and extended beyond the cylindrical opening when the actuator is in the second position. The magnetically soft material also may be configured to substantially absorb a magnetic field produced by the magnet when the actuator is in the first position and not to substantially absorb the magnetic field produced by the magnet when the actuator is in the second position.

In a further aspect of the present invention there is provided a surgical system comprising the apparatus as hereinbefore described and a surgical instrument.

In another aspect of the present invention, there is provided a surgical system as hereinbefore described in kit form.

Other features and advantages of the invention will become apparent from the following description of the preferred embodiments, including the drawings, and from the claims.

Brief Description of the Drawings

Fig. 1 is a perspective view of a surgical handpiece.

Fig. 2 is a block diagram of a surgical system including the
5 handpiece of Fig. 1.

Fig. 3A is a side cross sectional view of a surgical handpiece.

Fig. 3B is an enlarged portion of the cross sectional view of
Fig. 3A.

Fig. 4A is an exploded top perspective view of a magnetic
10 switching element of the handpiece of Fig. 1.

Fig. 4B is a bottom perspective view of the magnetic
switching element of Fig. 4A.

Fig. 4C is a cross sectional view of an alternative magnetic
switching element.

15 Fig. 4D is a cross sectional view of the magnetic switching
element of Fig. 4A in a depressed position.

Fig. 5A is a top view of a circuit board of the handpiece of Fig.
1.

Fig. 5B is an end view of the circuit board of Fig. 5A.

20 Fig. 6A is a perspective view of a surgical instrument
configured for attachment to the handpiece of Fig. 1.

Fig. 6B is a perspective view of a hub and drive shaft of the
surgical instrument of Fig. 6A.

Fig. 6C is a side view of the hub and drive shaft of Fig. 6B.

25 Fig. 7A is a cross sectional side view of an interface between
the handpiece of Fig. 1 and the hub and drive shaft of Figs. 6A-6C,
taken at the longitudinal axis of the handpiece.

Fig. 7B is a cross sectional side view of the interface of Fig.
7A, offset from the longitudinal axis of the handpiece.

30 Figs. 8A-8D are functional diagrams of the latching
mechanisms of the interface of Fig. 7A.

Fig. 9A is a side view of an alternative latching mechanism.

Fig. 9B is a top view of an end of a handpiece configured for interaction with the latching mechanism of Fig. 9A.

5 Fig. 9C is a sectional view of the handpiece end of Fig. 9B taken along section 9C-9C.

Fig. 9D-9H are side and top views of other alternative latching mechanisms.

10 Figs. 10A-10C are perspective and plan views of an alternative latching mechanism.

Figs. 11A and 11B are perspective views of an alternative latching mechanism.

Fig. 12 is a side view of an adapter including the latching mechanism of Figs. 6A-6C.

15

Description of the Preferred Embodiments

With reference to Figs. 1 and 2, a motorized, reusable surgical handpiece 100 (Fig. 1) is configured to operate a variety of disposable (or reusable) surgical instruments. The handpiece has a generally cylindrical shape, with a teardrop-shaped cross section, and includes a housing 105 made from a non-magnetic material such as aluminum. At its distal end, the handpiece includes a cylindrical bore 110 for attachment of a surgical instrument. Within the bore 110 is a drive shaft 115 that is coupled to a motor 120 positioned within the handpiece 100. The handpiece includes pushbutton switches 125, 130 and 135 that produce signals for use in controlling the motor 120. The handpiece 100, including the pushbutton switches 125, 130 and 135, is fully autoclavable.

20

25

The handpiece 100 is employed in a surgical system 200 that includes the handpiece, a console 205, a surgical instrument 300 (or a set of surgical instruments), and a foot control assembly 210. A processor 215 positioned within the console 205 controls the
5 operating speed and direction of the motor 120 of the handpiece 100. This, in turn, controls the operating speed and direction of the surgical instrument 300. For example, when the surgical instrument 300 includes an active portion 305 (such as a cutting blade or an abrading burr) that rotates about the longitudinal axis 140 of the
10 handpiece 100, the processor 215 controls the direction and speed at which the active portion 305 rotates.

The processor 215 controls the motor 120 in response to signals from the pushbutton switches 125, 130 and 135, the console
15 205, and the foot control assembly 210. In addition, as discussed below, the handpiece 100 provides the processor 215 with information indicative of the instrument type of the surgical instrument positioned in the handpiece. The handpiece 100 is connected to the console 205 by a cable 145 that is attached to the
20 proximal end of the handpiece by a threaded connector 146.

In addition to the processor 215, the console 205 includes a power switch 220 for activating or deactivating the system, and buttons to increase (225) or decrease (230) the speed of the
25 handpiece motor 120. To display information, the console includes a sixteen character fluorescent display 235 for diagnostic messages, digital displays of the motor speed (240) and the permissible range for the motor speed (245, 250), and a bar graph display 255 of the motor speed within the permissible range. The foot control
30 assembly 210 is attached to the console 205 through a cable 260 and permits an operator to select between forward, reverse and

oscillate modes of operation for the motor 120 of the handpiece 100. Alternatively, the foot control assembly can be used to control the position of an operative portion of the surgical instrument.

5 Referring also to Figs. 3A and 3B, the three pushbutton switches 125, 130 and 135 are attached to the exterior of the housing 105 and are physically isolated from the electronic circuitry associated with the switches by a wall of the housing. This isolation ensures that the switches do not provide a leakage path to the
10 electronics and thereby ensures that the handpiece 100 and the switches 125, 130 and 135 are autoclavable. In addition, no separate seal is required to isolate the switches from the circuitry. The switches, which are round and identically sized, are located near the distal end of the handpiece 100 and are arranged in a
15 triangular configuration. Fewer or more switches (e.g., two or four switches) could be used and the switches could be arranged in a different configuration.

As already discussed, the switches 125, 130 and 135 provide
20 signals to the processor 215 through cable 145, and the processor 215 uses the control signals to control the motor 120 in the handpiece 100. The functions of the switches need not be explicitly defined and may be configured by programming the processor 215. For example, switch 125 may cause the processor 215 to control the
25 motor 120 to cycle through forward, reverse and oscillate modes of operation, while switch 130 causes the processor to cycle the motor through a circular range of speeds and switch 135 causes the processor to activate or deactivate the motor.

30 In another configuration, the switches respectively cause the processor to control the motor to operate in a forward mode (switch

125), a reverse mode (switch 130), or an oscillate mode (switch
135). In this alternative configuration, pressing any one of the
switches activates the motor and causes the motor to operate in the
corresponding mode. Thereafter, pressing any switch deactivates
5 the motor. To switch, for example, from the forward operating mode
to the reverse operating mode, an operator would press any one of
the three switches to deactivate the motor and would thereafter
press switch 130 to reactivate the motor in the reverse mode.

10 Each of switches 125, 130 and 135 also may have multiple
functions. For example, quickly pressing a switch may cause the
motor to switch between forward and reverse modes of operation
while continually pressing the switch causes the motor to operate in
an oscillation mode. Similarly, quickly pressing a switch may
15 activate the motor while continually pressing the switch gradually
increases the speed of the motor or controls the position of an
operative portion of the surgical instrument as discussed above.

Referring also to Figs. 4A and 4B, each of switches 125, 130
20 and 135 comprises a magnetic switching element 400 that includes
a permanent magnet 405 surrounded by magnetically soft material.
The magnetically soft material absorbs the magnetic field produced
by magnet 405 to shunt the magnet to prevent the magnetic field
from actuating switching circuitry in the handpiece until the switch is
25 depressed by the user, and do so without becoming magnetized
over time.

Each of switches 125, 130 and 135 includes a rubber boot
150 positioned over the magnetic switching element 400. The
30 rubber boots 150 are formed in a sheet of silicone rubber 155 that is
secured to the housing 105 of handpiece 100 by a metal cover 160.

The permanent magnet 405 of each magnetic switching element 400 is secured to a switch cover 410 and positioned within a cylindrical opening 415 of a switch bottom 420. The switch cover 410 serves as an actuator for the switch. A spring 425 biases the switch cover 410 away from the switch bottom 420, and rubber boot 150 maintains the switching element 400 as a single unit. In an alternative arrangement, as illustrated in Fig. 4C, switch cover 410 and switch bottom 420 are mechanically interlocked so that rubber boot 150 serves no role in maintaining switching element 400 as a single unit. The switch cover 410, switch bottom 420 and spring 425 are made from a magnetically soft material such as Carpenter 430F solenoid quality magnetically soft stainless steel. Other magnetically soft materials such as magnetically soft iron could also be used, but magnetically soft stainless steel is employed for its corrosion resistance.

The magnetic switching elements 400 are positioned and configured to interact with corresponding Hall-effect sensors that are physically isolated from the switching elements. Each magnetic switching element 400 is positioned in a recessed portion 165 of the housing 105. In particular, each magnetic switching element 400 is positioned on a recessed shelf 170 that is sized to accommodate the switch bottom 420 and overlies a depression 175 in the housing. The depression 175 has a diameter that is slightly larger than the diameter of the cylindrical opening 415 of the switch bottom 420 and has a closed bottom. For example, at the bottom of the depression 175 corresponding to switch 135 is a wall 180 of the housing 105 that physically isolates the magnetic switching element 400 from a Hall-effect sensor 500 that corresponds to the switch 135. This physical isolation provides a barrier against any potential leakage path through the switch 135. However, because the housing 105 is

made from aluminum, a non-magnetic material, the magnetic switching element 400 is not magnetically isolated from the Hall-effect sensor 500.

5 When switch 135 is not depressed, the permanent magnet 405 is positioned within a volume defined by the switch cover 410 and switch bottom 420. As noted above, these elements absorb the magnetic field produced by the permanent magnet 405. When the permanent magnet 405 is positioned within the volume defined by
10 the switch cover 410 and the switch bottom 420, these elements, along with the spring 425, complete a magnetic circuit that prevents a significant portion (if not all) of the magnetic field produced by the permanent magnet 405 from reaching the Hall-effect sensor 500. That is, the magnetic field is decoupled from the Hall-effect sensor
15 500.

As illustrated in Fig. 4D, depressing switch 135 causes a portion of the magnet 405 to extend beyond switch bottom 420 into the depression 175. As noted above, the housing 105 of the
20 handpiece 100 is made from aluminum, a material that does not absorb the magnetic field and does not shunt the magnet 405. Thus, depressing switch 135 causes a portion of the magnet 405 to move from a shunted position to a relatively unshunted position. When the magnet 405 is in the unshunted position, the magnetic
25 field produced by magnet 405 is coupled to and sensed by the Hall-effect sensor 500. Similar results could be obtained if the housing 105 were made from another non-magnetic material such as plastic or austenitic non-magnetic stainless steel.

30 The Hall-effect sensor 500 responds to the magnetic field by sending a signal to console 205 along a multiplexed bus in cable

110. The Hall-effect sensor 500 is a model A3054SU Hall-effect sensor supplied by Allegro Microsystems, Inc. of Worcester, Massachusetts. The sensor includes a high-resolution bipolar Hall-effect switching circuit that drives high-density CMOS logic stages.

5 The logic stages decode serial address pulses sent by processor 215 on the multiplexed bus and produce a response when an appropriate address is received. This response is indicative of whether the Hall-effect sensor has detected a magnetic field. Processor 215 responds to the signal from the Hall-effect sensor

10 500 by controlling the motor 120 in accordance with the function of the switch 135. The Allegro sensor also includes an input that permits connection of a mechanical switch. Thus, if desired, a mechanical switch could be coupled to the magnetic switching element 400 for redundancy or as a failsafe measure, or could

15 replace the magnetic switching element 400. However, such an arrangement would likely require the formation of a physical passage through the housing 105. Other magnetic sensors such as, for example, Hall-effect sensors by other manufacturers or reed switches, could also be used.

20

Switch 135 has a stroke length on the order of 0.06 inches (i.e., the magnet 405 is 0.06 closer to the Hall-effect sensor 500 when switch 135 is depressed than it is when switch 135 is not depressed). Thus, the physical distance between the magnet 405

25 and the Hall-effect sensor 500 is of little significance to whether the Hall-effect sensor 500 detects the magnetic field produced by the magnet 405. Rather, the significant factor is whether magnet 405 is extended beyond switch bottom 420 so that the magnet 405 is no longer shunted and the magnetic field is permitted to reach the Hall-

30 effect sensor 500. Magnet 405 is shunted during the first third of the

stroke of switch 135, and is extended beyond switch bottom 420 during the second two thirds of the stroke.

Referring also to Figs. 5A and 5B, Hall-effect sensor 500 is
5 mounted on a circuit board 505 that is positioned in a channel 185 in the housing of the handpiece 100. The circuit board 505 is flat, 15 mils thick, and only slightly flexible. Hall-effect sensor 500 is positioned within a cutout in the circuit board 505, and is connected to the circuit board by leads 510 that are soldered to a pair of circuit
10 paths 515 that define the bus which electrically connects the Hall-effect sensor 500 to the console 205. Wires 520 connected to the circuit paths 515 transmit signals to and from the console 205.

Hall-effect sensors 525 and 530, which correspond,
15 respectively, to switches 125 and 130, are positioned in cutouts in the side of circuit board 505 and located beneath switches 125 and 130. Sensors 525, 530 are angled relative to the circuit board 505 to accommodate curvature of the handpiece 100, and are connected by leads 510 that are soldered to the circuit paths 515.

20
An additional pair of Hall-effect sensors 535 are positioned adjacent to the bore 110 and respond to magnets in the surgical instruments to identify the type of instrument installed in the handpiece 100. Sensors 535 are angled and connected in the same
25 way as are sensors 525 and 530. The Hall-effect sensors 535 detect whether magnets are present in each of two chambers within a surgical instrument and provide this information to the processor 215. Using this information, the processor 215 identifies an
30 instrument type to which the instrument belongs and uses the instrument type to carry out subsequent processing. For example, the processor 215 may use the instrument type to set the

permissible range of operating speeds for the instrument. Through use of the two Hall-effect sensors 535, up to four different instrument types (i.e., no magnets, a magnet in one of the chambers, a magnet in the other chamber, magnets in both chambers) may be encoded.

5 Additional Hall-effect sensors 535 and corresponding magnet chambers could be employed to encode larger numbers of instrument types (e.g., four Hall-effect sensors 535 could encode 16 instrument types). Techniques for encoding instrument types are described in U.S. Patents Nos. 4,705,038 and Re. 34,556, which are

10 entitled "Surgical System for Powered Instrument" and are incorporated by reference.

The circuit board 505 also includes an extension 540 that aids in insertion of the circuit board 505 into the channel 185.

15

Referring to Figs. 6A-6C, a disposable surgical instrument 300 for use with the surgical handpiece discussed above includes a resilient latching mechanism 310 and is configured for insertion into the handpiece 100 without manipulating the latching mechanism

20 310 or any latching mechanism on the handpiece. The latching mechanism 310 includes a cantilevered resilient arm 315 that is radially spaced from an exterior surface of a hub 320 of the instrument 300. A user-manipulable release button 325 is mounted on the cantilevered arm with ramped latches 330 positioned on

25 either side of the release button 325. Each of the latches 330 includes a ramped leading edge 335 and a back-cut trailing edge 340.

The hub 320 is formed from a single piece of injection molded plastic to which is secured a ring structure 342 that carries

30 cantilevered arm 315 so that arm 315 extends proximally and

adjacent to the exterior surface of hub 320. The ring structure 342 is joined to the distal end of the hub 320 by a snap fit. In alternative arrangements, the ring structure could be integral to the hub or secured to the proximal end of the hub. When the ring structure is secured to the proximal end of the hub, the orientation of the latches 330 relative to the resilient arm 315 are reversed so that the latches 330 continue to have ramped leading edges and back-cut trailing edges.

10 Referring also to Figs. 1, 3A, 7A and 7B, the bore 110 of the handpiece 100 is configured to engage with the latching mechanism 310 of the surgical instrument 300. For this purpose, the exterior surface of the distal end of the handpiece includes a recessed portion 600 having a slot 605 for insertion of the release button 325 of the surgical instrument when the hub 320 is inserted into the bore 15 110. The recessed portion is provided for ease of operation and helps to eliminate any chance that a surgical instrument positioned in the handpiece will be inadvertently released.

20 An annular flange 610 within the bore 110 engages the ramped latches 330 of the surgical instrument to axially secure the instrument to the handpiece 100. The annular flange 610 has a ramp-shaped leading edge 615 and a back-cut trailing edge 620. With the exception of the region defined by the slot 605, the annular flange extends around the entire interior diameter of the bore 110. 25 However, a partial flange could also be used. Indeed, the only functional limitation on the flange is that it engage the latching mechanism 310. As such, the annular flange 610 need not include a ramp-shaped leading edge or a back-cut trailing edge and could 30 have, for example, a square or rectangular cross section. In

addition, should excessive wear be a concern, the annular flange 108 could be formed with a steel insert.

5 A guide slot 625 interacts with a tab 345 that protrudes from surgical instrument hub 320 to radially secure the surgical instrument to the handpiece and prevent rotation of the surgical instrument in response to torque applied by the motor 120. As illustrated, the guide slot 625 only extends through a portion of the radial dimension of the handpiece and is configured to accept an
10 equally sized tab. The dimensions of the guide slot and the tab may be varied to prevent the use of certain surgical instruments in conjunction with certain handpieces. For example, an alternative handpiece could include a guide slot extending completely through the radial dimension. Surgical instruments configured for use only
15 with the alternative handpiece could include a tab that is longer in the radial direction than is the guide slot of the present handpiece so that those instruments would not be attachable to the present handpiece. This arrangement would still permit surgical instruments that are attachable to the present handpiece to be attached to the
20 alternative handpiece.

The tab 345 is located on the hub 320 opposite the latching mechanism 310 and distally of the release button 325. Accordingly, radial alignment of the tab 345 with the guide slot 625 as the
25 surgical instrument 300 is inserted into the handpiece 100 is ensured by alignment of the release button 325 in the slot 605.

With reference also to Figs. 8A-8D, the latching mechanism 310 of the surgical instrument 300 permits an operator to fixedly
30 engage the surgical instrument 300 with the handpiece 100 by merely inserting the hub 320 into the bore 110 of the handpiece 100.

The hub is inserted with the release button 325 aligned with the slot 605, which has a flared opening to ease alignment (Fig. 1). As the hub is inserted, the ramped leading edges 335 of the ramped latches 330 engage with the ramped leading edge 615 of the annular flange 610 (Fig. 8A). Additional insertion force causes the resilient arm 315 to bend as the ramped leading edges move past each other (Fig. 8B). Eventually, the trailing edges 340 of the ramped latches 330 pass the trailing edge 620 of the annular flange 610 (Fig. 8C). At this point, the resilient arm 315 returns to its normal, unbent orientation and the ramped latches 330 snap into place with their trailing edges against the trailing edge of the annular flange 610 (Fig. 8D). Because the trailing edges of both the annular flange 610 and the ramped latches 330 are back-cut, the hub 320 moves slightly toward the distal end of the handpiece 100 when the latches 330 snap into place.

Referring to Figs. 6A-6C, the surgical instrument 300 includes a drive shaft 350 that is inserted into the hub 320. The drive shaft 350 includes an extension 355 that engages with the spring-loaded, sealed drive shaft 115 of the handpiece 100. When the surgical instrument 300 is positioned in the handpiece 100, rotation of the drive shaft 115 causes the drive shaft 350 to rotate. Techniques for sealing the drive shaft 115 are described in U.S. Patent No. 5,133,729, which is entitled "Motor-Driven Hand-Piece for a Surgical Tool" and is incorporated by reference.

25

To ease alignment of extension 355 with drive shaft 115, extension 355 includes a drill tip configuration 357 with sloped, canted edges at its proximal end. If extension 355 is not aligned with drive shaft 115 as the surgical instrument is inserted into the handpiece, the drill tip configuration 357 engages with the drive shaft 115 and causes the extension 355 (along with the drive shaft

30

350) to rotate until the extension and the drive shaft are properly aligned.

The spring loading of drive shaft 115 effects a distally
5 directed force against the hub 320 through the drive shaft 350. This force serves to secure the surgical instrument 300 in the bore 110. Additional securing force is provided by a compliant rubber seal 365 that is secured to the hub 320 by a pair of tabs 367 and provides a fluid-tight seal with the walls of the bore 110.

10

When the ramped latches 330 are engaged with the trailing edge of the annular flange 610, the spring 190 of the drive shaft 115 is compressed and exerts a force against the ramped latches 330 through the drive shaft 350 and the hub 320. This force secures the
15 ramped latches 330 against the annular flange 610. Since the trailing edges of both the annular flange 610 and the ramped latches 330 are back-cut, the force exerted by the spring 190 must be overcome before the latches 300 can be disengaged from the flange 610.

20

In addition to providing ease of engagement between the handpiece 100 and the surgical instrument 300, the latching mechanism 310 permits the operator to release the instrument 300 from the handpiece 100 by simply pressing release button 325, and
25 does not require manipulation of the handpiece 100 or further manipulation of the surgical instrument 300. When the release button 325 is pressed, the trailing edges of sloped ramps 330 are moved along the trailing edge of the annular flange 610 until the trailing edges no longer contact the annular flange (Fig. 8C). At that
30 point, the spring 190 of the drive shaft 115 forces the surgical

instrument 300 away from the proximal end of the handpiece 100 until the spring 190 is no longer compressed.

5 The hub includes a pair of radially extending chambers 360 (Fig. 7B) in which may be embedded magnets 362. As discussed above, the magnets 365 interact with Hall-effect devices 535 to identify the instrument type of surgical instrument 300. Each chamber 360 is covered by a plastic cap 364.

10 Surgical instruments may be configured to perform a variety of surgical operations. Numerous examples of surgical instruments are provided in, for example, U.S. Patent No. 4,203,444, entitled "Surgical Instrument Suited for Closed Surgery"; U.S. Patent No. 4,274,414, entitled "Meniscal Cutter (Surgical Instrument)"; U.S. Patent No. 4,522,206, entitled "Surgical Instrument"; U.S. Patent No. 4,662,371, entitled "Surgical Instrument"; U.S. Patent No. 4,834,729, entitled "Arthroscopic Surgical Instrument"; U.S. Patent No. 4,842,578, entitled "Surgical Instrument for Arthroscopic Arthroplasty"; U.S. Patent No. 4,983,179, entitled "Arthroscopic Surgical Instrument"; U.S. Patent No. 5,152,744, entitled "Surgical Instrument"; U.S. Patent No. 5,320,635, entitled "Surgical Device"; and U.S. Patent No. 5,322,505, entitled "Surgical Instrument", all of which are incorporated by reference. Additional instruments are described in U.S. Application Serial No. 08/319,057, entitled "Surgical Instrument", which was filed on September 23, 1994; U.S. Application Serial No. 08/425,719, entitled "Curved Surgical Instrument with Segmented Inner Member", which was filed on April 20, 1995; U.S. Application Serial No. 08/388,992, entitled "Surgical Instrument", which was filed on February 15, 1995; and U.S. Application Serial No. 08/200,662, entitled "Surgical Instrument",

which was filed on February 23, 1994, all of which are incorporated by reference.

In the illustrated embodiment, the surgical instrument 300 is a cutting instrument that includes a fixed hub 320 to which is attached a hollow outer tube 370, and a rotatable drive shaft 350 to which is attached a hollow inner tube 375. Openings in the distal ends of the tubes 370 and 375 have sharpened edges and perform a cutting action when the inner tube 375 is rotated within the outer tube 370. While hub 320 and drive shaft 350 are made from injection-molded plastic, tubes 370 and 375 are made from stainless steel to render the instrument readily disposable. Other materials could be used if it was desirable to make the instrument reusable.

Referring also to Figs. 3A, 3B, 7A and 7B, drive shaft 350 includes an opening 380 that permits material drawn through inner tube 375 to pass into an aspiration channel 630 of the handpiece 100. The handpiece 100 also includes a handle 635 that controls a valve 640 and thereby controls flow through the aspiration channel 630. The handle 635 is positioned on the bottom of the handpiece near the distal end of the handpiece, and rotates about an axis 645 that is perpendicular to a longitudinal axis 140 of the handpiece. This orientation permits one-handed, finger control of flow through the aspiration channel 630 by a person holding the handpiece 100. The aspiration channel 630 ends at an aspiration spigot 650 at the proximal end of the handpiece. During use, the spigot 650 is connected to a source of suction (not shown).

Three knurled bands 655 define arcs about the circumference of the handpiece 100. These bands provide ease of gripping, and are formed by scoring the outer surface of the handpiece.

Other embodiments are also contemplated. For example, as illustrated in Fig. 9A, an alternative latching mechanism 900 includes a release button 905 that is axially spaced from a ramped latch 910.

5 Due to the axial displacement, relatively more force must be incident on release button 905 to move ramped latch 910 than must be incident on release button 325 to move ramped latch 330 radially away from flange 610. To ease assertion of the additional force, release button 905 typically has a larger surface area than does

10 release button 325. The axial displacement of the release button 905 relative to the ramped latch 910 permits the flange 610 to be moved proximally relative to the slot 605, which can be accomplished by shortening the slot, moving the flange, or a combination of the two. Movement of the flange relative to the slot

15 eliminates the break in the flange due to the slot, while movement of the latch relative to the release button eliminates the break in the latch due to the release button. This permits the latch and flange to engage each other along continuous surfaces.

20 As shown in Figs. 9B and 9C, a handpiece 915 for use with the latching mechanism 900 is identical to the handpiece 100 described above with the exception that the flange 920 of the handpiece 915 is positioned further from the distal end of the handpiece than is the flange 610 of the handpiece 100. In this

25 configuration, the flange 920 is positioned proximally of the slot 605 within the bore 110 and no longer intersects the slot 605. Accordingly, the flange 920 is uninterrupted and forms a continuous ring around the interior of the bore 110. Similar results may be obtained by maintaining the position of the flange within the bore

30 and shortening the slot 605.

The latching mechanism 310 may also be varied in other ways. For example, Fig. 9D illustrates an alternative latching mechanism 925 that includes a release button 930 and a latch 935 having a square cross section. Figs. 9E and 9F illustrate a latching mechanism 940 that includes a release button 945 and a ramped latch 950. In addition to having a ramped leading surface 955, the latch 950 includes a leading edge 960 that tapers to a point 965 in the longitudinal direction. Similarly, a latch 970 illustrated in Figs. 9G and 9H includes a release button 975 and a latch 980 that includes a ramped leading surface 985 and a curved leading edge 990.

Referring to Figs. 10A-10C, another alternative latching mechanism includes a tab 1000 and a tab 1005. Tab 1000 is mounted on a hub 1010 of a surgical instrument 1015. Tab 1005 is mounted on the proximal side of a spring-loaded plate 1020 that is positioned at the distal end of the hub 1010. Tabs 1000 and 1005 are positioned to define an arc on the order of 170° around the circumference of the hub 1010. At installation, the hub 1010 is inserted into the bore 110 of the handpiece, with the tab 1000 aligned with the slot 605. The hub is inserted until tab 1000 passes through the gap in the flange 610 that is formed by the slot 605. At that point, plate 1020 is pressed against the distal end of handpiece 100 so that a spring 1025 is compressed and, because the tabs 1000 and 1005 define an arc of 170° while slots 610 and 625 of the handpiece are offset by 180°, tab 1005 is not aligned with slot 625. Once the tab 1000 clears the gap, the hub 1010 is rotated until the tab 1005 aligns with the slot 625 and snaps into place to lock the hub 1010 within the bore. The instrument is removed from the bore by pulling the plate 1020 away from the handpiece 100 until the tab

24

1005 is out of the slot 625 and rotating the hub 1010 until the tab 1000 aligns with the gap in the flange 610.

Referring to Figs. 11A and 11B, the latching mechanism also
5 may be implemented with a spring-loaded plunger 1100 positioned in an indentation 1105 in the hub 1110 of a surgical instrument. A spring 1115 could be a separate component or molded with the plunger 1100.

10 Referring to Fig. 12, the latching mechanism 310 also may be incorporated into an adapter 1200 for connecting a hub of a surgical instrument to a handpiece. The adapter 1200 includes a proximal end 1205 for insertion into the bore 110 of the handpiece and a
15 distal end 1210 configured for attachment to a hub of a surgical instrument.

Other embodiments are within the following claims.

CLAIMS

1. Apparatus for controlling a surgical device, comprising:
a housing; and
5 a magnetic switching element mounted on the housing, the magnetic switching element including:
a magnet,
a magnetic sensor configured to produce a control signal for
controlling the surgical device, and
10 an actuator mounted on the housing for movement between a first position in which a magnetic field of the magnet is decoupled from the magnetic sensor to a second position to couple the magnetic field to the magnetic sensor so as to change a value of the control signal produced by the magnetic sensor.
- 15
2. The apparatus of claim 1, further comprising magnetically soft material, wherein movement of the actuator causes relative movement between the magnet and the magnetically soft material.
- 20 3. The apparatus of claim 2, wherein the magnet is coupled to the actuator so that movement of the actuator causes movement of the magnet.
4. The apparatus of claim 2, wherein the magnetically soft
25 material is configured to substantially absorb the magnetic field produced by the magnet when the actuator is in the first position and not to substantially absorb the magnetic field produced by the magnet when the actuator is in the second position.
- 30 5. The apparatus of claim 1, wherein the magnet is physically isolated from the magnetic sensor.

6. The apparatus of claim 5, wherein the magnet is separated from the magnetic sensor by a wall of the housing.
- 5 7. The apparatus of claim 1, wherein the housing comprises a housing of a surgical handpiece having a motor positioned therein, and wherein the control signal produced by the magnetic sensor is for controlling operation of the motor.
- 10 8. The apparatus of claim 2, wherein the magnetically soft material comprises a switch bottom having a cylindrical opening, wherein the magnet is positioned in the cylindrical opening when the actuator is in the first position, and wherein a portion of the magnet is extended beyond the cylindrical opening when the actuator is in
15 the second position.
9. The apparatus of claim 8, wherein the magnetically soft material further comprises a switch cover secured to the magnet.
- 20 10. The apparatus of claim 9, further comprising a spring configured to bias the switch cover away from the cylindrical opening.
11. The apparatus of claim 10, wherein the switch bottom and the
25 switch cover are mechanically interlocked.
12. The apparatus of claim 8, wherein the cylindrical opening in the switch bottom overlies a depression in an exterior surface of the housing, and wherein the depression is configured to receive the
30 magnet and has a closed bottom.

13. The apparatus of claim 1, wherein the magnetic sensor comprises a Hall-effect device.
14. The apparatus of claim 1, wherein the magnetic sensor
5 comprises a reed switch.
15. The apparatus of claim 1, comprising a plurality of magnetic switching elements.
- 10 16. The apparatus of claim 1, wherein the magnetic sensor is mounted on a substantially flat circuit board that is positioned within the housing.
17. The apparatus of claim 3, wherein a distance between a
15 position of the magnet when the actuator is in the first position and a position of the magnet when the actuator is in the second position is less than 0.1 inches.
18. The apparatus of claim 1, wherein a distance between a
20 position of the magnet when the actuator is in the first position and a position of the magnet when the actuator is in the second position is on the order of 0.06 inches.
19. The apparatus of claim 1 wherein the magnet is positioned
25 outside of the housing.
20. The apparatus of claim 1 wherein the magnetic sensor is position inside the housing.
- 30 21. Apparatus for controlling a surgical device, comprising:
a housing; and

28

a magnetic switching element mounted on the housing, the magnetic switching element including:

a magnet,

a sleeve of magnetically soft material surrounding the

5 magnet,

a magnetic sensor configured to produce a control signal for controlling the surgical device, and

an actuator mounted on the housing for movement between a first position in which the magnet is positioned within the sleeve of magnetically soft material and a magnetic field of the magnet is decoupled from the magnetic sensor to a second position in which a portion of the magnet extends from the sleeve of magnetically soft material and the magnetic field is coupled to the magnetic sensor so as to change a value of the control signal produced by the magnetic sensor.

10

15

22. A surgical system comprising the apparatus of claim 1 together with a surgical instrument.

20 23. The surgical system of claim 22 in kit form.

24. The apparatus substantially as herein described with reference to the accompanying drawings.

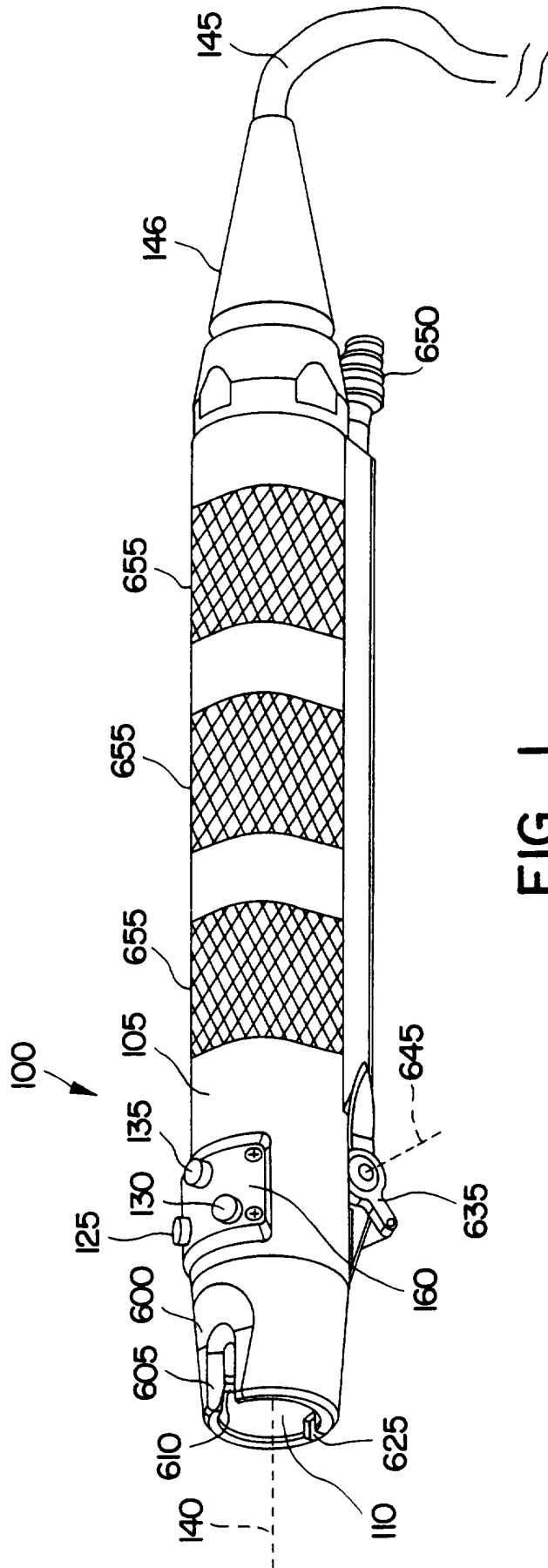

FIG. 1

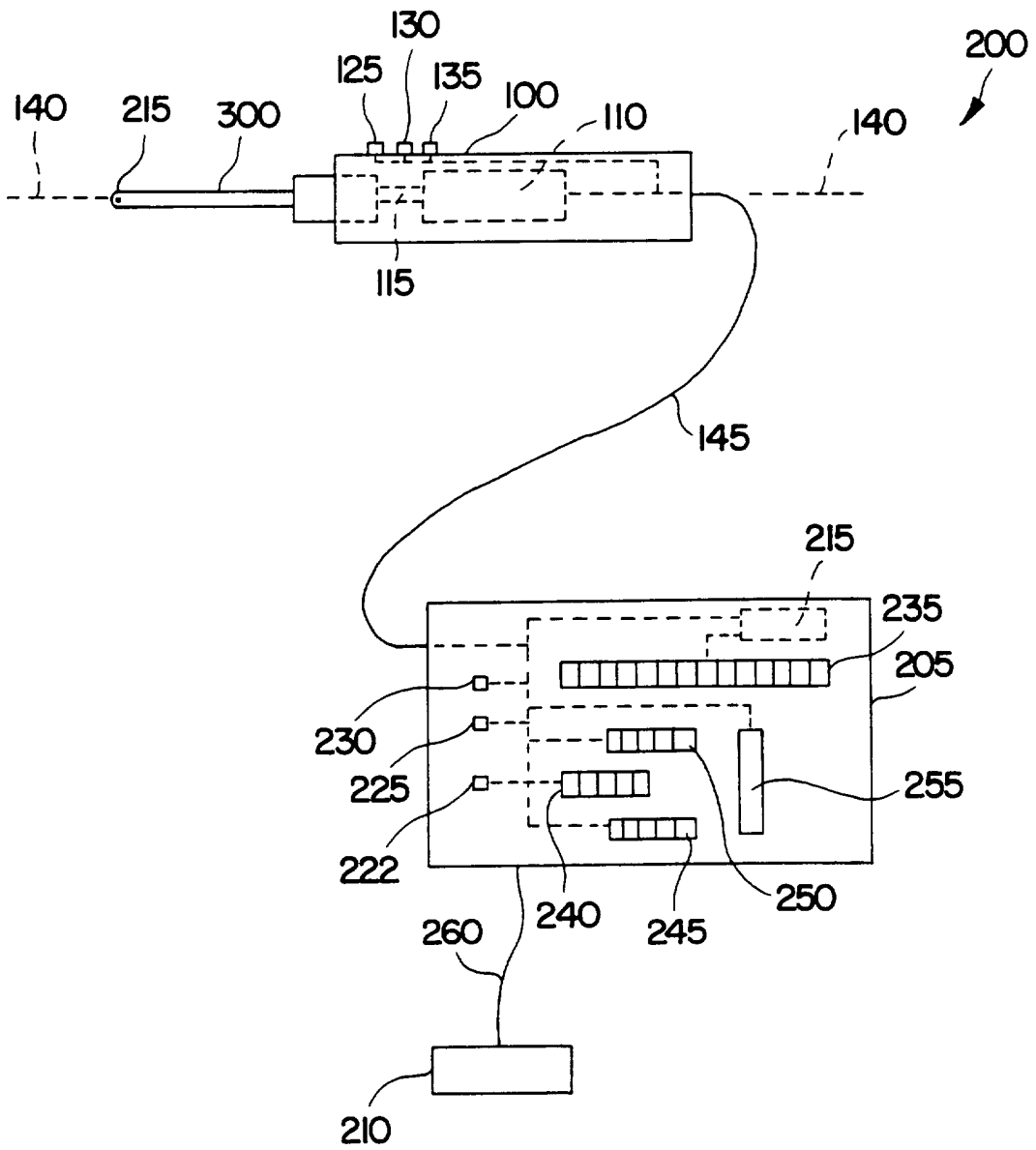

FIG. 2

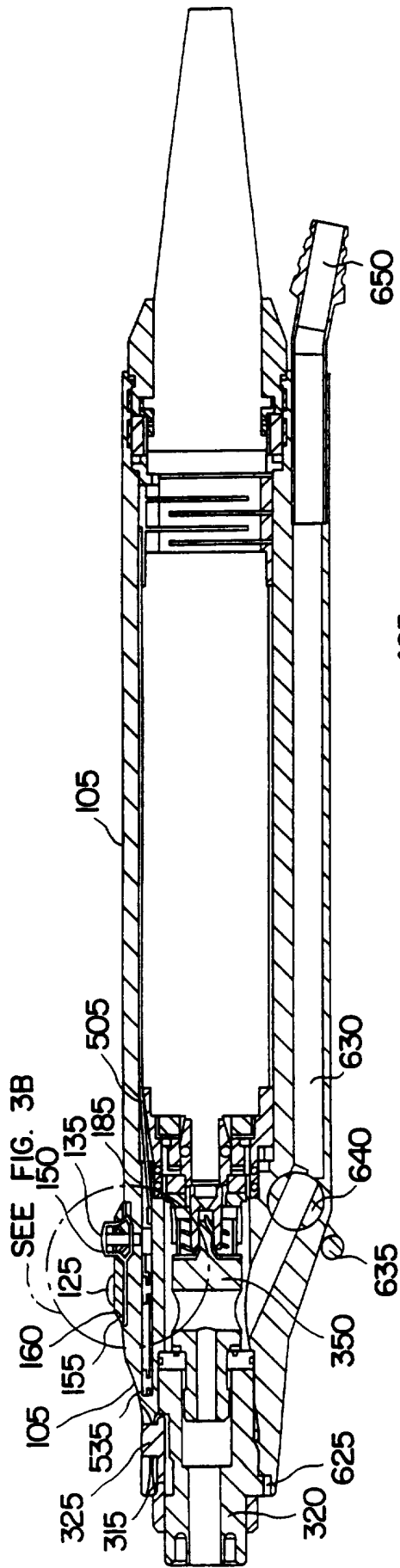

FIG. 3A

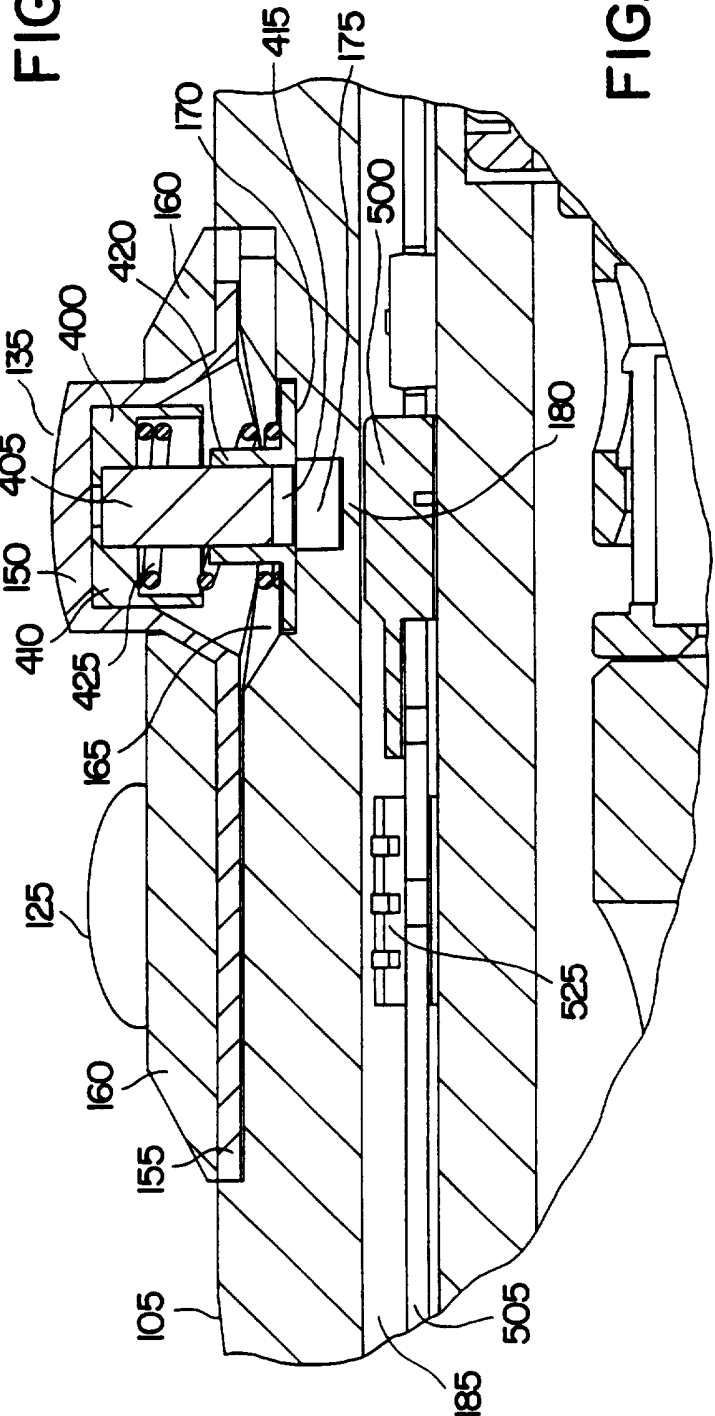

FIG. 3B

4 / 17

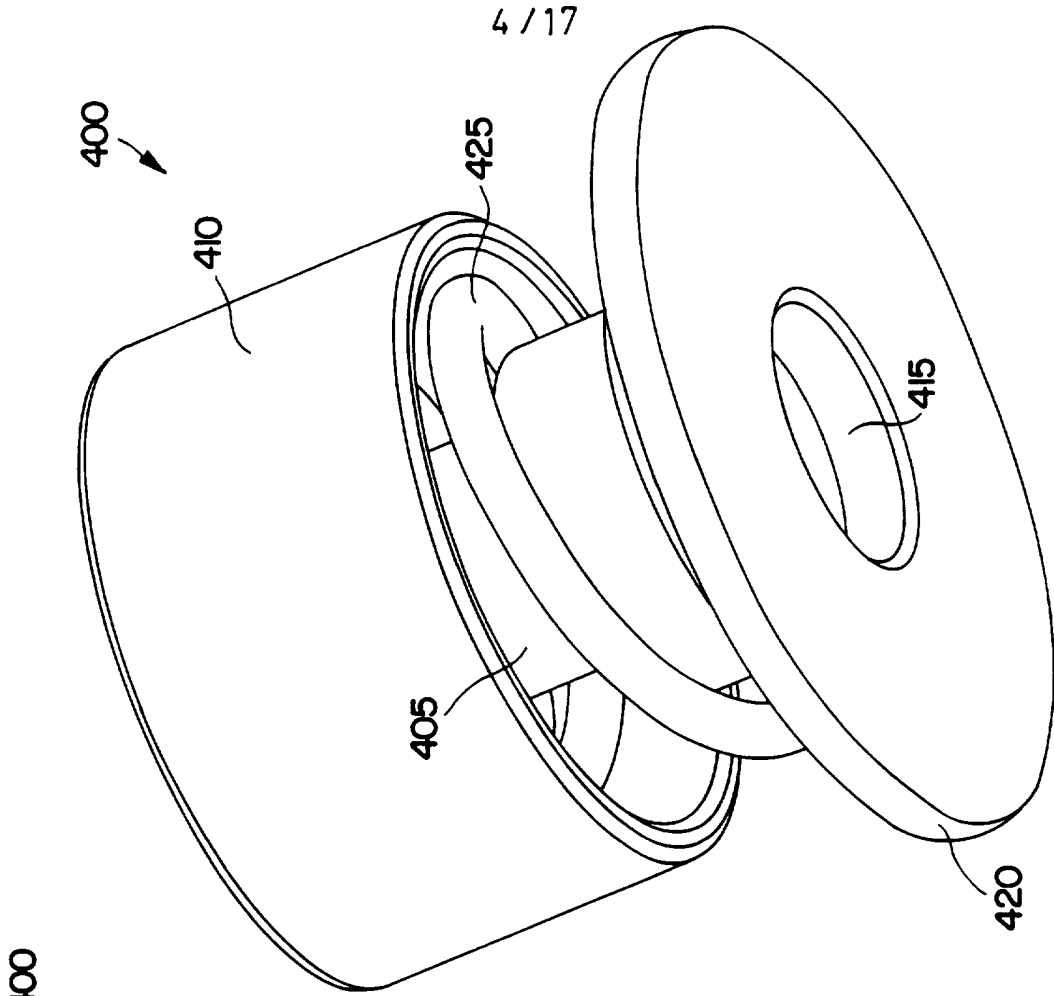

FIG. 4B

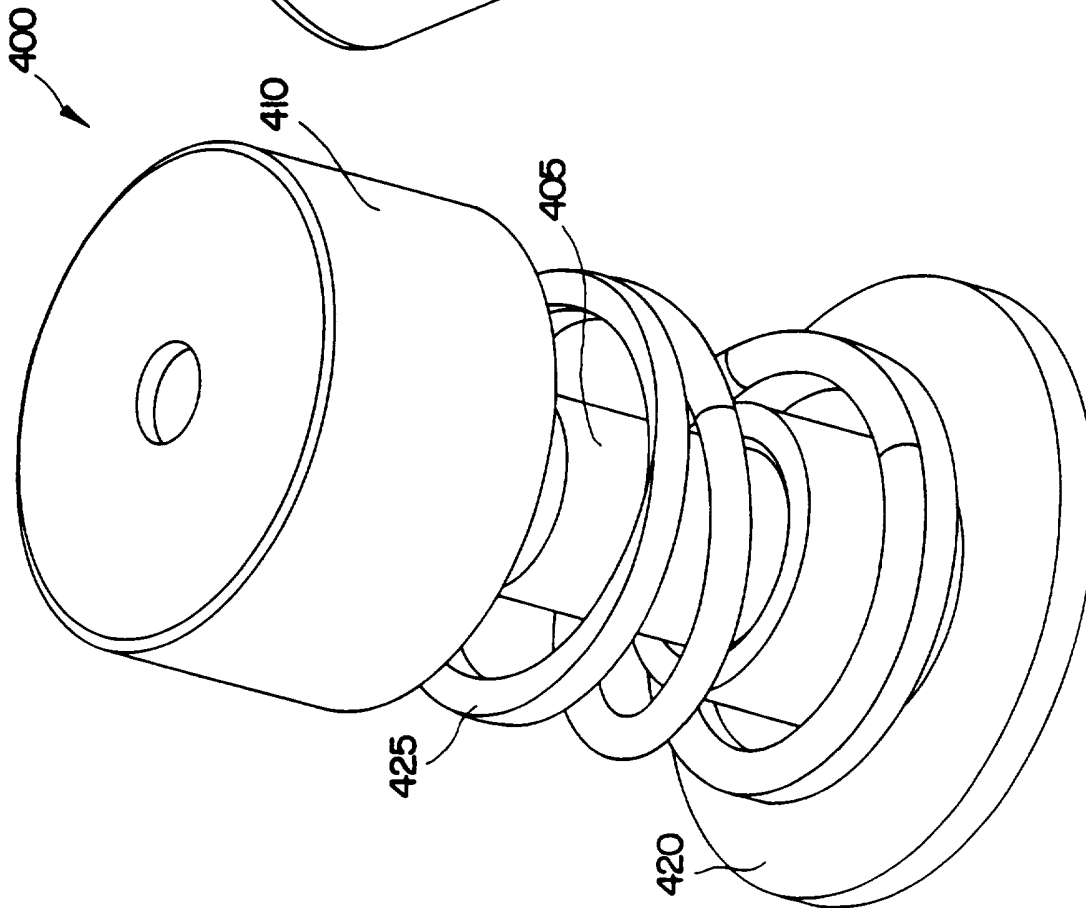

FIG. 4A

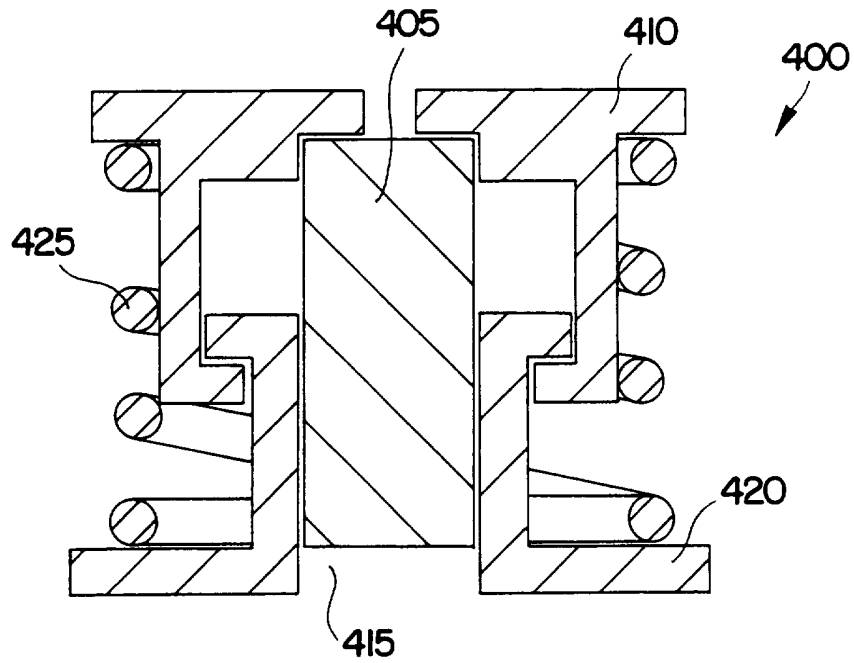

FIG. 4C

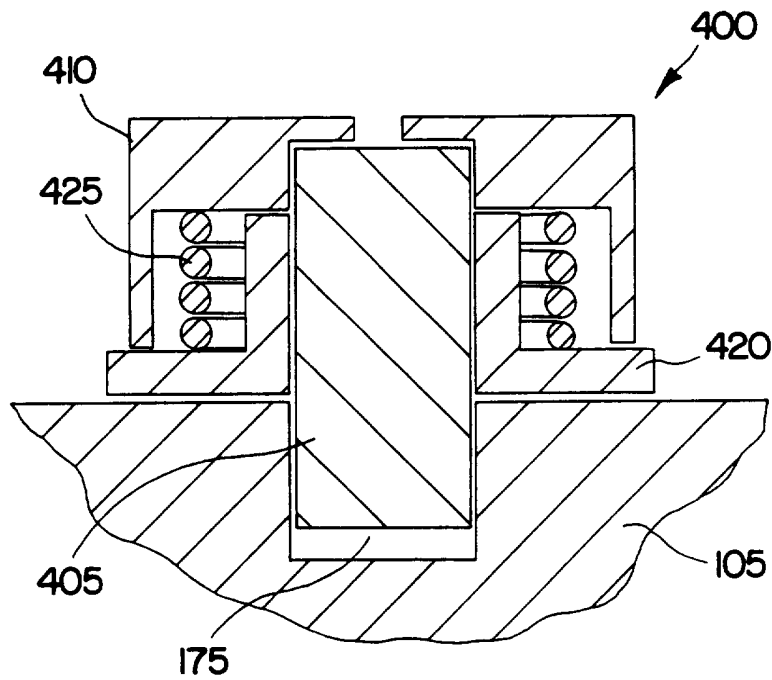

FIG. 4D

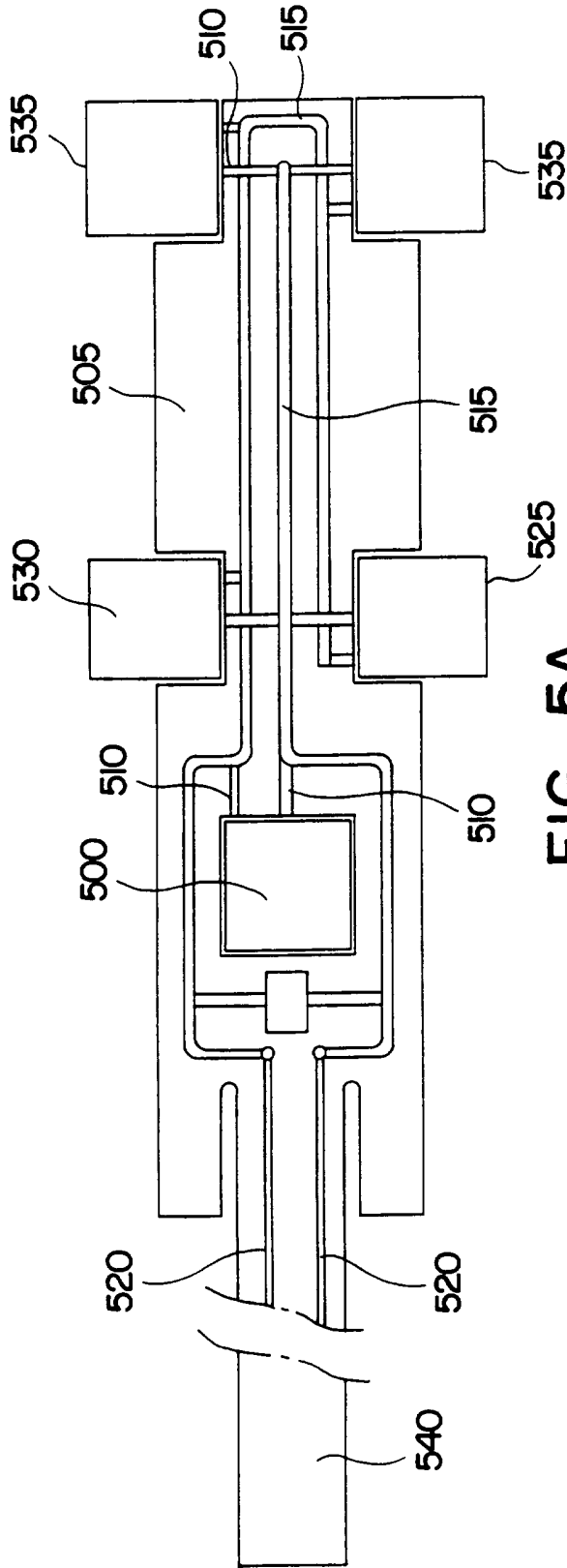

FIG. 5A

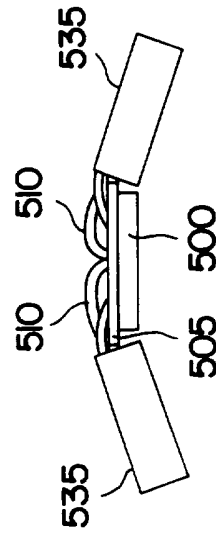

FIG. 5B

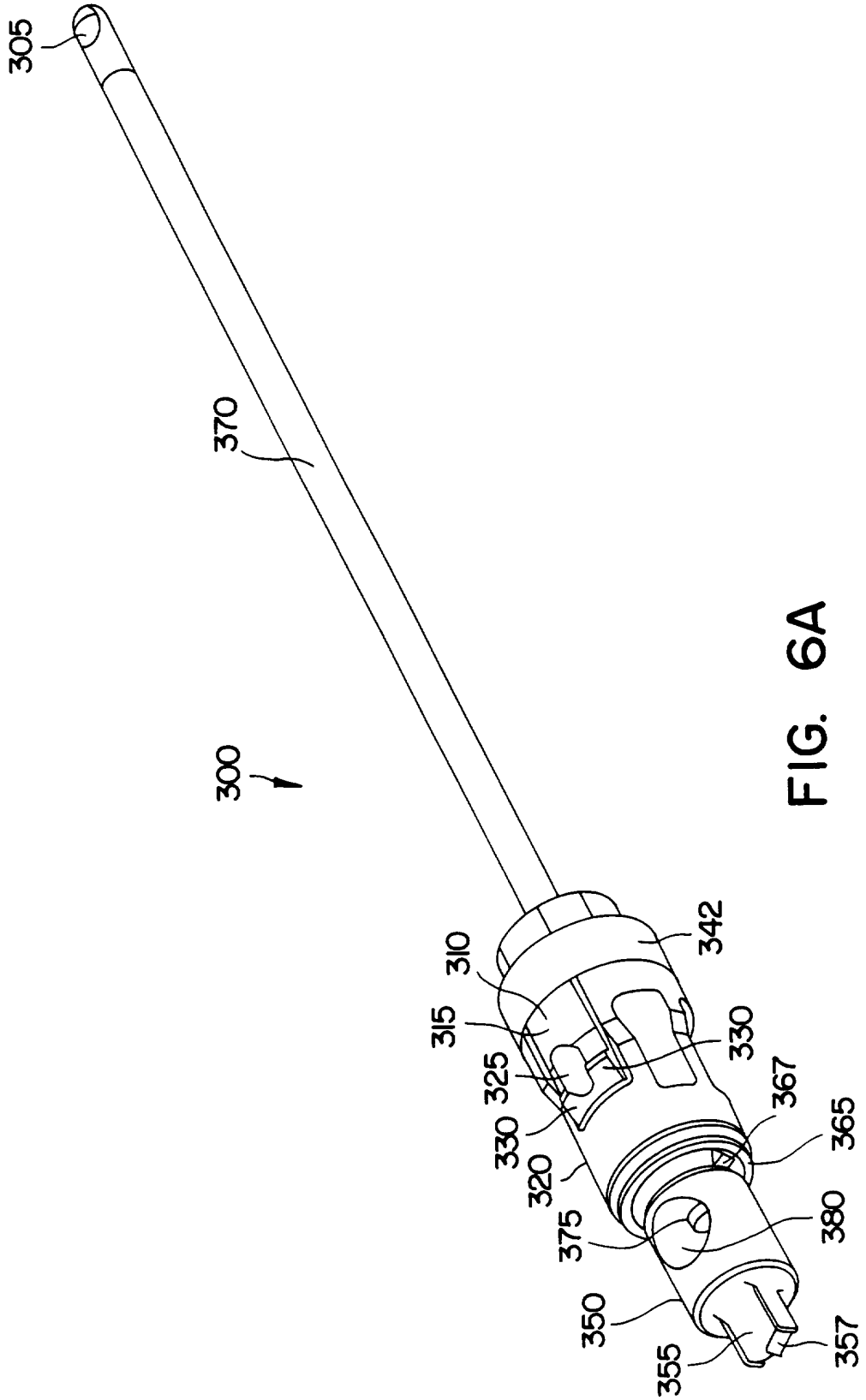

FIG. 6A

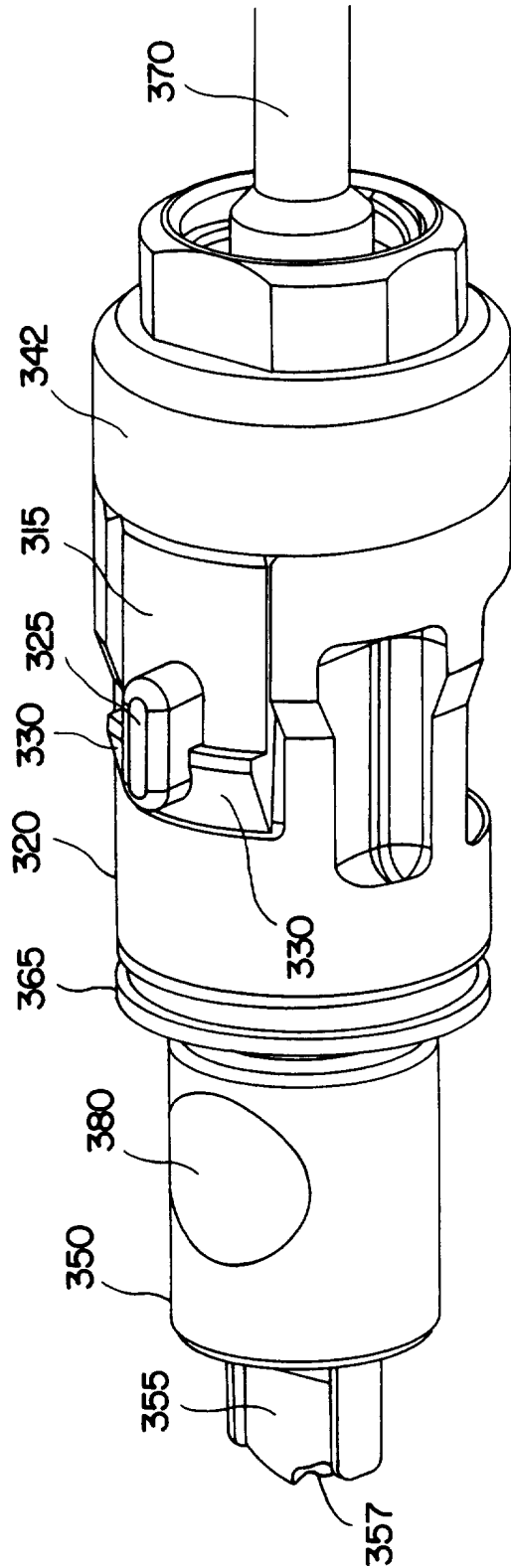

FIG. 6B

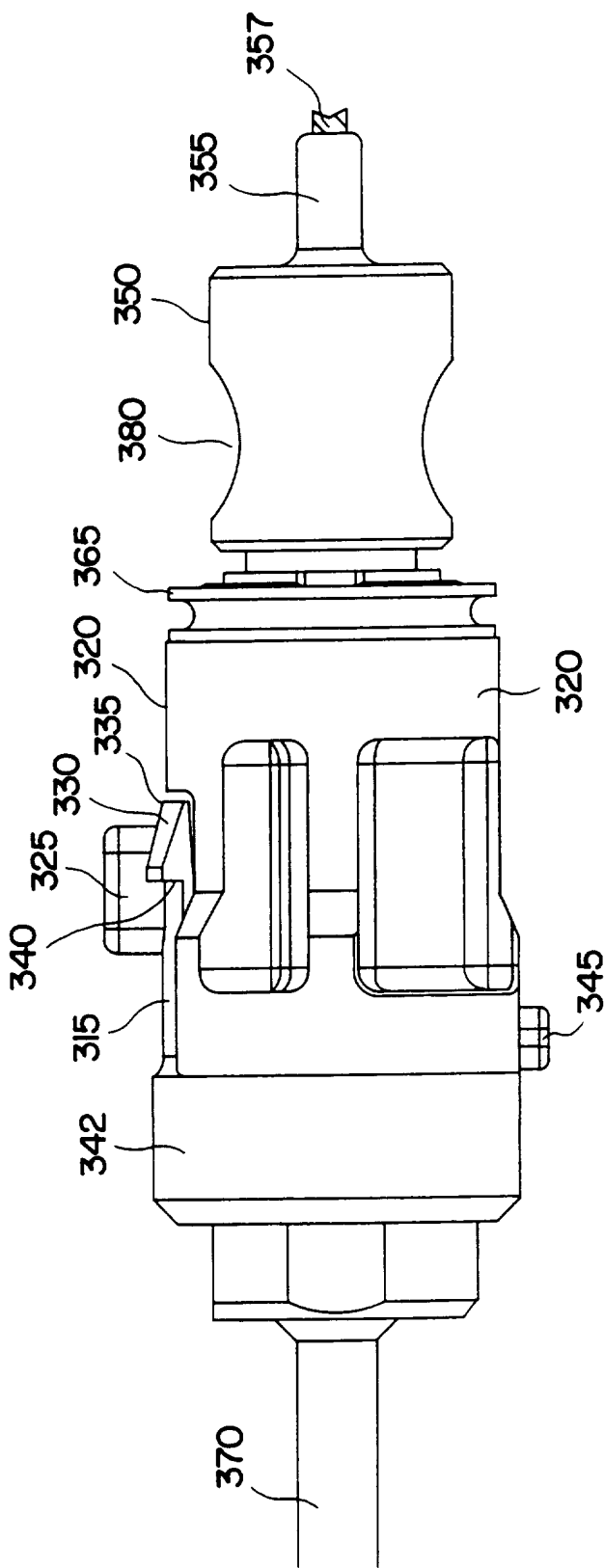

FIG. 6C

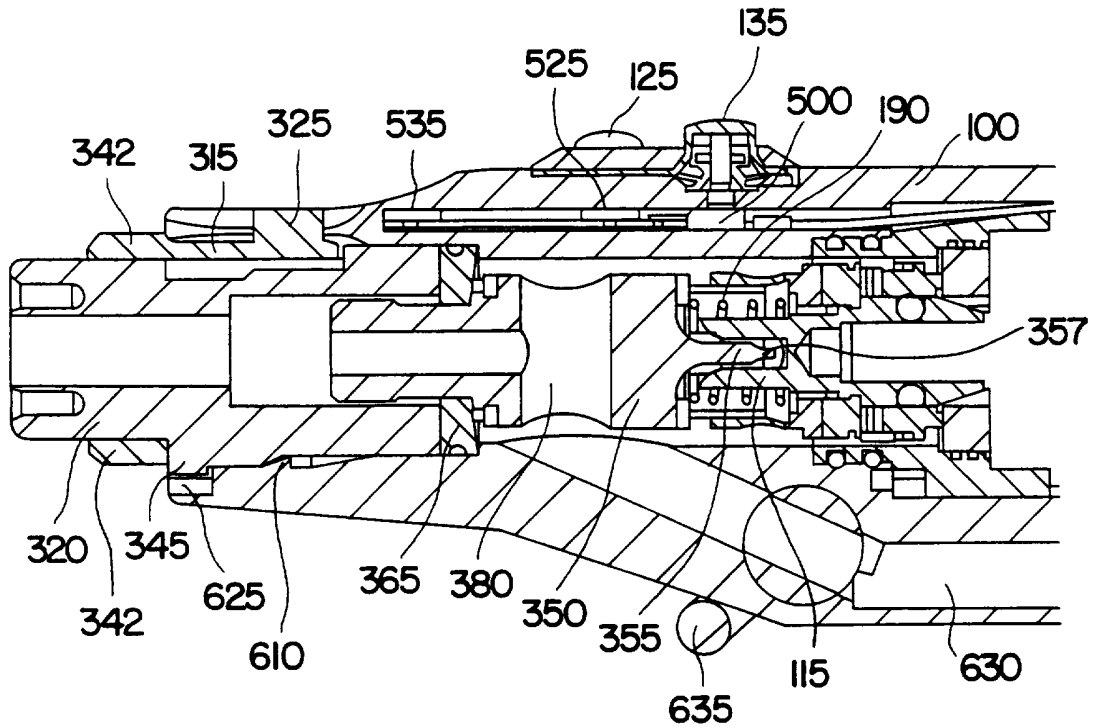

FIG. 7A

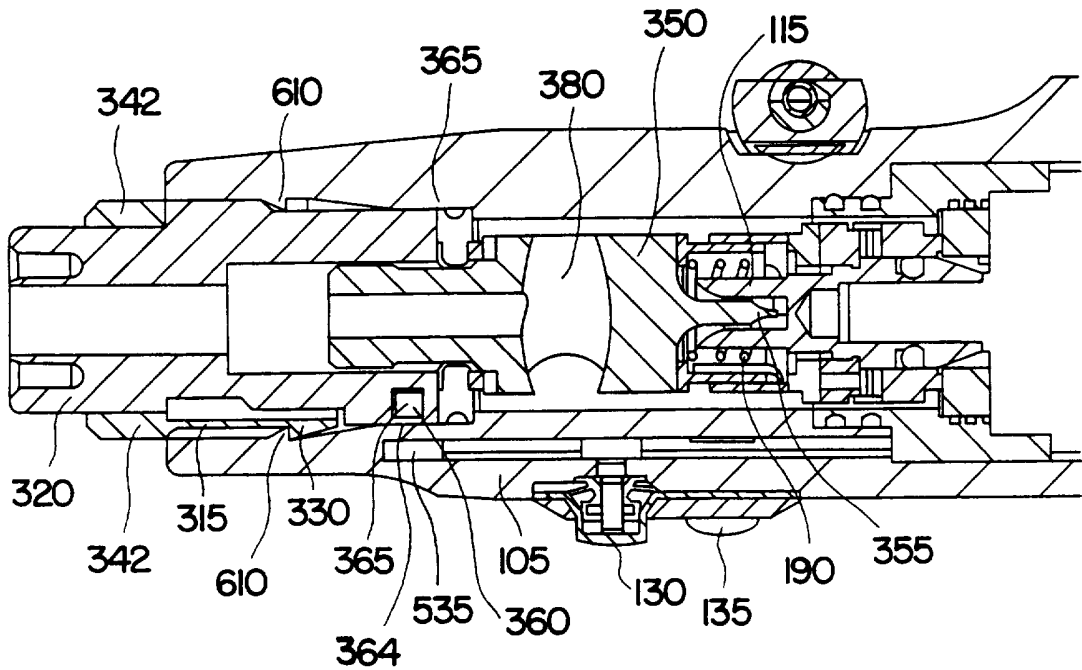

FIG. 7B

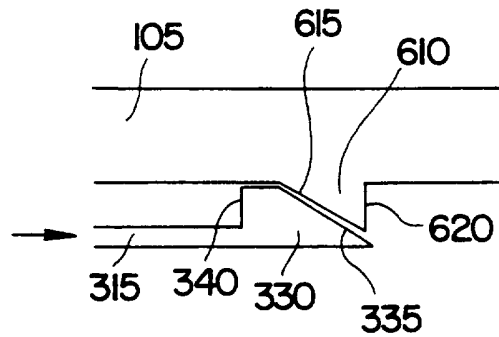

FIG. 8A

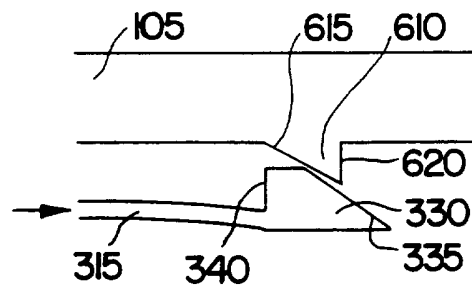

FIG. 8B

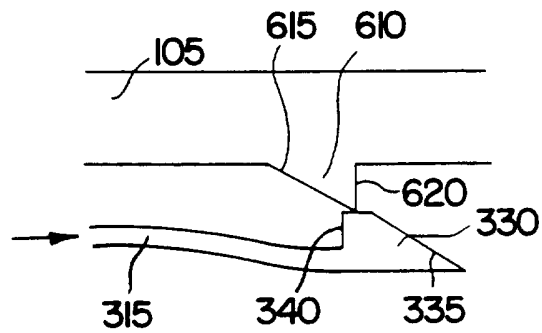

FIG. 8C

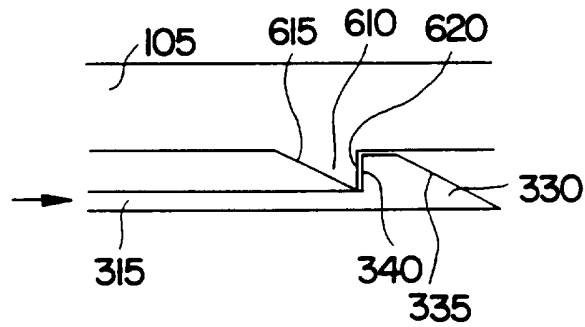

FIG. 8D

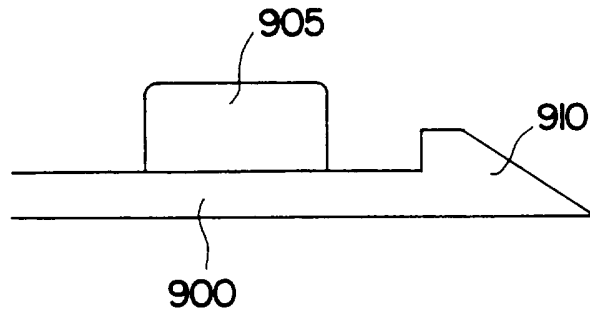

FIG. 9A

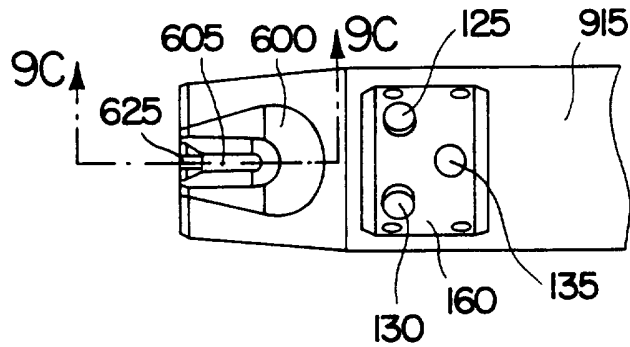

FIG. 9B

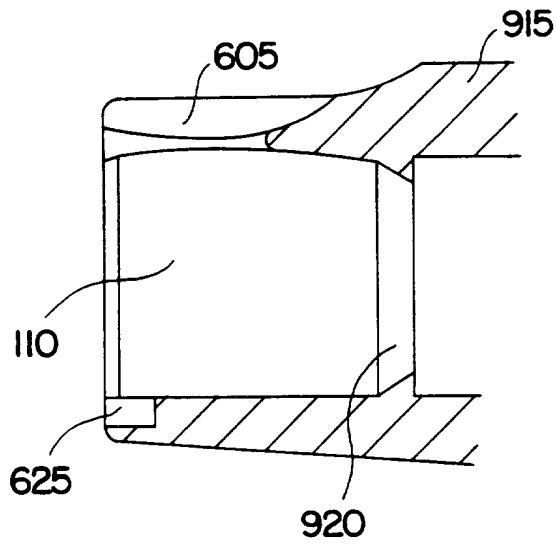

FIG. 9C

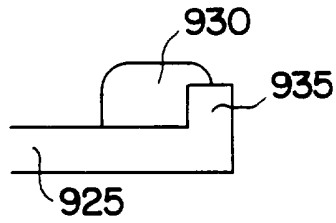

FIG. 9D

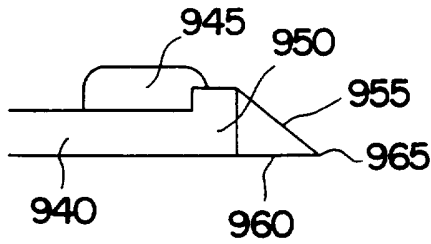

FIG. 9E

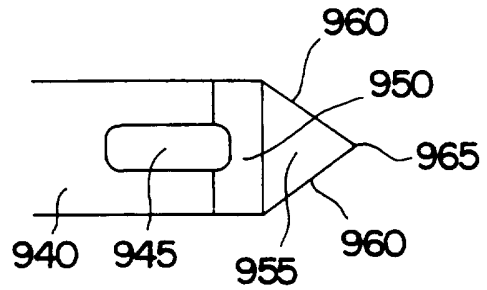

FIG. 9F

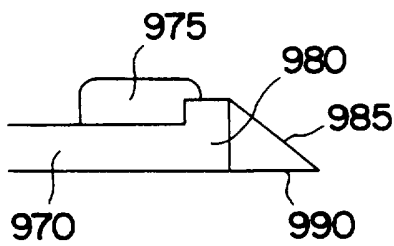

FIG. 9G

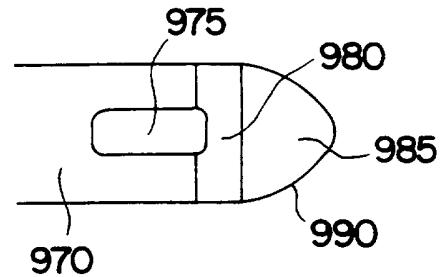

FIG. 9H

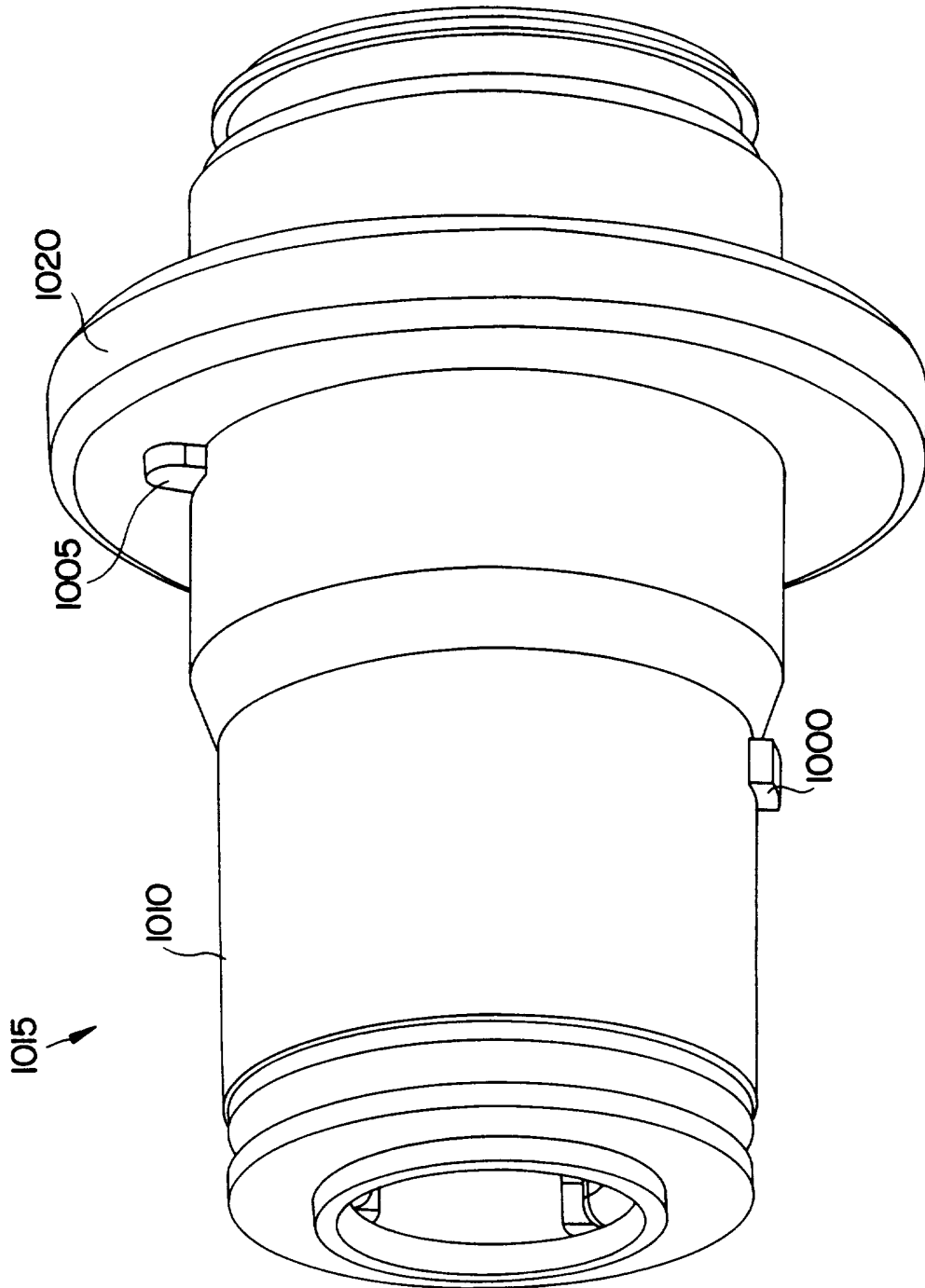

FIG. 10A

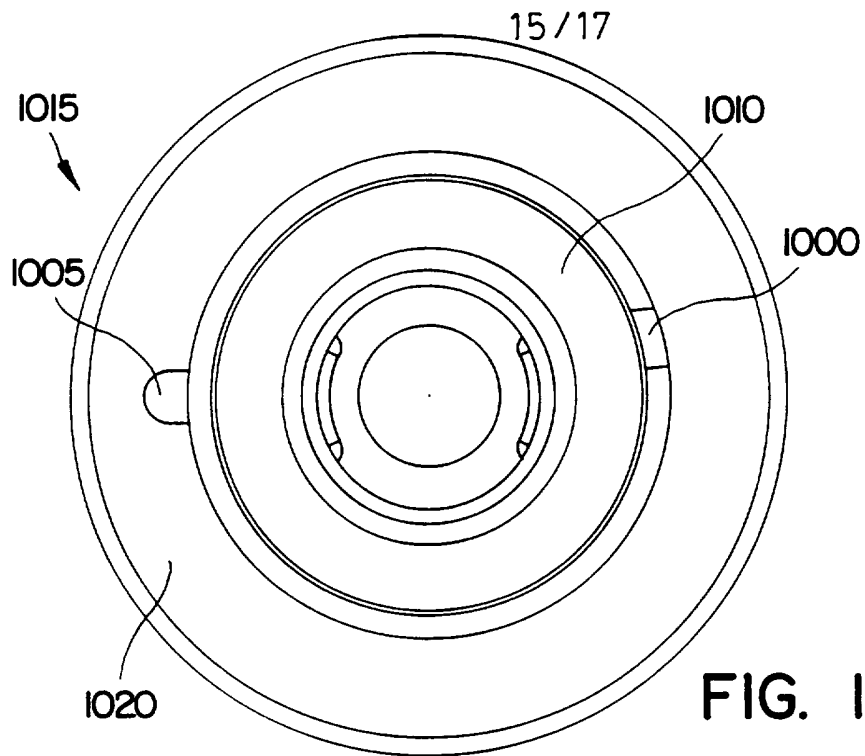

FIG. 10B

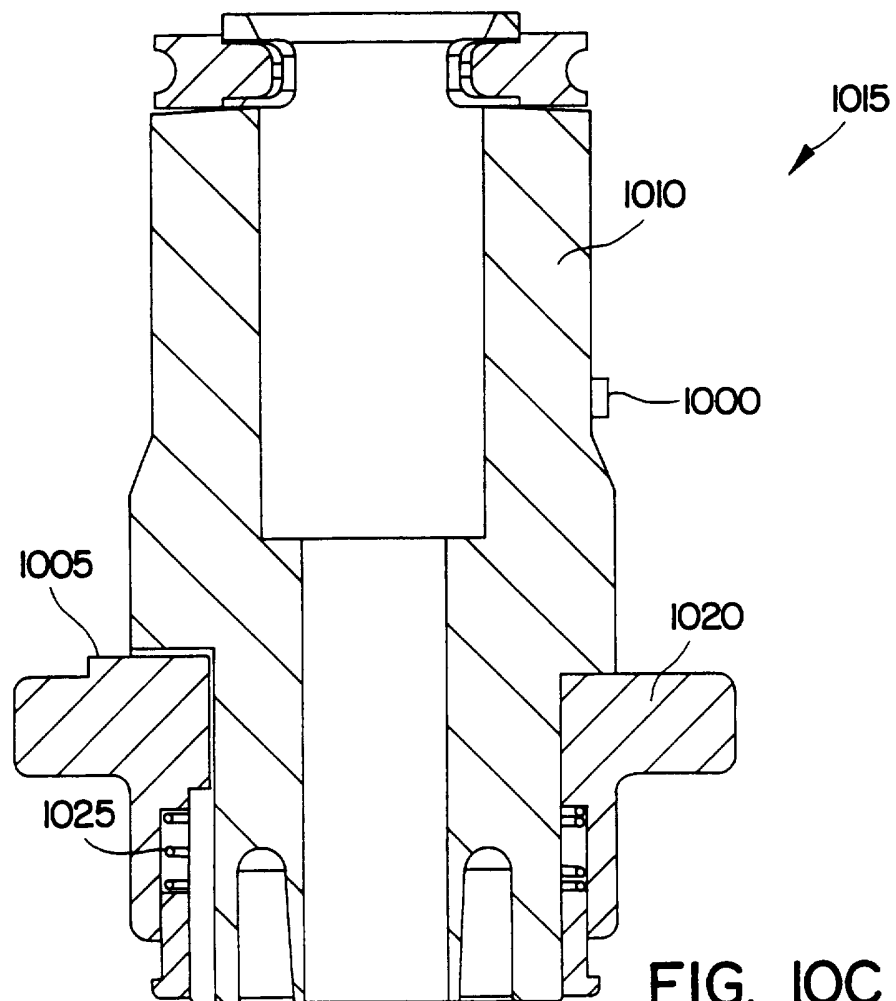

FIG. 10C

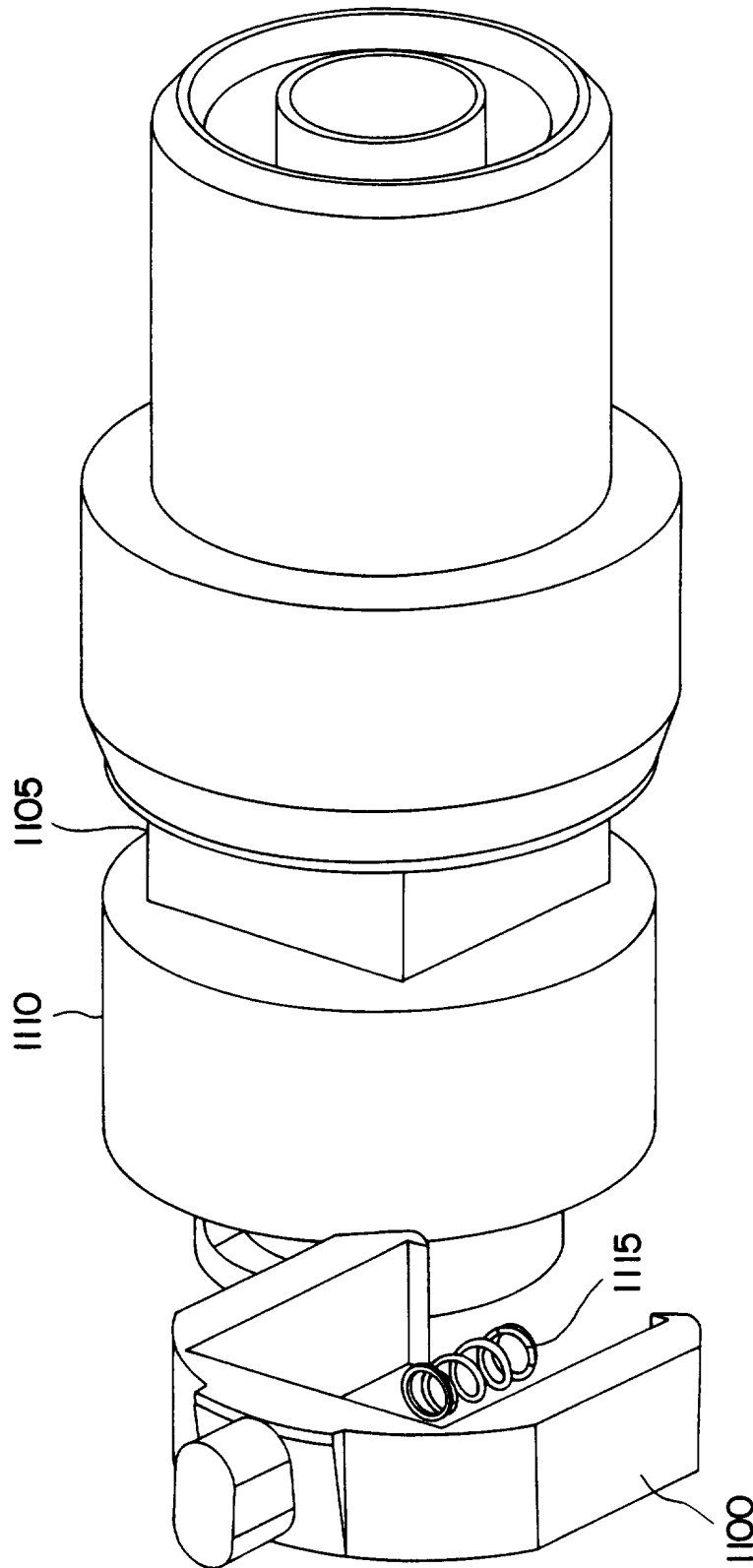

FIG. 11A

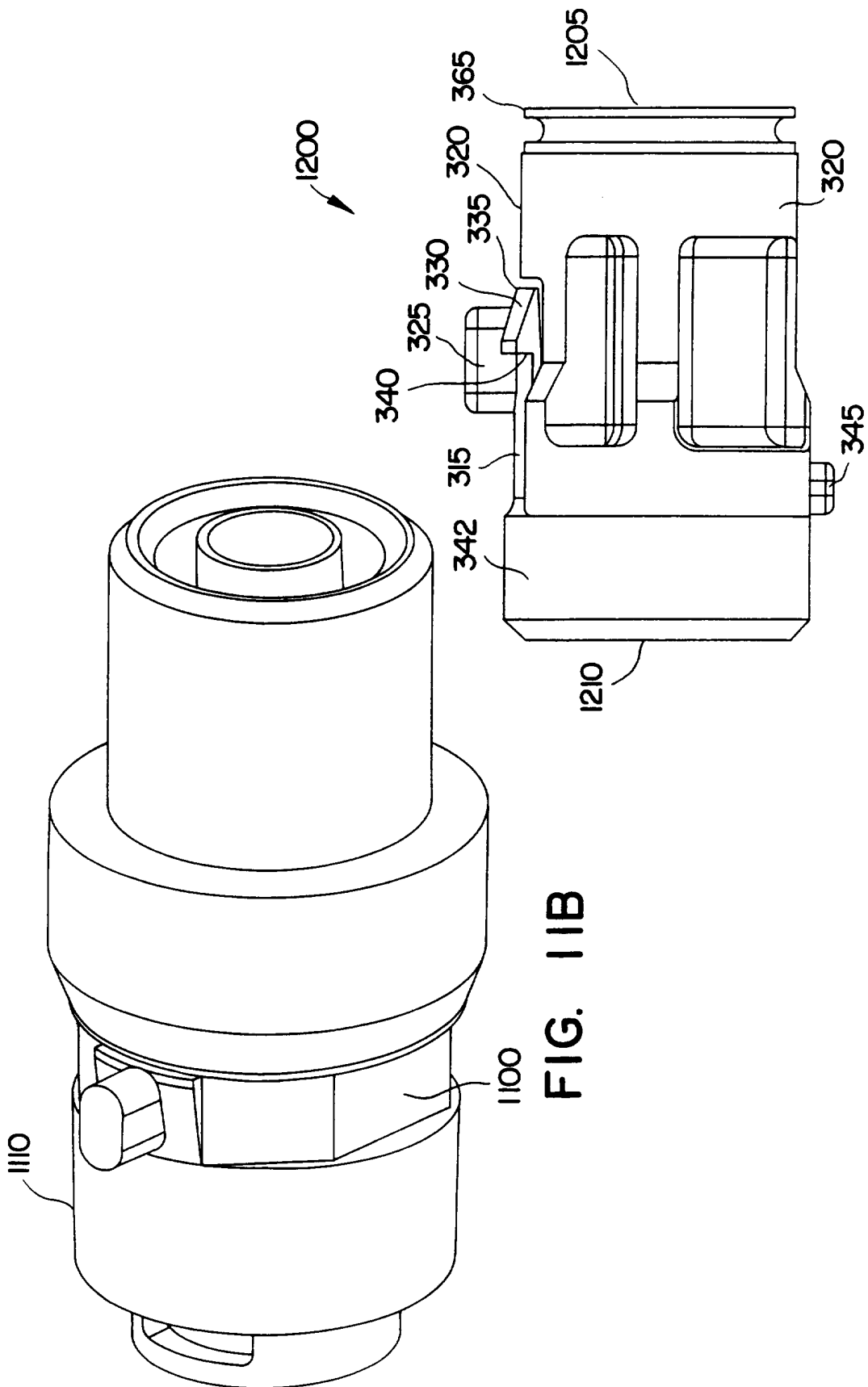

FIG. 11B

FIG. 12

INTERNATIONAL SEARCH REPORT

International application No.
PCT/US96/17625

A. CLASSIFICATION OF SUBJECT MATTER

IPC(6) : A61B 17/20, 17/32, 17/36

US CL : 318/255; 128/303.1, 305; 606/170, 180

According to International Patent Classification (IPC) or to both national classification and IPC

B. FIELDS SEARCHED

Minimum documentation searched (classification system followed by classification symbols)

U.S. : 318/255; 128/303.1, 303.13, 303.14, 303.17, 305; 606/170, 172, 180; 600/9, 13, 14, 15

Documentation searched other than minimum documentation to the extent that such documents are included in the fields searched

Electronic data base consulted during the international search (name of data base and, where practicable, search terms used)

APS, STN

C. DOCUMENTS CONSIDERED TO BE RELEVANT

Category*	Citation of document, with indication, where appropriate, of the relevant passages	Relevant to claim No.
Y	US Re. 34,556 A (SJOSTROM et al.) 01 March 1994 See figures 3-6a elements 34, 34', 36 and 36'.	1-23
Y	US 5,269,794 A (REXROTH) 14 December 1993 See figures 6, 11, 13 and 15 elements 108, 109, and 93.	1-23
Y	US 5,217,478 A (REXROTH) 08 June 1993 See figures 6, 10, 11, 13 and 15 elements 108, 109 and 93.	1-23
Y	US 4,705,038 A (SJOSTROM et al.) 10 Nov. 1987 See figures 3-6a elements 34, 34', 36 and 36'.	1-23

Further documents are listed in the continuation of Box C. See patent family annex.

* Special categories of cited documents:	"T" later document published after the international filing date or priority date and not in conflict with the application but cited to understand the principle or theory underlying the invention
"A" document defining the general state of the art which is not considered to be of particular relevance	"X" document of particular relevance; the claimed invention cannot be considered novel or cannot be considered to involve an inventive step when the document is taken alone
"E" earlier document published on or after the international filing date	"Y" document of particular relevance; the claimed invention cannot be considered to involve an inventive step when the document is combined with one or more other such documents, such combination being obvious to a person skilled in the art
"L" document which may throw doubts on priority claim(s) or which is cited to establish the publication date of another citation or other special reason (as specified)	"&" document member of the same patent family
"O" document referring to an oral disclosure, use, exhibition or other means	
"P" document published prior to the international filing date but later than the priority date claimed	

Date of the actual completion of the international search

11 DECEMBER 1996

Date of mailing of the international search report

25 FEB 1997

Name and mailing address of the ISA/US
Commissioner of Patents and Trademarks
Box PCT
Washington, D.C. 20231

Facsimile No. (703) 305-3230

Authorized officer

SHIK LUEN IP

Telephone No. (703) -308-3098

INTERNATIONAL SEARCH REPORT

International application No.
PCT/US96/17623**Box I Observations where certain claims were found unsearchable (Continuation of item 1 of first sheet)**

This international report has not been established in respect of certain claims under Article 17(2)(a) for the following reasons:

1. Claims Nos.: 24
because they relate to subject matter not required to be searched by this Authority, namely:

Claim 24 recites "The apparatus substantially as herein described with reference to the accompanying drawings." The claim is a picture claim or an omibus type claim.
2. Claims Nos.:
because they relate to parts of the international application that do not comply with the prescribed requirements to such an extent that no meaningful international search can be carried out, specifically:
3. Claims Nos.:
because they are dependent claims and are not drafted in accordance with the second and third sentences of Rule 6.4(a).

Box II Observations where unity of invention is lacking (Continuation of item 2 of first sheet)

This International Searching Authority found multiple inventions in this international application, as follows:

1. As all required additional search fees were timely paid by the applicant, this international search report covers all searchable claims.
2. As all searchable claims could be searched without effort justifying an additional fee, this Authority did not invite payment of any additional fee.
3. As only some of the required additional search fees were timely paid by the applicant, this international search report covers only those claims for which fees were paid, specifically claims Nos.:
4. No required additional search fees were timely paid by the applicant. Consequently, this international search report is restricted to the invention first mentioned in the claims; it is covered by claims Nos.:

Remark on Protest

- The additional search fees were accompanied by the applicant's protest.
 No protest accompanied the payment of additional search fees.