

(19)



(11)

**EP 1 752 608 A2**

(12)

**EUROPEAN PATENT APPLICATION**

(43) Date of publication:  
**14.02.2007 Bulletin 2007/07**

(51) Int Cl.:  
**E21B 15/00 (2006.01)**

(21) Application number: **06254211.3**

(22) Date of filing: **10.08.2006**

(84) Designated Contracting States:  
**AT BE BG CH CY CZ DE DK EE ES FI FR GB GR HU IE IS IT LI LT LU LV MC NL PL PT RO SE SI SK TR**  
Designated Extension States:  
**AL BA HR MK YU**

(72) Inventor: **Belik, Jaroslav Pearland, Texas 77584 (US)**

(74) Representative: **Flint, Adam Beck Greener Fulwood House, 12 Fulwood Place, London WC1V 6HR (GB)**

(30) Priority: **11.08.2005 US 707351 P**

(71) Applicant: **NATIONAL-OILWELL, L.P. Houston, TX 77042 (US)**

**(54) Portable drilling mast structure, rig and method for erecting**

(57) A portable drilling mast structure (200) has a lower drilling mast (202) having a lower end pivotally coupled to a base (110). A hinge (206) is coupled to an upper end of the lower drilling mast (202) and a lower end of an upper drilling mast (204). The drilling mast structure (200) has a first position in which the lower drilling mast

(202) is parallel to the base (110) and the upper drilling mast (204) is disposed between the lower drilling mast (202) and the base (110). The drilling mast structure (200) has a second position wherein the lower drilling mast (202) is perpendicular to the base (110) and the upper drilling mast (204) is aligned with the lower drilling mast (202).

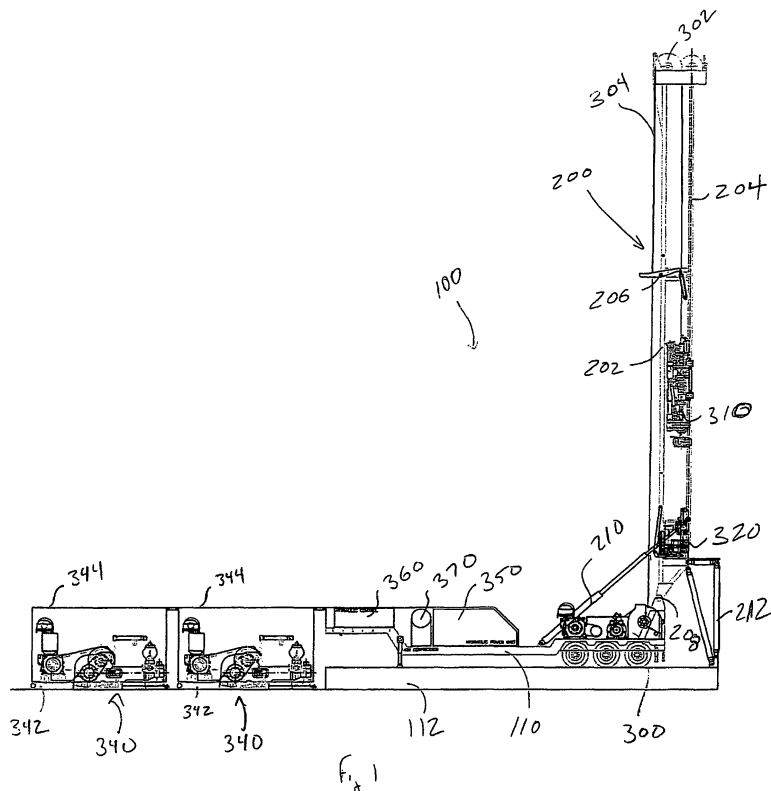

**EP 1 752 608 A2**

## Description

**[0001]** The present invention relates to a portable drilling mast structure, a portable drilling rig and a method for erecting a drilling mast.

**[0002]** The present invention relates generally to mast structures used in drilling wells. In particular embodiments, the present invention relates to portable mast structures used for drilling wells.

**[0003]** In land-based drilling operations it is often desirable to be able to transport a drilling rig to a site where the drilling operations will take place and then be able to move the rig to the next site once operations are complete. Drilling rigs comprises a plurality of systems that all must be interconnected and assembled to support drilling activities. The process of disassembling, transporting, and reassembling a drilling rig is complex and time consuming.

**[0004]** The components and systems that make up a drilling rig are generally transported on trailers between drilling sites. Once on site, the components have to be unloaded and assembled. Drilling cannot commence until the entire rig is unloaded and assembled. In many instances, the operators of the drilling rigs only collect rental fees when the rigs are involved in drilling operations. Therefore, the time and expenses involved in transporting and assembling a drilling rig are preferably minimized. In many cases, auxiliary equipment, such as a crane and/or forklift, is required to assemble the drilling rig. This auxiliary equipment must also be transported between drilling sites, further adding to the complexity and cost of moving a rig.

**[0005]** Thus, there remains a need in the art for systems and methods for transporting and assembling portable drilling rigs, which overcome some of the foregoing difficulties while providing more advantageous overall results.

**[0006]** According to a first aspect of the present invention, there is provided a portable drilling mast structure, the mast structure comprising: a lower drilling mast having a lower end pivotally coupled to a base; a hinge coupled to an upper end of said lower drilling mast; and, an upper drilling mast having a lower end coupled to said hinge, wherein the drilling mast structure has a first position wherein said lower drilling mast is substantially parallel to the base and said upper drilling mast is disposed between said lower drilling mast and said base, and a second position wherein said lower drilling mast is substantially perpendicular to said base and said upper drilling mast is aligned with said lower drilling mast.

**[0007]** According to a second aspect of the present invention, there is provided a portable drilling rig, the portable drilling rig comprising: a base; a folding drilling mast comprising a lower drilling mast pivotally coupled to said base and an upper drilling mast coupled to the lower drilling mast by a hinge, wherein the folding drilling mast has a first position wherein said lower drilling mast is parallel to the base and said upper drilling mast is disposed be-

tween said lower drilling mast and said base, and a second position wherein said lower drilling mast is perpendicular to said base and said upper drilling mast is aligned with said lower drilling mast; a drawworks coupled to the base; a sheave mounted to the upper end of said upper drilling mast; a cable extending from said drawworks and over said sheave; and, a top drive disposed within said folding drilling mast and coupled to said cable.

**[0008]** According to a third aspect of the present invention, there is provided a method for erecting a drilling mast, the method comprising: pivotally coupling a lower drilling mast to a base, wherein an upper drilling mast is coupled to the lower drilling mast by a hinge, wherein the lower drilling mast is parallel to the base and the upper drilling mast is disposed between the lower drilling mast and the base; fixing the upper drilling mast to the lower drilling mast so as to prevent rotation about the hinge; pivoting the upper drilling mast and the lower drilling mast to an elevated position; unfixing the upper drilling mast from the lower drilling mast so as to allow rotation about the hinge; pivoting the lower drilling mast toward horizontal such the upper drilling mast rotates about the hinge until the upper drilling mast is aligned with the lower drilling mast in a substantially horizontal position; fixing the upper drilling mast to the lower drilling mast so as to prevent rotation about the hinge; and, pivoting the aligned upper and lower drilling masts to a substantially vertical position.

**[0009]** Embodiments of the present invention include a portable drilling mast structure comprising a lower drilling mast having a lower end pivotally coupled to a base. A hinge is coupled to an upper end of the lower drilling mast and a lower end of an upper drilling mast. The drilling mast structure has a first position wherein the lower drilling mast is parallel to the base and the upper drilling mast is disposed between the lower drilling mast and the base. The drilling mast structure has a second position wherein the lower drilling mast is perpendicular to the base and the upper drilling mast is aligned with the lower drilling mast.

**[0010]** Embodiments of the present invention will now be described by way of example with reference to the accompanying drawings, in which:

Figure 1 is an elevation view of an example of an erected drilling mast constructed in accordance with an embodiment of the present invention;

Figure 2 illustrates the drilling mast of Figure 1 collapsed for transport;

Figure 3 illustrates the drilling mast of Figure 1 collapsed and positioned at a drill site;

Figure 4 illustrates the drilling mast of Figure 1 in an upright position with the upper drilling mast folded down;

Figure 5 illustrates the drilling mast of Figure 1 as the upper drilling mast is rotated relative to the lower drilling mast;

Figure 6 illustrates the drilling mast of Figure 1 in a horizontal position with the upper drilling mast aligned with the lower drilling mast;

Figure 7 illustrates a folding drilling mast configured for use with an elevated substructure;

Figure 8 illustrates the folding drilling mast of Figure 7 connected to the substructure; and,

Figure 9 illustrates the drilling mast of Figure 7 in an operational position.

**[0011]** Referring now to Figure 1, drilling rig 100 comprises folding drilling mast 200, drawworks 300, top drive 310, iron roughneck 320, mud pumps 340, hydraulic power unit 350, hydraulic control unit 360, and compressor 370. Folding drilling mast 200, drawworks 300, hydraulic power unit 350, hydraulic control unit 360, and compressor 370 are mounted to trailer 110, which is positioned on ramp 112. Top drive 310 and iron roughneck 320 are mounted to folding drilling mast 200. Top drive 310 is coupled to cable 304, which is run over sheaves 302 at the top of folding drilling mast 200 to drawworks 300. Mud pumps 340 are mounted to skids 342 each having an upper surface 344.

**[0012]** Folding drilling mast 200 comprises lower drilling mast 202 and upper drilling mast 204 connected by hinge 206. Lower drilling mast 202 is rotatably coupled to trailer 110 by pivot 208. Main hydraulic cylinder 210 is coupled to trailer 110 and lower drilling mast 202. Support structure 212 couples lower drilling mast 202 to ramp 112 once drilling mast 200 is fully erected. Sheaves 302 are mounted to the top of upper drilling mast 204.

**[0013]** Referring now to Figure 2, folding drilling mast 200 can be collapsed and transported on trailer 110 via truck 114. Top drive 310 and iron roughneck 320 may remain installed on folding drilling mast 200 during transport and installation. When collapsed for transport, upper drilling mast 202 is stored below and latched to lower drilling mast 204. Upper drilling mast 202 remains coupled to lower drilling mast 204 at hinge 206. Lower drilling mast 204 is coupled to trailer 110 at pivot 208.

**[0014]** Once at the drilling site, trailer 110 is driven onto ramp 112 and secured in place, as is shown in Figure 3. Mud pumps 340 are also placed adjacent to ramp 112 such that their upper surfaces 344 are aligned with the upper surface 116 of trailer 112. Folding drilling mast 200 is erected by extending hydraulic cylinder 210 so as to rotate the drilling mast about pivot 208. Drilling mast 200 is rotated until in a substantially vertical position, as shown in Figure 4. Once in the vertical position, upper drilling mast 204 is unlatched from lower drilling mast 202 by releasing connection 214.

**[0015]** Once upper drilling mast 204 is unlatched, hydraulic cylinder 210 is retracted so that lower drilling mast 202 moves back toward a horizontal position. As lower drilling mast 202 rotates, the force of gravity will cause upper drilling mast 204 to rotate about hinge 206. As upper drilling mast 204 rotates, upper cylinder 216 and pivot arm 218 between the lower and upper drilling masts 202,204 engage the upper drilling mast 204. As lower drilling mast 202 is lowered, upper drilling mast 204 will contact upper surfaces 344 of the mud pumps 340. Pivot arm 218 acts to control the rate at which upper drilling mast 204 rotates and makes sure that the upper drilling mast 204 rotates past vertical as it contacts upper surfaces 344.

**[0016]** As lower drilling mast 202 moves toward horizontal, upper drilling mast 204 slides along upper surfaces 344 until both the upper and lower drilling masts 204,202 are aligned and in a substantially horizontal position, as shown in Figure 6. Once aligned, upper drilling mast 204 is connected to lower drilling mast 202 and folding drilling mast 200 can be configured for drilling operations. Once upper drilling mast 204 is connected to lower drilling mast 202, hydraulic cylinder 210 can be extended, which will rotate folding drilling mast 200 to the vertical position as shown in Figure 1. Once fully vertical, support structure 212 can be connected to drilling mast 200 so as to reinforce the drilling mast 200 during drilling operations.

**[0017]** Folding drilling mast 200 is collapsed for storage and transport by reversing the installation procedure described above. Support structure 212 is removed and hydraulic cylinder 210 is retracted to lower folding drilling mast 200 to the horizontal position of Figure 6. Once horizontal, upper drilling mast 204 is partially disconnected from lower drilling mast 202 so that it can rotate about hinge 206. Hydraulic cylinder 210 is then extended to raise lower drilling mast 202 back toward a vertical position. As lower drilling mast 202 is raised, upper drilling mast 204 will rotate about hinge 206 as is shown in Figure 5.

**[0018]** As lower drilling mast 202 reaches vertical, as shown in Figure 4, upper drilling mast 204 will be positioned adjacent to the lower drilling mast 202. Connector 214 is then engaged so that the position of upper drilling mast 204 relative to lower drilling mast 202 is maintained as hydraulic cylinder 210 is retracted. The retraction of hydraulic cylinder 210 lowers drilling mast 200 back to a horizontal position where it is fully collapsed and ready for transport, as shown in Figures 2 and 3.

**[0019]** Figures 7 to 9 illustrate a folding drilling mast 400 being installed on substructure 500. Folding drilling mast 400 is transported to a drilling site via trailer 410. Folding drilling mast 400 comprises lower drilling mast 402 and upper drilling mast 404 that are rotatably coupled at hinge 408. Substructure 500 comprises platform 502, hydraulic cylinder 504, and legs 506. Connections 508 and 510 extend from the top of platform 502.

**[0020]** Referring now to Figure 7, folding drilling mast

400 is moved into a position adjacent to substructure 500. The base of folding drilling mast 400 is moved onto platform 502 such that lower drilling mast 402 is rotatably coupled to connection 508, as shown in Figure 8. Erecting arm 406 is extended from lower drilling mast 402 and is connected to cable 512. Folding drilling mast 400 is erected using substantially the same process as described with reference to Figures 3 to 6. As hydraulic cylinder 504 is extended, platform 502 will raise and cable 512 will pull arm 406 such that drilling mast 400 rotates about connection 508. Once drilling mast 400 is fully vertical, as shown in Figure 9, lower drilling mast 402 is coupled to connection 510 and the drilling mast is secured for drilling operations.

**[0021]** Embodiments of the present invention have been described with particular reference to the examples illustrated. However, it will be appreciated that variations and modifications may be made to the examples described within the scope of the present invention.

## Claims

1. A portable drilling mast structure (200,400), the mast structure (200,400) comprising:
  - a lower drilling mast (202,402) having a lower end pivotally coupled to a base (110,500);
  - a hinge (206,408) coupled to an upper end of said lower drilling mast (202,402); and,
  - an upper drilling mast (204,404) having a lower end coupled to said hinge (206,408), wherein the drilling mast structure (200,400) has a first position wherein said lower drilling mast (202,402) is substantially parallel to the base (110,500) and said upper drilling mast (204,404) is disposed between said lower drilling mast (202,402) and said base (110,500), and a second position wherein said lower drilling mast (202,402) is substantially perpendicular to said base (110,500) and said upper drilling mast (204,404) is aligned with said lower drilling mast (202,402).
2. A mast structure according to claim 1, comprising a latch (214) that couples said upper drilling mast (204,404) to said lower drilling mast (202,402) when the drilling mast structure (200,400) is in the first position.
3. A mast structure according to claim 1 or claim 2, comprising a hydraulic cylinder (210) coupled between said lower drilling mast (202) and the base (110), wherein extension of said hydraulic cylinder (210) pivots said lower drilling mast (202) relative to the base (110).
4. A mast structure according to claim 3, wherein said base (110) is a portable trailer (110).
5. A mast structure according to claim 4, comprising a hydraulic power unit mounted on the trailer (110), wherein said hydraulic power unit is operable to provide pressurized hydraulic fluid to said hydraulic cylinder (210).
6. A mast structure according to any of claims 1 to 5, comprising:
  - a drawworks (300) coupled to the base (110);
  - a sheave (302) mounted to the upper end of said upper drilling mast (204,404); and,
  - a cable (304) extending from said drawworks (300) and over said sheave (302).
7. A mast structure according to claim 6, comprising a top drive (310) coupled to said cable (304).
8. A mast structure according to claim 6 or claim 7, comprising an iron roughneck (320) disposed within said lower drilling mast (202).
9. A mast structure according to any of claims 1 to 8, comprising a support structure (212) coupled to said lower drilling mast (202) and the base (110) when said lower drilling mast (202) is perpendicular to the base (110).
10. A portable drilling rig, the portable drilling rig (100) comprising:
  - a base (110);
  - a folding drilling mast (200) comprising a lower drilling mast (202) pivotally coupled to said base (110) and an upper drilling mast (204) coupled to the lower drilling mast (202) by a hinge (206), wherein the folding drilling mast (200) has a first position-wherein said lower drilling mast (202) is parallel to the base (110) and said upper drilling mast (204) is disposed between said lower drilling mast (202) and said base (110), and a second position wherein said lower drilling mast (202) is perpendicular to said base (110) and said upper drilling mast (204) is aligned with said lower drilling mast (202);
  - a drawworks (300) coupled to the base (110);
  - a sheave (302) mounted to the upper end of said upper drilling mast (204);
  - a cable (304) extending from said drawworks (300) and over said sheave (302); and,
  - a top drive (310) disposed within said folding drilling mast (200) and coupled to said cable (304).
11. A portable drilling rig according to claim 10, comprising a latch (214) that couples said upper drilling mast

(204) to said lower drilling mast (202) when the drilling mast (200) is in the first position.

- 12. A portable drilling rig according to claim 10 or claim 11, comprising a hydraulic cylinder (210) coupled between said lower drilling mast (202) and the base (110), wherein extension of said hydraulic cylinder (210) pivots said lower drilling mast (202) relative to the base (110).
- 13. A portable drilling rig according to claim 12, wherein said base (110) is a portable trailer (110).
- 14. A portable drilling rig according to claim 13, comprising a hydraulic power unit mounted on the trailer (110), wherein said hydraulic power unit is operable to provide pressurized hydraulic fluid to said hydraulic cylinder (210).
- 15. A portable drilling rig according to any of claims 10 to 14, comprising an iron roughneck (320) disposed within said lower drilling mast (202).
- 16. A portable drilling rig according to any of claims 10 to 15, comprising a support structure (212) coupled to said lower drilling mast (202) and the base (110) when said lower drilling mast (202) is perpendicular to the base (110).
- 17. A method for erecting a drilling mast (100), the method comprising:

pivotaly coupling a lower drilling mast (202,402) to a base (110,500), wherein an upper drilling mast (204,404) is coupled to the lower drilling mast (202,402) by a hinge (206,408), wherein the lower drilling mast (202,402) is parallel to the base (110,500) and the upper drilling mast (204,404) is disposed between the lower drilling mast (202,402) and the base (110,500);

fixing the upper drilling mast (204,404) to the lower drilling mast (202,402) so as to prevent rotation about the hinge (206,408);

pivoting the upper drilling mast (204,404) and the lower drilling mast (202,402) to an elevated position;

unfixing the upper drilling mast (204,404) from the lower drilling mast (202,402) so as to allow rotation about the hinge (206,408);

pivoting the lower drilling mast (202,402) toward horizontal such the upper drilling mast (204,404) rotates about the hinge (206,408) until the upper drilling mast (204,404) is aligned with the lower drilling mast (202,402) in a substantially horizontal position;

fixing the upper drilling mast (204,404) to the lower drilling mast (202,402) so as to prevent rotation about the hinge (206,408); and,

pivoting the aligned upper and lower drilling masts (204,202;404,402) to a substantially vertical position.

- 18. A method according to claim 17, comprising fixing the lower drilling mast (202,402) to the base (110,500) once the aligned upper and lower drilling masts (204,202;404,402) are in the substantially vertical position.
- 19. A method according to claim 17 or claim 18, wherein the upper and lower drilling masts (204,202) are pivoted relative to the base (110) by a hydraulic cylinder (210) coupled to the base (110) and the lower drilling mast (202).
- 20. A method according to any of claims 17 to 19, wherein a latch (214) couples the upper drilling mast (204) to the lower drilling mast (202) so as to prevent rotation about the hinge (206).

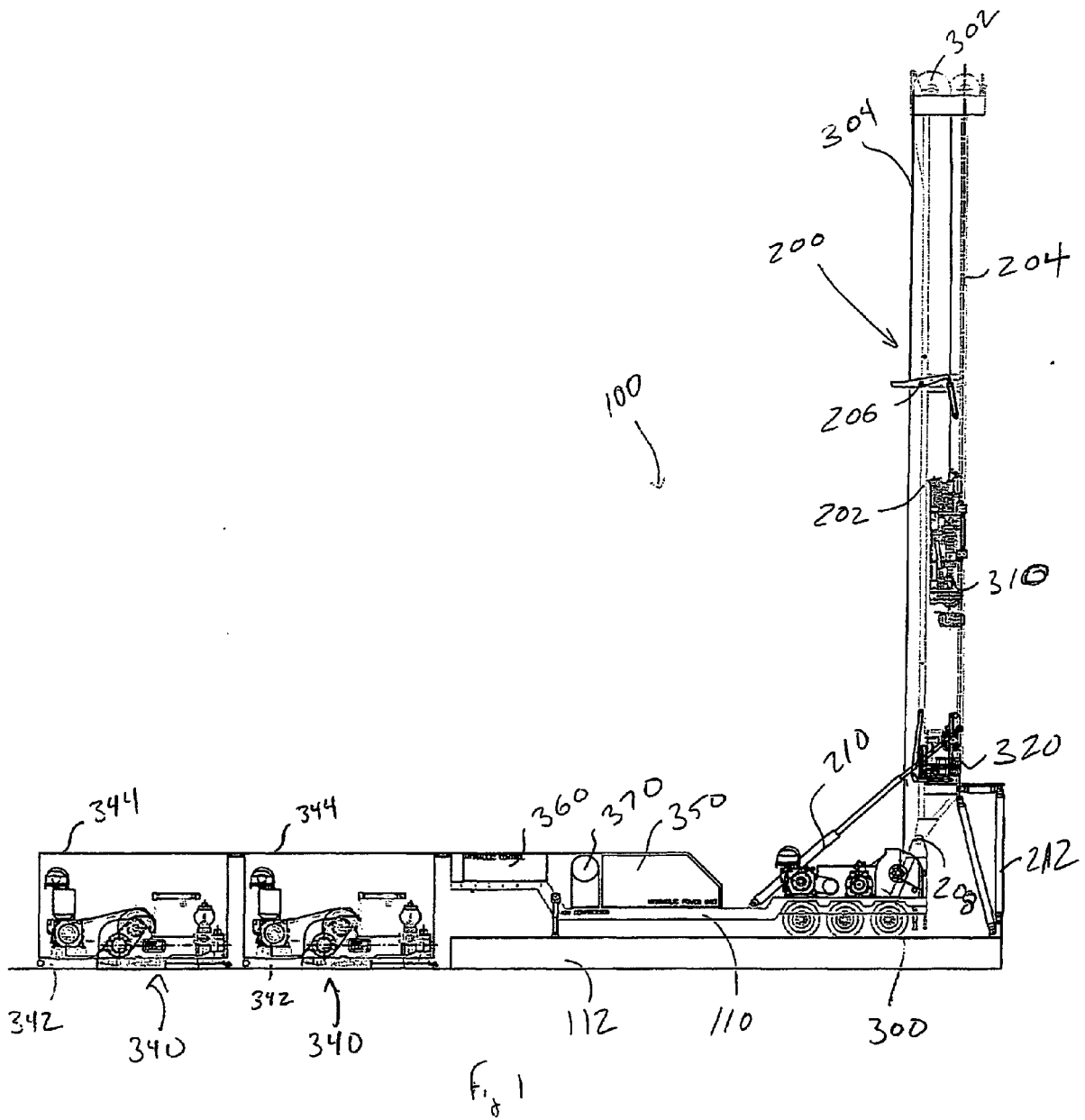

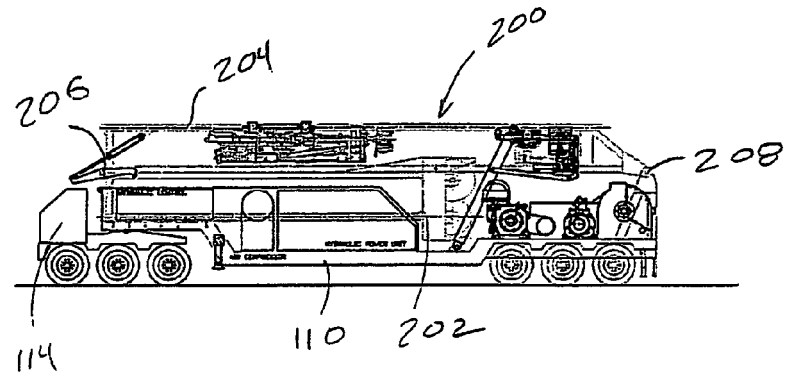

Fig. 2

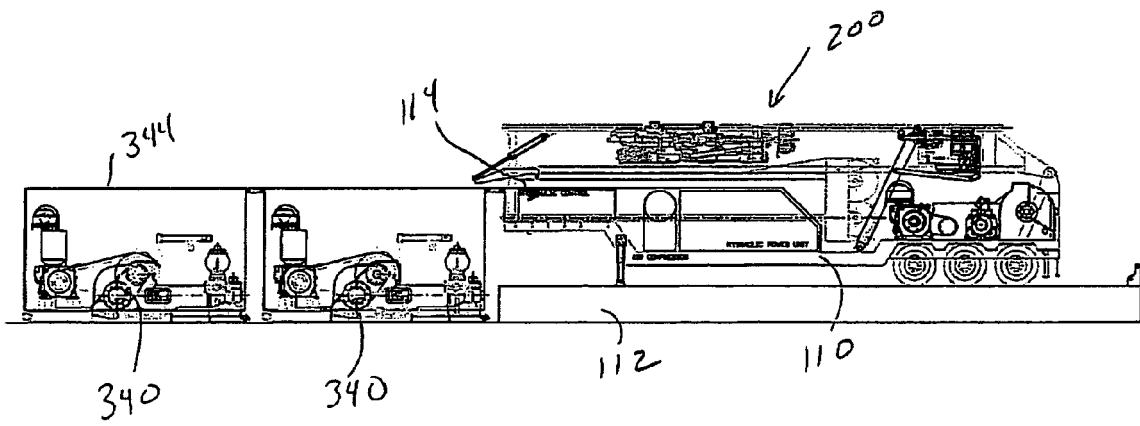

Fig 3

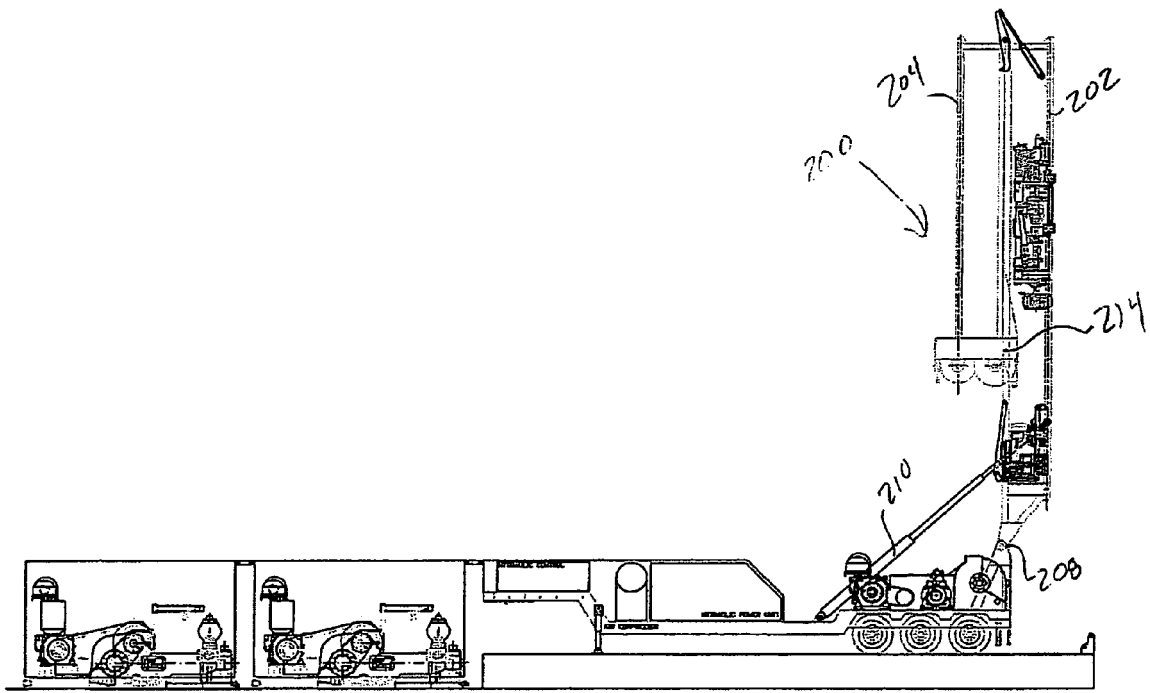

Fig 4

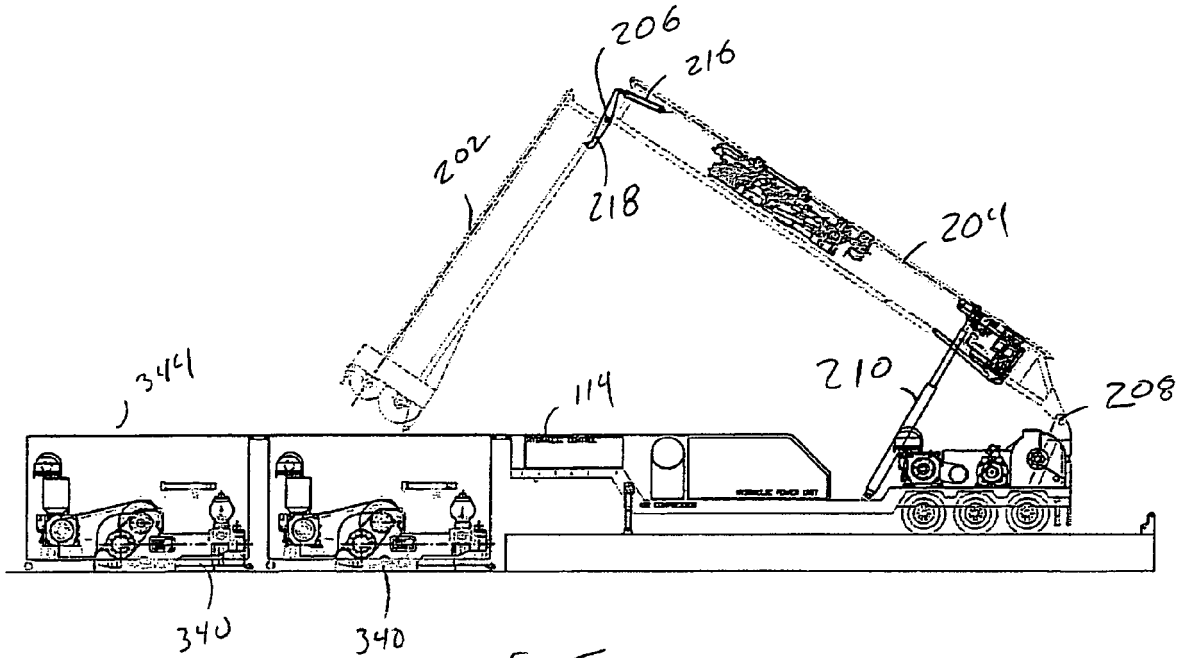

Fig 5

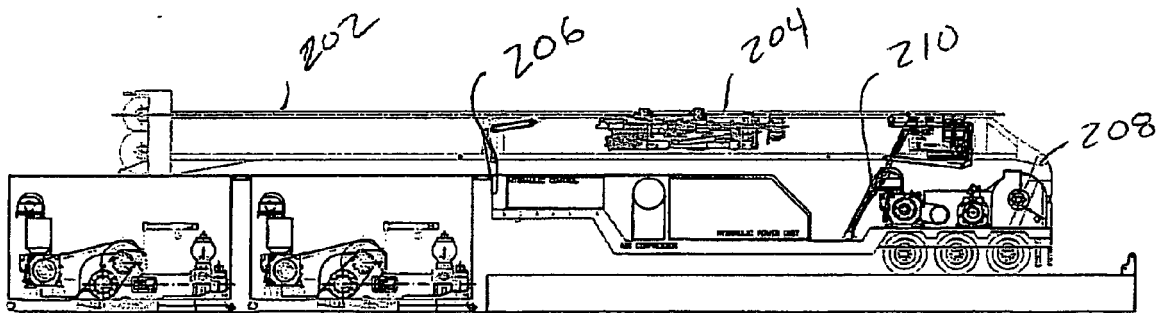

Fig 6

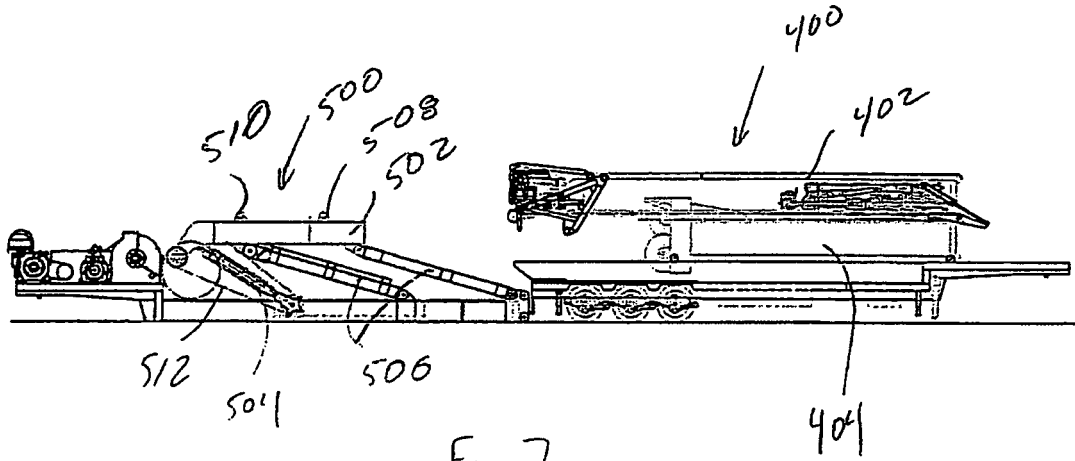

Fig. 7

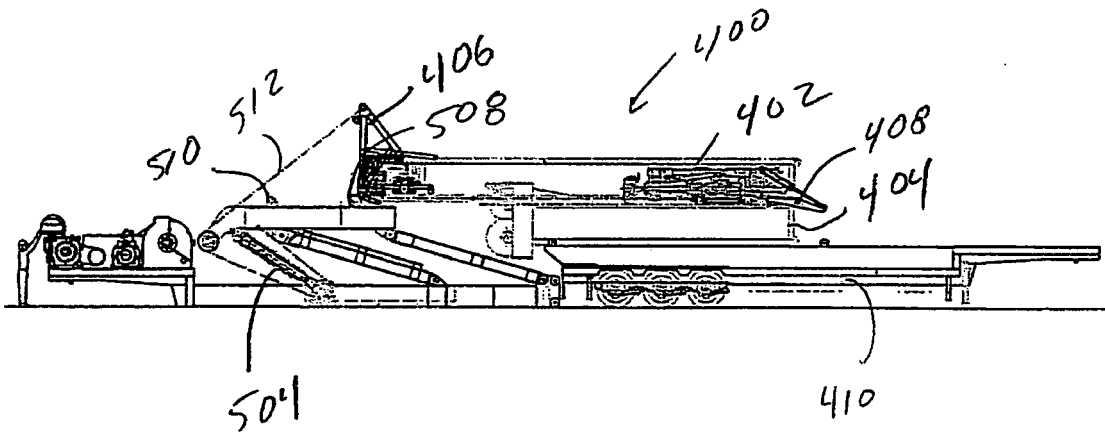

Fig. 8

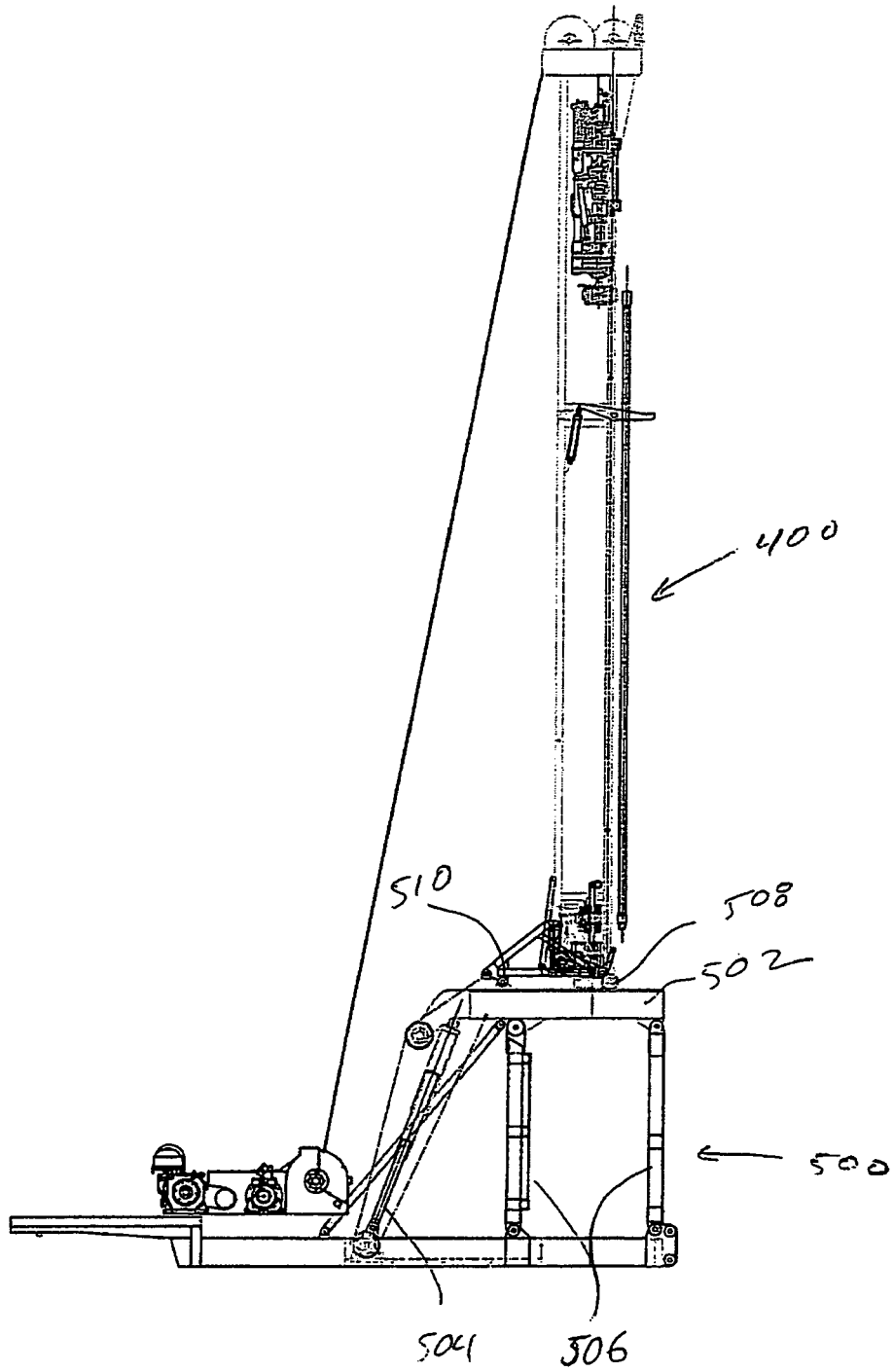

Fig 9