

(No Model.)

2 Sheets—Sheet 1.

O. STEPHENS. VALVE GEAR.

No. 489,836.

Patented Jan. 10, 1893.

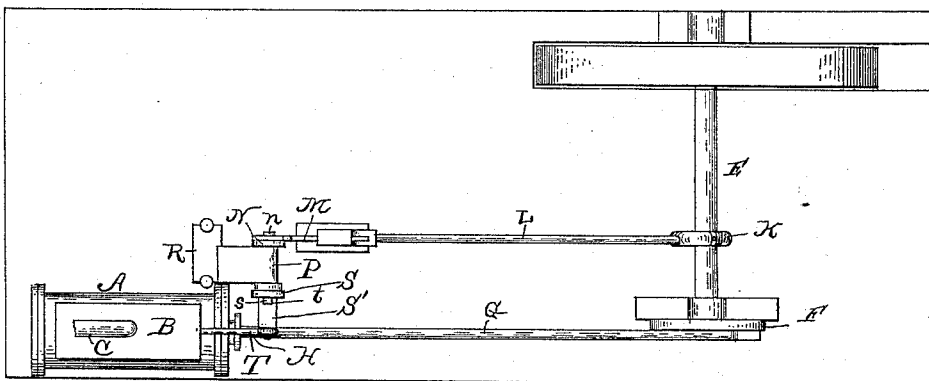
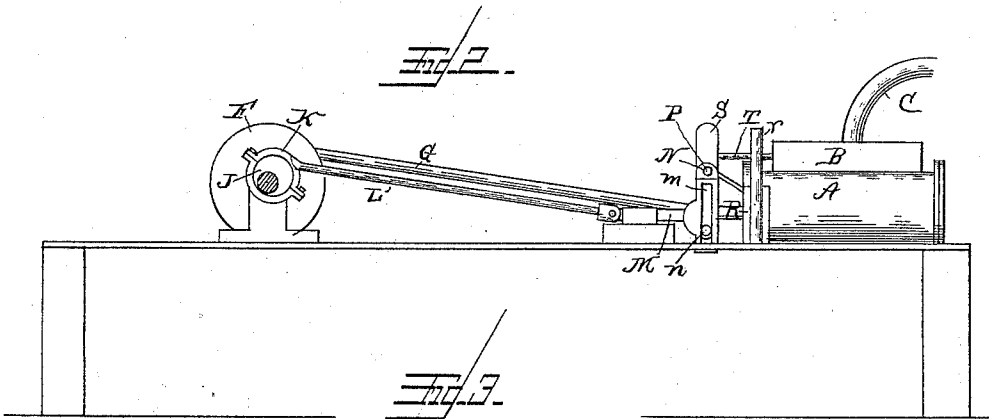
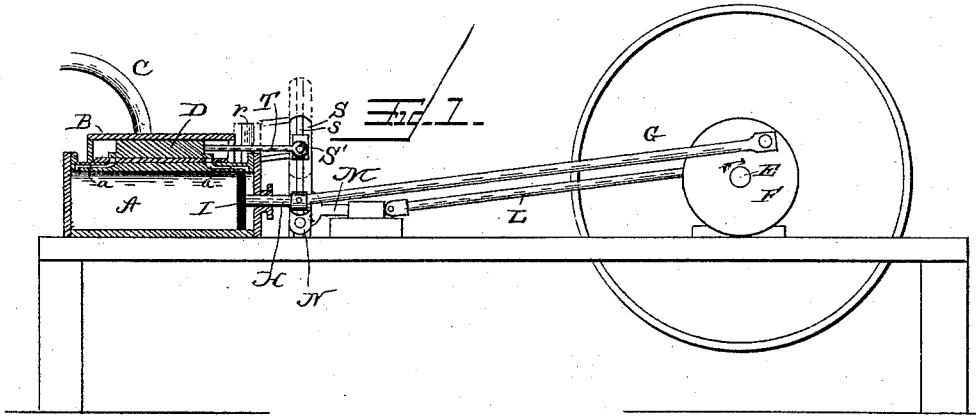

WITNESSES
C. S. Frye
G. J. Myers

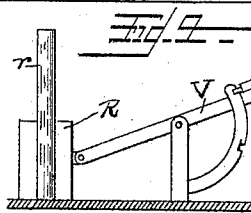

Omev Stephens
 INVENTOR
W. S. Fitzgerald & Co.
 Attorneys

UNITED STATES PATENT OFFICE.

OLNEY STEPHENS, OF ASTORIA, ILLINOIS.

VALVE-GEAR.

SPECIFICATION forming part of Letters Patent No. 489,836, dated January 10, 1893.

Application filed May 27, 1892. Serial No. 434,607. (No model.)

To all whom it may concern:

Be it known that I, OLNEY STEPHENS, a citizen of the United States, residing at Astoria, in the county of Fulton and State of Illinois, have invented certain new and useful Improvements in Valve-Gears for Steam-Engines; and I do hereby declare the following to be a full, clear, and exact description of the invention, such as will enable others skilled in the art to which it appertains to make and use the same.

My invention has relation to improvements in valve gear for steam engines and it consists in the peculiar construction, certain novel combinations and the adaptation of parts hereinafter described and particularly pointed out in the claims appended.

In the accompanying drawings:—Figure 1, is a side elevation partly in section of an engine embodying my invention. Fig. 2, is a similar view of the other side. Fig. 3, is a top plan view of the same, and; Fig. 4, is a detail elevation of the reversing lever. Fig. 5 illustrates a detail view showing the movable slide block and reversing mechanism.

In the said drawings similar letters designate corresponding parts in all the views, referring to which:—

A, indicates the cylinder of a steam engine, and B, indicates a valve chest which is fed by the steam pipe C, and is connected with the cylinder A, by the ports *a*, which are governed by the slide valve D, as better shown in Fig. 1, of the drawings.

Journalled in bearings at a suitable distance from the cylinder A, is the drive shaft E, which is provided at one end with a crank wheel F, to which is connected the pitman G, which is connected at its opposite end to the piston rod H, which in turn is connected to the piston I, in the cylinder A, as illustrated.

Fixedly mounted upon the shaft E, is an eccentric disk J, upon which is mounted the strap K, to which is fixedly connected an arm L. This arm L, preferably has its opposite end bi-furcated as shown for the pivotal connection of the forward end of the link M.

Formed in the vertically-disposed angular or T-branch at the inner end of the link M, is a vertical, transversely-disposed slot *m*, in which plays the lateral gudgeon *n*, upon the crank arm N, of the rock-shaft P, which shaft

is journalled in a suitable bearing carried by the vertically-movable slide block R, presently to be described. The shaft P, which is preferably disposed transversely as shown, is provided at its inner end with a fixed T-head or lever S, upon which is formed a rib *s*, which is designed and adapted to slide in the groove *t*, of the block S', and transmit motion to said block which is connected to the valve rod T, as shown.

Connected to the slide block R, which is mounted in suitable guide posts *r*, as illustrated, is the reversing lever V, through the medium of which the said block is raised and lowered to reverse the engine when desired.

In operation, when the slide block and its appurtenances are in the position illustrated by the full lines in Fig. 1, and the driveshaft is rotating in the direction indicated by the arrow, and it is desired to reverse the direction of such rotation, the said slide block and its appurtenances are raised to the position shown by dotted lines in the said figure, so that the lower end of the T-head or lever S, will engage the block S', of the valve rod T, whereby it will be seen that the movement of said rod and the valve carried thereby will be reversed and in consequence the reciprocatory movement of the piston will also be reversed for the purpose stated.

From the foregoing description it will be readily perceived that I have provided a valve gear of an exceedingly cheap, simple and durable construction through the medium of which an engine may be readily reversed; and by reason of my peculiar construction of gear, it will be further perceived that the objectionable necessity of employing two eccentric disks upon the drive shaft, together with connecting gear, is obviated.

From the construction described, it will be still further perceived that when the engine is on a dead center, the eccentric disk J, is at its fastest speed, and the T-head S, will move through the block S', of the valve rod T, without moving the valve which is set so as to be equalized over the ports. When the engine is moved off of the dead center the T-head S, will assume a vertically oblique position, and when the reverse lever is moved the valve will also be moved through the me-

dium of the said T-head S, and the block S'. In engines where lack is necessary the T-head S, will have to be longer and the eccentric J, will have to have more throw inasmuch as it will stand in the same position while on the forward or rear centers. Therefore, the engine will clear of steam while crossing centers and consequently will not be subjected to strain.

10 Although I have, in some respects, specifically described the construction and relative arrangement of the several elements of my improvements, yet I do not desire to be confined to the same, as such changes or modifications may be made as fairly fall within the scope of my invention.

15 Having thus described my invention, what I claim and desire to secure by Letters Patent is:—

20 1. In a steam engine, substantially as described, the combination with a steam cylinder, a valve chest communicating therewith, a slide valve mounted in said chest, a piston mounted in the cylinder, a drive shaft having a crank, mechanism connecting the piston and said crank and an eccentric disk fixedly mounted on the drive shaft; of an arm connected to a strap mounted on the eccentric disk, a link connected with said arm and having a vertical, transverse slot, the rock-shaft having the crank carrying the gudgeon engaging the slot in the link, the T-head or branch fixedly connected to the rock-shaft and the block carried by the valve rod and engaging the T-head; all substantially as and for the purpose set forth.

30 2. In a steam engine, substantially as described, the combination with a steam cylinder, a valve chest, a valve mounted in said chest, a piston mounted in the cylinder, a drive shaft having a crank, mechanism connecting the piston and said crank and an eccentric disk fixedly mounted on the drive shaft; of an arm connected to a strap mounted on the eccentric disk, a link connected with said arm and having a vertical, transverse slot, the rock-shaft journaled in a bearing carried by the slide block and having the crank carrying the gudgeon engaging the slot in the link, the T-head or branch fixedly connected to the rock-shaft, the block carried by the valve rod and engaging the T-head, and a suitable means for raising and lowering the slide block; substantially as and for the purpose set forth.

35 3. In a steam engine, substantially as described, the combination with the link having the vertical, transversely-disposed slot, the valve rod having the block S', and a suitable means for reciprocating the link; of the slide block, the rock-shaft journaled in a bearing carried by the slide block, and having a crank arm at one end provided with a gudgeon engaging the slot of the link, the T-head fixed on the opposite end of the rock-shaft and engaging the block S', of the valve rod, and a suitable means for raising and lowering the slide block; substantially as and for the purpose set forth.

der, a valve chest, a valve mounted in said chest, a piston mounted in the cylinder, a drive shaft having a crank, mechanism connecting the piston and said crank and an eccentric disk fixedly mounted on the drive shaft; of an arm connected to a strap mounted on the eccentric disk, a link connected with said arm and having a vertical, transverse slot, the vertically-movable slide-block, the rock-shaft journaled in a bearing carried by the slide block and having the crank carrying the gudgeon engaging the slot in the link, the T-head or branch fixedly connected to the rock-shaft, the block carried by the valve rod and engaging the T-head, and a suitable means for raising and lowering the slide block; substantially as and for the purpose set forth.

40 45 50 55 60 65

In testimony whereof I affix my signature in presence of two witnesses.

OLNEY STEPHENS.

Witnesses:
 JACOB DARLING,
 SAMUEL BOWLES.