

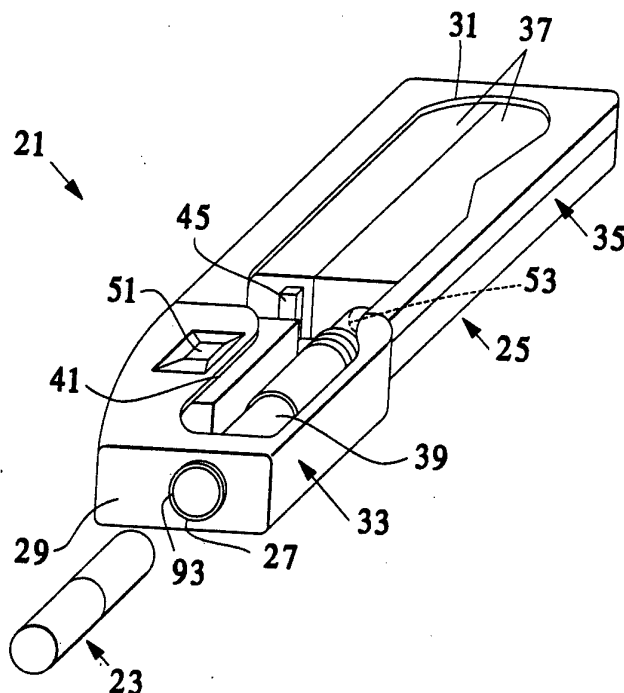

INTERNATIONAL APPLICATION PUBLISHED UNDER THE PATENT COOPERATION TREATY (PCT)

<p>(51) International Patent Classification ⁵ : A24F 47/00</p>	<p>A1</p>	<p>(11) International Publication Number: WO 94/06314 (43) International Publication Date: 31 March 1994 (31.03.94)</p>
<p>(21) International Application Number: PCT/US93/08457 (22) International Filing Date: 10 September 1993 (10.09.93) (30) Priority data: 943,504 11 September 1992 (11.09.92) US (71) Applicant: PHILIP MORRIS PRODUCTS INC. [US/US]; 3601 Commerce Road, Richmond, VA 23234 (US). (72) Inventors: COLLINS, Alfred, L. ; 2058 Hancock Road, Powhatan, VA 23139 (US). COUNTS, Mary, Ellen ; 4506 Cutshaw Avenue, Richmond, VA 23112 (US). DAS, Amitabh ; 7201 Decidedly Lane, Midlothian, VA 23112 (US). DEEVI, Seetharama, C. ; 8519 Whirlaway Drive, Midlothian, VA 23112 (US). FLEISCHHAUER, Grier, S. ; 1004 Lady Jean Court, Midlothian, VA 23113 (US). HAJALOGOL, Mohammad, R. ; 4509 Adelaide Avenue, Richmond, VA 23234 (US). HAYES, Patrick, H. ; 4540 Forrestral Road, Chester, VA 23831 (US). HIGGINS, Charles, T. ; 30 Glenbrooke Circle, Richmond, VA 23339 (US). HOUCK, Willie, G., Jr. ; 7753 Lake Forest Drive, Richmond, VA 23835 (US). KEEN, Billy, J., Jr. ; 12911 Blue Stack Court, Chesterfield, VA 23832 (US). LAROY, Bernard, C. ; 12821 Bailey Bridge Road, Richmond, VA 23112 (US). LEE, Robert, E., III ; 11802 Prince Regent Place, Richmond, VA 23233 (US). LILLY, A., Clifton, Jr. ; 9641 Waterfowl Flyway, Chesterfield, VA 23832 (US). LIPOWICZ, Peter, J. ; 4300 North Heritage Woods Road, Midlothian, VA 23112 (US). LOSEE, D., Bruce, Jr. ; 3912 Park Avenue, Richmond, VA 23221 (US). McCAFFERTY, Hugh, J. ; 2811 Bosham Lane, Midlothian, VA 23113 (US). MISER, Donald, E. ; 6912 Velvet Antler Drive, Midlothian, VA 23112 (US).</p>		<p>NICHOLS, Constance, H. ; 9608 Summercliff Court, Chesterfield, VA 23832 (US). RAYMOND, Wynn, R. ; 6401 Wilton Road, Richmond, VA 23832 (US). RIPLEY, Robert, L. ; 8140 Ammonette Drive, Richmond, VA 23235 (US). RITT, Renzer, R., Sr. ; 1517 Chevelle Drive, Richmond, VA 23235 (US). SCOTT, G., Robert ; 13381 Drakewood Road, Midlothian, VA 23113 (US). SPRINKEL, F., Murphy ; Route 4, Box 347, Glen Allen, VA 23060 (US). STEVENS, William, H. ; 1959 Albion Road, Midlothian, VA 23113 (US). SUBBIAH, Mantharam ; 2430 Olde Queen Terrace, Midlothian, VA 23113 (US). UTSCH, Francis, V. ; 13000 Robious Road, Midlothian, VA 23113 (US). WATKINS, Michael, L. ; 3318 Grove Avenue, Chester, VA 23831 (US). WRENN, Susan, E. ; 12130 Ivy Mill Road, Chesterfield, Virginia 23832 (US). (74) Agents: MAGNONE, Joseph, R. et al.; Burns, Doane, Swecker & Mathis, George Mason Building, Washington and Prince Streets, P.O. Box 1404, Alexandria, VA 22313-1404 (US). (81) Designated States: AU, BG, BR, BY, CA, CZ, FI, HU, JP, KP, KR, KZ, LV, NO, NZ, PL, RO, RU, SK, UA, UZ, VN, European patent (BE, FR, GR, IE, IT, MC), OAPI patent (BF, BJ, CF, CG, CI, CM, GA, GN, ML, MR, NE, SN, TD, TG). Published <i>With international search report.</i> <i>Before the expiration of the time limit for amending the claims and to be republished in the event of the receipt of amendments.</i></p>

(54) Title: ELECTRICAL SMOKING SYSTEM FOR DELIVERING FLAVORS AND METHOD FOR MAKING SAME



(57) Abstract

A smoking system (21) is provided in which a replaceable cigarette (23) containing tobacco flavor material is electrically heated by a set of electrical heater elements contained within a lighter (25) to evolve tobacco flavors or other components in vapor or aerosol form for delivery to a smoker. The cigarette (23) and lighter (25) are adapted to provide air flow patterns through the smoking system such that air flows transversely into the cigarette (23). Such patterns improve aerosol and flavor delivery to the smoker and reduce the condensation of residual heater-region vapor/aerosol in the smoking system.

FOR THE PURPOSES OF INFORMATION ONLY

Codes used to identify States party to the PCT on the front pages of pamphlets publishing international applications under the PCT.

AT	Austria	FR	France	MR	Mauritania
AU	Australia	GA	Gabon	MW	Malawi
BB	Barbados	GB	United Kingdom	NE	Niger
BE	Belgium	GN	Guinea	NL	Netherlands
BF	Burkina Faso	GR	Greece	NO	Norway
BG	Bulgaria	HU	Hungary	NZ	New Zealand
BJ	Benin	IE	Ireland	PL	Poland
BR	Brazil	IT	Italy	PT	Portugal
BY	Belarus	JP	Japan	RO	Romania
CA	Canada	KP	Democratic People's Republic of Korea	RU	Russian Federation
CF	Central African Republic			SD	Sudan
CG	Congo	KR	Republic of Korea	SE	Sweden
CH	Switzerland	KZ	Kazakhstan	SI	Slovenia
CI	Côte d'Ivoire	LI	Liechtenstein	SK	Slovak Republic
CM	Cameroon	LK	Sri Lanka	SN	Senegal
CN	China	LU	Luxembourg	TD	Chad
CS	Czechoslovakia	LV	Latvia	TG	Togo
CZ	Czech Republic	MC	Monaco	UA	Ukraine
DE	Germany	MG	Madagascar	US	United States of America
DK	Denmark	ML	Mali	UZ	Uzbekistan
ES	Spain	MN	Mongolia	VN	Viet Nam
FI	Finland				

**ELECTRICAL SMOKING SYSTEM FOR DELIVERING
FLAVORS AND METHOD FOR MAKING SAME**

Cross-Reference to Related Applications

This application is a continuation-in-part of copending, commonly-assigned United States Patent Application Serial No. 07/666,926, filed March 11, 1991, now
5 abandoned in favor of file-wrapper continuation application Serial No. 08/012,799, filed February 2, 1993, which is hereby incorporated in its entirety.

Background of the Invention

This invention relates to smoking systems in which
10 cigarettes are used with lighters, and methods for making the same.

An electrical smoking article is described in commonly-assigned United States Patent No. 5,060,671, which is hereby incorporated by reference in its entirety. That
15 patent describes a smoking article which is provided with a disposable set of electrical heating elements. A charge of tobacco flavor medium containing, for example, tobacco or tobacco-derived material is deposited on each of the heating elements. The disposable heater/flavor unit is mated to a
20 source of electrical energy such as a battery or capacitor, as well as to control circuitry to actuate the heating elements in response to a puff by a smoker on the article or in response to the depression of a manual switch. The circuitry is designed so that at least one, but less than
25 all of the heating elements are actuated for any one puff, and so that a predetermined number of puffs, each containing a pre-measured amount of tobacco flavor substance, e.g., an aerosol containing tobacco flavors or a flavored tobacco response, is delivered to the smoker. The circuitry also
30 preferably prevents the actuation of any particular heater more than once, to prevent overheating of the tobacco flavor medium thereon.

- 2 -

With such articles, the heater is thrown away with the spent remainder of tobacco material. Also, the electrical connections between the heaters and the battery must be able to endure repeated release and reconnection as 5 flavor units are replaced.

In copending, commonly-assigned United States Patent Application Serial No. 07/666,926, filed March 11, 1991, now abandoned in favor of Continuing Application Serial No. 08/012,799, filed February 2, 1993, an electrical 10 smoking article is disclosed that has reusable heating elements and a disposable portion for tobacco flavor generation. The disposable portion preferably includes a flavor segment and a filter segment, attached by a tipping paper or other fastening arrangement. Certain operational 15 difficulties are, however, associated with reusable heating elements, particularly in that residual aerosol tends to settle and condense on the heating elements and other permanent structural components of the article.

In light of the above, it is therefore desirable 20 to be able to provide an improved smoking system in which the heating elements of the lighter are reusable.

It is also desirable to be able to provide such a system in which condensation of aerosol onto the heating elements and other structural components of the lighter is 25 minimized.

It is further desirable to provide a smoking article which is easier to manufacture.

It is still further desirable to provide a smoking article which provides improved flavor delivery to the 30 smoker.

Summary of the Invention

Accordingly, a primary object of the present invention is to provide a novel smoking system which provides advantages over prior systems.

- 3 -

Another object of the present invention is to provide improved flavor delivery from a smoking system in which cigarettes are used with lighters.

It is also an object of this invention to provide
5 a smoking system in which the heating elements of a lighter are reusable, and of which the volume of disposable portions is minimized.

It is also an object of this invention to provide
10 a system in which condensation of aerosol onto heating elements and other structural components of a lighter is minimized.

It is a further object of this invention to provide a smoking article and manufacturing processes for making the same that are easier and cost effective, even at
15 state-of-the-art mass production speeds.

It is a still further object of this invention to provide improved aerosol and flavor delivery to the smoker.

In accordance with one aspect of the present invention, a cigarette for use in a smoking system for
20 delivering a flavored tobacco response to a smoker, the system including heating means, is provided. The cigarette includes a carrier having first and second ends spaced apart in a longitudinal direction and having first and second surfaces. The first surface defines a cavity between the
25 first and second ends, and the second surface includes an area for being disposed adjacent heating means. Tobacco flavor material is disposed on the first surface of the carrier. The tobacco flavor material generates the flavored tobacco response in the cavity for delivery to a smoker when
30 the tobacco flavor material is heated by the heating means. The carrier and the tobacco flavor material allow transverse air flow into the cavity.

In accordance with another aspect of the present invention, a lighter for use in combination with a removable
35 cigarette in a smoking system that delivers a flavored tobacco response to a smoker is provided. The lighter includes a heater fixture for receiving, through a first

- 4 -

end, a removable cigarette. The heater fixture has means for providing a transverse flow of air to at least a portion of the cigarette. A plurality of electrical heater elements are disposed in the heater fixture. Each of the heater
5 elements has a surface for being disposed adjacent a surface of the portion of the cigarette to which the transverse flow of air is provided. Means are provided for activating one or more of the plurality of electrical heating means such that a predetermined quantity of flavored tobacco response
10 is generated in the cigarette. The transverse flow of air is generated when a smoker draws on a cigarette inserted in the lighter.

In accordance with another aspect of the present invention, a smoking system for delivering a flavored
15 tobacco response to a smoker is provided. The system includes a removable cigarette, a lighter, and, means for individually activating the plurality of electrical heating means such that a predetermined quantity of flavored tobacco response is generated in a cavity in the cigarette.

20 In accordance with yet another aspect of the present invention, a heater element for use in a smoking system for delivering a flavored tobacco response to a smoker is provided. The heater element includes a first end, a second end, and a plurality of curved regions between
25 the first and second ends for increasing electrical resistance of the heater element. The heater element is formed from resistive material having first and second surfaces substantially oriented in a plane and having an overall length L , overall width W , and thickness T . The
30 effective electrical length of the heater element is greater than the length L and the effective electrical cross-sectional area of the heater element is less than the product of W and T .

In accordance with still another aspect of the
35 present invention, a method for manufacturing an integrated heater assembly for use in a smoking system for delivering a flavored tobacco response to a smoker is described.

- 5 -

According to the method, a sheet of resistive material is cut to form a plurality of heater elements connected to one another at at least one end. The sheet is formed into a cylindrical shape.

5 Brief Description of the Drawings

The present invention can be further understood with reference to the following description in conjunction with the appended drawings, wherein the same elements are provided with the same reference numerals. In the drawings:

10 FIG. 1 is a schematic perspective view of a smoking system according to an embodiment of the present invention;

FIG. 2 is a partially broken, schematic perspective view of a smoking system according to an
15 embodiment of the present invention;

FIG. 3A is a side, cross-sectional view of a heater fixture according to an embodiment of the present invention;

20 FIG. 3B is an end view of taken at section 3B-3B of FIG. 3A;

FIG. 4A is a schematic perspective view of a cigarette according to an embodiment of the present invention;

25 FIG. 4B is a side cross-sectional view taken at section 4B-4B of FIG. 4A;

FIG. 5 is a schematic assembly view of a heater fixture according to another embodiment of the present invention;

30 FIG. 6 is a perspective view of a heater assembly according to an embodiment of the present invention;

FIG. 7 is an outline of a heater assembly according to an embodiment of the present invention;

35 FIG. 8 is a perspective view of a portion of a heater element according to an embodiment of the present invention;

- 6 -

FIG. 9 is a perspective view of a pin assembly according to an embodiment of the present invention;

FIG. 10A is a schematic, side cross-sectional view of a spacer according to an embodiment of the present invention;

FIG. 10B is a schematic view taken at section 10B-10B of FIG. 10A;

FIG. 10C is a schematic view taken at section 10C-10C of FIG. 10A;

FIG. 11A is a schematic, side cross-sectional view of a base according to an embodiment of the present invention;

FIG. 11B is a schematic view taken at section 11B-11B of FIG. 11A;

FIG. 11C is a schematic view taken at section 11C-11C of FIG. 11A;

FIG. 12A is a schematic, perspective view of a combined spacer base member according to an embodiment of the present invention;

FIG. 12B is a schematic, side cross-sectional view taken at section 12B-12B of FIG. 12A;

FIG. 12C is a schematic view taken at section 12C-12C of FIG. 12A;

FIG. 12D is a schematic view taken at section 12D-12D of FIG. 12A;

FIG. 13 is an end view of a ring according to an embodiment of the present invention;

FIG. 14A is a schematic, perspective view of a cap according to an embodiment of the present invention;

FIG. 14B is a schematic, side cross-sectional view taken at section 14B-14B of FIG. 14A;

FIG. 14C is a schematic view taken at section 14C-14C of FIG. 14A;

FIG. 14D is a schematic view taken at section 14D-14D of FIG. 14A;

FIG. 15A is a schematic side view of a heater sleeve according to an embodiment of the present invention;

- 7 -

FIG. 15B is an end view taken at section 15B-15B of FIG. 15A;

FIGS. 16 and 17 are schematic side cross-sectional views of portions of a smoking system showing air flow paths in the smoking system;

FIG. 18 is a schematic circuit diagram showing circuitry according to an embodiment of the invention;

FIG. 19 is a schematic, cross-sectional side view of a smoking system according to a further embodiment of the present invention;

FIG. 20 is a schematic, cross-sectional side view of a heater fixture according to a further embodiment of the present invention;

FIG. 21 is a schematic perspective view of an apparatus for manufacturing a center portion of a disposable cigarette of the smoking system of FIG. 19;

FIG. 22 is a schematic, cross-sectional side view of a "peripheral draw" embodiment of a smoking system according to the present invention;

FIG. 23 is a schematic circuit diagram showing circuitry according to a further embodiment of the invention; and

FIG. 24 is a schematic circuit diagram of a timing network of the control circuit of FIG. 23.

25 Detailed Description

A smoking system 21 according to the present invention is seen with reference to FIGS. 1 and 2. The smoking system 21 includes a cigarette 23 and a reusable lighter 25. The cigarette 23 is adapted to be inserted in and removed from an orifice 27 at a front end 29 of the lighter 25. The smoking system 21 is used in much the same fashion as a conventional cigarette. The cigarette 23 is disposed of after one or more puff cycles. The lighter 25 is preferably disposed of after a greater number of puff cycles as the cigarette 23.

- 8 -

The lighter 25 includes a housing 31 and has front and rear portions 33 and 35. A power source 37 for supplying energy to heating elements for heating the cigarette 23 is preferably disposed in the rear portion 35 of the lighter 25. The rear portion 35 is preferably adapted to be easily opened and closed, such as with screws or with snap-fit components, to facilitate replacement of the power source 37. The front portion 33 preferably houses heating elements and circuitry in electrical communication with the power source 37 in the rear portion 35. The front portion 33 is preferably easily joined to the rear portion 35, such as with a dovetail joint or by a socket fit. The housing 31 is preferably made from a hard, heat-resistant material. Preferred materials include metal-based or, more preferably, polymer-based materials. The housing 31 is preferably adapted to fit comfortably in the hand of a smoker and, in a presently preferred embodiment, has overall dimensions of 10.7 cm by 3.8 cm by 1.5 cm.

The power source 37 is sized to provide sufficient power for heating elements that heat the cigarette 23. The power source 37 is preferably replaceable and rechargeable and may include devices such as a capacitor or, more preferably, a battery. In a presently preferred embodiment, the power source is a replaceable, rechargeable battery (actually four nickel cadmium battery cells connected in series) with a total, non-loaded voltage of approximately 4.8 to 5.6 volts. The characteristics required of the power source 37 are, however, selected in view of the characteristics of other components in the smoking system 21, particularly the characteristics of the heating elements. U.S. Patent No. 5,144,962 describes several forms of power sources useful in connection with the smoking system of the present invention, such as rechargeable battery power sources and quick-discharging capacitor power sources that are charged by batteries, and is hereby incorporated by reference.

- 9 -

A substantially cylindrical heating fixture 39 for heating the cigarette 23, and, preferably, for holding the cigarette in place relative to the lighter 25, and electrical control circuitry 41 for delivering a
5 predetermined amount of energy from the power source 37 to heating elements (not seen in FIGS. 1 and 2) of the heating fixture are preferably disposed in the front 33 of the lighter. In the presently preferred embodiment, the heating fixture 39 includes eight radially spaced heating elements
10 43, seen in FIG. 3A, that are individually energized by the power source 37 under the control of the circuitry 41 to heat eight areas around the periphery of the cigarette 23 to develop eight puffs of a flavored tobacco response. While other numbers of heating elements 43 may be provided, eight
15 heater elements are preferred, at least because there are nominally eight puffs on a conventional cigarette and because eight heater elements lend themselves to electrical control with binary devices.

The circuitry 41 is preferably activated by a
20 puff-actuated sensor 45, seen in FIG. 2, that is sensitive either to pressure changes or air flow changes that occur when a smoker draws on the cigarette 23. The puff-actuated sensor 45 is preferably disposed in the front 33 of the lighter 25 and communicates with a space inside the heater
25 fixture 39 and near the cigarette 23 through a passageway 47 extending through a spacer 49 and a base 50 of the heater fixture and, if desired, a puff sensor tube (not shown). A puff-actuated sensor 45 suitable for use in the smoking system 21 is described in U.S. Patent No. 5,060,671, the
30 disclosure of which is incorporated by reference, and is in the form of a Model 163PC01D35 silicon sensor, manufactured by the MicroSwitch division of Honeywell, Inc., Freeport, Ill., which activates an appropriate one of the heater elements 43 as a result of a change in pressure when a
35 smoker draws on the cigarette 23. Flow sensing devices, such as those using hot-wire anemometry principles, have also been successfully demonstrated to be useful for

- 10 -

activating an appropriate one of the heater elements 43 upon detection of a change in air flow.

An indicator 51 is preferably provided on the exterior of the lighter 25, preferably on the front 33, to indicate the number of puffs remaining on a cigarette 23 inserted in the lighter. The indicator 51 preferably includes a seven-segment liquid crystal display. In the presently preferred embodiment, the indicator 51 displays the digit "8" when a light beam emitted by a light sensor 53, seen in FIG. 2, is reflected off of the front of a newly inserted cigarette 23 and detected by the light sensor. The light sensor 53 is preferably mounted in an opening 55 in the spacer 49 and the base 50 of the heater fixture 39, seen, for example, in FIG. 3A. The light sensor 53 provides a signal to the circuitry 41 which, in turn, provides a signal to the indicator 51. The display of the digit "8" on the indicator 51 reflects that the preferred eight puffs provided on each cigarette 23 are available, i.e., none of the heater elements 43 have been activated to heat the new cigarette. After the cigarette 23 is fully smoked, the indicator displays the digit "0". When the cigarette 23 is removed from the lighter 25, the light sensor 53 does not detect the presence of a cigarette 23 and the indicator 51 is turned off. The light sensor 53 is modulated so that it does not constantly emit a light beam and provide an unnecessary drain on the power source 37. A presently preferred light sensor 53 suitable for use with the smoking system 21 is a Type OPR5005 Light Sensor, manufactured by OPTEK Technology, Inc., 1215 West Crosby Road, Carrollton, Texas 75006.

As one of several possible alternatives to using the above-noted light sensor 53, a mechanical switch (not shown) may be provided to detect the presence or absence of a cigarette 23 and a reset button (not shown) may be provided for resetting the circuitry 41 when a new cigarette is inserted in the lighter 25, e.g., to cause the indicator 51 to display the digit "8", etc. Power sources, circuitry,

- 11 -

puff-actuated sensors, and indicators useful with the smoking system 21 of the present invention are described in U.S. Patent No. 5,060,671, which is incorporated by reference. The passageway 47 and the opening 55 in the spacer 49 and the heater fixture base 50 are preferably air-tight during smoking.

A presently preferred cigarette 23 for use with the smoking system 21 is seen in detail in FIGS. 4A and 4B, although the cigarette may be in any desired form capable of generating a flavored tobacco response for delivery to a smoker when the cigarette is heated by the heating elements 43. The cigarette 23 includes a tobacco web 57 formed of a carrier or plenum 59 which supports tobacco flavor material 61, preferably including tobacco. The tobacco web 57 is wrapped around and supported by a cylindrical back-flow filter 63 at one end and a cylindrical first free-flow filter 65 at an opposite end. The first free-flow filter 65 is preferably an "open-tube" type filter having a longitudinal passage 67 extending through the center of the first free-flow filter and, hence, provides a low resistance to draw or free flow.

If desired, cigarette overwrap paper 69 is wrapped around the tobacco web 57. Types of paper useful as the overwrap paper 69 include a low basis weight paper, preferably a paper with a tobacco flavor coating, or a tobacco-based paper to enhance the tobacco flavor of the flavored tobacco response. A concentrated extract liquor in full or diluted strength may be coated on the overwrap paper 69. The overwrap paper 69 preferably possesses a minimal base weight and caliper while providing sufficient tensile strength for machine processes. Presently preferred characteristics of a tobacco-based paper include a basis weight (at 60% relative humidity) of between 20-25 grams/m², minimum permeability of 0-25 CORESTA (defined as the amount of air, measured in cubic centimeters, that passes through one square centimeter of material, e.g., a paper sheet, in one minute at a pressure drop of 1.0 kilopascal), tensile

- 12 -

strength \geq 2000 grams/27 mm width (1 in/min), caliper 1.3 - 1.5 mils, CaCO_3 content \leq 5%, citrate 0%. Materials for forming the overwrap paper 69 preferably include \geq 75% tobacco-based sheet (non-cigar, flue- or flue-/air-cured mix
5 filler and bright stem). Flax fiber in amounts no greater than that necessary to obtain adequate tensile strength may be added. The overwrap paper 69 can also be conventional flax fiber paper of basis weight 15-20 g/m² or such paper with an extract coating. Binder in the form of citrus
10 pectin may be added in amounts less than or equal to 1%. Glycerin in amounts no greater than necessary to obtain paper stiffness similar to that of conventional cigarette paper may be added.

The cigarette 23 also preferably includes a
15 cylindrical mouthpiece filter 71, which is preferably a conventional RTD-type (Resistance To Draw) filter, and a cylindrical second free-flow filter 73. The mouthpiece filter 71 and the second free-flow filter are secured to one another by tipping paper 75. The tipping paper 75 extends
20 past an end of the second free-flow filter 73 and is attached to the overwrap paper 69 to secure an end of the first free-flow filter 65 in position adjacent an end of the second free-flow filter. Like the first free-flow filter 65, the second free-flow filter 73 is preferably formed with
25 a longitudinal passage 77 extending through its center. The back-flow filter 63 and the first free-flow filter 65 define, with the tobacco web 57, a cavity 79 within the cigarette 23.

It is preferred that the inside diameter of the
30 longitudinal passage 77 of the second free-flow filter 73 be larger than the inside diameter of the longitudinal passage 67 of the first free-flow filter 65. Presently preferred inside diameters for the longitudinal passage 67 are between 1-4 mm and for the longitudinal passage 77 are between 2-6
35 mm. It has been observed that the different inside diameters of the passages 67 and 77 facilitates development of a desirable mixing or turbulence between the aerosol

- 13 -

developed from the heated tobacco flavor material and air drawn in from outside the cigarette 23 during drawing on the cigarette, resulting in an improved flavored tobacco response and facilitating exposure of more of an end of the mouthpiece filter 71 to the mixed aerosol. The flavored tobacco response developed by heating the tobacco flavor material 61 is understood to be primarily in a vapor phase in the cavity 79 and to turn into a visible aerosol upon mixing in the passage 77. In addition to the above-described first free-flow filter 65 having a longitudinal passage 67, other arrangements capable of generating the desired mixing of the vapor phase flavored tobacco response with introduced air include those in which a first free-flow filter is provided in the form of a filter having a multitude of small orifices, i.e., the first free-flow filter may be in the form of a honeycomb or a metal plate having multiple holes formed therein.

Air is preferably drawn into the cigarette 23 predominantly through the tobacco web 57 and the overwrap paper 69, in a transverse or radial path, and not through the back-flow filter 63 in a longitudinal path. As explained below, however, it is desirable to permit air flow through the back-flow filter during a first puff on the cigarette to lower the RTD. It is presently understood that drawing air into the cigarette 23 longitudinally tends to result in the aerosol developed by heating the tobacco web 57 with the heater elements 43 arranged radially around the tobacco web not being properly removed from the cavity 79. It is presently preferred to produce a flavored tobacco response as a function almost entirely of the makeup of the tobacco web 57 and the energy level of the heater elements 43. Accordingly, the portion of the air flow through the cigarette resulting from longitudinal flow through the back-flow filter 63 is preferably minimal during smoking, except during the first puff. Further, the back-flow filter 63 preferably minimizes the flow of aerosol in a backward direction out of the cavity 79 after heating of the tobacco

- 14 -

flavor material 61, so that the potential for damage to components of the lighter 25 from aerosol flowing backward from the cigarette 23 is minimized.

The carrier or plenum 59 which supports the tobacco flavor material 61 provides a separation between the heating elements 43 and the flavor material, transfers heat generated by the heater elements to the flavor material, and maintains cohesion of the cigarette after smoking. Preferred carriers 59 include those composed of a non-woven carbon fiber mat, preferred because of its thermal stability. Such carriers are discussed in greater detail in copending commonly-assigned United States Patent Application Serial No. 07/943,747, filed September 11, 1992, which is incorporated by reference. Such mats should preferably have a thickness between about 0.05 mm and about 0.11 mm and be composed of nonwoven carbon fibers (having a basis weight in the range of from about 6 g/m² to about 12 g/m² with fiber diameters between about 7 μm and about 30 μm). The lengths of the fibers should allow the mat to withstand the tensile stresses encountered during processing. Preferably, the mats should include a binder which is suitable for use in electric smoking articles (i.e., having acceptable subjective properties).

Other carriers 59 include low mass, open mesh metallic screens or perforated metallic foils. For example, a screen having a mass in the range from about 5 g/m² to about 15 g/m² and having wire diameters in the range from about 0.038 mm (about 1.5 mils) to about 0.076 mm (about 3.0 mils) is used. Another embodiment of the screen is formed of a 0.0064 mm (about 0.25 mil)-thick foil (e.g., aluminum) having perforations with diameters in the range from about 0.3 mm to about 0.5 mm, to reduce the mass of the foil by about 30 percent to about 50 percent, respectively. Preferably, the perforation pattern of such a foil is staggered or discontinuous (i.e., not in straight arrangement) to reduce the lateral conduction of heat away from the tobacco flavor material 61.

- 15 -

Such metallic screens and foils are incorporated into a cigarette 23 in a variety of ways including, for example, (1) casting a tobacco flavor slurry on a belt and overlaying the screen or foil carrier on the wet slurry
5 prior to drying, and (2) laminating the screen or foil carrier to a tobacco flavor base sheet or mat with a suitable adhesive. Because of the possibility of electrical shorting in or between the heater elements 43 where a metallic carrier is used, such carriers should generally not
10 be in direct contact with the heating elements. Where a metallic carrier is used, suitable binders and low basis weight paper, such as the overwrap paper 69, are preferably used to provide electrical insulation between the metallic carrier 59 and the electrical heater elements 43.

15 A presently preferred tobacco web 57 is formed using a paper making-type process. In this process, tobacco strip is washed with water. The solubles are used in a later coating step. The remaining (extracted) tobacco fiber is used in the construction of a base mat. Carbon fibers
20 are dispersed in water and sodium alginate is added. Any other hydrocolloid which does not interfere with the flavored tobacco response, is water soluble, and has a suitable molecular weight to impart strength to the tobacco web 57 may be added in lieu of sodium alginate. The
25 dispersion is mixed with the slurry of extracted tobacco fibers and optional flavors. The resultant mixture is wet-laid onto a fourdriner wire and the web is passed along the remainder of a traditional paper making machine to form a base web. The solubles removed by washing the tobacco strip
30 are coated onto one side of the base web, preferably by a standard reverse roll coater located after a drum or Yankee dryer. The tobacco solubles/tobacco dust or particulate ratio is preferably varied between a 1:1 and a 20:1 ratio. The slurry may also be cast or extruded onto the base mat.
35 Alternatively, the coating step is produced off-line. During or after the coating step, flavors that are conventional in the cigarette industry are added. Pectin or

- 16 -

another hydrocolloid is added, preferably in a range of between 0.1 to 2.0%, to improve the coatability of the slurry.

Whichever type of carrier 59 is used, tobacco
5 flavor material 61 which is disposed on the inner surface of the carrier liberates flavors when heated and is able to adhere to the surface of the carrier. Such materials include continuous sheets, foams, gels, dried slurries, or dried spray-deposited slurries, which preferably, although
10 not necessarily, contain tobacco or tobacco-derived materials, and which are more fully discussed in the above-incorporated United States Patent Application Serial No. 07/943,747.

Preferably, a humectant, such as glycerin or
15 propylene glycol, is added to the tobacco web 57 during processing in amounts equalling between 0.5% and 10% of humectant by the weight of the web. The humectant facilitates formation of a visible aerosol by acting as an aerosol precursor. When a smoker exhales an aerosol
20 containing the flavored tobacco response and the humectant, the humectant condenses in the atmosphere, and the condensed humectant provides the appearance of conventional cigarette smoke.

Because the tobacco flavor material 61 of the
25 present invention is disposed on the surface of the carrier 59, its flavor delivery properties can be spatially varied to allow the flavor delivery profile from puff to puff to be selectively varied. For example, the tobacco flavor material 61 adjacent a first heater element 43 can contain a
30 first amount or type of flavorant whereas the tobacco flavor material adjacent a second heater element can contain a second different amount or type of flavorant. Thus, the flavored tobacco response delivery to a smoker can be selectively varied or tailored by employing non-uniform
35 tobacco flavor material profiles disposed on the surface of the carrier material. The smoker might, for example, orient the disposable cigarette 23 relative to the permanent heater

- 17 -

elements in a particular manner when the cigarette is inserted into the lighter 25, if it is desired that a particular heater heat a predetermined portion of the non-uniform tobacco flavor material.

5 Additionally, the flavored tobacco response may be selectively varied in accordance with the invention by providing a controlled amount of energy to the heater elements 43. For example, if the amount of energy delivered to the first heater element 43 (e.g., 20 Joules) is greater
10 than the amount delivered to the second (e.g., 15 Joules), then the temperature that the first heater achieves is generally greater than that of the second. Therefore, the first heater element generally generates more flavored tobacco response than the second. In this manner, the
15 amount of flavored tobacco response can be selectively controlled by varying the amount of energy delivery from puff to puff.

 The cigarette 23 is preferably a substantially constant diameter along its length and, like conventional
20 cigarettes, is preferably between approximately 7.5 mm and 8.5 mm in diameter so that a smoker has a similar "mouth feel" with the smoking system 21 as with a conventional cigarette. In the presently preferred embodiment, the cigarette 23 is 58 mm in length, overall, thereby
25 facilitating the use of conventional packaging machines in the packaging of such cigarettes. The combined length of the mouthpiece filter 71 and the second free-flow filter 73 is preferably 30 mm. The tipping paper 75 preferably extends 5 mm past the end of the second free-flow filter 73
30 and over the tobacco web 57. The length of the tobacco web 57 is preferably 28 mm. The tobacco web 57 is supported at opposite ends by the back-flow filter 63, which is preferably 7 mm in length, and the first free-flow filter 65, which is preferably 7 mm in length. The cavity 79
35 defined by the tobacco web 57, the back-flow filter 63, and the first free-flow filter 65 is preferably 14 mm in length.

- 18 -

When the cigarette 23 is inserted in the orifice 27 in the first end 29 of the lighter 25, it abuts or nearly abuts an inner bottom surface 81 of the spacer 49 of the heater fixture 39, seen in FIG. 3A, adjacent the passageway 5 47 communicating with the puff-actuated sensor 45 and the opening 55 for the light sensor 53. In this position, the cavity 79 of the cigarette 23 is preferably adjacent the heater elements 43 and substantially all of that portion of the cigarette including the second free-flow filter 73 and 10 the mouthpiece filter 71 extends outside of the lighter 25. Portions of the heater elements 43 are preferably biased radially inward to facilitate holding the cigarette 23 in position relative to the lighter 25 and so that they are in a thermal transfer relationship with the tobacco web 57, 15 either directly or through the overwrap paper 69. Accordingly, the cigarette 23 is preferably compressible to facilitate permitting the heater elements 43 to press into the sides of the cigarette.

Air flow through the cigarette 23 is accomplished 20 in several ways. For example, in the embodiment of the cigarette 23 shown in FIGS. 4A and 4B, the overwrap paper 69 and the tobacco web 57 are sufficiently air permeable to obtain a desired RTD such that, when a smoker draws on the cigarette, air flows into the cavity 79 transversely or 25 radially through the overwrap paper and the tobacco web. As noted above, an air-permeable back-flow filter 69 may be used to provide longitudinal air flow into the cavity 79.

If desired, transverse air flow into the cavity 79 is facilitated by providing a series of radial perforations 30 (not shown) through the overwrap paper 69 and the tobacco web 57 in one or more regions adjacent the cavity. Such perforations have been observed to improve the flavored tobacco response and aerosol formation. Perforations having a density of approximately 1 hole per 1-2 square millimeters 35 and a hole diameter of between 0.4 mm and 0.7 mm are provided through the tobacco web 57. This results in preferred CORESTA porosity of between 100-500. The overwrap

- 19 -

paper 69 preferably has a permeability of between 100 and 1000 CORESTA. Of course, to achieve desired smoking characteristics, such as resistance to draw, perforation densities and associated hole diameters other than those described above may be used.

Transverse air flow into the cavity 79 is also facilitated by providing perforations (not shown) through both the overwrap paper 69 and the tobacco web 57. In forming a cigarette 23 having such perforations, the overwrap paper 69 and the tobacco web 57 are attached to one another and then perforated together or are perforated separately and attached to one another such that the perforations in each align or overlap.

A presently preferred embodiment of the heater fixture 39 is seen with reference to FIGS. 3A-3B. An exploded view of a modified embodiment of a heater fixture 39A having a combined spacer and base member 49A is seen with reference to FIG. 5. The member 49A of the heater fixture 39A replaces the spacer 49 and base 50 of the heater fixture 39 shown in FIG. 3A. The general functions of providing a space for receiving a cigarette 23 and of providing heater elements for heating the cigarette may, of course, be accomplished with heater fixtures other than those shown in FIGS. 3A-3B and 5.

With reference to FIGS. 3A-3B, the heater fixture 39 is disposed in the orifice 27 in the lighter 25. The cigarette 23 is inserted, back-flow filter 63 first, in the orifice 27 in the lighter 25 into a substantially cylindrical space of the heater fixture 39 defined by a ring-shaped cap 83 having an open end for receiving the cigarette, an optional, cylindrical protective heater sleeve 85, a cylindrical air channel sleeve 87, a heater assembly 89 including the heater elements 43, an electrically conductive pin or common lead assembly 91, which serves as a common lead for the heater elements of the heater assembly, and the spacer 49. The bottom inner surface 81 of the spacer 49 stops the cigarette 23 in a desired position in

- 20 -

the heater fixture 39 such that the heater elements 43 are disposed adjacent the cavity 79 in the cigarette. In the heater fixture 39A shown in FIG. 5, the bottom inner surface 81A of the member 49A stops the cigarette 23 in the desired
5 position in the heater fixture.

Substantially all of the heater fixture 39 is disposed inside and secured in position by a snug fit with the housing 31 of the front 33 of the lighter 25. A forward edge 93 of the cap 83 is preferably disposed at or extending
10 slightly outside the first end 29 of the lighter 25 and preferably includes an internally beveled or rounded portion to facilitate guiding the cigarette 23 into the heater
fixture 39. Portions of the heater elements 43 of the heater assembly 89 and pins 95 of the pin assembly 91 are
15 secured around an exterior surface 97 of the spacer 49 in a friction fit by a ring 99. Rear ends 101 of the heater elements 43 and rear ends 103 of, preferably, two of the pins 95 are preferably welded to pins 104 securely fitted in
and extending past a bottom outer surface 105, seen in FIG.
20 3B, of the base 50 through holes 107 in the base for connection to the circuitry 41 and the power source 37. The pins 104 are preferably sufficiently well attached to the base 50 so that they block air flow through the holes 107.
The pins 104 are preferably received in corresponding
25 sockets (not shown), thereby providing support for the heater fixture 39 in the lighter 25, and conductors or printed circuits lead from the socket to the various electrical elements. The other two pins 95 provide
additional support to strengthen the pin assembly 91. The
30 passageway 47 in the spacer 49 and the base 50 communicates with the puff-actuated sensor 45 and the light sensor 53 senses the presence or absence of a cigarette 23 in the
lighter 25.

Similarly, in the heater fixture 39A shown in FIG.
35 5, portions of the heater elements 43 of the heater assembly 89 and pins 95 of the pin assembly 91 are secured around an exterior surface 97A of the member 49A in a friction fit by

- 21 -

a ring 99. Rear ends 101 of the heater elements 43 and rear ends 103 of preferably two of the pins 95 extend past a bottom outer surface 105A of the member 49A for connection to the circuitry 41 and the power source 37.

5 The member 49A is preferably formed with a flanged end 109 in which at least two grooves or holes 107A are formed and through which the rear ends 103 of two of the pins 95 extend past the bottom outer surface 105A. The other two pins 95 provide additional strength to the pin
10 assembly 91. The rear ends 101 of the heater elements 43 are bent to conform to the shape of the flanged end 109 and extend past the bottom outer surface 105A radially outside of an outer edge 111 of the flanged end. The passageway 47 in the member 49A communicates with the puff-actuated sensor
15 45 and the light sensor 53 senses the presence or absence of a cigarette 23 in the lighter 25.

 The heater assembly 89, seen in FIGS. 3A, 5, and 6, is preferably formed from a single, laser-cut sheet of a so-called super-alloy material exhibiting a combination of
20 high mechanical strength and resistance to surface degradation at high temperatures. The sheet is cut or patterned, such as by being stamped or punched or, more preferably, by means of a CO₂ laser, to form at least a general outline 115, seen in FIG. 7, of the heater assembly
25 89.

 In the outline 115, the heater elements 43 are attached to one another at their rear ends 101 by a rear portion 117 of the cut sheet outline 115 and, at front ends 119, by a portion that forms a front portion 121 of the
30 heater assembly 89. Two side portions 123 extend between the rear portion 117 and the front portion 121. The rear portion 117 and the side portions 123, while not forming a part of the finished heater assembly 89, facilitate handling of the outline 115 during processing.

35 After the outline 115 is formed, the heater elements 43 each have a wide portion 125, which, in the finished heater assembly 89, is disposed adjacent the

- 22 -

tobacco web 57, and a narrow portion 127 for forming electrical connections with the circuitry 41. If desired, the narrow portion 127 of each heater element 43 is provided with tabs 129 near the rear end 101 to facilitate forming
5 welded connections with the pins 104 or for being fixed in sockets (not shown) for electrical connection with the circuitry 41. The general outline 115 is further processed, preferably by further cutting with a laser, to form a serpentine-shaped "footprint" 131, seen in FIGS. 6 and 8,
10 from the wide portion 125. Of course, if desired, the footprints 131 may be cut at the same time as the general outline 115.

The cut or patterned sheet is preferably electropolished to smooth the edges of the individual heater
15 elements 43. The smoothed edges of the heater elements 43 facilitate insertion of the cigarette 23 in the lighter 25 without snagging. The cut or patterned sheet is rolled around a fixture (not shown) to form a cylindrical shape. The rear portion 117 and the side portions 123 are cut away
20 and edges 133 of the front portion 121 are welded together to form a single piece, or integrated, heater assembly 89, such as is shown in FIG. 6.

The heater assembly 89 may also be made by any one of various other available methods. For example, in
25 accordance with one alternative method, the heater assembly 89 is formed from a sheet that is initially formed into a tube (not shown) and then cut to form a plurality of individual heater elements as in FIG. 6. Further, the heater assembly 89 may be formed from a plurality of
30 discrete heater elements 43 that are attached, such as by spot-welding, to a common ring or band (not shown) serving the same functions, such as serving as an electrical common for the heater elements and providing mechanical support for the heater elements, as the front portion 121. Further
35 still, the forward portion 121 of the heater assembly 89 may be welded or otherwise attached around a sizing ring (not shown) having an inside diameter substantially equal to the

- 23 -

cigarette 23. The sizing ring facilitates maintaining the cylindrical heater assembly in a desired shape and offers additional strength.

The pin assembly 91 seen in FIG. 9 is preferably formed by any one of several methods similar to those described above with reference to the heater assembly 89. Like the heater assembly 89, the individual pins 95 and a band-shaped portion for forming a front portion 135 of the pin assembly 91 are also preferably cut from a flat sheet of electrically conductive material, and are rolled and welded to form a cylindrical shape. The pin assembly 91 is preferably formed with an inside diameter substantially equal to the outside diameter of the heater assembly 89. The front portion 121 of the heater assembly 89 is then fitted inside the front portion 135 of the pin assembly 91 and the two portions are secured to one another, preferably by spot welding, such that the four pins 95 are disposed in open spaces between adjacent pairs of heater elements 43. As seen in FIG. 3B, the four pins 95 (only two of which are actually electrically connected to pins 104 extending through the base 50 in the preferred embodiment) are preferably radially disposed at 22.5° angles to adjacent ones of the eight heater elements 43 and their connected pins 104 extending through the base.

The various embodiments of the lighter according to the present invention are all designed to allow delivery of an effective amount of flavored tobacco response to the smoker under standard conditions of use. Particularly, it is presently understood to be desirable to deliver between 5 and 13 mg, preferably between 7 and 10 mg, of aerosol to a smoker for 8 puffs, each puff being a 35 ml puff having a two-second duration. It has been found that, in order to achieve such delivery, the heater elements 43 should be able to reach a temperature of between about 200°C and about 900°C when in a thermal transfer relationship with the cigarette 23. Further, the heater elements 43 should preferably consume between about 5 and about 40 Joules of

- 24 -

energy, more preferably between about 10 Joules and about 25 Joules, and even more preferably about 15 Joules. Lower energy requirements are enjoyed by heater elements 43 that are bowed inwardly toward the cigarette 23 to improve the thermal transfer relationship.

Heater elements 43 having desired characteristics preferably have an active surface area of between about 3 mm² and about 25 mm² and preferably have a resistance of between about 0.5 Ω and about 3.0 Ω . More preferably, the heater elements 43 should have a resistance of between about 0.8 Ω and about 2.1 Ω . Of course, the heater resistance is also dictated by the particular power source 37 that is used to provide the necessary electrical energy to heat the heater elements 43. For example, the above heater element resistances correspond to embodiments where power is supplied by four nickel-cadmium battery cells connected in series with a total non-loaded power source voltage of approximately 4.8 to 5.8 volts. In the alternative, if six or eight such series-connected batteries are used, the heater elements 43 should preferably have a resistance of between about 3 Ω and about 5 Ω or between about 5 Ω and about 7 Ω , respectively.

The materials of which the heater elements 43 are made are preferably chosen to ensure reliable repeated uses of at least 1800 on/off cycles without failure. The heater fixture 39 is preferably disposable separately from the lighter 25 including the power source 37 and the circuitry, which is preferably disposed of after 3600 cycles, or more. The heater element materials are also chosen based on their oxidation resistance and general lack of reactivities to ensure that they do not oxidize or otherwise react with the cigarette 23 at any temperature likely to be encountered. If desired, the heater elements 43 are encapsulated in an inert heat-conducting material such as a suitable ceramic material to further avoid oxidation and reaction.

Based on these criteria, materials for the electric heating means include doped semiconductors (e.g.,

- 25 -

silicon), carbon, graphite, stainless steel, tantalum, metal ceramic matrices, and metal alloys, such as, for example, nickel-, chromium-, and iron-containing alloys. Silicon semiconductor material that is doped with phosphorous

5 impurities to a level in the range of from 5×10^{18} impurities/cm³ to 5×10^{19} impurities/cm³, which correspond to resistivity in the range of from about 1×10^{-2} Ω -cm to about 1×10^{-3} Ω -cm, respectively, are described in copending, commonly assigned, U.S. Patent Application Serial No.

10 07/943,505, which is incorporated by reference. Suitable metal-ceramic matrices include silicon carbide aluminum and silicon carbide titanium. Oxidation resistant intermetallic compounds, such as aluminides of nickel and aluminides of iron are also suitable.

15 More preferably, however, the electric heater elements 43 are made from a heat-resistant alloy that exhibits a combination of high mechanical strength and resistance to surface degradation at high temperatures. Preferably, the heater elements 43 are made from a material

20 that exhibits high strength and surface stability at temperatures up to about 80 percent of their melting points. Such alloys include those commonly referred to as super-alloys and are generally based on nickel, iron, or cobalt. Preferably, the super alloy of the heater elements 43

25 includes aluminum to further improve the heater element's performance (e.g., oxidation resistance). Such a material is available from Haynes International, Inc. of Kokomo, Indiana, under the name Haynes® 214™ alloy. This high-temperature material contains, among other elements, about

30 75% nickel, about 16% chromium, about 4.5% aluminum and about 3% iron by weight.

As noted above, the individual heater elements 43 of the heater assembly 89 preferably include a "footprint" portion 131 having a plurality of interconnected curved

35 regions -- substantially S-shaped -- to increase the effective resistance of each heater element. The serpentine shape of the footprint 131 of the heater elements 43 provide

- 26 -

for increased electrical resistance without having to increase the overall length or decrease the cross-sectional width of the heater element. Heater elements 43 having a resistance in the range from about 0.5 Ω to about 3 Ω and
5 having a foot-print length adapted to fit in the heater fixture 39 of FIG. 3A and the heater fixture 39A of FIG. 5 preferably have N interconnected S-shaped regions, wherein N is in the range from about three to about twelve, preferably, from about six to about ten.

10 If the heater footprint 131 shown in FIG. 8 is first cut into the shape of the wide portion 125 of FIG. 7, such that the wide portion has a width W1, length L1 and thickness T, the resistance from one end 125' to the opposite end 125'' of the wide portion is represented by the
15 equation:

$$R = \frac{\rho \cdot L1}{W1 \cdot T},$$

where ρ is the resistivity of the particular material being used. After forming the footprint 131, the resistance of the footprint is increased since the effective electrical length of the resistance heater element 43 is increased and
20 the cross-sectional area is decreased. For example, after the footprint is formed in the heater element 43, the current path through the heater element is along a path P. The path P has an effective electrical length of approximately 9 or 10 \cdot W1 (for the nearly five complete turns
25 of the footprint of the heater element), in contrast to the initial electrical length of L1. Furthermore, the cross-sectional area has decreased from W1 \cdot T to W2 \cdot T. In accordance with the present invention, both the increase in electrical length and decrease in cross-sectional area have
30 a tendency to increase the overall electrical resistance of the heater element 43, as the electrical resistance is proportional to electrical length and inversely proportional to cross-sectional area.

- 27 -

Thus, forming the footprint 131 in the heater element 43 allows a smaller volume of conducting material to be used to provide a given predetermined resistance over a given heated surface area, e.g. 3 mm² to 25 mm². This feature of the present invention provides at least three benefits.

First, for a given resistance, the heater element 43 is formed from a rectangular sheet having a length that, if formed as a linear element, would have to be longer. This allows a more compact heater fixture 39 and lighter 25 to be manufactured at a lower cost.

Second, because the energy required to heat a heater element 43 to a given operating temperature in still air increases as the mass of the heater element increases, the serpentine heater element is energy-efficient in that it provides a given resistance at reduced volumes. For example, if the volume of a heater element 43 is reduced by a factor of two, the mass is also reduced by the same factor. Thus, since the energy required to heat a heater element 43 to a given operating temperature in still air is substantially proportional to the mass and heat capacity of the heater element, reducing the volume by a factor of two also reduces the required energy by two. This results in a more energy-efficient heater element 43.

A third benefit of the reduced volume of the serpentine heater element 43 is related to the time response of the heater element. The time response is defined as the length of time it takes a given heater element 43 to change from a first temperature to a second, higher temperature in response to a given energy input. Because the time response of a heater element 43 is generally substantially proportional its mass, it is desirable that a heater element with a reduced volume also have a reduced time response. Thus, the serpentine heater elements 43, in addition to being compact and energy-efficient, are also able to be heated to operating temperatures quicker. This feature of

- 28 -

the present invention also results in a more efficient heater element 43.

Thus, by providing a plurality of turns in the heater elements 43 (e.g., in the shape of a serpentine pattern), the resistance of the heater element is increased without the need to increase the length or decrease the cross-sectional area of the heater element. Of course, patterns other than that of the heater element 43 shown in FIG. 8 are available to employ the principles embodied in that configuration and thereby also provide a compact and efficient heater element.

The footprint 131 is cut into the heater elements 43 by any compatible method, preferably by a laser (preferably a CO₂ laser). Because of the small geometries used in the serpentine heater elements 43 (for example, gap B in FIG. 8 is preferably on the order of from about 0.1 mm to about 0.25 mm) laser cutting is preferable over other methods for cutting the footprint 131. Because laser energy is adapted to be concentrated into small volumes, laser energy facilitates versatile, fast, accurate and automated processing. Furthermore, laser processing reduces both the induced stress on the material being cut and the extent of heat-affected material (i.e., oxidized material) in comparison to other methods of cutting (e.g., electrical discharge machining). Other compatible methods include electrical discharge machining, precision stamping, chemical etching, and chemical milling processes. It also possible to form the footprint portion 131 with conventional die stamping methods, however, it is understood that die wear makes this alternative less attractive, at least for serpentine designs.

In addition to employing a laser for cutting the serpentine heater elements 43, a laser is preferably also used to efficiently bond together various components of the lighter (preferably an yttrium-aluminum-garnet (YAG) laser). For example, the heater assembly 89 and the pin assembly 91 are preferably spot-welded to one another employing a CO₂ or

- 29 -

YAG laser. Additionally, the rear ends 101 or the tabs 129 of the heater elements 43 are also preferably laser welded to the electrical terminal pins 104 in the base 50 or to appropriate circuit elements or sockets. Of course, various conventional bonding methods exist for bonding together various components of the lighter.

Potentially damaging thermally induced stresses in the heating elements 43 are minimized in accordance with the present invention. As seen with reference to FIG. 6, the rear end portions 101 (or the tabs 129) which are welded to the pins 104 or other electrical circuitry or components, and the footprint portions 131, which generate heat, are formed as a single-piece heater element 43, thereby avoiding the necessity of welding together separate footprint portions and end portions. Such welding has been observed to produce undesired distortions during heating of heater elements. Longitudinal centerlines of the end portions 101 or tabs 129 are preferably aligned with centerlines of the footprint portions 131. Non-aligned centerlines have also been observed to cause distortions during heating of heater elements. Further, the opposite ends 131' and 131'' of the footprints 131 preferably meet with the non-serpentine portions of the heater element 43 in a symmetrical fashion, i.e., each points in the same direction. The symmetry of the ends 131' and 131'' tends to prevent the ends of the footprints 131 from twisting in opposite directions during heating and thereby damaging the footprint. The transition areas 137' and 137'' at the ends 131' and 131'', respectively, of the footprint 131 and between the non-serpentine portions of the heater element 43 and the ends are preferably beveled, as seen in FIG. 6. The beveled transition areas 137' and 137'' are also presently understood to reduce thermally induced stresses.

The heater elements 43 and the heater fixture 39 are provided with additional characteristics to avoid other problems associated with heating and repeated heating. For example, it is expected that, during heating, the heater

- 30 -

elements 43 tend to expand. As the heater elements 43 are fixed between the positionally fixed front end 135 of the pin assembly 91 attached to the front portion 121 of the heater assembly 89 and the ring 99 near the rear ends 101 of the heater elements, expansion of the heater elements tends to result in either desired inward bending of the heater elements toward the cigarette 23 or undesired outward bending away from the cigarette. Outward bending tends to leave a thermal gap between the heater element 43 and the cigarette 23. This results in inefficient and inconsistent heating of the tobacco web 57 because of the varying degree of interfacial contact between the heater element surfaces and the cigarette.

To avoid outward bowing, the individual heater elements 43 of the heater assembly 89 are preferably shaped to have a desired inward bowing, seen in FIG. 3A. The inward bowing facilitates ensuring a snug fit and good thermal contact between the heater elements 43 and the cigarette 23. The inwardly bowed shape of the heater elements 43 is provided by any desired one of a number of possible methods, such as by shaping a cylindrical heater, such as that shown in FIG. 6, on a fixture (not shown) having the desired inward bow. Preferably, the inwardly bowed shape is formed in the heater elements 43 in a die and press (not shown) prior to shaping the heater assembly 89 into a cylinder. The inwardly bowed shape of the heater elements 43 tends to result in further inward bowing if the heater elements expand during heating. The bowing is preferably fairly gentle over the length of the footprint 131. The beveled transition areas 137' and 137'' may be more sharply bent than the more delicate footprint 131. In this manner, it is understood that concentration of thermal stresses at more vulnerable portions of the heater elements 43 is avoided.

If desired, a ring (not shown) is provided around the footprint 131 of the heater elements 43. The ring is understood to serve as a heat sink and, when the footprints

- 31 -

131 of the heater elements 43 expand upon heating, the footprints are caused to expand inwardly, toward the cigarette 23.

In addition to the above-described heater assembly 5 89, the heater fixture 39 shown in FIG. 3A also includes the spacer 49 and the heater fixture base 50. The spacer 49, seen alone in FIGS. 10A-10C, has a cylindrical outer surface 97 to which the pins 91 and the heater elements 43 are secured in a friction fit by the ring 99. The spacer 49 10 further includes a bottom wall 139, the bottom inner surface 81 of which serves to block further movement of the cigarette 23 into the lighter 25 so that the cigarette is properly positioned relative to the heater elements 43, and a cylindrical inner wall 141 to permit passage of the 15 cigarette into the spacer. A portion 47' of the passageway 47 for communication with the puff-actuated sensor 45 is formed in the bottom wall 139. The portion 47' is preferably in the form of a hole or bore extending through the bottom wall 139 parallel to a centerline of the spacer 20 49. Also, a portion 55' of the opening 55 for the light sensor 53 is formed in the bottom wall 139. A first puff orifice 143 extends from the outer surface 97 of the spacer 49 to the portion 55' of the opening. The first puff orifice 143 facilitates providing a preferred RTD during a 25 first draw on a cigarette 23 by providing an additional passage for air flow from the area surrounding the cigarette to an area adjacent the back-flow filter 63. Because the tobacco web 57 and the overwrap paper 69 tend to restrict air flow into the cigarette 23 until after a heater element 30 43 has heated an area of the cigarette, the first puff orifice 143 provides air flow to the area of the heater fixture 39 by the back-flow filter 63 of the cigarette. The back-flow filter 63 permits sufficient air flow into the cigarette 23 to provide a lower RTD than would otherwise be 35 experienced. The back-flow filter 63 is, however, preferred to be as "tight" as possible, while still permitting the above-mentioned air flow during the first puff, so that

- 32 -

aerosol remaining in the cavity 79 after a draw on a cigarette 23 does not pass back into the lighter 25 through the back-flow filter. After the first puff on the cigarette 23, the area of the tobacco web 57 and the overwrap paper 69
5 that was heated by the firing of a heater element becomes more air-transmissive. Accordingly, the air flow through the first puff orifice 143 and the back-flow filter becomes insignificant for puffs on the cigarette 23 after the first puff.

10 The base 50, seen alone in FIGS. 11A-11C, is substantially cylindrical in shape and includes a bottom wall 151, the pins or leads 104 for connection with the pins 95 and the heater elements 43 extending through the holes 107 formed in the bottom wall and past the bottom outer
15 surface 105 of the base. The base 50 is preferably formed with a cylindrical outer surface 153 and a cylindrical inner wall 155, the inner wall having a diameter larger than the outside diameter of the spacer 49 and substantially equal to the outside diameter of the ring 99. The spacer 49 is
20 preferably held in place relative to the base 50 by a friction fit between an inner wall 169 of the air channel sleeve 87, the ring 99, and the outer surface 97 of the spacer. As discussed further below, means are provided for securing the air channel sleeve 87 to the base 50. The
25 spacer and base 50 may be secured by other or additional means, such as by adhesive, by screws, and by snap-fits. Further, one or more longitudinal ridges and grooves (not shown) may be formed on the spacer and the base 50 to facilitate ensuring a desired angular relationship between
30 the spacer and the base. A portion 47'' of the passageway 47 is formed in the bottom wall 151 and preferably extends from near a centerline of the base 50 to a peripheral edge of the base. If desired, the portion 47'' is partially in the form of a groove in the bottom inner surface 157 of the
35 base, the groove being made air-tight upon installation of the spacer 49. Preferably, the portion 47'' is in the form of intersecting longitudinal and radial bored holes in the

- 33 -

bottom wall 151. A portion 55'' of the opening 55 is formed in the bottom wall. The portions 47' and 55' of the spacer 49 are aligned with the portions 47'' and 55'', respectively, of the base 50 to form the passageway 47 and the opening 55.

The member 49A in the embodiment of the heater fixture 39A shown in FIG. 5 is further seen with reference to FIGS. 12A-12D. The member 49A has a cylindrical outer surface 97A to which the pins 95 and the heater elements 43 are secured by the ring 99. The member 49A further includes a bottom wall 139A, the bottom inner surface 81A of which serves to block further movement of the cigarette 23 into the lighter 25 so that the cigarette is properly positioned relative to the heater elements 43 and a cylindrical inner wall 141A of the member to permit passage of the cigarette into the member. A first puff orifice (not shown) may also be provided in the member 49A. The passageway 47A for communication with the puff-actuated sensor 45 is formed in the bottom wall 139A. The passageway 47A is preferably in the form of a hole or bore extending through the bottom wall 139A parallel to a centerline of the member 49A. Also, the opening 55A for the light sensor 53 is formed in the bottom wall 139A. As noted above, rear ends 101 of the heater elements 43 and rear ends 103 of, preferably, at least two of the pins 95 extend past a bottom outer surface 105A of the member 49A for connection to the circuitry 41 and the power source 37. The member 49A is preferably formed with a flanged end 109 in which at least two grooves or holes 107A are formed and through which the rear ends 103 of two of the pins 95 extend past the bottom outer surface 105A. The rear ends 101 of the heater elements 43 are bent to conform to the shape of the flanged end 109 and extend past the bottom outer surface 105A radially outside of an outer edge 111 of the flanged end. The air channel sleeve 87A fits around the outer edge 111 of the flanged end 109 to further secure the ends 101 of the heater elements 43 in position.

- 34 -

Except where otherwise noted, the following discussion of the smoking system 21 refers, for purposes of ease of reference, primarily to components of the heater fixture 39 shown in FIG. 3A-3B. It is, however, understood
5 that the discussion is generally applicable to the embodiment of the heater fixture 39A shown in FIG. 5, as well as to other embodiments not specifically shown or discussed herein. As noted above, the heater fixture can include other devices capable of performing the various
10 functions of the heater fixture, such as providing a space adjacent to heater elements for heating the cigarette.

An end view of the ring 99 that secures the heater elements 43 and pins 95 around exterior surface 97 of the spacer 49 of FIG. 3A is seen with reference to FIG. 13. The
15 inside diameter of the ring 99 is sufficiently large to permit the ring to surround and secure the heater elements 43 to the cylindrical exterior surface 97 by a friction fit. Longitudinal grooves 159 are formed at 90° angles to one another around the inner periphery of the ring 99 to receive
20 the generally thicker pins 95 so that the ring is adapted to surround and secure the pins to the exterior surface 97.

The air channel sleeve 87 is attached, at a first end 161, to the base 50 and, at a second end 163, to the cap 83. The first end 161 of the air channel sleeve 87 is
25 preferably formed with an external ridge 165 for engaging an internal groove 167 on the inner wall 155 of the base 50. Likewise, the second end 163 of the air channel sleeve 87 is preferably formed with an external ridge 171 for engaging an internal groove 173 on an inner rim 175 of the cap 83. The
30 air channel sleeve 87A of the embodiment of the heater fixture 39A shown in FIG. 5 differs from the embodiment of the air channel sleeve 87 shown in FIG. 3 in that the first end 161A of the air channel sleeve 87A is preferably formed with an internal groove 165A for engaging an external ridge
35 167A on the outer edge 111 of the flanged end 109 of the member 49A. Portions of the heater elements 43 near the rear ends 101 extend between the engaging portions of the

- 35 -

member 49A and the air channel sleeve 87A. As discussed further below with reference to FIG. 17, if desired to increase air flow, one or more radial holes or bores may be provided through portions of the heater fixture 39 such as the air channel sleeve 87, preferably at points along the length of the air channel sleeve where air flow is not blocked or caused to travel through a tortuous path by the cap 83 or the spacer 49 before reaching the cigarette 23.

The cap 83 of the heater fixture 39 seen in FIG. 3A and the cap 83A of the heater fixture 39A seen in FIG. 5 are similar in all respects except that the cap 83 includes a longer inner wall 177 than the inner wall 177A of the cap 83A. The inside diameter of the inner wall 177 of the cap 83 is preferably no larger than the outside diameter of the cigarette 23, and is preferably slightly smaller so that the cigarette is compressed upon insertion in the lighter 25 and held securely in place in an interference fit. The longer inner wall 177 of the cap 39 is preferred and provides added support to the cigarette 23. For purposes of discussion, the cap 83A is shown alone in FIGS. 14A-14D.

The cap 83A is formed with a plurality of longitudinal holes or passages 179A extending through the cap from the rounded or beveled forward end 93A to a rear face 181A for providing a flow of air into the space in the heater fixture 39A for receiving the cigarette 23, between the cigarette and the air channel sleeve 87 so that a transverse (i.e., radially inward) flow of air passes through the tobacco web 57 by the footprints 131 of the heater elements 43. As seen in FIG. 3A, in the preferred embodiment of the cap 83 of the heater fixture 39, the holes or passages 179 are formed to be larger near the rear face 181 than near the forward end 93 to facilitate obtaining a desired RTD. In another embodiment of the cap, the longitudinal holes or bores are replaced with longitudinal grooves (not shown) that are formed on the inner wall of the cap. With reference to FIGS. 14A-14D, a circumferential groove 183A is formed in the rear face 181A to receive and

- 36 -

support the optional protective heater sleeve 85, seen alone in FIGS. 15A-15B. The heater sleeve 85 is a tubular member having first and second ends 185 and 187, either one of which are adapted to be received in the groove 183A. The
5 circumferential groove 183A is formed on a larger radius than the bores or passages 179A to facilitate introduction of air into the heater fixture 39 when a smoker draws on the cigarette 23.

The cap 83, seen in FIG. 3A, may be formed by a
10 molding or a machining process. The cap is preferably formed by molding a single piece cap, such as the cap 83A in FIG. 5. If formed by machining, the cap 83 is preferably formed in two pieces, an outer piece 83' and an inner piece 83'', seen in FIG. 3A, that are fitted together. A
15 circumferential recess is formed in the outer surface of the inner piece 83'' prior to fitting the inner piece inside the outer piece 83', the recess forming the groove 183 when the inner and outer pieces are attached. The machined two piece cap 83 thereby avoids the necessity of machining a single
20 piece cap to form the groove 183.

The heater sleeve 85 is removed, discarded and replaced with a new heater sleeve by the smoker at any desired smoking interval (e.g., after smoking 30-60
25 cigarettes 23). The heater sleeve 85 prevents exposing the inner wall 169 of the air channel sleeve 87 to residual aerosol that is generated in the region between the heating elements 43 and the air channel sleeve. Such aerosol is, instead, exposed to the heater sleeve 85.

The heater sleeve 85 is made from a heat-resistant
30 paper- or plastic-like material that is replaced by the smoker after a plurality of cigarettes 23 have been smoked. Thus, in contrast to the "tube-in-tube" construction including an aerosol barrier tube attached to the tobacco flavor unit described below, which is discarded with the
35 flavor unit after it has been smoked, the heater sleeve 85 of the present smoking system 21 is adapted to be re-used. Accordingly, manufacturing of the cigarette 23 is simplified

- 37 -

and the volume of material to be discarded after each cigarette has been smoked is reduced.

FIG. 16 schematically shows the preferred air flow patterns that are developed in the heater fixture 39 and the cigarette 23 when a smoker draws through the mouthpiece filter 71. Air is drawn, as a result of suction at the mouthpiece filter 71, through the longitudinal bores or passages 179, into the interior of the heater fixture 39 between the air channel sleeve or the heater sleeve (not numbered in this view), past the heater elements (not shown) in contact with the cigarette 23, and through the air permeable outer wrapper 69 and the tobacco web 57 (or through perforations formed therein) and into the cavity 79 in the cigarette. From the cavity 79, the air flows into the longitudinal passage 67 in the first free-flow filter 65, the longitudinal passage 77 in the second free-flow filter 73, and through the mouthpiece filter 71 to the smoker. The quantity and size of the passages 179 are selected to optimize total particulate matter (TPM) delivery to the smoker. In the presently preferred embodiment, six or eight passageways 179 are formed in the cap 83.

As seen in FIG. 17, if desired, other air passages are provided, instead of or in addition to the passages 179, to permit air to enter the interior of the heater fixture 39 and the cavity 79 of the cigarette 23. For example, one or more radial passages 189 may be formed in the heater fixture 39, at any desired position, usually in the air channel sleeve. Longitudinal passageways 191 may be formed in the heater fixture 39 through the base or the base and the spacer (not shown in the drawing). Also, the passageways 179 in the cap 83 may be in the form of holes or bores, as discussed above, or longitudinal grooves formed in the inner wall 177 of the cap. As discussed above, if desired, a back-flow filter 63 that permits longitudinal flow into the cavity 79 when a smoker draws on the cigarette may be provided.

- 38 -

If desired, the lighter 25 includes an optional sharpened tube (not shown) positioned inside the heater fixture 39 for piercing the back-flow filter 63 of the cigarette 23 upon insertion of the cigarette. The tube is adapted to terminate inside the cavity 79 and provide direct air flow into this cavity when a smoker draws on the cigarette 23. The tube is provided with one or more orifices at a leading end, the orifices preferably being formed in sides of the tube, as opposed to the leading end of the tube, for establishing high-velocity air flow in directions that facilitate swirling of air flow inside the cavity. Such swirling improves mixing of inlet air with the aerosol and vapor generated in the cigarette 23.

The electrical control circuitry 41 of the smoking system 21 is shown schematically in FIG. 18. The circuitry 41 includes a logic circuit 195, which is an application specific integrated circuit or ASIC, the puff-actuated sensor 45 for detecting that a smoker is drawing on a cigarette 23, the light sensor 53 for detecting insertion of a cigarette in the lighter 25, the LCD indicator 51 for indicating the number of puffs remaining on a cigarette, a power source 37, and a timing network 197. The logic circuit 195 is any conventional circuit capable of implementing the functions discussed herein. A field-programmable gate array (e.g., a type ACTEL A1010A FPGA PL44C, available from Actel Corporation, Sunnyvale, California) can be programmed to perform the digital logic functions with analog functions performed by other components, while an ASIC is required to perform both analog and digital functions in one component. Features of control circuitry and logic circuitry similar to the control circuit 41 and logic circuit 195 of the present invention are disclosed, for example, in U.S. Patent No. 5,060,671, the disclosure of which is incorporated by reference.

In the preferred embodiment, eight individual heater elements 43 (not shown in FIG. 18) are connected to a positive terminal of the power source 37 and to ground

- 39 -

through corresponding field effect transistor (FET) heater switches 201-208. Individual ones of the heater switches 201-208 will turn on under control of the logic circuit 195 through terminals 211-218, respectively. The logic circuit 5 195 provides signals for activating and deactivating particular ones of the heater switches 201-208 to activate and deactivate the corresponding ones of the heaters.

The puff-actuated sensor 45 supplies a signal to the logic circuit 195 that is indicative of smoker 10 activation (i.e., a continuous drop in pressure or air flow over a sufficiently sustained period of time). The logic circuit 195 includes debouncing means for distinguishing between minor air pressure variations and more sustained draws on the cigarette to avoid inadvertent activation of 15 heater elements in response to the signal from the puff-actuated sensor 45. The puff-actuated sensor 45 may include a piezoresistive pressure sensor or an optical flap sensor that is used to drive an operational amplifier, the output of which is in turn used to supply a logic signal to the 20 logic circuit 195. Puff-actuated sensors suitable for use in connection with the smoking system include a Model 163PC01D35 silicon sensor, manufactured by the MicroSwitch division of Honeywell, Inc., Freeport, Ill., or a type NPH-5-02.5G NOVA sensor, available from Lucas-Nova, Freemont, 25 California, or a type SLP004D sensor, available from SenSym Incorporated, Sunnyvale, California.

The cigarette insertion detecting light sensor 53 supplies a signal to the logic circuit 195 that is indicative of insertion of a cigarette 23 in the lighter 25 30 to a proper depth (i.e., a cigarette is within several millimeters of the light sensor mounted by the spacer 49 and base 50 of the heater fixture 39, as detected by a reflected light beam). A light sensor suitable for use in connection with the smoking system is a Type OPR5005 Light Sensor, 35 manufactured by OPTEK Technology, Inc., 1215 West Crosby Road, Carrollton, Texas 75006.

- 40 -

In order to conserve energy, it is preferred that the puff-actuated sensor 45 and the light sensor 53 be cycled on and off at low duty cycles (e.g., from about a 2 to 10 % duty cycle). For example, it is preferred that the

5 puff actuated sensor 45 be turned on for a 1 millisecond duration every 10 milliseconds. If, for example, the puff actuated sensor 45 detects pressure drop or air flow indicative of a draw on a cigarette during four consecutive

10 pulses (i.e., over a 40 millisecond period), the puff actuated sensor sends a signal through a terminal 221 to the logic circuit 195. The logic circuit 195 then sends a signal through an appropriate one of the terminals 211-218 to turn an appropriate one of the FET heater switches 201-208 ON.

15 Similarly, the light sensor 53 is preferably turned on for a 1 millisecond duration every 10 milliseconds. If, for example, the light sensor 53 detects four consecutive reflected pulses, indicating the presence of a cigarette 23 in the lighter 25, the light sensor sends

20 a signal through terminal 223 to the logic circuit 195. The logic circuit 195 then sends a signal through terminal 225 to the puff-actuated sensor 45 to turn on the puff-actuated sensor. The logic circuit also sends a signal through terminal 227 to the indicator 51 to turn it on. The above-

25 noted modulation techniques reduce the time average current required by the puff actuated sensor 45 and the light sensor 53, and thus extend the life of the power source 37.

The timing network 197 is preferably a constant Joules energy timer and is used to provide a shut-off signal

30 to the logic circuit 195 at terminal 229, after an individual one of the heater elements that has been activated by turning ON one of the FET heater switches 201-208 has been on for a desired period of time. In accordance with the present invention, the timing network 197 provides

35 a shut-off signal to the logic circuit 195 after a period of time that is measured as a function of the voltage of the power source, which decreases during heating of the heater

- 41 -

elements. The timing network 197 is also adapted to prevent actuation of one heater element 43 to the next as the battery discharges. Other timing network circuit configurations may also be used, such as described below.

5 During operation, a cigarette 23 is inserted in the lighter 25 and the presence of the cigarette is detected by the light sensor 53. The light sensor 53 sends a signal to the logic circuit 195 through terminal 223. The logic circuit 195 ascertains whether the power source 37 is
10 charged or whether there is low voltage. If, after insertion of a cigarette 23 in the lighter 25, the logic circuit 195 detects that the voltage of the power source 37 is low, the indicator 51 blinks and further operation of the lighter will be blocked until the power source is recharged
15 or replaced. Voltage of the power source 37 is also monitored during firing of the heater elements 43 and the firing of the heater elements is interrupted if the voltage drops below a predetermined value.

 If the power source 37 is charged and voltage is
20 sufficient, the logic circuit 195 sends a signal through terminal 225 to the puff sensor 45 to determine whether a smoker is drawing on the cigarette 23. At the same time, the logic circuit 195 sends a signal through terminal 227 to the indicator 51 so that the LCD will display the digit "8",
25 reflecting that there are eight puffs available.

 When the logic circuit 195 receives a signal through terminal 221 from the puff-actuated sensor 45 that a sustained pressure drop or air flow has been detected, the logic circuit locks out the light sensor 53 during puffing
30 to conserve power. The logic circuit 195 sends a signal through terminal 231 to the timer network 197 to activate the constant Joules energy timer. The logic circuit 195 also determines, by a downcount means, which one of the eight heater elements is due to be heated and sends a signal
35 through an appropriate terminal 211-218 to turn an appropriate one of the FET heater switches 201-208 ON. The appropriate heater stays on while the timer runs.

- 42 -

When the timer network 197 sends a signal through terminal 229 to the logic circuit 195 indicating that the timer has stopped running, the particular ON FET heater switch 211-218 is turned OFF, thereby removing power from the heater element. The logic circuit 195 also downcounts and sends a signal to the indicator 51 through terminal 227 so that the indicator will display that one less puff is remaining (i.e., "7", after the first puff). When the smoker next puffs on the cigarette 23, the logic circuit 195 will turn ON another predetermined one of the FET heater switches 211-218, thereby supplying power to another predetermined one of the heater elements. The process will be repeated until the indicator 51 displays "0", meaning that there are no more puffs remaining on the cigarette 23. When the cigarette 23 is removed from the lighter 25, the light sensor 53 indicates that a cigarette is not present, and the logic circuit 195 is reset.

Other features, such as those described below, may be incorporated in the control circuitry 41 instead of or in addition to the features described above. For example, if desired, various disabling features may be provided. One type of disabling feature includes timing circuitry (not shown) to prevent successive puffs from occurring too close together, so that the power source 37 has time to recover. Another disabling feature includes means for disabling the heater elements 43 if an unauthorized product is inserted in the heater fixture 39. For example, the cigarette 23 might be provided with an identifying characteristic that the lighter 25 must recognize before the heating elements 43 are energized.

Another embodiment of a smoking system 222 according to the present invention is seen with reference to FIG. 19. The smoking system 222 includes a disposable cigarette 224 and a reusable lighter 226 having an orifice 228 in which the cigarette is received. The smoking system 222 is a "center-draw" system in that air flow is substantially through the center of the cigarette 224 and

- 43 -

the lighter. The lighter 226 includes a power source (not shown) at an end remote from the orifice 228 and control circuitry (not shown). Like the smoking system 21, the smoking system 222 is preferably provided with features such as a puff-actuated sensor and an indicator (not shown).

The lighter 226 is covered by a housing 232 that provides an appearance similar to that of a conventional cigarette. The housing 232 is preferably tube-shaped and may be formed from heat-resistive plastic or aluminum, or may be formed from a spiral wound, two-ply heavy paper. Perforations 233 are formed in the housing 232 to permit outside air to be drawn into the lighter 226 during smoking. If desired, air passageways (not shown) are formed in the cigarette 224 or at other points along the lighter 226 to obtain desired air flows.

The cigarette 224 is similar to the cigarette 23. The cigarette 224 includes a tobacco web 257 formed of a carrier or plenum 259 which supports tobacco flavor material 261, preferably including tobacco. The tobacco web 257 is wrapped around and supported by a cylindrical back-flow filter 263 at one end and a cylindrical first free-flow filter 265 at an opposite end. The first free-flow filter may have a longitudinal passage (not shown).

The cigarette 224 also preferably includes a cylindrical mouthpiece filter 271, which is preferably a conventional RTD-type (Resistance To Draw) filter. The cigarette 224 may include a cylindrical second free-flow filter (not shown) which facilitates mixing of the vapor-phase flavored tobacco response and air similarly to the second free-flow filter 73, discussed above. The back-flow filter 263 and the first free-flow filter 265 define, with the tobacco web 257, a cavity 279 within the cigarette 224. The first free-flow filter 265, the back-flow filter 263, and the mouthpiece filter 271 are preferably attached together in accordance with a method which is compatible with conventional, high-volume assembly machinery.

- 44 -

Unlike the cigarette 23, the cigarette 224 includes an annular aerosol barrier tube 273 disposed around and spaced a predetermined distance from the tobacco web 257. The aerosol barrier tube 273 minimizes condensation of aerosol formed by heating the tobacco flavor material 261 on the inside wall of the housing 232. The aerosol barrier tube 273 is preferably secured to the cigarette 224 around the first free-flow filter 263 by a collar 275. The collar 275 and the aerosol barrier tube 273 are sufficiently rigid to prevent crushing of the cigarette 224 and to maintain alignment of the aerosol barrier tube and the exterior of the tobacco web 257 such that a substantially uniform gap between the interior of the aerosol barrier tube and the web is maintained. Overwrap or tipping paper 269 preferably secures the mouthpiece filter 271 in position adjacent the first free-flow filter 265, the collar 275, and an end of the aerosol barrier tube 273.

The lighter 226 includes a heater fixture 239 including a plurality, preferably eight, of heater elements 243 for heating the cigarette 224. The heater elements 243 are preferably linear in shape and extend from a point inside the lighter 226 near the orifice 228 to a point near a back-flow filter cavity 245 which is adapted to receive the back-flow filter 263. The heater elements 243 are connected in common at one end, preferably the end near the back-flow filter cavity 245, and are chamfered at an end near the orifice 228 to facilitate insertion of the cigarette 224 without damage to the heater elements. The heater elements 243 are received in the gap formed between the tobacco web 257 and the aerosol barrier tube 273.

A schematic view of the heater fixture 239 is shown in FIG. 20. The heater fixture 239 includes a heater base 249, a heater support 251, and a plurality of heater support arms 253, all made from thermally stable, electrically insulating material. The heaters 243 are mounted on the support arms 253. The heaters 243 are

- 45 -

electrically contacted at opposite ends 243', 243'' by conducting fingers 255A and 255B.

The ends 243' of the heaters 243 are all electrically connected together to form the "common" of the heater system. A common terminal 291 is connected to a
5 conducting plate 293 which is, in turn, connected to common conducting fingers 255A which are electrically connected to the ends 243' of the heaters 243. The plate 293 includes one or more air passageways 295 for permitting air flow to a
10 region adjacent the back-flow filter 263 of the cigarette 224 during drawing on the cigarette.

A heater collar 297 receives a neck 299 fitted around a portion of the common terminal 291 adjacent the conducting plate 293. The neck 299 is provided with one or
15 more passageways 301 for permitting air flow to the passageways 295. Conducting pins 303 extend through a portion of the heater collar 297 for forming an electrical connection between the conducting fingers 255B and the circuitry 241. The conducting fingers 255B run along the
20 outer edges of the heater support arms 253 and are individually electrically connected to the ends 243'' of the heater elements 243.

Ends 255B' of the conducting fingers 255B are preferably bent to facilitate forming a "snap fit"
25 connection between the heater collar 297 and the neck 299 in which the ends 255B' contact with the pins 303. The snap fit connection facilitates removal of the heater elements 243 from the lighter 226 for replacement or repair. The pins 303 and the common terminal 291 are received in
30 corresponding sockets (not shown) for connection of the heater elements 243 with the circuitry 241 for individual firing of the heater elements.

An embodiment of an apparatus 321 for manufacturing the portion 224' of the cigarette 224
35 comprising the tobacco web 257, the first free-flow filter 265, and the back-flow filter 263 is shown schematically in FIG. 22. Carrier material 259' for forming the carrier 259

- 46 -

is pulled from a supply roll 323 by metering rollers (not shown). The carrier material web 259' shown in this embodiment includes spaced regions of tobacco flavor material 261 that are applied to the carrier material web 5 259' at station 325, or at any desired position, such as before winding the roll 323. The carrier web 259' then passes through a means for applying adhesive including an adhesive applying station 327 where a plurality of adhesive regions 261A are applied to the surface of the carrier 10 material web 259'. Alternatively, the tobacco flavor material 261 may be applied continuously over the length of the carrier web 259' and adhesive regions 261A applied in predetermined positions on top of the tobacco flavor material.

15 A filter-applying station 329 is provided downstream from the adhesive applying station 327. The filter-applying station 329 preferably includes a rotating drum device 331 for alternately applying one of either filter 333 or filter 335 to adhesive regions 261A on the 20 carrier material web 259'. The speed of rotation of the device 331 is synchronized with the speed of the carrier web 259'.

A wrapping station 337 is provided downstream from the filter-applying station 329. The carrier web 259' is 25 wrapped around the filters 333 and 335 to form a continuous rod. After the rod is formed, it is severed at a severing station 339. The severing station 339 includes means for severing the rod through the centers of filters 333 and 335 such that the severed portions of filter 333 form two first 30 free-flow filters 265 and the severed portions of filter 335 form two back-flow filters 263 of two portions 224' for forming the cigarette 224. If desired, after severing, the back-flow filters 263 are processed to form an angled end to facilitate placing the heater elements 243 around the 35 portions 224'. After severing, each portion 224' is inserted into an aerosol barrier tube 273 at a barrier tube station (not shown) and secured therein by the collar 275.

- 47 -

The barrier tube 273 has a diameter greater than the diameter of the continuous rod and has a length at least as long as the severed individual cigarettes 224. A substantially cylindrical mouthpiece filter 271 is attached to each free-flow filter 265 and each aerosol barrier tube 273 and its corresponding mouthpiece filter 271 are overwrapped with overwrapping material at additional stations (not shown).

A further embodiment of a smoking system 421 is shown schematically with reference to FIG. 23. The smoking system 421 is arranged to provide a "peripheral draw" smoking system in which heater elements 443 of a lighter 425 are arranged inside a cavity 427 bounded by an annular portion of a cigarette 423.

The cigarette 423 includes a tobacco web 457 having tobacco flavor material 461 disposed on a surface of a carrier 459 opposite the cavity 427. The cigarette 423 further includes an aerosol barrier tube 473, a plug 475, an annular free-flow filter 465, an annular back-flow filter 463, and a mouthpiece filter 471. The free flow filter 465, the back-flow filter 463, the tobacco web 457, and the aerosol barrier tube 473 define a cavity 479 in which the flavored tobacco response is generated upon heating of the tobacco flavor material 461 with the heaters 443. The cigarette 423 is preferably wrapped with overwrap or tipping paper 469. The heater fixture 439 is provided with a plug 477 which, along with the plug 475, serves to minimize aerosol transport through the heater regions of the smoking system 421. The plug 477 is provided with through holes for permitting passage of conductors 481 for controlling the heater elements 443.

A schematic diagram of an alternative electrical control system 541 is seen with reference to FIG. 24. The control system 541 preferably fulfills several functions. It preferably sequences through the (usually) eight heater elements 43 to select the next available heater element 43 each time the puff-actuated sensor 45 is activated. It

preferably applies current to the selected heater for a predetermined duration that is long enough to produce sufficient flavored tobacco response for an average puff, but not so long that the tobacco flavor material 61 burns.

- 5 It preferably controls the indicator 51 which indicates:
(1) how much of the cigarette 23 remains (i.e., how many puffs); (2) whether the voltage of the power source 37 is out of range; (3) whether there is no cigarette loaded in the lighter 25; and (4) whether there a heater fixture is
10 loaded in the lighter, such as the heater fixture 239 which is adapted to be snap-fitted into the lighter 226.

The control system 541 also controls the total amount of energy that the power source 37 delivers to each heater element 43. Because the voltage supplied by the
15 power source 37 can vary from puff to puff, rather than possibly provide a variable amount of power and energy by activating each heater element 43 for the same amount of time, it is preferred to deliver a constant amount of energy for each puff. To deliver constant energy, the control
20 circuit 541 monitors the loaded voltage of the power source 37 while a heater element 43 is activated and continues to supply power to the heater element until a desired number of Joules of energy are delivered.

As seen in FIG. 24, the control system 541
25 includes a logic circuit 570, a BCD decoder 580, a voltage detector 590, a timing network 591, the puff actuated sensor 45, the indicator 51, and a charge pump circuit 593. The logic circuit 570 may be any conventional circuit capable of implementing the functions discussed herein, such as a
30 field-programmable logic array (e.g., a type ACTEL A1010A FPGA PL44C, available from Actel Corporation, of Sunnyvale, California) programmed to perform such functions. Preferably, the logic circuit 570 is operated at low clock cycles (e.g., 33kHz) in order to conserve energy.

35 Each heater element 43A-43H is connected to the positive terminal of the power source 37 and to ground through a respective field-effect transistor (FET) 595A-

- 49 -

595H. A particular FET 595A-595H turns on under the control of BCD-to-decimal decoder 580 (preferably a standard type CD4514B 4 to 16 line decoder) through terminals 581-588, respectively. The BCD decoder 580 receives two types of signals through the control terminal 580A from the logic circuit 570: (1) the BCD code of the particular heater 43A-43H to be activated; and (2) the ON and OFF signals for activating that heater.

The BCD decoder 580 is connected, through terminal 580B, to terminal 593A of the charge pump circuit 593 which provides the voltage which is used to drive the gates of each FET 595A-595H. The charge pump circuit 593 includes a diode 594 coupled to the power source 37 and a capacitor 595 coupled to the logic circuit 570. The logic circuit 570 includes a conventional switching network (not separately shown) coupled to terminal 572 which allows for the voltage at terminal 593B of the charge pump circuit 593 to be boosted to preferably approximately twice that of the power source 37. The diode 594 prevents such voltage from coupling back to the power source 37. Thus, the doubled voltage at the terminal 580B of the decoder 580 is used to drive the gates of FETs 595A-595H at enhanced voltage levels in order to increase the efficiency of the circuit 541. Resistors 596A-596H are coupled in series with the gates of FETs 595A-595H, respectively, and are provided to increase the charging time of the respective gates in order to reduce the generation of high frequency harmonics which might produce noise in the control system 541.

The puff actuated sensor 45 supplies a signal to the logic circuit 570 that is indicative of smoker activation (i.e., a continuous drop in pressure of approximately one inch of water). Thus, the puff actuated sensors 45 might include a piezoresistive pressure sensor that is used to drive an operational amplifier, the output of which in turn is used to supply a logic signal to the logic circuit 570. For example, the pressure sensor may be a type NPH-5-002.5G NOVA sensor, available from LucusNova,

- 50 -

of Fremont, California or a type SLP004D sensor, available from SenSymb Incorporated, of Sunnyvale, California.

In order to conserve energy, it is preferred that the puff actuated sensor 45 is cycled on and off at low duty cycles (e.g., from about a 2 to 10% duty cycle). For example, it is preferred that the puff actuated sensor 45 is turned on only for about a 0.5 ms time period every 16 ms. This modulation technique reduces the time average current required by the puff actuated sensor 45 and thus extends the lifetime of the power source 37.

The timing network 591 is used to provide a shut-off signal to the logic circuit 570 after an individual heater 43A-43H has been activated for a predetermined time period, depending upon the amount of energy that is delivered to a heater. In accordance with the present invention, it is preferred that each heater 43A-43H is activated for a period of time so that a constant amount of energy (e.g., in a range from about 5 to 40 Joules, or, more preferably, about 15 to 25 Joules) is supplied to each heater, independent of the loaded voltage of the power source 37. Thus, the terminal 591A provides to the timing network 591 information about the turn-on time of each heater 43 and the loaded voltage of the power source 37, assuming that the heater resistance is known and constant (i.e., 1.2 Ω). The terminal 591B then supplies a shut-off signal to the terminal 578 of the logic circuit 570 indicative of a time period corresponding to the delivery of a constant amount of energy.

A preferred embodiment of the timing network 591 is shown in FIG. 24. The timing network 591 includes the terminal 591A which receives a signal from the logic circuit 570 that changes from approximately zero volts to the loaded battery voltage level at the time of initial activation of an individual heater 43A-43H. This signal is filtered through a resistor-capacitor network 601 (including resistors 603-606, capacitor 607 and diode 608) and is used to drive an over-voltage detector 602. The over-voltage

- 51 -

detector 602 is preferably a type ICL7665A over/under-voltage detector available from Maxim Corporation, of Sunnyvale, California. In accordance with the present invention, the resistor-capacitor network 601 is chosen so
5 that the terminal 591B of the timing network 591 changes from a HIGH state to a LOW state at the time the predetermined constant amount of energy is delivered to each heater. Of course, other timing network circuit configurations may also be used.

10 If desired, the control circuit 541 puts a maximum time limit on the time period for delivering the constant amount of energy. For example, if the voltage of the power source 37 is so low that it would take longer than 2 seconds to deliver 20 Joules of energy, then the logic circuit 570
15 provides an automatic shut-off signal at the terminal 571 after a heater has been ON for 2 seconds even though 20 Joules of energy have not been delivered.

In an alternative embodiment of the present invention, the timing network 591 is used to provide a
20 shut-off signal to the logic circuit 570 for a predetermined time period independent of energy delivery. Thus, the timing network 591 provides a shut-off signal after, for example, a fixed time period in the range from about 0.5 second to 5 seconds.

25 The voltage detector 590 is used to monitor the voltage of the power source 37 and provide a signal to the logic circuit 170 when that voltage is either (1) lower than a first predetermined voltage (e.g., 3.2 volts) which indicates that the power source must be recharged, or (2)
30 higher than a second predetermined voltage (e.g., 5.5 volts) which indicates that the power source has been fully recharged after the voltage has fallen below the first predetermined voltage level. The voltage detector 590 is preferably a type ICL7665A over/under-voltage detector
35 available from Maxim Corporation, of Sunnyvale, California.

As discussed above, the logic circuit 570 is used to control the BCD decoder 580 through the terminal 571.

- 52 -

The logic circuit 570 also controls the indicator 51 which is used to indicate the number of puffs available to the user and which preferably is a single-digit seven segment liquid crystal display (LCD) for an eight-puff smoking system. Thus, for a newly-inserted cigarette having eight
5 respective fractions of tobacco flavor material, the indicator 51 displays an "8", whereas for a cigarette with "one" puff left, the indicator 51 displays a "1". After the last puff has been used, the indicator 51 displays a "0".

10 Additionally, the indicator 51 displays a "0" when either there is no cigarette or heater fixture or heater assembly (e.g., the snap fit heater elements 243 are not provided in the heater fixture 239) loaded into the lighter. Furthermore, to indicate that the power source voltage is
15 out of range, i.e., has fallen below the recharge level (e.g., 3.2 volts) or has not been fully recharged after the voltage has fallen below the recharge level, the indicator 51 is repetitively cycled on and off at a frequency of 0.5 Hertz. For example, if immediately after the first puff the
20 power source voltage falls below 3.2 volts, the indicator 51 blinks a "7" display twice per second.

The logic circuit 570 determines, through terminals 597A and 598A, whether a heater fixture or assembly is loaded in the lighter by measuring the
25 respective voltage drops across high-resistance resistors 597 and 598 (e.g., 1 M Ω), respectively. The resistors 597 and 598 each have one terminal permanently connected to the drains of FETs 595G and 595H, respectively, and a second terminal coupled to ground. When no heater assembly is
30 loaded into the lighter, the heaters identified by reference numerals 43G and 43H in FIG. 23 are disconnected from the drains of FETs 595G and 595H, respectively. Thus, the power source 37 is also disconnected from the drains of FETs 595G and 595H. As a result, no voltage is produced across the
35 resistors 597 and 598, which are in turn monitored by the logic circuit 570 through the terminals 597A and 598A, respectively. Therefore, when no heater fixture is loaded

- 53 -

in the lighter, the logic circuit 570 detects two "zeros" at the terminals 597A and 598A.

While a heater fixture is loaded in the electrical lighter, the power source 37 is coupled to the resistors 597 and 598 through the heaters 43G and 43H, respectively. As a result, a voltage is produced across the resistors 597 and 598 and the logic circuit 570 therefore typically detects two "ones" at the terminals 597A and 598A. The logic circuit 570 monitors two resistors (i.e., resistors 597 and 598) because if either of FETs 595G and 595H is turned ON to activate its respective heater, the respective resistor 597 or 598 becomes essentially shorted to ground. As a result, it is possible that, even with a heater fixture loaded, an erroneous indication that it was not loaded could be produced if only one resistor were used. However, if two resistors are used, then, for example, while the FET 595G is on, the voltage across the resistor 597 is close to zero and the voltage across the resistor 598 is indicative of a logical "one," and while the FET 595H is on, the voltage across the resistor 598 is close to zero and the voltage across the resistor 597 is indicative of a logical "one." Therefore, the two resistors 597, 598 are used, and the respective signals from the resistors 597 and 598 are logically ORed together by the logic circuit 570 to determine if a heater fixture is loaded in the electrical lighter.

In order to determine whether a cigarette is loaded in the lighter, the logic circuit 570 includes an additional terminal 599 that receives a signal whenever a cigarette is physically present in the lighter. The signal at the terminal 599 is produced by a conventional switch 599A which is mechanically and electrically activated by the presence of a cigarette. However, if the cigarette includes the carbon fiber mat of the present invention discussed above, it is preferable that the signal at terminal 599 be produced by connecting a single electrical probe directly to the carbon mat to monitor electrical currents that leak

- 54 -

through the mat. Since the carbon mat is not perfectly insulating, if a heater, which has one of its terminals connected to the power source 37 as in FIG. 23, is brought into contact with the carbon mat of the present invention, 5 some electrical current leaks into the carbon mat, whether or not FETs 595A-595H are activated. In accordance with the present invention such leakage current is monitored by an electrical probe connected directly to the carbon mat in order to detect the presence of a cigarette.

10 In addition to using electrical conduction through the carbon mat to determine whether a cigarette is loaded into the electrical lighter, such conduction is also be used, if desired, to determine the presence of particular types of cigarettes (e.g., a type X cigarette, as opposed to 15 a type Y cigarette). In accordance with this feature of the present invention, the logic circuit 570 is used to determine the resistivity of a carbon mat by employing two additional terminals (not shown) which contact the carbon mat in a spaced-apart relationship. By manufacturing a 20 particular type of carbon mat to have a preselected resistivity within a preselected range (i.e., by varying the type and amount of carbon fibers and/or binder included therein), uniquely corresponding to the particular type of cigarette, a resistivity measurement is used to distinguish 25 between various types of cigarettes that are inserted into an electrical lighter. This information is then used by the logic circuit 570 to provide preselected electrical energy delivery profiles.

For example, a first type or brand of cigarette is 30 manufactured with a carbon mat having a first preselected resistivity, whereas a second type or brand of cigarette is manufactured with a second yet different preselected resistivity. Thus, if the logic circuit 570 is capable of determining the resistivity associated with an inserted 35 cigarette, in situ, then such a measurement is used to actively control the application of electrical energy to the heaters of the lighter.

- 55 -

In accordance with the above feature of the present invention, the delivery conditions of electrical energy is then varied depending upon the particular type or brand of cigarette determined to be present in the lighter.

5 For example, after the logic circuit 570 determines the resistivity associated with a particular cigarette, the logic circuit 570 is constructed to supply either 15 Joules or 20 Joules of energy, depending upon the measured resistivity. Furthermore, the logic circuit 570 also

10 includes circuitry to prevent the delivery of any electrical energy, if it is determined that the resistivity corresponding to a particular cigarette is not compatible with the particular lighter in which it has been inserted.

Referring back to FIG. 23, prior to a smoker

15 taking the initial puff, the indicator 51 displays, for example, an "8" indicating that eight puffs are available. Accordingly, the logic circuit 570 puts the address of the first heater (e.g., heater 43A) on the terminal 571 so that the BCD decoder 580 selects that heater (e.g., through the

20 terminal 581) for firing upon smoker activation. When the smoker takes a puff, the puff actuated sensor 45 sends a HIGH signal through the terminal 575 to the logic circuit 570 indicating that the pressure in the lighter has fallen, e.g., by at least 1 inch of water. At that point, the logic

25 circuit 570 sends a signal through the terminal 571 to indicate to the BCD decoder 580 that the FET 595A for the first heater should be turned ON. Thereafter, the voltage at the terminal 580B of the BCD decoder 580 is coupled by the BCD decoder 580 to the gate of the first FET 595A, in

30 order to turn the heater ON.

Simultaneously with the start of activation of the first heater 43A, the timing network 591 keeps track of the instantaneous total amount of energy that has been delivered to the heater and provides a logic signal to the logic

35 circuit 570, through the terminal 578, at the instant of time when that amount reaches a predetermined amount (e.g., 20 Joules). Thereafter, the logic circuit 570 sends an OFF

- 56 -

signal through the terminal 571 to the BCD decoder 580 which, in response, causes the heater 43A to turn OFF.

Thereafter, while waiting for the smoker to take a second puff, the logic circuit 570 sends the address of the
5 second heater (e.g., 43B) to the BCD decoder 580, through the terminal 571, so that the second FET 595B is activated during the next puff by the smoker. Also, the logic circuit 570 sends a signal to the indicator 51 to display a "7",
15 indicating to the smoker that there are seven puffs left.

10 If desired, the logic circuit 570 also includes timing circuitry to prevent the smoker from taking the next puff within a predetermined period of time so as to allow the power source to recover. For example, the logic circuit 570 may include a circuit (not separately shown) which
15 prevents an ON signal from being sent to the BCD decoder 580 through the terminal 571 for a disabling period of 6 seconds after the last OFF signal was sent to the BCD decoder 580. If desired, to indicate to the smoker that the lighter is in such a disabled mode, the indicator 51 is repetitively
20 cycled on and off at a frequency of, for example, 4 Hertz (i.e., at a rate different than the rate used to indicate to the smoker that the power source voltage is out of range).

Whether or not the lighter incorporates the above puff disabling feature or the disabling indicator feature,
25 when the smoker takes a second puff of the lighter (after the predetermined disabling time, if applicable), the control circuit 541 repeats the above steps used to activate the first heater.

The above cycle then repeats until the final
30 heater has been heated. At such time, the logic circuit 570 (1) sends a signal to the indicator 51 to cause a blank display and (2) prevents further activation of any heater until a new disposable cigarette has been inserted into the lighter.

35 Although the control circuit 541 of FIG. 23 shows the logic circuit 570, the BCD decoder 580, the voltage detector 590 and the timing network 591 as individual and

- 57 -

discrete circuits, it is apparent that their functions could just as well be incorporated into a single integrated network (e.g., a single integrated circuit chip).

5 If desired, a disposable cigarette of the present invention includes means for indicating to a smoker that it has already been previously inserted into a lighter and subsequently removed. For example, in one embodiment, an unused cigarette includes a removable "tear strip" or other means which must first be removed or disengaged from the
10 cigarette before the cigarette is inserted into a lighter. As such, a previously-used cigarette no longer has an associated tear strip or other similar means attached thereto. In the alternative, an unused cigarette includes a physically-alterable region thereon which becomes torn,
15 ripped, compressed or otherwise physically altered upon insertion into a lighter. As such, a smoker is able to determine whether such a cigarette has been previously inserted into a lighter by visually observing the physically-alterable region.

20 Furthermore, if desired, a disposable cigarette also includes a means for indicating to a smoker that a particular cigarette has already been heated to generate and deliver its flavored tobacco response. For example, a cigarette may include a thermally-sensitive indication
25 region which changes color to indicate to the smoker that the cigarette has already been heated. In the alternative, the thermally-sensitive indication region can include a fusible strip which melts, open circuits, or otherwise physically changes shape, to indicate to the smoker that the
30 cigarette has already been heated. Of course, many other thermally activated means are available to indicate that a cigarette has already been heated. Furthermore, it is apparent that many other electrically or
mechanically-activated means may be used to accomplish the
35 same purpose -- i.e., indicate to the smoker that a cigarette has already been heated.

- 58 -

While this invention has been illustrated and described in accordance with a preferred embodiment, it is recognized that variations and changes may be made therein without departing from the invention as set forth in the
5 claims.

- 59 -

WHAT IS CLAIMED IS:

1. A cigarette for use in a smoking system for delivering a flavored tobacco response to a smoker, the system including at least one electrical heater means, the
5 cigarette comprising:

a carrier having first and second ends spaced apart in a longitudinal direction and having first and second surfaces, the first surface defining a cavity between the first and second ends, and the second surface including
10 an area for being disposed adjacent an electrical heater;
and

tobacco flavor material disposed on the first surface of the carrier, the tobacco flavor material generating the flavored tobacco response in the cavity for
15 delivery to a smoker when the tobacco flavor material is heated by the electrical heater,

wherein the carrier and the tobacco flavor material allow transverse air flow into the cavity.

2. The cigarette of claim 1, wherein the carrier
20 is in the form of a substantially hollow cylinder, the first surface forming an inside surface and the second surface forming an outside surface.

3. The cigarette of claim 1, further comprising:
a free-flow filter adjacent the second end of the
25 carrier, the free-flow filter providing structural support to the cigarette and allowing longitudinal air flow from the cavity; and

a back-flow filter adjacent the first end of the carrier, the back-flow filter providing structural support
30 to the cigarette and limiting longitudinal air flow through the cigarette.

4. The cigarette of claim 3, wherein the free-flow filter and back-flow filter are substantially

- 60 -

cylindrical and each has a surface defining a part of the cavity.

5. The cigarette of claim 3, further comprising a mouthpiece filter.

5 6. The cigarette of claim 5, further comprising tipping paper wrapped around the mouthpiece filter and at least a portion of the carrier to secure the mouthpiece filter to the carrier.

7. The cigarette of claim 3, further comprising
10 a second free-flow filter adjacent the first free-flow filter, and wherein the first free-flow filter and the second free-flow filter are each formed with longitudinal passageways, the longitudinal passageway of the second free-flow filter having a greater inside diameter than the
15 longitudinal passageway of the first free-flow filter.

8. The cigarette of claim 1, further comprising overwrap paper wrapped around the carrier.

9. The cigarette of claim 1, wherein the carrier is composed of a non-woven carbon fiber mat.

20 10. The cigarette of claim 1, wherein the tobacco flavor material comprises tobacco material.

11. The cigarette of claim 1, wherein the tobacco flavor material comprises a continuous sheet of tobacco material.

25 12. The cigarette of claim 1, wherein the tobacco flavor material comprises a dried slurry of tobacco material.

- 61 -

13. The cigarette of claim 1, wherein a plurality of perforations are formed in the carrier and tobacco flavor material and permit a desired transverse air flow during smoking.

5 14. The cigarette of claim 1, wherein the permeability of the carrier and the tobacco flavor material are predetermined and permit a desired transverse air flow.

15 15. A lighter for use in combination with a removable cigarette in a smoking system that delivers a flavored tobacco response to a smoker, the lighter comprising:

15 a heater fixture for receiving, through a first end, a removable cigarette, the heater fixture having means for providing a flow of air to at least a portion of the cigarette; and

a plurality of electrical heater elements disposed in the heater fixture, each of the heater elements having a surface for being disposed adjacent a surface of the portion of the cigarette to which the flow of air is provided; and

20 means for individually activating the plurality of heating elements such that a predetermined quantity of flavored tobacco response is generated in the cigarette, wherein, when a smoker draws on a cigarette inserted in the lighter, air flows transversely into the cigarette.

16. The lighter of claim 15, wherein the heater fixture includes a cap at the first end, the cap having an open end for receiving the cigarette.

30 17. The lighter of claim 16, wherein the cap provides an interference fit with the cigarette.

- 62 -

18. The lighter of claim 16, wherein the means for providing the flow of air include one or more air passageways formed in the cap.

19. The lighter of claim 18, wherein the one or
5 more air passageways are holes formed through the cap.

20. The lighter of claim 18, wherein the one or more air passageways are grooves formed on an inner wall of the cap, and wherein the grooves are bounded by the cigarette upon insertion of the cigarette into the lighter.

10 21. The lighter of claim 16, wherein the heater fixture includes a substantially cylindrical wall defining, with the cap, a space in which at least a portion of the cigarette is received.

15 22. The lighter of claim 21, wherein the means for providing the flow of air include one or more air passageways formed in the cap that permit air flow to the space.

20 23. The lighter of claim 15, wherein the heater fixture includes a substantially cylindrical wall defining a space in which at least a portion of the cigarette is received.

24. The lighter of claim 23, wherein, upon insertion of a cigarette in the lighter, air is permitted to flow between the cylindrical wall and the cigarette.

25 25. The lighter of claim 23, wherein the means for providing the flow of air include one or more air passageways formed through the substantially cylindrical wall.

- 63 -

26. The lighter of claim 25, wherein the one or more air passageways are formed adjacent the first end of the heater fixture.

27. The lighter of claim 25, wherein the one or
5 more air passageways are formed near a second end of the heater fixture.

28. The lighter of claim 25, wherein a plurality of air passageways are distributed across the cylindrical wall.

10 29. A smoking system for delivering a flavored tobacco response to a smoker, the system comprising:
a removable cigarette, the cigarette including
a carrier having first and second ends spaced
apart in a longitudinal direction and having first and
15 second surfaces, the first surface defining a cavity between the first and second ends, and
tobacco flavor material for generating a flavored tobacco response in the cavity, the tobacco flavor material being disposed on the first surface of the carrier;
20 a lighter, the lighter including
a heater fixture for receiving, through a first end, the removable cigarette, and
a plurality of electrical heater elements disposed in the heater fixture, each of the heater elements
25 having a surface for being disposed adjacent the second surface of the cigarette, the heater elements heating the tobacco flavor material to generate a flavored tobacco response in the cavity; and
means for individually activating the plurality of
30 heater elements such that a predetermined quantity of flavored tobacco response is generated in the cavity,
wherein the carrier and the tobacco flavor material allow a transverse flow of air into the cavity.

- 64 -

30. The smoking system of claim 29, wherein the carrier is in the form of a substantially hollow cylinder, the first surface forming an inside surface and the second surface forming an outside surface.

5 31. The smoking system of claim 29, wherein the cigarette further includes a free-flow filter adjacent the second end of the carrier, the free-flow filter providing structural support to the cigarette and allowing longitudinal air flow from the cavity, and a back-flow
10 filter adjacent the first end of the carrier, the back-flow filter providing structural support to the cigarette and limiting longitudinal air flow through the cigarette.

 32. The smoking system of claim 31, wherein the free-flow filter and back-flow filter are substantially
15 cylindrical and each has a surface defining a part of the cavity.

 33. The smoking system of claim 31, wherein the cigarette includes a mouthpiece filter.

 34. The smoking system of claim 33, wherein the
20 cigarette includes tipping paper wrapped around the mouthpiece filter and at least a portion of the carrier to secure the mouthpiece filter to the carrier.

 35. The smoking system of claim 31, wherein the cigarette includes a second free-flow filter adjacent the
25 first free-flow filter, and wherein the first free-flow filter and the second free-flow filter are each formed with longitudinal passageways, the longitudinal passageway of the second free-flow filter having a greater inside diameter than the longitudinal passageway of the first free-flow
30 filter.

- 65 -

36. The smoking system of claim 29, wherein the cigarette includes overwrap paper wrapped around the carrier.

37. The smoking system of claim 29, wherein the carrier is composed of a non-woven carbon fiber mat.

38. The smoking system of claim 29, wherein the tobacco flavor material comprises tobacco material.

39. The smoking system of claim 29, wherein the tobacco flavor material comprises a continuous sheet of tobacco material.

40. The smoking system of claim 29, wherein the tobacco flavor material comprises a dried slurry of tobacco material.

41. The smoking system of claim 29, wherein a plurality of perforations are formed in the carrier and tobacco flavor material and permit a desired transverse air flow during smoking.

42. The smoking system of claim 29, wherein the permeability of the carrier and the tobacco flavor material are predetermined and permit a desired transverse air flow during smoking.

43. The smoking system of claim 29, wherein the heater fixture includes a cap at the first end, the cap having an open end for receiving the cigarette.

44. The smoking system of claim 43, wherein the cap provides an interference fit with the cigarette.

- 66 -

45. The smoking system of claim 43, wherein one or more air passageways for providing a flow of air to at least a portion of the cigarette are formed in the cap.

5 46. The smoking system of claim 45, wherein the one or more air passageways are holes formed through the cap.

47. The smoking system of claim 45, wherein the one or more air passageways are grooves formed on an inner wall of the cap, and wherein the grooves are bounded by the
10 cigarette upon insertion of the cigarette into the lighter.

48. The smoking system of claim 43, wherein the heater fixture includes a substantially cylindrical wall defining, with the cap, a space in which at least a portion of the cigarette is received.

15 49. The smoking system of claim 48, wherein one or more air passageways for providing a flow of air to the cigarette are formed in the cap and permit air flow to the space.

20 50. The smoking system of claim 29, wherein the heater fixture includes a substantially cylindrical wall defining a space in which at least a portion of the cigarette is received.

51. The smoking system of claim 50, wherein, upon insertion of a cigarette in the lighter, air is permitted to
25 flow between the cylindrical wall and the cigarette.

52. The smoking system of claim 50, wherein one or more air passageways for providing a flow of air to at least a portion of the cigarette are formed through the substantially cylindrical wall.

- 67 -

53. The smoking system of claim 52, wherein the one or more air passageways are formed adjacent the first end of the heater fixture.

54. The smoking system of claim 52, wherein the one or more air passageways are formed near a second end of the heater fixture.

55. The smoking system of claim 52, wherein a plurality of air passageways are distributed across the cylindrical wall.

56. A heater element for use in a smoking system for delivering a flavored tobacco response to a smoker, comprising:

a first end, a second end, and a plurality of curved regions between the first and second ends for increasing electrical resistance of the heater element, the heater element being formed from resistive material having first and second surfaces substantially oriented in a plane and having an overall length L , overall width W , and thickness T , wherein the effective electrical length of the heater element is greater than the length L and the effective electrical cross-sectional area of the heater element is less than the product of W and T .

57. The heater element of claim 56, wherein the plurality of curved regions comprise a plurality of interconnected substantially S-shaped regions.

58. The heater element of claim 57, comprising N interconnected S-shaped regions, wherein N is greater than three and less than twelve.

59. The heater element of claim 58, wherein N is greater than six and less than ten.

- 68 -

60. The heater element of claim 56, wherein the heater element has a resistance in the range from about 0.8 Ω to about 2.1 Ω .

5 61. The heater element of claim 56, wherein the resistive material comprises a material that exhibits surface stability at temperatures up to about 80 percent of its melting point.

62. The heater element of claim 56, wherein the resistive material is a super alloy.

10 63. The heater element of claim 62, wherein the super alloy is based on at least one material selected from the group consisting of nickel, iron, and cobalt.

64. The heater element of claim 56, wherein the resistive material is an intermetallic compound.

15 65. The heater element of claim 64, wherein the resistive material is an oxidation resistant intermetallic compound based on at least one material selected from the group consisting of aluminides of nickel and aluminides of iron.

20 66. The heater element of claim 63, wherein the resistive material includes more than about 1 percent aluminum.

25 67. The heater element of claim 56, wherein the first and second ends extend beyond the plurality of curved regions and the first and second ends and the plurality of curved regions are formed from a single piece of material.

68. The heater element of claim 56, wherein longitudinal centerlines of the first and second ends and the plurality of curved regions are aligned.

- 69 -

69. The heater element of claim 56, wherein transition areas between the first end and the plurality of curved regions and between the second end and the plurality of curved regions is beveled.

5 70. The heater element of claim 56, wherein end curves of the plurality of curved regions adjacent the first and second ends point in a common direction.

71. A method for manufacturing an integrated heater assembly for use in a smoking system for delivering a
10 flavored tobacco response to a smoker, comprising the steps of:

 cutting a sheet of resistive material to form a plurality of heater elements connected to one another at at least one end; and

15 forming the sheet into a cylindrical shape.

72. The method of claim 71, further comprising the step of shaping the heater elements such that at least a portion of the heater elements are bowed inwardly toward a centerline of the cylindrical shape.

20 73. The method of claim 71, further comprising the step of smoothing the edges of the heater elements.

74. The method of claim 73, wherein, during the smoothing step, the heater elements are electro-polished.

75. The method of claim 71, wherein the sheet is
25 formed into a cylindrical shape after the sheet is cut to form the plurality of heater elements.

76. The method of claim 71, further comprising the step of welding together edges of a connecting portion that connects the plurality of heater elements.

- 70 -

77. The method of claim 76, wherein, during the welding step, the edges are welded with a laser.

78. The method of claim 77, wherein the laser is a yttrium-aluminum-garnet (YAG) laser.

5 79. The method of claim 71, wherein, during the cutting step, the sheet of resistive material is cut with a laser.

80. The method of claim 79, wherein the laser is a CO₂ laser.

10 81. The method of claim 71, wherein, during the cutting step, the sheet of resistive material is cut by die stamping.

82. The method of claim 71, wherein, during the cutting step, the sheet of resistive material is cut by
15 precision stamping.

83. The method of claim 71, wherein, during the cutting step, the sheet of resistive material is cut by chemical milling.

84. The method of claim 71, wherein, during the
20 cutting step, the sheet of resistive material is cut by chemical etching.

85. A cigarette, comprising:
a thermally transmissive base web formed into a substantially cylindrical shape having an outer surface for
25 receiving heat and an inner surface; and
tobacco flavor material disposed on at least a portion of the inner surface, the tobacco material liberating a flavored tobacco response when the outer surface of the base web is heated.

- 71 -

86. The cigarette of claim 85, further comprising:

s overwrap paper wrapped around the outer surface.

87. A tobacco product adapted to cooperate with a
5 discrete source of heat, the tobacco product comprising a
web of fibrous carbon and fibrous tobacco and a tobacco
flavor material disposed along a first surface of the web,
and the fibrous carbon mat being adapted to receive heat at
at least one location along a second surface and to transfer
10 a substantial portion of the heat to portions of the tobacco
flavor material proximate to the location.

88. The tobacco product of claim 87, wherein the
web is in the form of a substantially hollow web cylinder
having an interior cavity.

15 89. The tobacco product of claim 88, further
comprising:

a free-flow filter adjacent a second end of the
web cylinder, the free-flow filter providing structural
support to the web cylinder and allowing longitudinal air
20 flow from the cavity; and

a back-flow filter adjacent a first end of the web
cylinder, the back-flow filter providing structural support
to the web cylinder and limiting longitudinal air flow from
the cavity.

25 90. The tobacco product of claim 89, wherein the
free-flow filter and back-flow filter are substantially
cylindrical and each has a surface defining a part of the
cavity.

30 91. The tobacco product of claim 89, further com-
prising a mouthpiece filter adjacent the free-flow filter.

- 72 -

92. The tobacco product of claim 91, further comprising tipping paper wrapped around the mouthpiece filter and at least a portion of the web cylinder to secure the mouthpiece filter to the web cylinder.

5 93. The tobacco product of claim 89, further comprising a second free-flow filter adjacent the first free-flow filter, and wherein the first free-flow filter and the second free-flow filter are each formed with longitudinal passageways, the longitudinal passageway of
10 the second free-flow filter having a greater inside diameter than the longitudinal passageway of the first free-flow filter.

94. The tobacco product of claim 89, further comprising overwrap paper wrapped around the web cylinder.

15 95. The tobacco product of claim 89, wherein a plurality of perforations are formed in the web cylinder and permit a desired transverse air flow during smoking.

96. The cigarette of claim 89, wherein the permeability of the web cylinder is predetermined and
20 permits a desired transverse air flow.

97. A removable cigarette for use in a smoking system, the smoking system including a lighter, for delivering to a smoker a flavored tobacco response, the lighter having electrical heating means disposed in a
25 permanent cavity, the removable cigarette comprising:

a carrier having a first end and a second end and having a first surface and a second surface, the first surface defining a flavorant cavity for generating the flavored tobacco response between the first end and the
30 second end, and the second surface adapted to be disposed adjacent the electrical heating means;

SUBSTITUTE SHEET

- 73 -

tobacco flavor medium disposed on the first surface of the carrier, wherein when the electrical heating means is activated, a respective fraction of the tobacco flavor medium in thermal transfer relationship with the heating means is heated, generating a predetermined quantity of flavored tobacco response for delivery to the smoker; and filtering means for filtering the predetermined quantity of flavored tobacco response prior to delivery to the smoker.

10 98. The removable cigarette of claim 97, wherein the filtering means comprises:

 a free-flow filter adjacent the second end of the carrier, and adapted to be disposed between the flavorant cavity and the mouth of the smoker, for providing structural support to the cigarette; and

 a back-flow filter adjacent the first end of the carrier for filtering the back-flow of flavored tobacco response so as to reduce the condensation of residual flavored tobacco response on any of (a) the heating means, and (b) portions of the permanent cavity, of the lighter.

 99. The removable cigarette of claim 98, wherein: the carrier forms a substantially hollow cylinder with an inside surface and an outside surface, the electrical heating means being disposed adjacent the outside surface of the carrier; and

 the tobacco flavor medium is disposed on the inside surface of the cylindrical carrier wherein the flavored tobacco response is generated within the carrier.

 100. The removable cigarette of claim 99, wherein the free-flow filter and back-flow filter are substantially cylindrical and each has a surface which forms a part of the flavorant cavity of the carrier.

- 74 -

101. The removable cigarette of claim 100,
further comprising a substantially cylindrical aerosol
barrier tube, concentric with and having a diameter larger
than the carrier, wherein the inside surface of the barrier
5 tube and the outside surface of the carrier define a region
for accepting the electrical heating means, the barrier tube
reducing the condensation of residual flavored tobacco
response on portions of the permanent cavity of the lighter.

102. The removable cigarette of claim 101,
10 wherein the substantially cylindrical aerosol barrier tube
is attached to the free-flow filter by a collar of material
having a large resistance to draw, wherein the collar
defines the size of the heater accepting region of the
cigarette.

15 103. The removable cigarette of claim 102,
further comprising:
a substantially cylindrical mouthpiece filter
adjacent the free-flow filter; and
overwrap paper for overwrapping the aerosol
20 barrier tube and mouthpiece filter and for securing the
mouthpiece filter to the aerosol barrier tube.

104. The removable cigarette of claim 102,
wherein the carrier is composed of a nonwoven carbon fiber
mat.

25 105. The removable cigarette of claim 104,
wherein the carbon fibers in the mat have a basis weight in
the range between about 6 g/m² and about 12 g/m².

106. The removable cigarette of claim 105,
wherein the tobacco flavor medium comprises tobacco
30 material.

107. The removable cigarette of claim 106, wherein the tobacco flavor medium comprises a continuous sheet of tobacco material.

108. The removable cigarette of claim 106,
5 wherein the tobacco flavor medium comprises a foam of tobacco material.

109. The removable cigarette of claim 106, wherein the tobacco flavor medium comprises a gel of tobacco material.

110. The removable cigarette of claim 106,
10 wherein the tobacco flavor medium comprises a dried slurry of tobacco material.

111. The removable cigarette of claim 106,
15 wherein the tobacco flavor medium comprises a dried spray-deposited slurry of tobacco material.

112. The removable cigarette of claim 106,
wherein:
the tobacco flavor medium comprises a
spatially-varying tobacco flavor medium;
20 whereby the flavor delivery to a smoker varies selectively from puff to puff.

113. The removable cigarette of claim 98,
wherein:
the carrier forms a substantially hollow cylinder
25 with an inside surface and an outside surface, the electrical heating means disposed on the inside of the carrier; and
the tobacco flavor medium is disposed on the
outside surface of the cylindrical carrier, wherein the
30 flavored tobacco response is generated outside the carrier.

- 76 -

114. The removable cigarette of claim 113, wherein the free-flow filter and back-flow filter are substantially annular and each has a surface which forms a part of the flavorant cavity for generating the flavored tobacco response.

115. The removable cigarette of claim 114, further comprising:

a substantially cylindrical aerosol barrier tube, concentric with and having a diameter larger than the carrier, wherein the inside surface of the barrier tube and the outside surface of the carrier define the flavorant cavity for generating the flavored tobacco response, the barrier tube reducing the condensation of residual flavored tobacco response on portions of the permanent cavity of the lighter.

116. The removable cigarette of claim 115, further comprising a substantially cylindrical plug of material having a large resistance to draw, and substantially filling the empty center portion of the free-flow filter.

117. The removable cigarette of claim 116, further comprising:

a substantially cylindrical mouthpiece filter adjacent the free-flow filter; and overwrap paper for overwrapping the aerosol barrier tube and mouthpiece filter and for securing the mouth-piece filter to the aerosol barrier tube.

118. The removable cigarette of claim 98, wherein the tobacco flavor medium comprises a spatially-varying tobacco flavor medium, and the flavor delivery to a smoker varies selectively from puff to puff.

- 77 -

119. The removable cigarette of claim 97, further including means for indicating to the smoker that the cigarette has been previously inserted into a lighter and subsequently removed.

5 120. The removable cigarette of claim 119, wherein the indicating means must be removed from the cigarette before the cigarette can be inserted into the lighter.

10 121. The removable cigarette of claim 119, wherein the indicating means is a region on the cigarette which becomes physically altered upon insertion of the cigarette into the lighter.

15 122. The removable cigarette of claim 97, further including means for indicating to the smoker that the cigarette has been previously heated.

123. The removable cigarette of claim 122, wherein the indicating means is thermally activated and changes color to indicate that the cigarette has been previously heated.

20 124. The removable cigarette of claim 87, wherein the carrier is composed of a nonwoven carbon fiber mat having a preselected resistivity, and wherein the resistivity corresponds to a particular type of cigarette so as to allow a control circuit of the lighter to distinguish
25 between different types of cigarettes.

125. A method for manufacturing a removable cigarette for use in a smoking system, the smoking system including a lighter, for delivering to a smoker a flavored tobacco response, the lighter having electrical heating
30 means disposed in a permanent cavity, the method comprising:

- 78 -

a) providing a carrier web having regions of tobacco flavor material;

b) applying adhesive regions to the surface of the carrier web so as to form spaced regions of adhesive in
5 between spaced regions of tobacco flavor material;

c) attaching filter material to the adhesive regions on the surface of the carrier web;

d) wrapping the carrier web around the filters to form a continuous rod of alternating regions of filters and
10 tobacco flavor material; and

e) severing the continuous rod in the filter material regions to form an individual removable cigarette.

126. The method of claim 125, wherein the step of attaching filter material comprises attaching substantially
15 cylindrical filter material.

127. The method of claim 126, wherein the step of attaching filter material comprises alternately attaching free-flow filter material and back-flow filter material to the adhesive regions to form repeated regions of free-flow
20 filter material, tobacco flavor material, and back-flow filter material.

128. The method of claim 125, wherein the step of severing the continuous rod comprises severing each filter material region substantially in half to form, alternately,
25 a pair of back-flow and a pair of free-flow filters.

129. The method of claim 128, further comprising processing the removable cigarettes to form a curved insertion end on the back-flow filters.

130. The method of claim 128, further comprising
30 attaching a substantially cylindrical aerosol barrier tube to the free-flow filters, the barrier tube having a diameter greater than the diameter of the continuous rod and having a

- 79 -

length at least as long as the severed individual cigarettes.

131. The method of claim 129, further comprising the steps of attaching a substantially cylindrical mouthpiece filter to each free-flow filter;
5 overwrapping each aerosol barrier tube and its corresponding mouthpiece filter with overwrapping material.

132. An apparatus for manufacturing a removable cigarette for use in a smoking system, the smoking system including a lighter, for delivering to a smoker a flavored tobacco response, the lighter having electrical heating means disposed in a permanent cavity, the apparatus comprising:
10

means for providing a carrier web having regions of tobacco flavor material;
15

an adhesive applying station for applying adhesive regions to the surface of the carrier web so as to form spaced regions of adhesive in between spaced regions of tobacco flavor material;

20 a filter attaching station for attaching filters to the adhesive regions on the surface of the carrier web;

a wrapping station for wrapping the carrier web around the filters to form a continuous rod of alternating regions of filter and tobacco flavor material; and

25 a severing station for severing the continuous rod in the filter regions to form individual removable cigarettes.

133. The apparatus of claim 132, wherein the filter attaching station is for attaching substantially cylindrical filters.
30

134. The apparatus of claim 133, wherein the filter attaching station is for alternately attaching free-flow and back-flow filters to the adhesive regions to

- 80 -

form repeated regions of free-flow filter, tobacco flavor material, arid back-flow filter.

135. The apparatus of claim 132, wherein the severing station is for severing each filter substantially
5 in half.

136. The apparatus of claim 133, further comprising a station to form a curved insertion end on back-flow filters.

137. The apparatus of claim 135, further
10 comprising a barrier tube attachment station for attaching a substantially cylindrical aerosol barrier tube to each free-flow filter, the barrier tube having a diameter greater than the diameter of the continuous rod and having a length at least as long as the severed individual cigarettes.

15 138. The apparatus of claim 137, further comprising:
a mouthpiece filter station for attaching a substantially cylindrical mouthpiece filter to the free-flow filter; and
20 an overwrapping station for overwrapping the aerosol barrier tube and mouthpiece filter with overwrapping material.

139. An apparatus for manufacturing a removable
cigarette for use in a smoking system, the smoking system
25 including a lighter, for delivering to a smoker a flavored tobacco response, the lighter having electrical heating means disposed in a permanent cavity, the apparatus comprising:

means for providing a carrier web having regions
30 of tobacco flavor material;
adhesive applying means for applying adhesive regions to the surface of the carrier web so as to form

- 81 -

spaced regions of adhesive in between spaced regions of tobacco flavor material;

filter attaching means for attaching filters to the adhesive regions on the surface of the carrier web;

5 wrapping means for wrapping the carrier web around the filters to form a continuous rod of alternating regions of filters and tobacco flavor material; and

severing means for severing the continuous rod in the filter regions to form individual removable cigarettes.

10 140. The apparatus of claim 139, wherein the filter attaching means is for attaching substantially cylindrical filters.

141. The apparatus of claim 140, wherein the filter attaching means is for alternately attaching
15 free-flow and back-flow filters to the adhesive regions to form repeated regions of free-flow filter, tobacco flavor material, and back-flow filter.

142. The apparatus of claim 139, wherein the severing means is for severing each filter substantially in
20 half.

143. The apparatus of claim 142, further comprising means for forming a curved insertion end on back-flow filters.

144. The apparatus of claim 142, further
25 comprising barrier tube attachment means for attaching a substantially cylindrical aerosol barrier tube to each free-flow filter, the barrier tube having a diameter greater than the diameter of the continuous rod and having a length substantially the same as the severed individual cigarettes.

30 145. The apparatus of claim 144, further comprising:

- 82 -

mouthpiece filter attaching means for attaching a substantially cylindrical mouthpiece filter to the free-flow filter; and

overwrapping means for overwrapping the aerosol barrier tube and mouthpiece filter with overwrapping material.

146. A permanent heater fixture for use in a smoking system, the smoking system including a lighter, the permanent heater fixture forming a part of the lighter, for delivering to a smoker a flavored tobacco response, the smoking system having a removable cigarette that has tobacco flavor medium disposed on a first surface of a carrier, the carrier having a second surface opposed to the first surface, the permanent heater fixture comprising:

15 a heater base defining a first end of a cavity for receiving the removable cigarette, the cavity having an air passageway from the first end to a second end for allowing air to pass therebetween; and

a plurality of permanent electrical heaters disposed on the heater base, the heaters each having a surface adapted to be disposed adjacent the second surface of the carrier, wherein when the electrical heating means is activated, a respective fraction of the tobacco flavor medium in thermal transfer relationship with the heating means is heated, generating a predetermined quantity of flavored tobacco response for delivery to the smoker.

147. The permanent heater fixture of claim 146, wherein the cavity is substantially cylindrical; and wherein the fixture further comprises:

30 a plurality of heater support fingers disposed from the first end of the heater base for supporting the plurality of permanent heaters, wherein

the fingers are elongated, have an inside surface and an outside surface, and are arranged to define a surface of a cylinder.

- 83 -

148. The permanent heater fixture of claim 147, wherein the plurality of permanent heaters are mounted on the inside surface of the heater support fingers.

149. The permanent heater fixture of claim 148,
5 wherein the cavity is adapted to receive a back-flow filter wherein the filter is disposed between a heater base air passageway and the plurality of permanent heaters.

150. The permanent heater fixture of claim 149, wherein the back-flow filter is substantially cylindrical.

10 151. The permanent heater fixture of claim 146, wherein the cavity forms an annulus; and wherein the fixture further comprises a plurality of heater support fingers disposed from the first end of the heater base for supporting the plurality of permanent heaters, wherein the
15 fingers are elongated, have an inside surface and an outside surface, and are arranged to define a surface of a cylinder.

152. The permanent heater fixture of claim 151, wherein the plurality of permanent heaters are mounted on the outside surface of the heater support fingers.

20 153. The permanent heater fixture of claim 152, wherein the cavity of the heater base is adapted to receive a back-flow filter wherein the filter is disposed between a heater base air passageway and the plurality of permanent heaters.

25 154. The permanent heater fixture of claim 153, wherein the back-flow filter is annular.

155. The permanent heater fixture of claim 148, wherein the plurality of permanent heaters are comprised of silicon semiconductor material.

- 84 -

156. The permanent heater fixture of claim 155,
wherein the silicon semiconductor material is doped with
phosphorous impurities to a level in the range of between
about 5×10^{18} impurities/cm³ and about 5×10^{19}
5 impurities/cm³.

157. The permanent heater fixture of claim 152,
wherein the plurality of permanent heaters are comprised of
silicon semiconductor material.

158. The permanent heater fixture of claim 157,
10 wherein the silicon semiconductor material is doped with
phosphorous impurities to a level in the range of between
about 5×10^{18} impurities/cm³ and about 5×10^{19}
impurities/cm³.

159. A smoking system for delivering to a smoker
15 a flavored tobacco response, the smoking system comprising:
a lighter, the lighter including
a heater base defining a first end of a
cavity for receiving a removable cigarette, the cavity
having an air passageway from the first end to a second end
20 for allowing air to pass therebetween,
a plurality of permanent electrical heaters
disposed on the heater base, the heaters each having a
surface adapted to be disposed adjacent the removable
cigarette,
25 a source of electrical energy for powering
the plurality of permanent heaters, and
control means for applying the electrical
energy to the permanent heaters to selectively heat at least
one of the plurality of permanent heaters; and
30 a removable cigarette, the removable cigarette
including
a carrier having a first end and a second end
and having a first surface and a second surface, the first
surface defining a flavorant cavity for generating the

- 85 -

flavored tobacco response between the first end and the second end, and, wherein the second surface is disposed adjacent the electrical heating means,

filtering means for filtering the
5 predetermined quantity of flavored tobacco response prior to delivery to the smoker, and

tobacco flavor medium disposed on the first surface of the carrier,

wherein when any one of the plurality of
10 electrical heaters is activated, a respective fraction of the tobacco flavor medium in thermal transfer relationship with the heating means is heated, generating a predetermined quantity of flavored tobacco response for delivery to the smoker.

15 160. A smoking system for delivering to a smoker a flavored tobacco response, the smoking system comprising:

a lighter, the lighter including

electrical heating means disposed in a permanent cavity,

20 a source of electrical energy for powering the electrical heating means, and

control means for applying the electrical energy to the electrical heating means to selectively heat at least one heater element of a plurality of heater

25 elements of the electrical heating means; and

a removable cigarette, the removable cigarette including

a carrier having a first end and a second end and having a first surface and a second surface, the first
30 surface defining a flavorant cavity for generating the flavored tobacco response between the first end and the second end, wherein the second surface is disposed adjacent the electrical heating means,

filtering means for filtering the
35 predetermined quantity of flavored tobacco response prior to delivery to the smoker, and

- 86 -

tobacco flavor medium disposed on the first surface of the carrier;

wherein when any one of the plurality heater elements is activated, a respective fraction of the tobacco
5 flavor medium in thermal transfer relationship with the one of the heater elements is heated, generating a predetermined quantity of flavored tobacco response for delivery to the smoker.

161. A smoking system for delivering to a smoker
10 a flavored tobacco response, the smoking system comprising:
a permanent heater fixture including a heater base defining a first end of a cavity for receiving a removable cigarette, the cavity having an air passageway from the first end to a second end for allowing air to pass
15 therebetween;
a plurality of permanent electrical heaters disposed on the heater base, the heaters each having a surface adapted to be disposed adjacent the removable cigarette;
20 a source of electrical energy for powering the plurality of permanent heaters;
control means for applying the electrical energy to the permanent heaters to selectively heat at least one of the plurality of permanent heaters; and
25 a removable cigarette received in the heater cavity in proximity to the plurality of permanent heaters;
wherein when any one of the plurality of electrical heaters is activated, a respective fraction of the tobacco flavor medium in thermal transfer relationship
30 with the one of the heaters is heated, generating a predetermined quantity of flavored tobacco response for delivery to the smoker.

162. The smoking system of claim 161, wherein the cavity is substantially cylindrical; and wherein the fixture
35 further comprises a plurality of heater support fingers

- 87 -

disposed from the first end of the heater base for supporting the plurality of permanent heaters, wherein the fingers are elongated, have an inside surface and an outside surface, and are arranged to define a surface of a cylinder.

5 163. The smoking system of claim 162, wherein the plurality of permanent heaters are mounted on the inside surface of the heater support fingers.

10 164. The smoking system of claim 163, wherein the cavity is adapted to receive a back-flow filter, wherein the filter is disposed between a heater base air passageway and the plurality of permanent heaters.

 165. The smoking system of claim 164, wherein the back-flow filter is substantially cylindrical.

15 166. The smoking system of claim 161, wherein the cavity of the heater base forms an annulus and, wherein the fixture further comprises a plurality of heater support fingers disposed from the first end of the heater base for supporting the plurality of permanent heaters, wherein the fingers are elongated and have an inside surface and an
20 outside surface and are arranged so as to define a surface of a cylinder.

 167. The smoking system of claim 166, wherein the plurality of permanent heaters are mounted on the outside surface of the heater support fingers.

25 168. The smoking system of claim 167, wherein a back-flow filter is disposed within the cavity and the filter is disposed between a heater base air passageway and the plurality of permanent heaters.

30 169. The smoking system of claim 168, wherein the back-flow filter is annular.

- 88 -

170. The smoking system of claim 163, wherein the plurality of permanent heaters are comprised of silicon semiconductor material.

171. The smoking system of claim 170, wherein the
5 silicon semiconductor material is doped with phosphorous impurities to a level in the range of between about 5×10^{18} impurities/cm³ and about 5×10^{19} impurities/cm³.

172. The smoking system of claim 167, wherein the
10 plurality of permanent heaters are comprised of silicon semiconductor material.

173. The smoking system of claim 172, wherein the silicon semiconductor material is doped with phosphorous impurities to a level in the range of between about 5×10^{18} impurities/cm³ and about 5×10^{19} impurities/cm³.

15 174. The smoking system of claim 161, wherein the source of electrical energy comprises a battery.

175. The smoking system of claim 174, wherein the source of electrical energy comprises a charge pump circuit coupled to the battery for boosting the voltage of the
20 battery.

176. The smoking system of claim 175, wherein the battery is disposable.

177. The smoking system of claim 175, wherein the battery is rechargeable.

25 178. The smoking system of claim 176, wherein the control means comprises:

means for selecting one of the plurality of electrical heaters; and

- 89 -

means for, when a smoker desires to puff the smoking system, applying a pulse of electrical energy to heat the selected one of the electrical heaters.

179. The smoking system of claim 178, wherein the
5 selecting means is manual.

180. The smoking system of claim 178, wherein the selecting means is automatic.

181. The smoking system of claim 180, wherein the automatic selecting means selects each of the plurality of
10 electrical heaters.

182. The smoking system of claim 180, wherein the control means further comprises sequential indication means for indicating the number of the plurality of electrical heaters that can be sequentially heated until all of the
15 plurality of electrical heaters have been activated at least once for an associated removable cigarette.

183. The smoking system of claim 182, wherein the sequential indication means comprises a liquid crystal display.

20 184. The smoking system of claim 183, wherein the liquid crystal display indicates when the battery voltage falls below a preselected LOW voltage level by repetitively cycling the display on and off.

25 185. The smoking system of claim 183, wherein the liquid crystal display indicates when the battery voltage falls below a preselected LOW voltage level and when the battery has been recharged to preselected HIGH voltage level after falling below the preselected LOW voltage level.

- 90 -

186. The smoking system of claim 183, wherein the liquid crystal display indicates when there is no removable cigarette loaded into the lighter.

187. The smoking system of claim 183, wherein the
5 liquid crystal display indicates when there is no heater fixture loaded into the lighter.

188. The smoking system of claim 178, wherein the pulse applying means applies a pulse of predetermined duration.

10 189. The smoking system of claim 178, wherein the pulse applying means applies a pulse of predetermined duration in a range from about 0.5 second to about 5 seconds depending on the desired amount of energy that is meant to be delivered to the selected one of the electrical heaters.

15 190. The smoking system of claim 178, wherein the pulse applying means applies a pulse of predetermined duration in a range from about 1 second to about 3 seconds depending upon the amount of energy delivered to the selected one of the electrical heaters.

20 191. The smoking system of claim 178, wherein the pulse applying means applies a pulse of predetermined duration in a range from about 1 second to about 2 seconds depending upon the amount of energy delivered to the selected one of the electrical heaters.

25 192. The smoking system of claim 178, wherein the pulse of electrical energy further comprises a pulse of a predetermined amount of electrical energy.

193. The smoking system of claim 178, wherein the predetermined amount of electrical energy ranges from about
30 5 Joules to about 40 Joules.

- 91 -

194. The smoking system of claim 178, wherein the predetermined amount of electrical energy ranges from about 15 Joules to about 25 Joules.

195. The smoking system of claim 178, wherein the pulse applying means comprises actuation means and applies the pulse in response to actuation of the actuation means by a smoker.

196. The smoking system of claim 178, wherein the actuation means comprises a pressure-sensitive sensor.

197. The smoking system of claim 178, wherein the actuation means is cycled on and off so as to conserve the source of electrical energy.

198. The smoking system of claim 197, wherein the actuation means is on for less than about 50 percent of a given time period.

199. The smoking system of claim 198, wherein the actuation means is on for less than about 20 percent of a given time period.

200. The smoking system of claim 199, wherein the actuation means is on for less than about 5 percent of a given time period.

201. The smoking system of claim 161, wherein the control means comprises a field-programmable logic array.

202. The smoking system of claim 178, wherein the control means further comprises a voltage detector circuit for detecting when the battery voltage falls below a preselected LOW voltage level and for detecting when the battery has been recharged to preselected HIGH voltage level after falling below the preselected LOW voltage level.

- 92 -

203. The smoking system of claim 202, wherein the preselected LOW voltage level is less than about 5 volts and the preselected HIGH voltage level is greater than about 5 volts.

5 204. The smoking system of claim 203, wherein the preselected LOW voltage level ranges from about 3 to about 3.5 volts and the preselected HIGH voltage level ranges from about 5 to about 6 about volts.

10 205. The smoking system of claim 161, wherein the carrier is composed of a nonwoven carbon fiber mat having a preselected resistivity, and wherein the resistivity corresponds to a particular type of cigarette so as to allow the lighter to distinguish between different types of cigarettes.

15 206. The smoking system of claim 205, wherein the control means comprises:

 means for selecting one of the plurality of electrical heaters; and

20 means for, when a smoker desires to puff the smoking system, applying a pulse of electrical energy to heat the selected one of the electrical heaters.

 207. The smoking system of claim 206, further comprising means to measure the preselected resistivity.

25 208. The smoking system of claim 207, wherein a first pulse of electrical energy is applied to heat the selected one of the electrical heaters if a first preselected resistivity is measured, and a second pulse of electrical energy is applied to heat the selected one of the electrical heaters if a second preselected resistivity is
30 measured.

Fig. 1

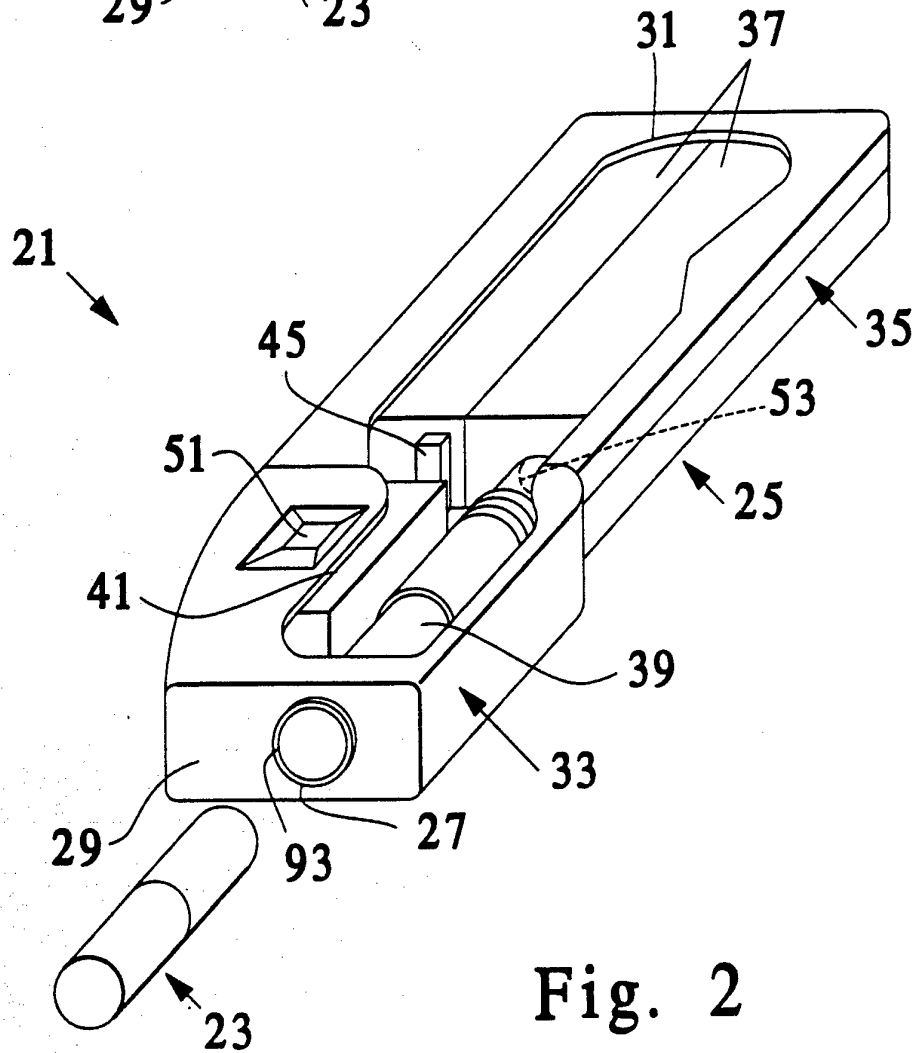
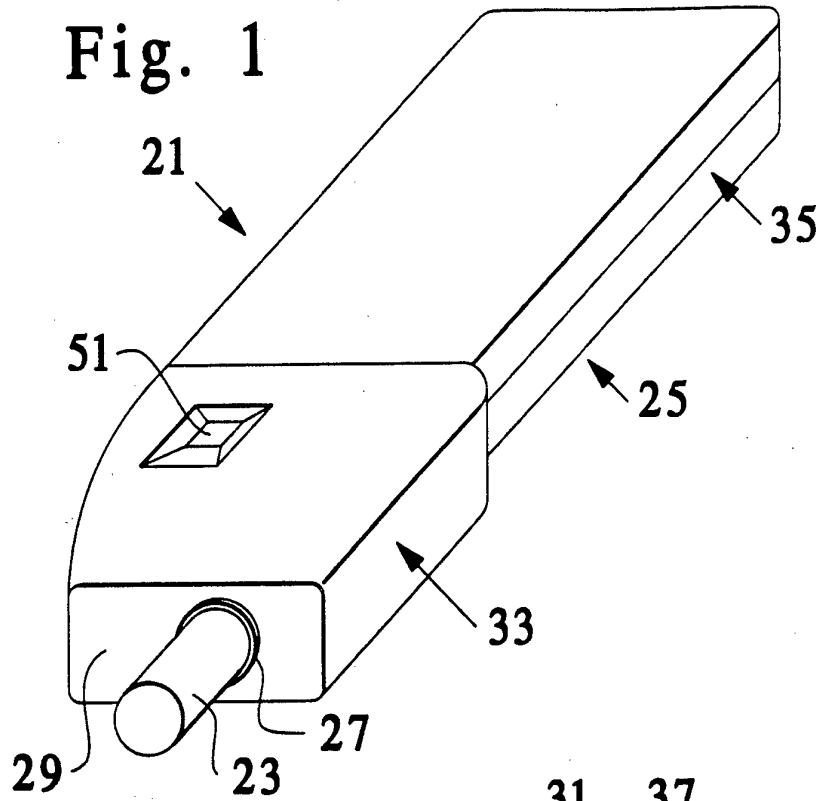

Fig. 2

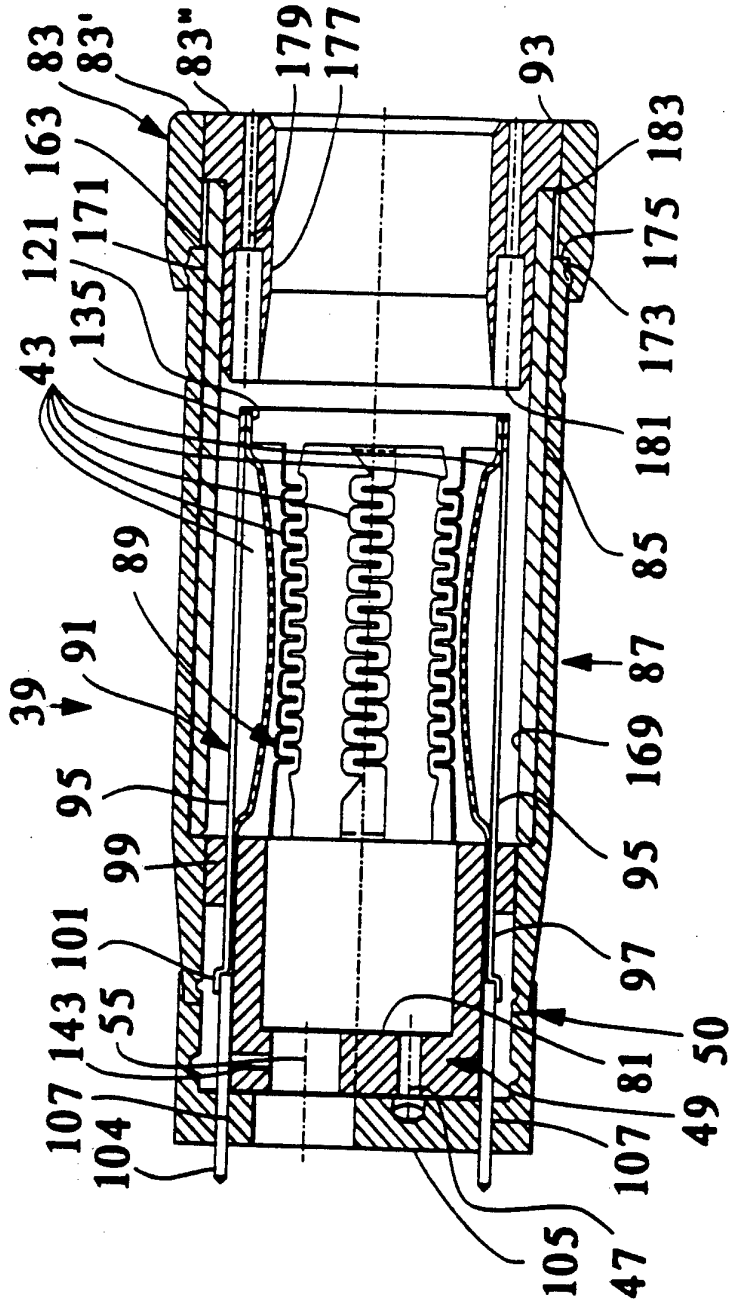

Fig.3A

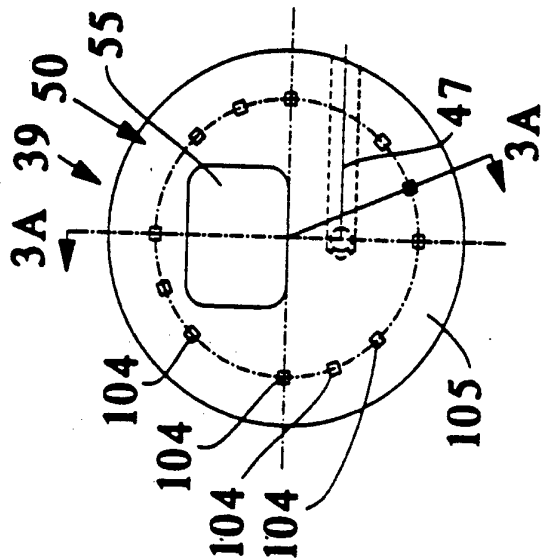

Fig.3B

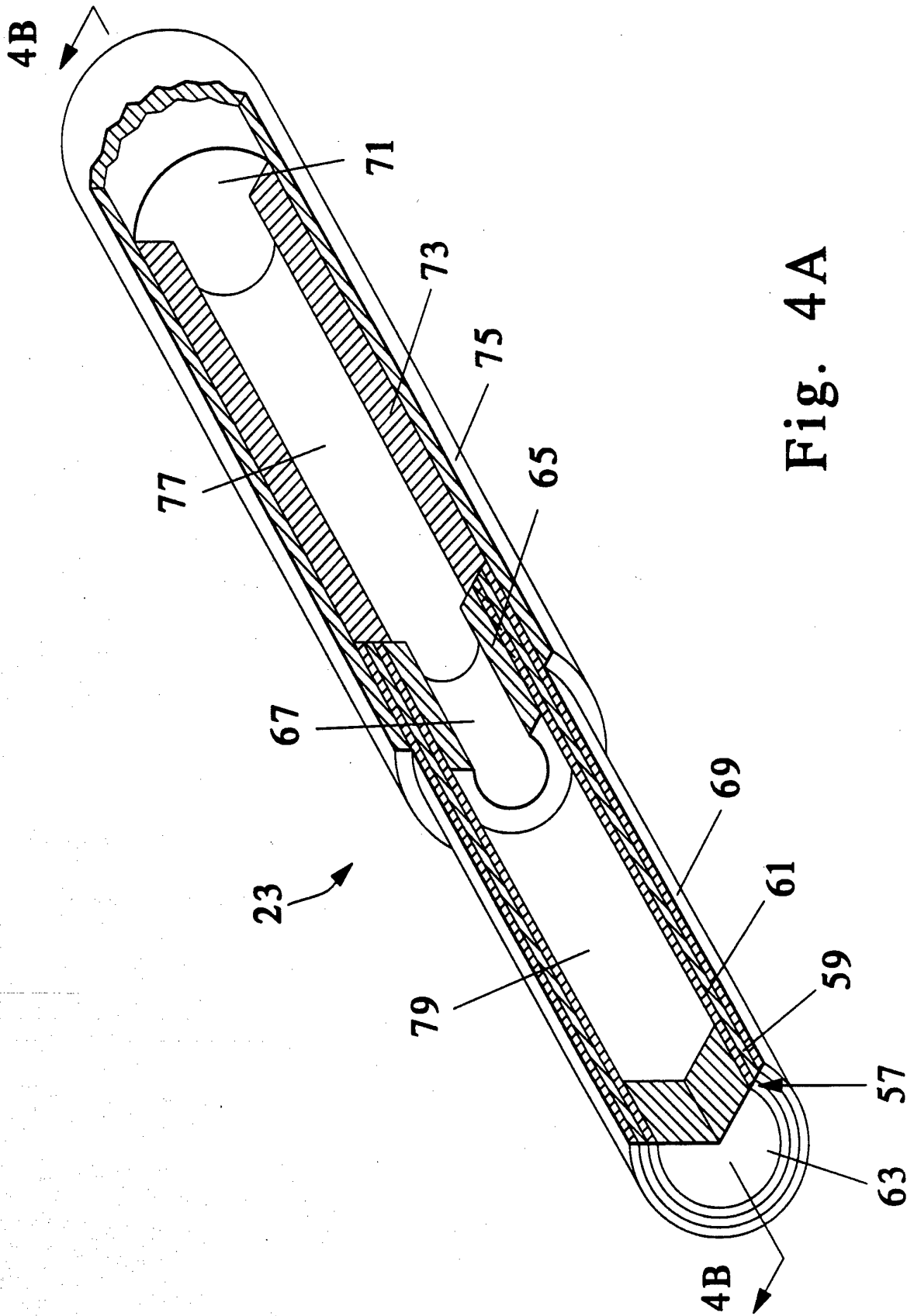

Fig. 4A

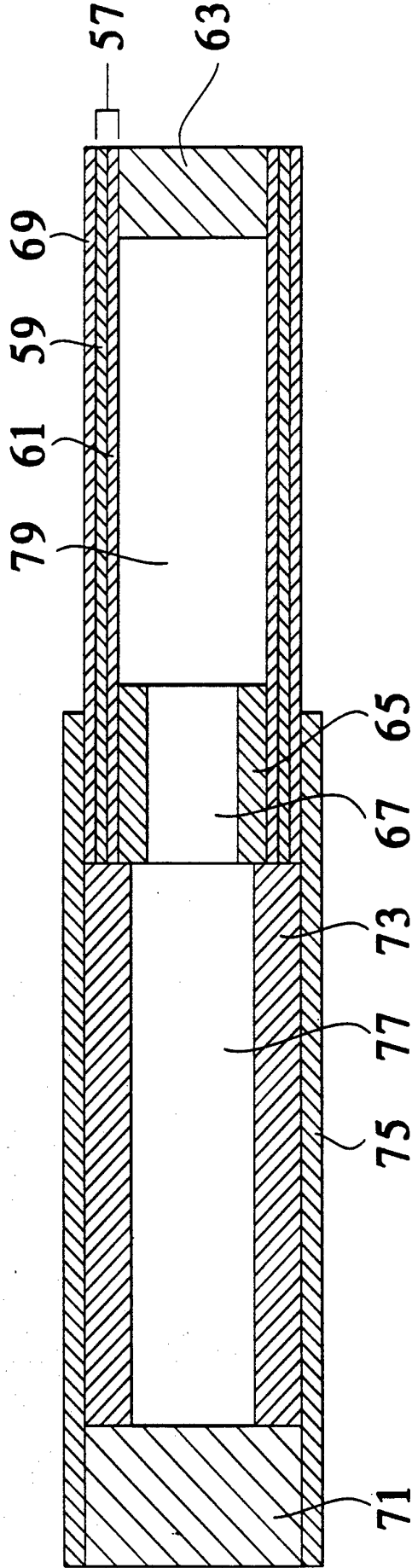
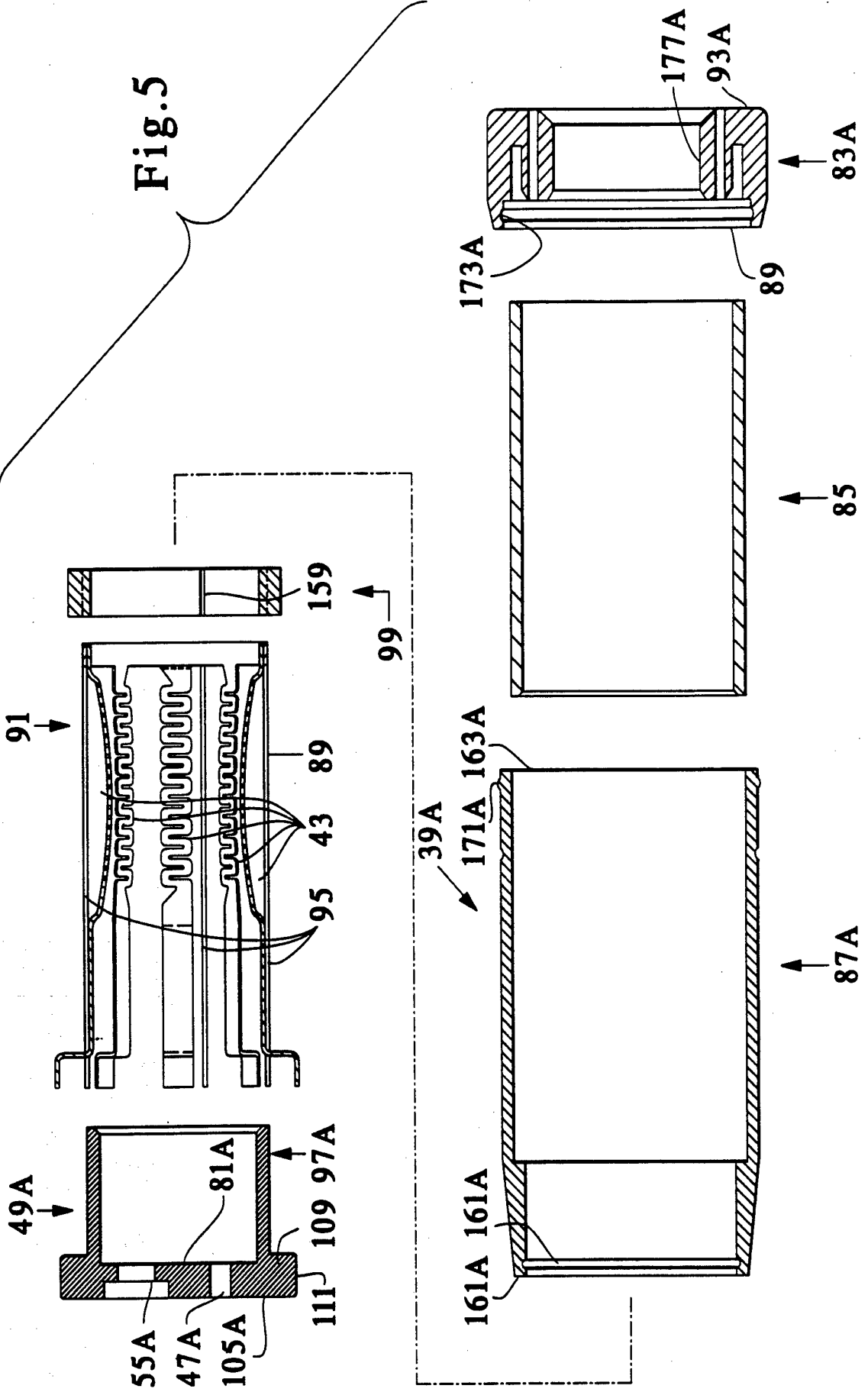

Fig. 4B

Fig.5



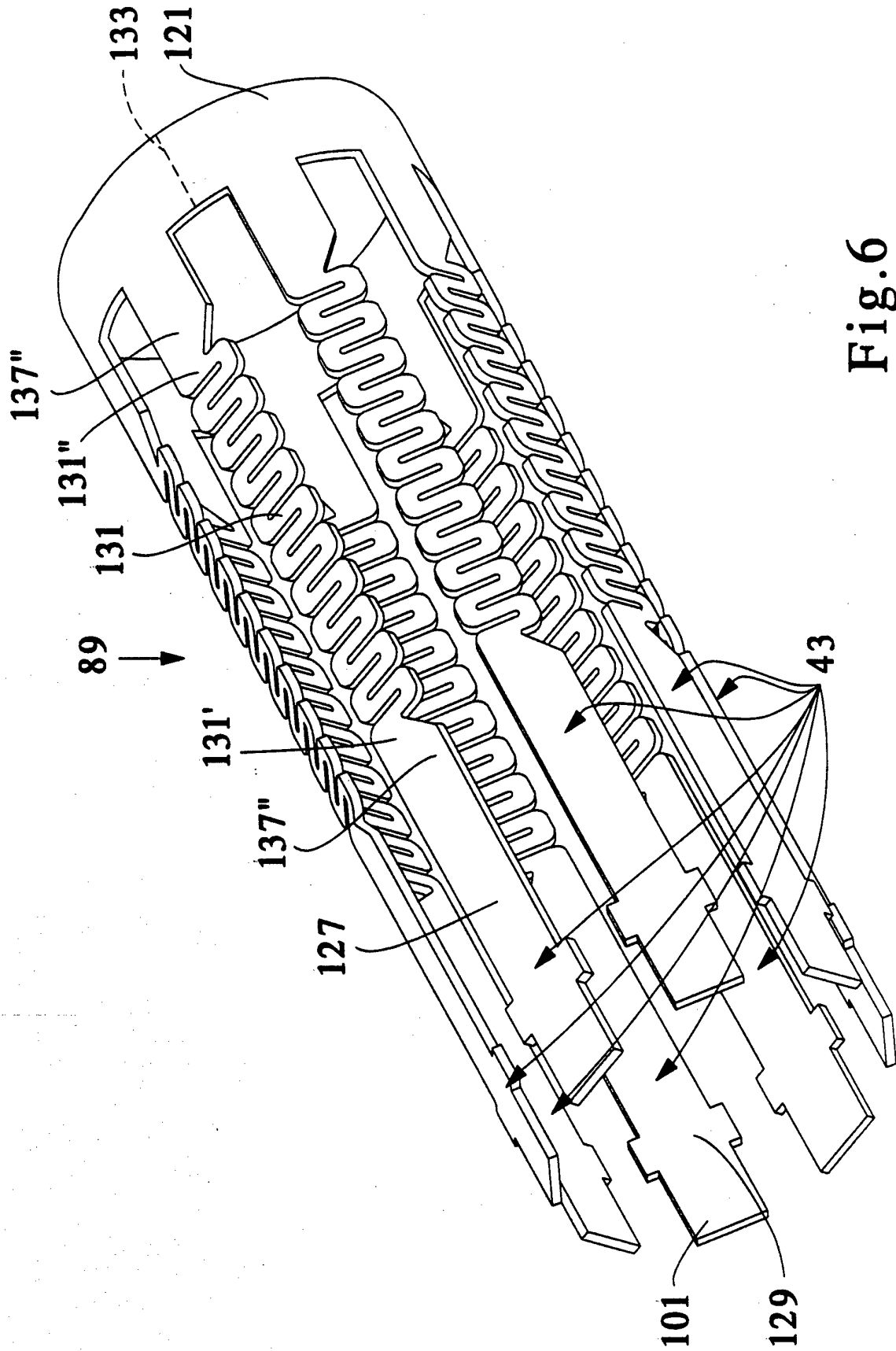
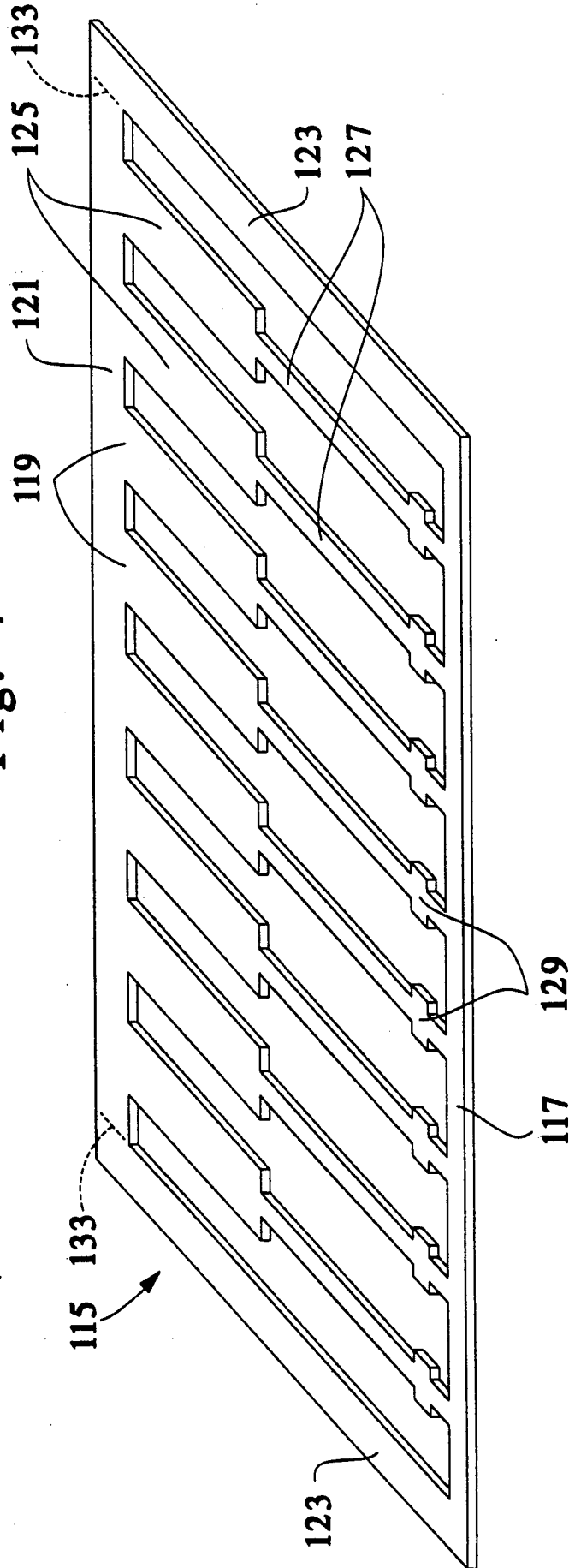

Fig.6

Fig. 7



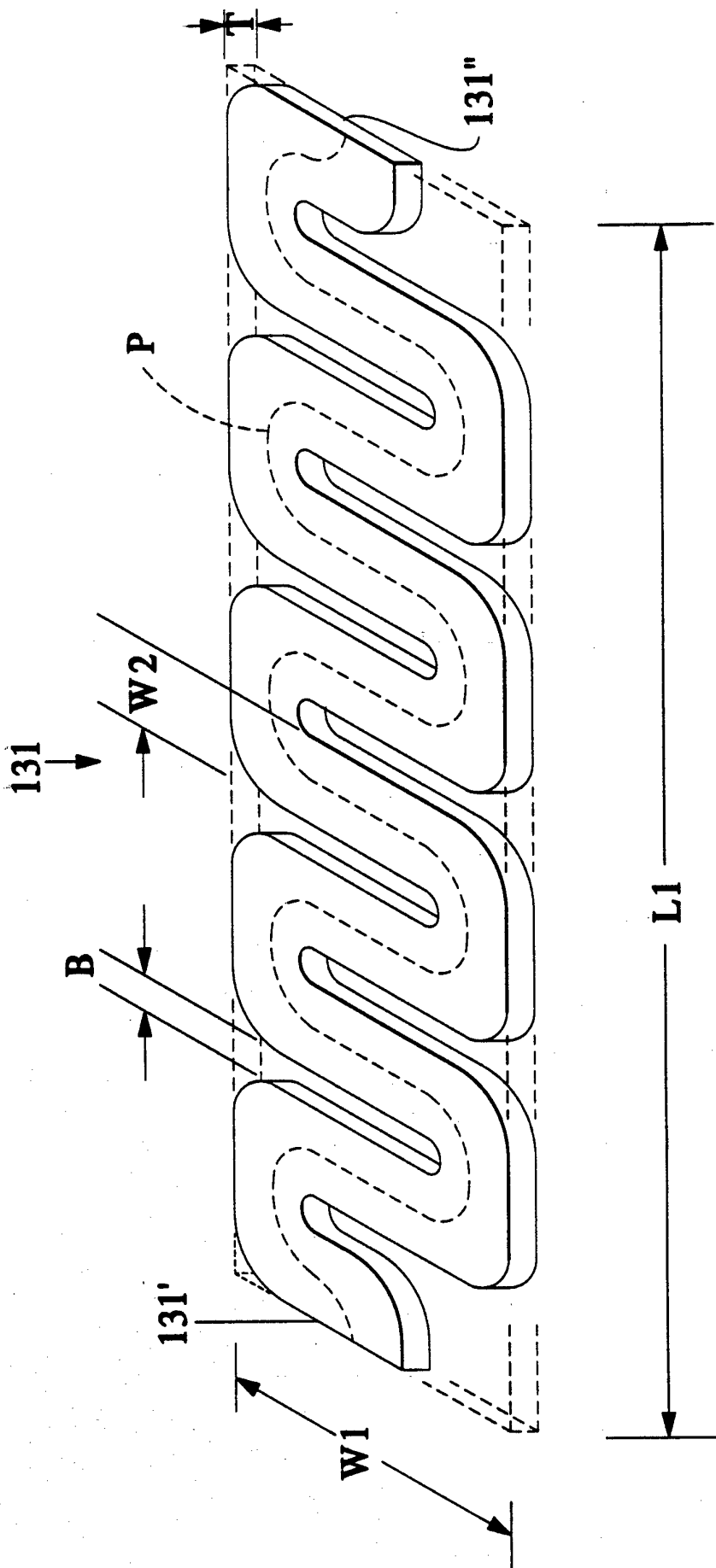

Fig.8

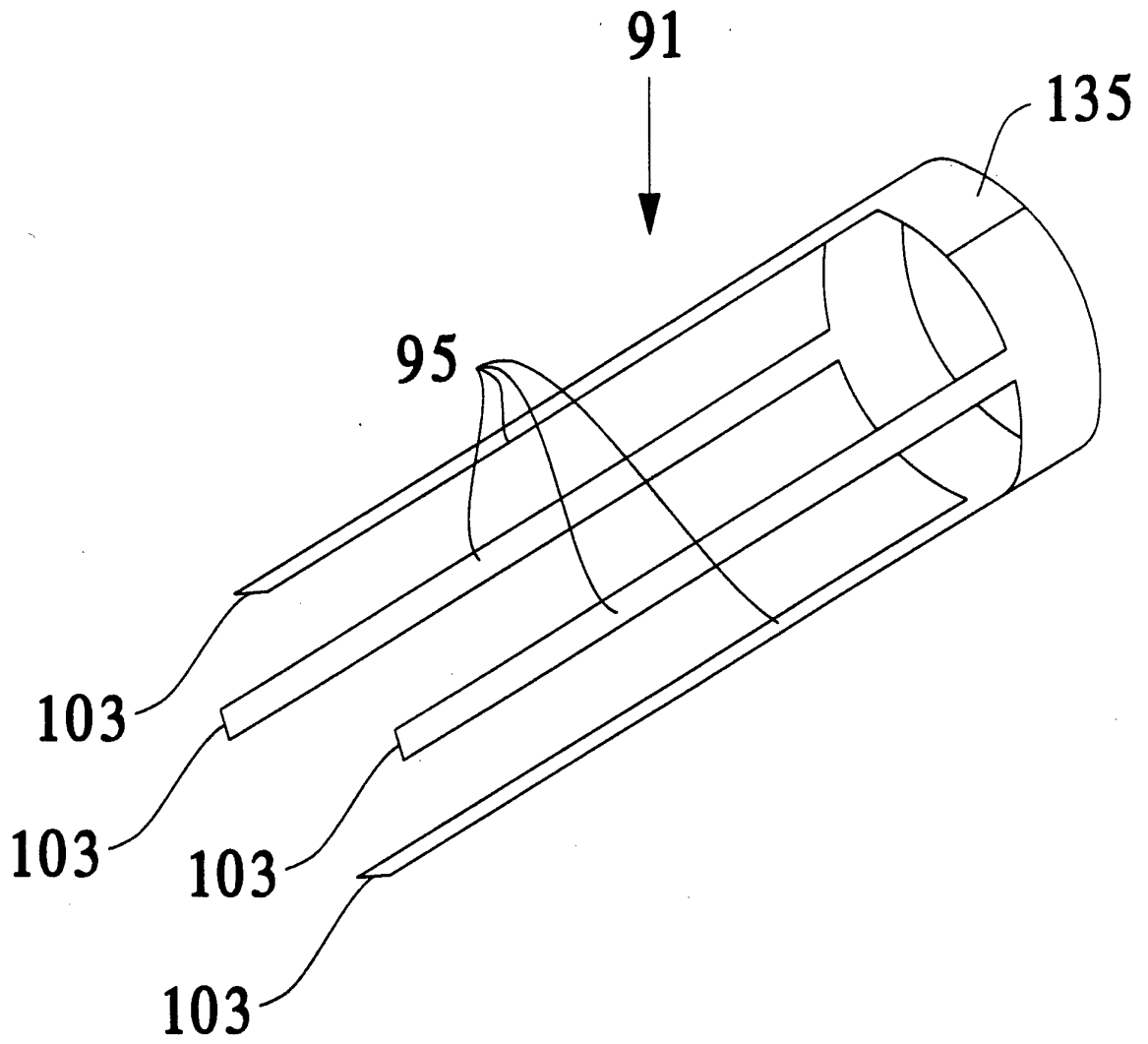

Fig.9

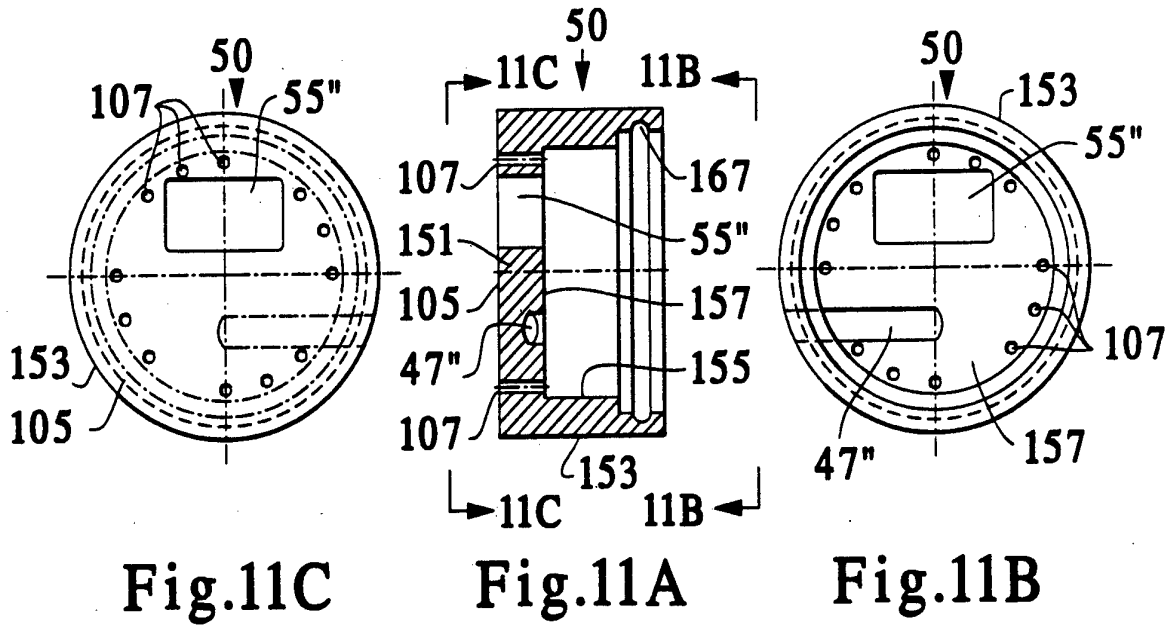

Fig.11C

Fig.11A

Fig.11B

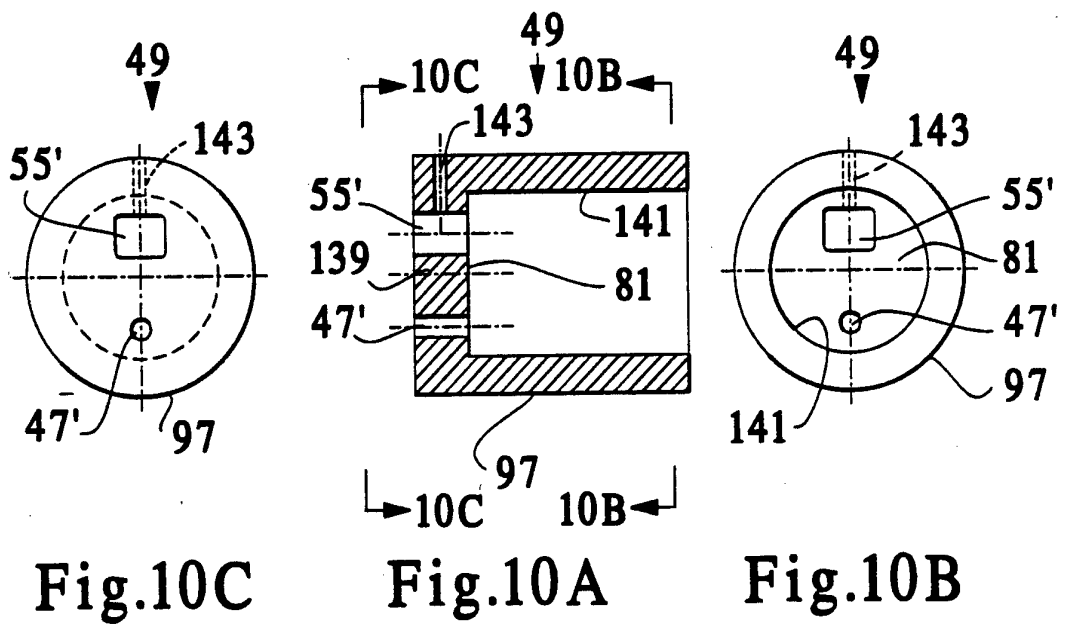
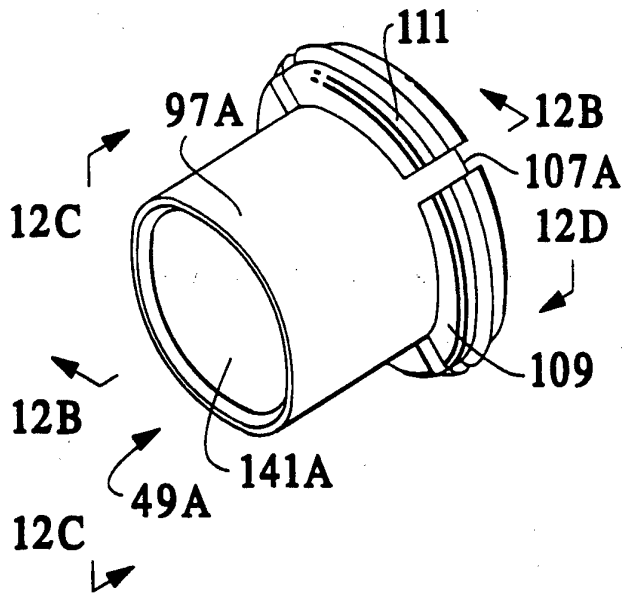

Fig.10C

Fig.10A

Fig.10B

Fig. 12A



12D

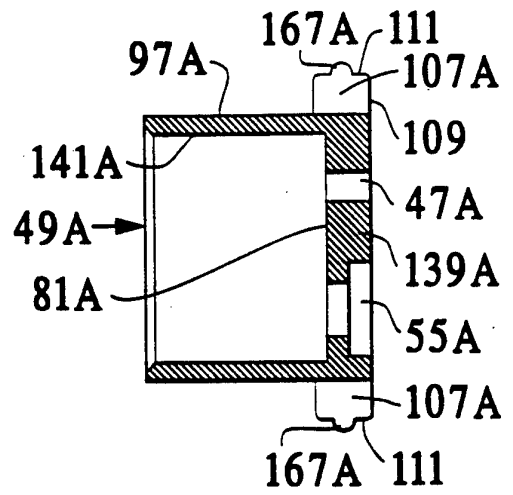

Fig. 12B

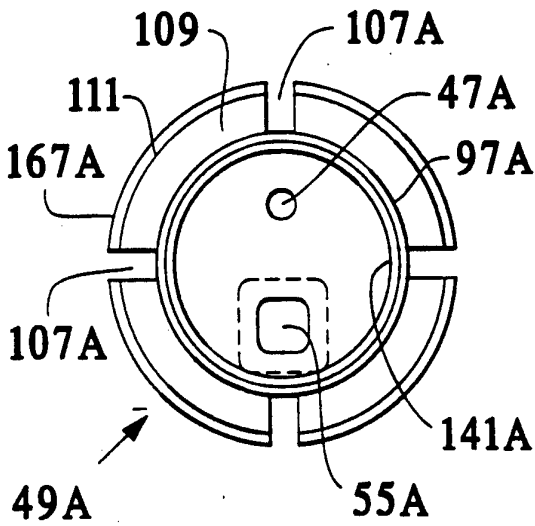

Fig. 12C

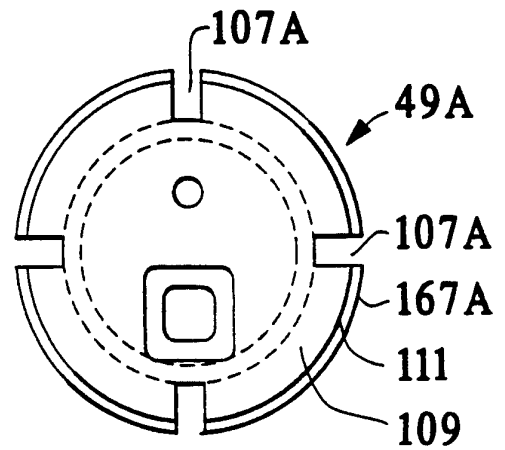

Fig. 12D

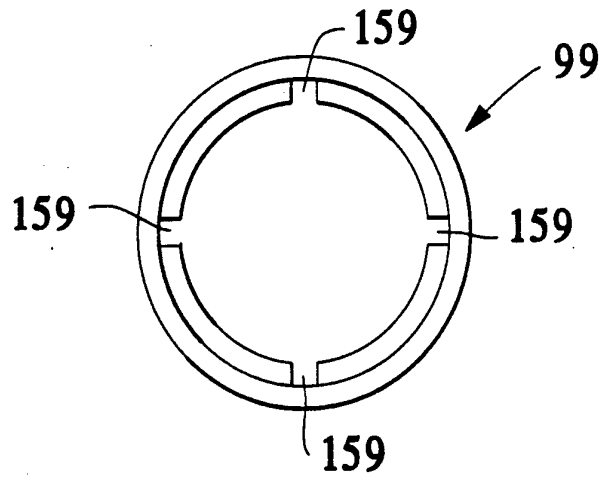

Fig. 13

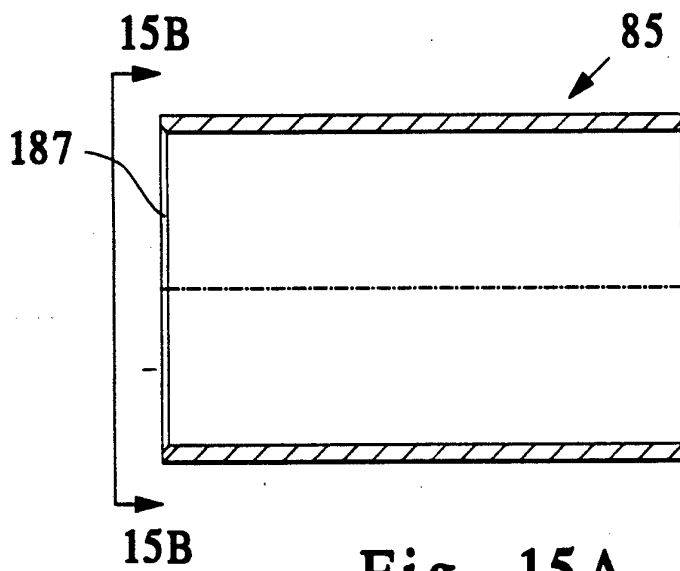

Fig. 15A

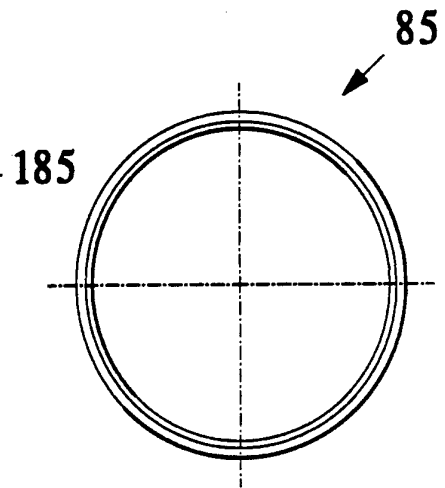

Fig. 15B

Fig.14A

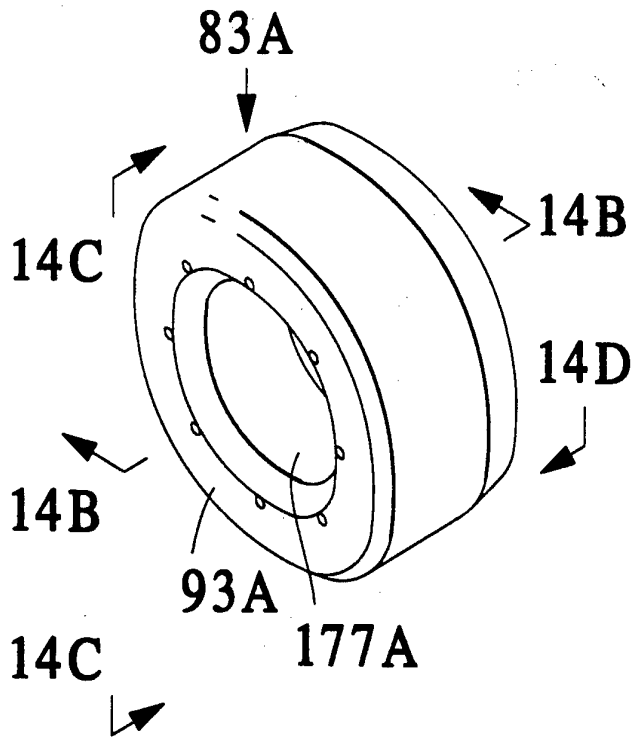

Fig.14B

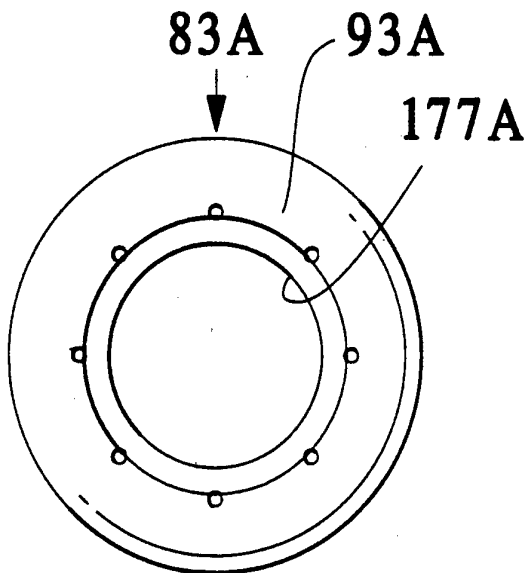
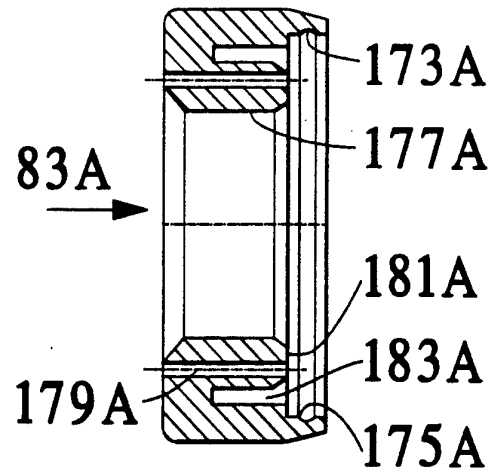

Fig.14C

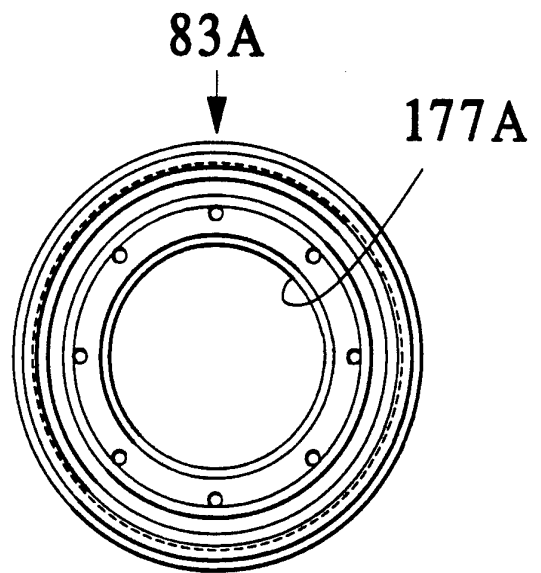

Fig.14D

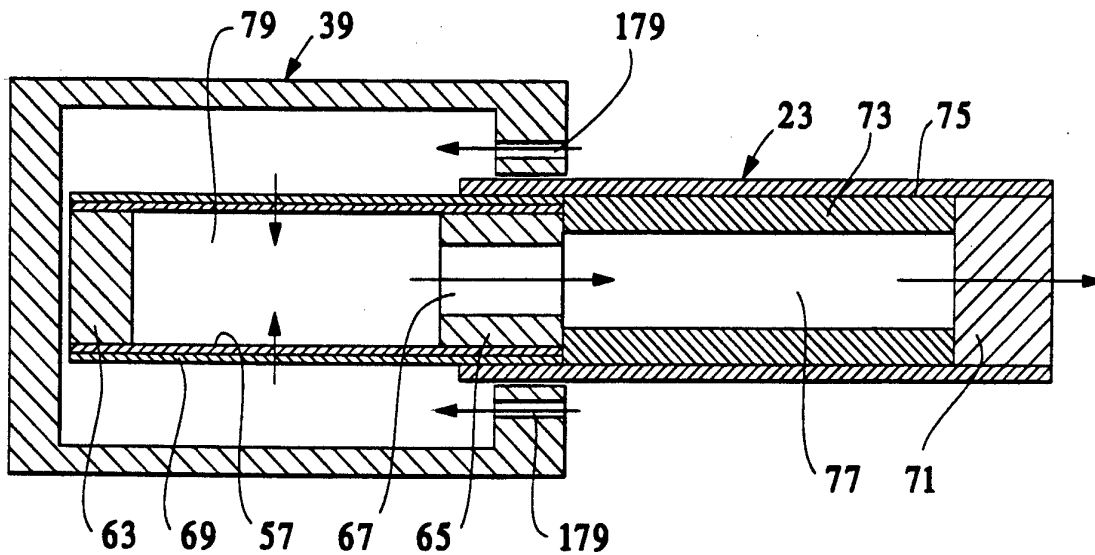

Fig. 16

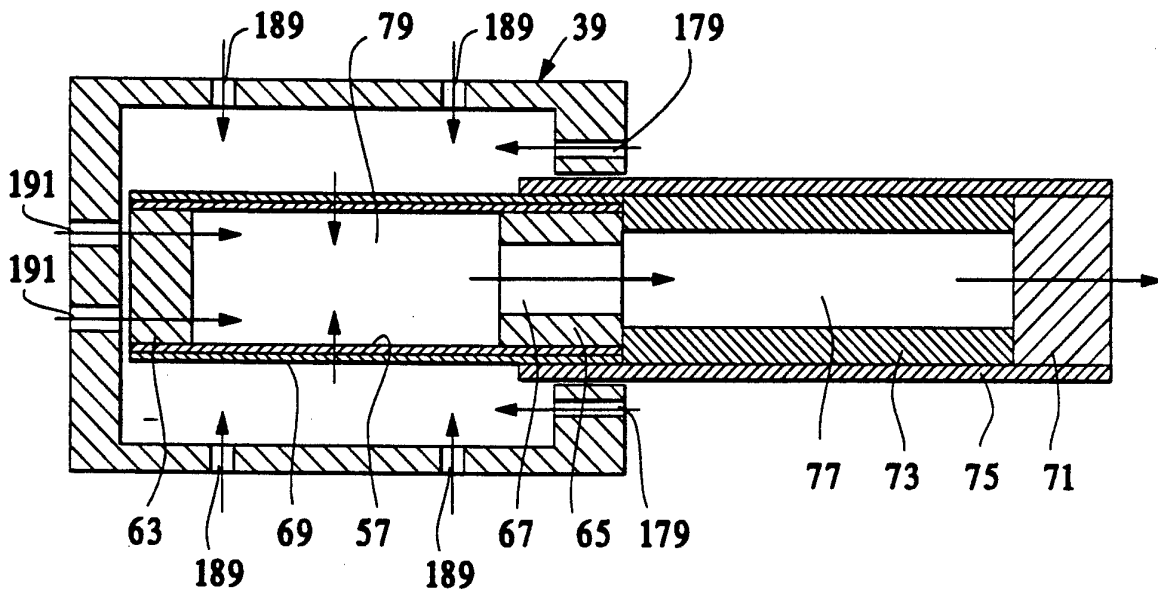
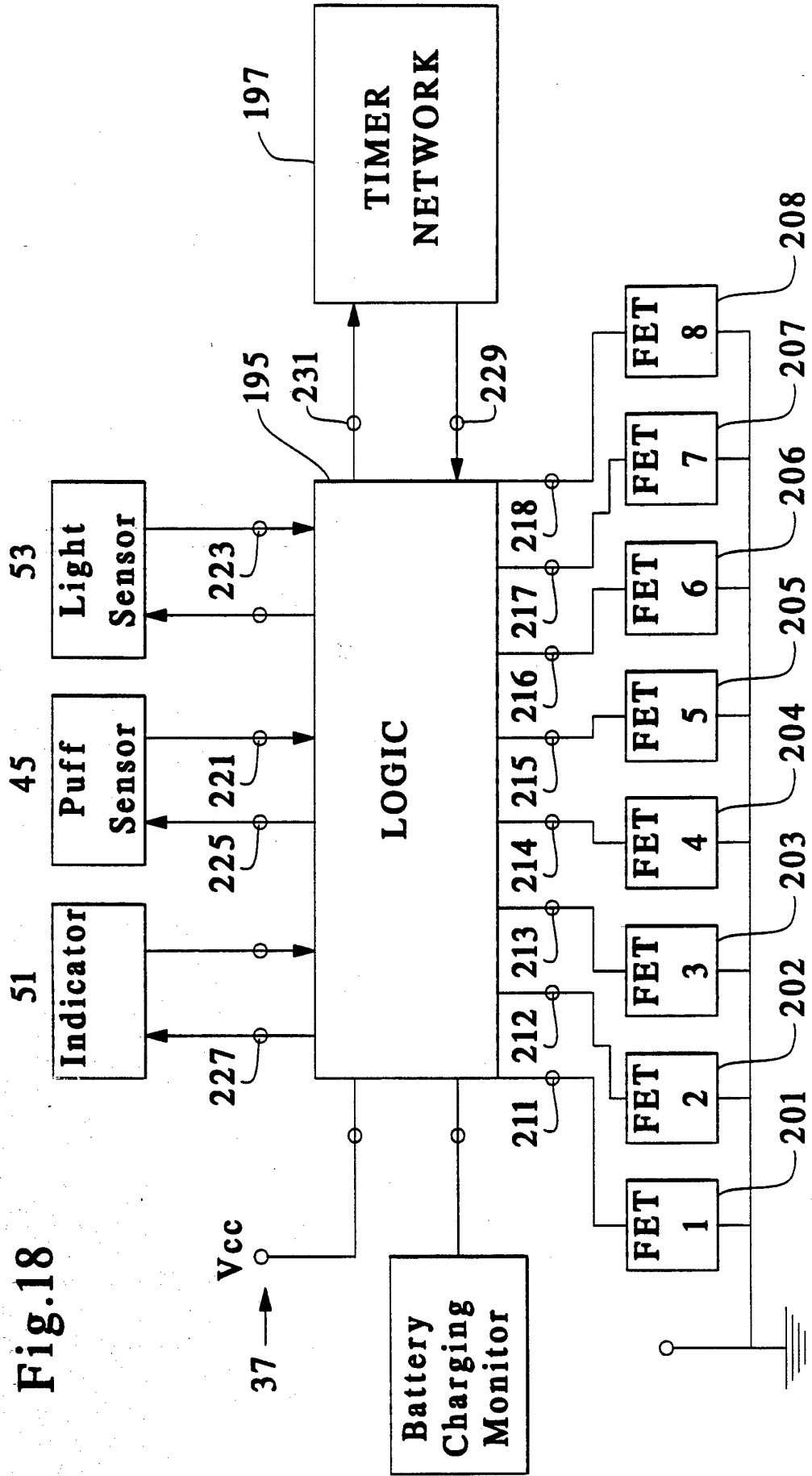

Fig. 17

Fig. 18



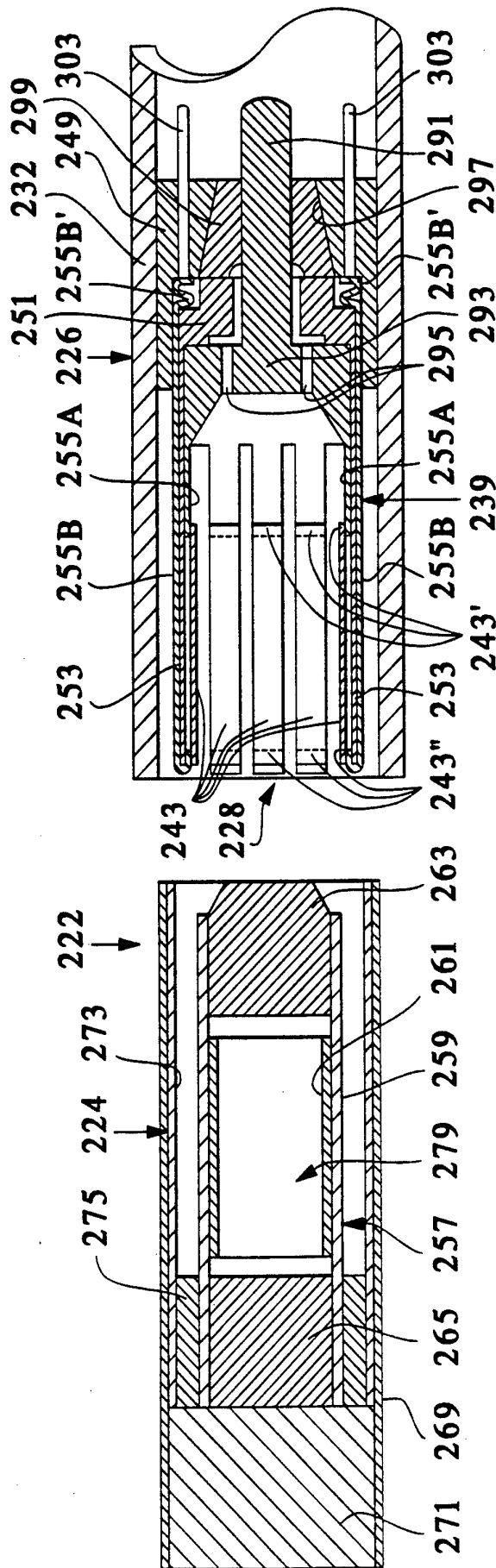

Fig. 19

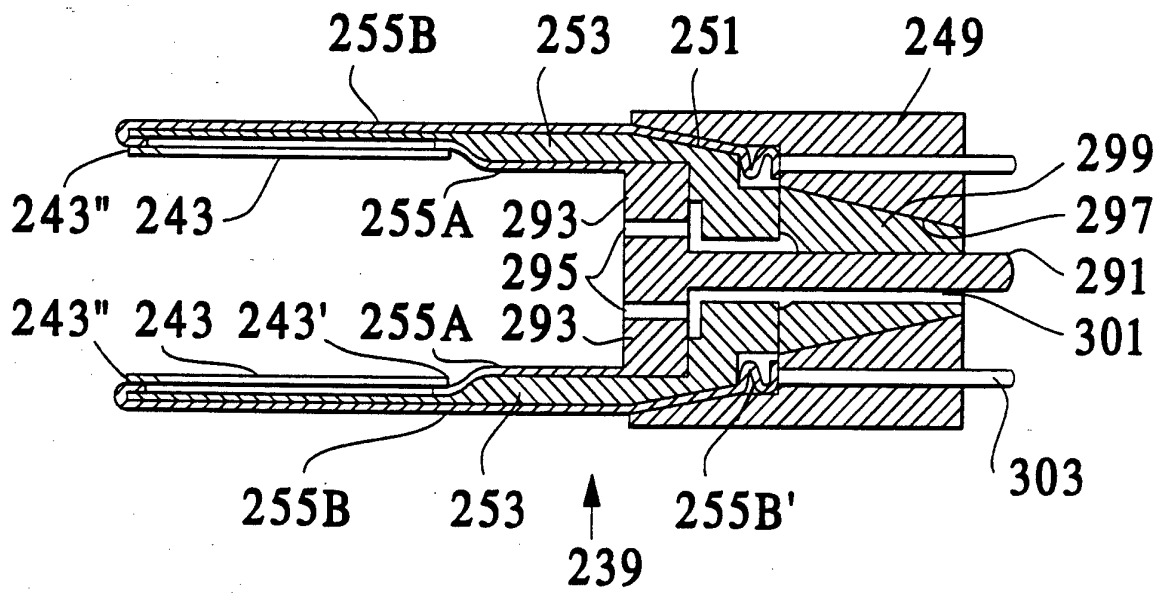

Fig. 20

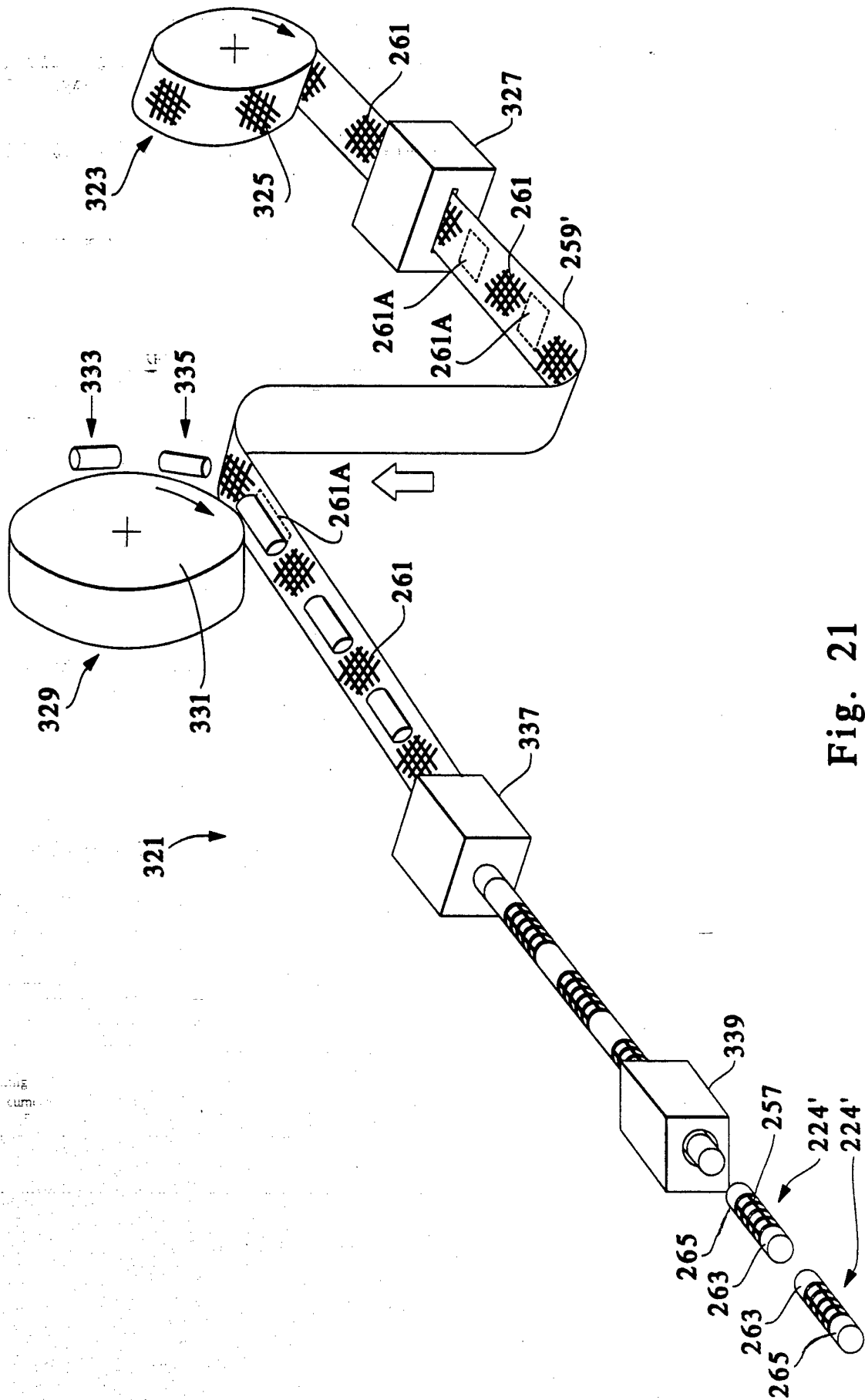

Fig. 21

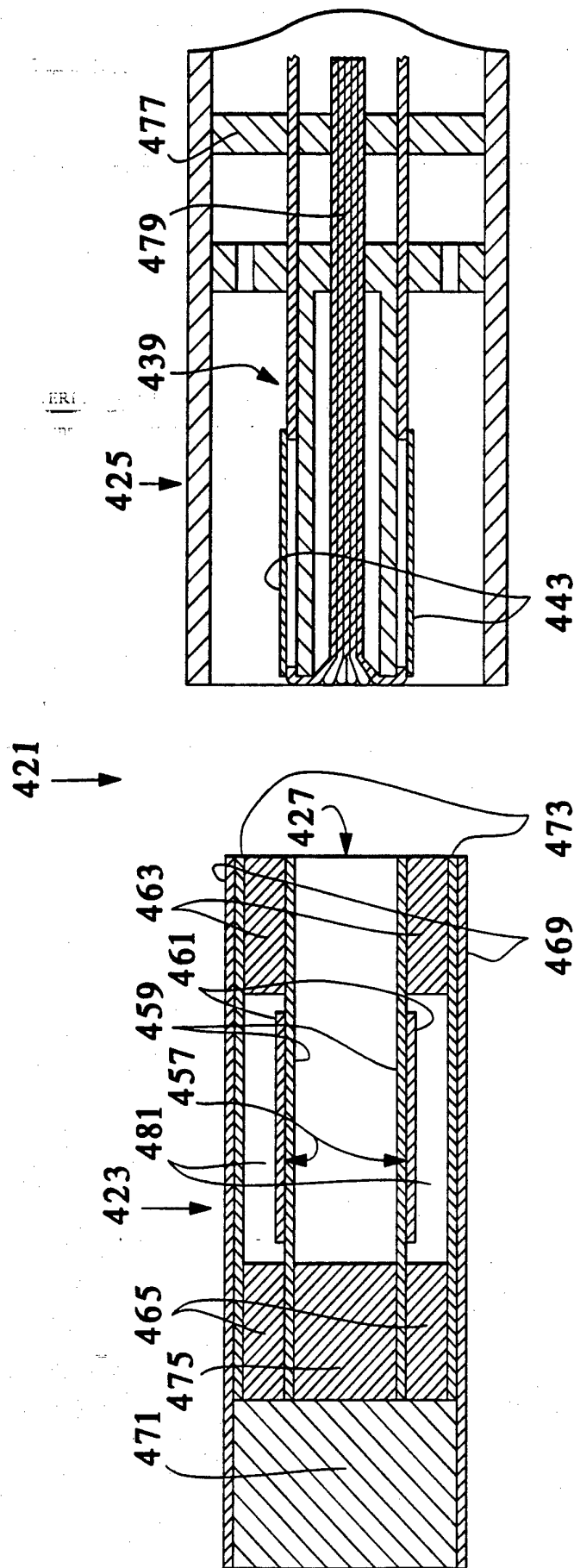

Fig. 22

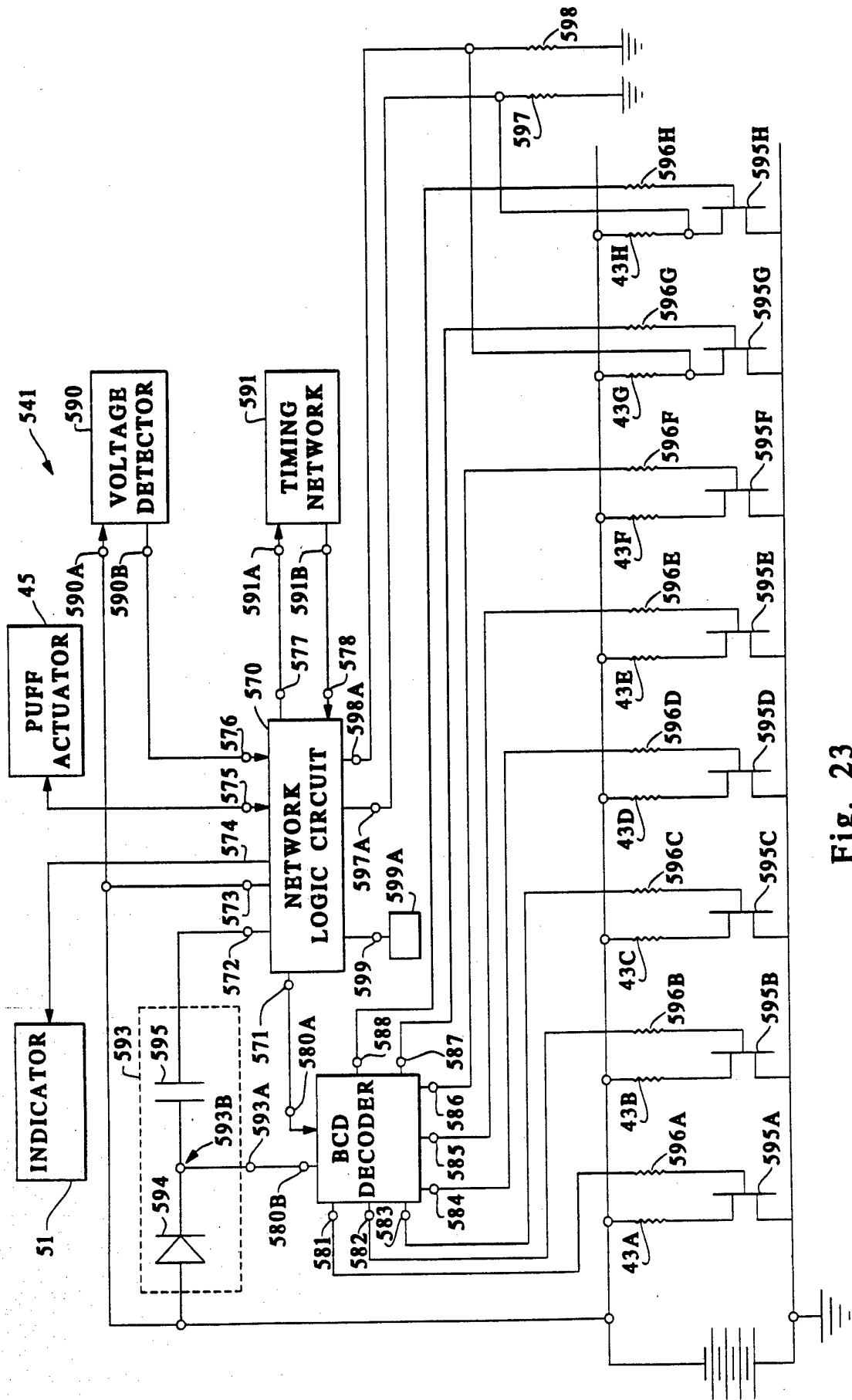

Fig. 23

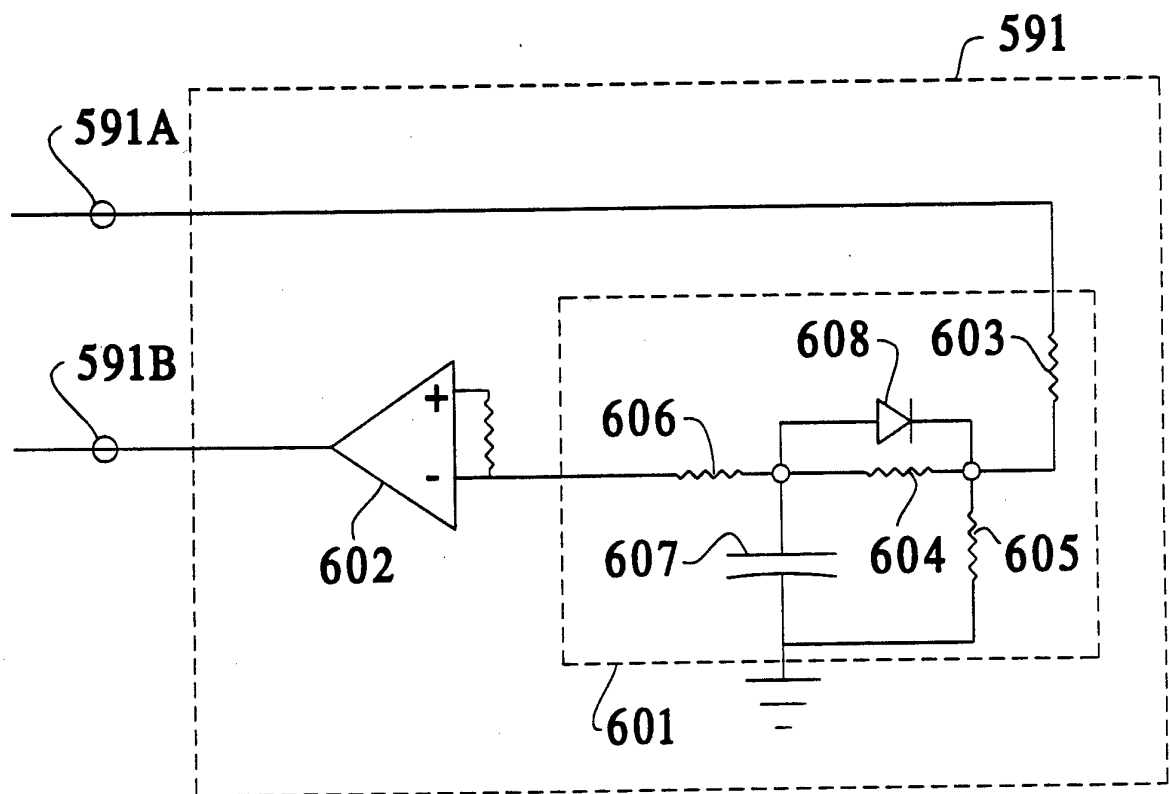

Fig. 24

INTERNATIONAL SEARCH REPORT

International application No.
PCT/US 93/08457

<p>A. CLASSIFICATION OF SUBJECT MATTER IPC 5 A24F47/00</p> <p>According to International Patent Classification (IPC) or to both national classification and IPC</p>								
<p>B. FIELDS SEARCHED</p> <p>Minimum documentation searched (classification system followed by classification symbols) IPC 5 A24F</p> <p>Documentation searched other than minimum documentation to the extent that such documents are included in the fields searched</p> <p>Electronic data base consulted during the international search (name of data base and, where practical, search terms used)</p>								
<p>C. DOCUMENTS CONSIDERED TO BE RELEVANT</p> <table border="1"> <thead> <tr> <th>Category *</th> <th>Citation of document, with indication, where appropriate, of the relevant passages</th> <th>Relevant to claim No.</th> </tr> </thead> <tbody> <tr> <td></td> <td style="text-align: center;">-/--</td> <td></td> </tr> </tbody> </table>			Category *	Citation of document, with indication, where appropriate, of the relevant passages	Relevant to claim No.		-/--	
Category *	Citation of document, with indication, where appropriate, of the relevant passages	Relevant to claim No.						
	-/--							
<p><input checked="" type="checkbox"/> Further documents are listed in the continuation of box C. <input checked="" type="checkbox"/> Patent family members are listed in annex.</p>								
<p>* Special categories of cited documents :</p> <p>"A" document defining the general state of the art which is not considered to be of particular relevance</p> <p>"E" earlier document but published on or after the international filing date</p> <p>"L" document which may throw doubts on priority claim(s) or which is cited to establish the publication date of another citation or other special reason (as specified)</p> <p>"O" document referring to an oral disclosure, use, exhibition or other means</p> <p>"P" document published prior to the international filing date but later than the priority date claimed</p> <p>"T" later document published after the international filing date or priority date and not in conflict with the application but cited to understand the principle or theory underlying the invention</p> <p>"X" document of particular relevance; the claimed invention cannot be considered novel or cannot be considered to involve an inventive step when the document is taken alone</p> <p>"Y" document of particular relevance; the claimed invention cannot be considered to involve an inventive step when the document is combined with one or more other such documents, such combination being obvious to a person skilled in the art.</p> <p>"&" document member of the same patent family</p>								
<p>Date of the actual completion of the international search</p> <p style="text-align: center;">15 December 1993</p>		<p>Date of mailing of the international search report</p> <p style="text-align: center;">20. 01. 94</p>						
<p>Name and mailing address of the ISA</p> <p>European Patent Office, P.B. 5818 Patentaan 2 NL - 2280 HV Rijswijk Tel. (+31-70) 340-2040, Tx. 31 651 epo nl, Fax (+31-70) 340-3016</p>		<p>Authorized officer</p> <p style="text-align: center;">Raven, P</p>						

INTERNATIONAL SEARCH REPORT

International application No.
PCT/US 93/08457

C.(Continuation) DOCUMENTS CONSIDERED TO BE RELEVANT		
Category*	Citation of document, with indication, where appropriate, of the relevant passages	Relevant to claim No.
P,X	EP,A,0 503 767 (PHILIP MORRIS PRODUCTS INC.) 16 September 1992	97,146, 159-161, 174
P,Y	see the whole document	1,2,8, 13-30, 41-55, 175-183, 188-196
P,A		3,5,6, 9-12,31, 33,34, 36-40, 56, 85-89, 91,92, 94-96, 99,103, 113,116, 117
P,A		147-158, 162-173, 206
	& US,A,5 249 586 (PHILIP MORRIS INC.) 5 October 1993 cited in the application	
Y	US,A,5 060 671 (COUNTS ET AL) 29 October 1991 cited in the application	1,2,8, 13-30, 41-55, 175-183, 188-196
	see the whole document	
A	US,A,5 144 962 (COUNTS ET AL) 8 September 1992 cited in the application	1,15,29, 85,87, 97,118, 146,161
	see the whole document	
A	EP,A,0 358 002 (R.J. REYNOLDS TOBACCO) 14 March 1990	1,15,29, 85,87, 97,146, 159-161
	see the whole document	
A	WO,A,86 02528 (NILSSON ET AL) 9 May 1986	1,15,29, 87,146
	see page 5, paragraph 5 - page 8; figures	
A	US,A,3 200 819 (H.A. GILBERT) 17 August 1965 see the whole document	1,15,29, 159-161

1

INTERNATIONAL SEARCH REPORT

Information on patent family members

International application No.

PCT/US 93/08457

Patent document cited in search report	Publication date	Patent family member(s)	Publication date
EP-A-0503767	16-09-92	AU-A- 1280292 JP-A- 5115272 US-A- 5249586	17-09-92 14-05-93 05-10-93
US-A-5249586	05-10-93	AU-A- 1280292 EP-A- 0503767 JP-A- 5115272	17-09-92 16-09-92 14-05-93
US-A-5060671	29-10-91	AU-B- 642448 AU-A- 6762290 CA-A- 2031227 EP-A- 0430566 JP-A- 3277265	21-10-93 06-06-91 02-06-91 05-06-91 09-12-91
US-A-5144962	08-09-92	AU-A- 6762090 CA-A- 2031225 EP-A- 0430559 JP-A- 3232481	06-06-91 02-06-91 05-06-91 16-10-91
EP-A-0358002	14-03-90	US-A- 4947874 CN-A- 1045691 JP-A- 2124082	14-08-90 03-10-90 11-05-90
WO-A-8602528	09-05-86	AU-A- 5015385 CA-A- 1259181 EP-A, B 0230420 JP-T- 62501050 US-A- 4848376 US-A- 4907606 US-A- 4776353	15-05-86 12-09-89 05-08-87 30-04-87 18-07-89 13-03-90 11-10-88
US-A-3200819		NONE	