

(No Model.)

3 Sheets—Sheet 1.

S. A. COONEY.
AUTOMATIC SWITCH.

No. 544,961.

Patented Aug. 20, 1895.

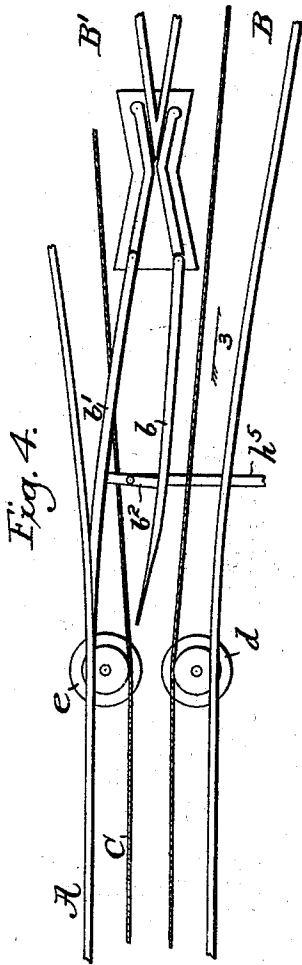

Fig. 4.

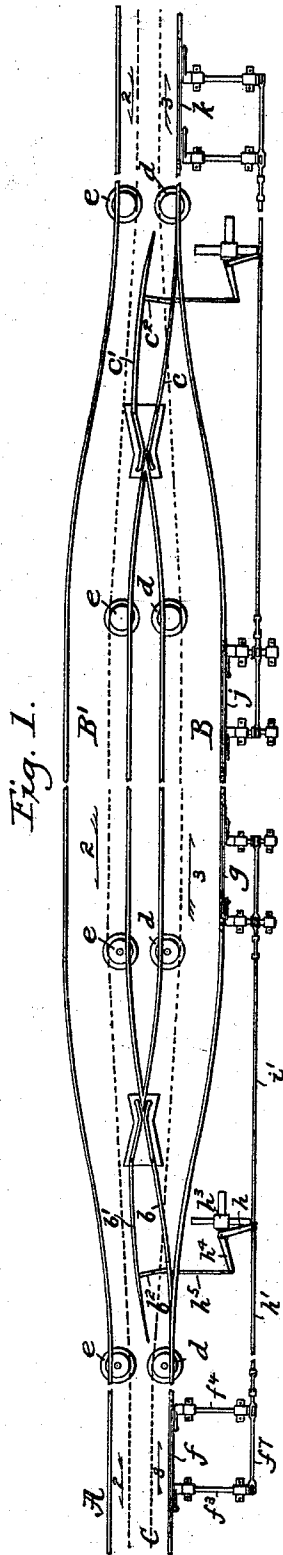

Fig. 1.

WITNESSES:

H. Graham
E. L. Todd

INVENTOR

Sebern A. Cooney

BY

Graham & Low
ATTORNEYS.

(No Model.)

3 Sheets—Sheet 2.

S. A. COONEY.
AUTOMATIC SWITCH.

No. 544,961.

Patented Aug. 20, 1895.

Fig. 2.

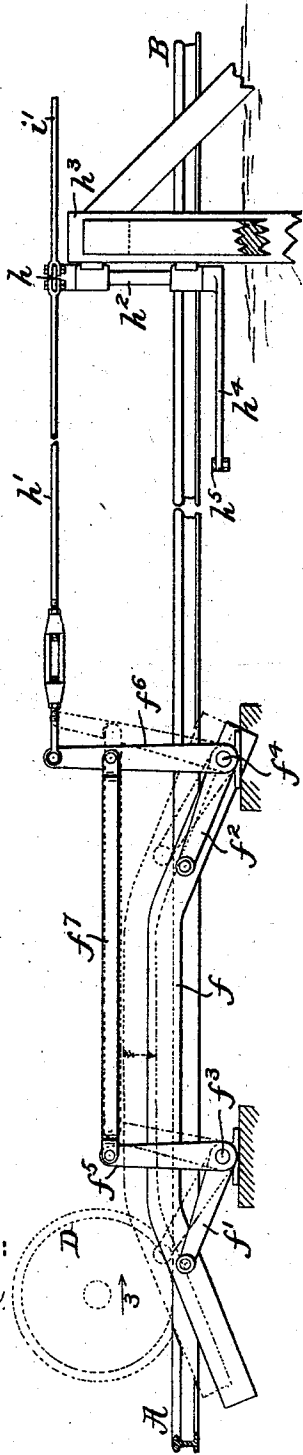
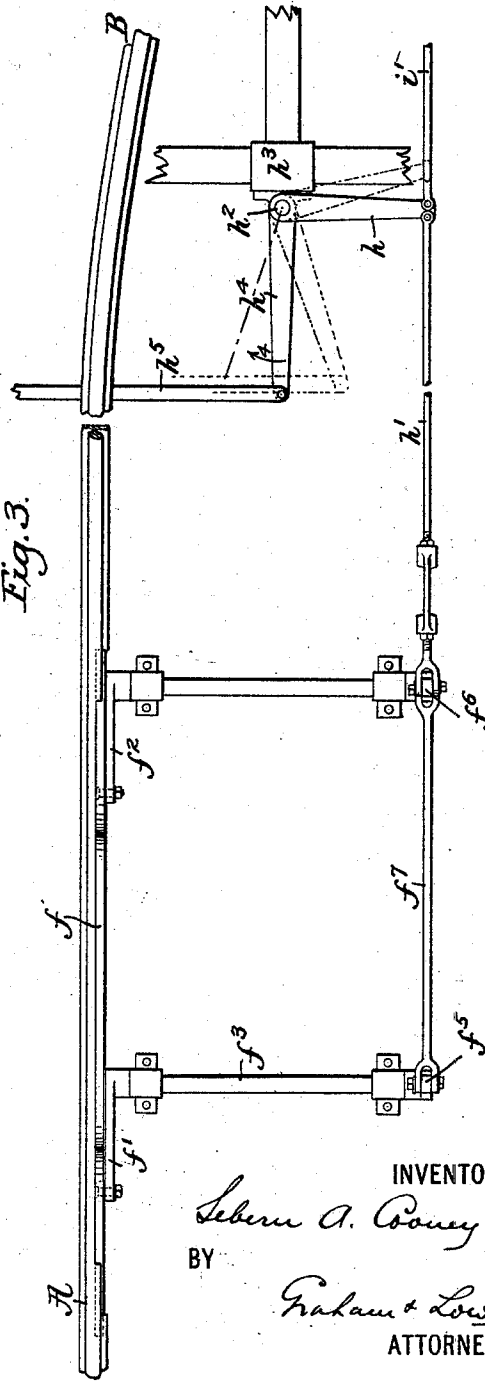

Fig. 3.



WITNESSES:
H. Graham.
C. L. Todd.

INVENTOR
S. A. Cooney
BY
Graham & Loe
ATTORNEYS.

(No Model.)

3 Sheets—Sheet 3.

S. A. COONEY.
AUTOMATIC SWITCH.

No. 544,961.

Patented Aug. 20, 1895.

Fig. 2^a

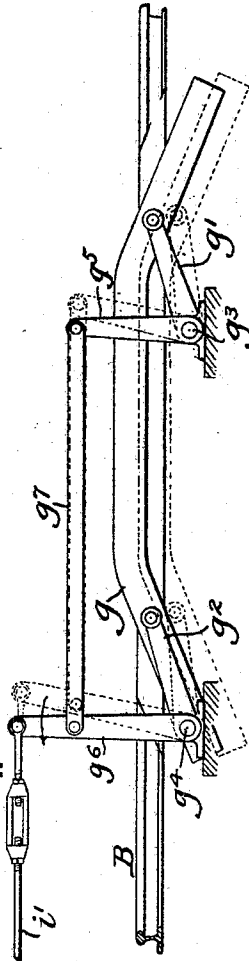

WITNESSES:
H. Graham
E. L. Todd

Fig. 3^a

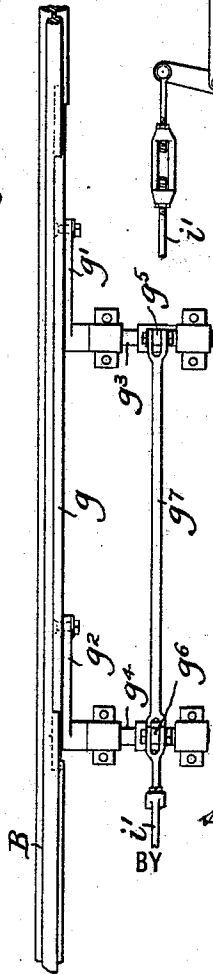
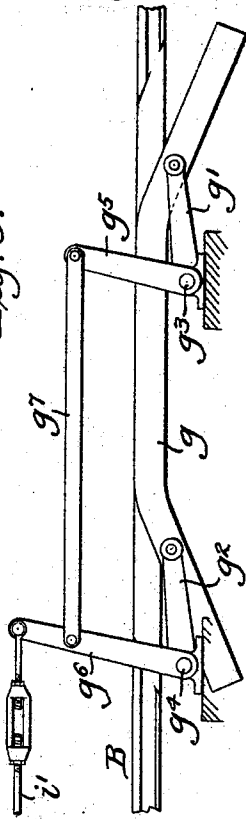

Fig. 5.



INVENTOR
Severn A. Cooney
 BY
Graham & Low,
 ATTORNEYS.

UNITED STATES PATENT OFFICE.

SEBERN A. COONEY, OF NEW YORK, N. Y., ASSIGNOR OF ONE-HALF TO THE JOHN A. ROEBLING'S SONS COMPANY, OF TRENTON, NEW JERSEY.

AUTOMATIC SWITCH.

SPECIFICATION forming part of Letters Patent No. 544,961, dated August 20, 1895.

Application filed August 9, 1894. Serial No. 519,900. (No model.)

To all whom it may concern:

Be it known that I, SEBERN A. COONEY, a citizen of the United States of America, residing in the city, county, and State of New York, have invented certain new and useful Improvements in Automatic Switches, of which the following is a specification.

This invention relates, generally, to tram or rail ways and more particularly to the means for automatically operating the switch in such ways by the movement of the passing car or truck, as by its wheel or by some contact-piece carried by the car.

The present invention is particularly applicable to tramways wherein the car or truck is drawn along the way in either or both directions by a cable and is to be directed onto a turn-out, switch, or branch track, and the automatic devices constituting the invention are adapted to set the switch in advance of the car, so that not only is the car properly guided onto the turn-out, switch, or branch track, but a clear space is left for the unobstructed movement of the connection between the car and cable.

As a better understanding of the invention will be had from a detailed description of the same, such description will now be given, reference being had to the accompanying drawings, which illustrate a practical embodiment of the invention in its preferred form.

In said drawings, Figure 1 is a diagram in plan of a tramway, consisting in the main of a single track provided intermediate of its length with a turn-out for the passage of cars or trucks going, for instance, in opposite directions, the improvements being shown in connection therewith. Figs. 2 and 2^a together show the automatic switch-operating devices in side elevation. Figs. 3 and 3^a show the same devices in plan. Figs. 4 and 5 are diagrams showing the parts in changed positions.

Referring to Fig. 1, the improvements are shown in connection with a single-track tramway A B, in which is interposed opposite the portion B of the single track a turn-out B', with movable switch-tongues *b b'* at one end of the turn-out and movable switch-tongues *c c'* at the other end of the turn-out, each of said two tongues being connected to-

gether, so as to move in unison in one case by a bar *b²* and in the other case by a bar *c²*. These switch-tongues are so arranged that the tongues *c* and *b* are in alignment with the rail of the tramway to direct a car going in the direction of the arrows 2 onto the turn-out B' and thence onto the straight track again, and the switch-tongues *b'* and *c'* are arranged when in alignment with the other rail of the tramway to direct a car going in the direction of the arrows 3 onto the turn-out B and then onto the straight track again. With the tramway there is associated a motor-cable C, one portion of which moves in the direction of the arrows 3 and is guided by the pulleys *d* to, along, and from the track portion B, and the other portion of which, moving in the direction of the arrows 2, is guided by pulleys *e* to, along, and from the turn-out B'. As shown in Fig. 1, the switch-tongues *c* and *b* are set to guide the car moving in the direction of the arrows 2 onto the turn-out B', and from said turn-out onto the straight portion of the track, and in these positions of the switch-tongues the other switch-tongues *c'* *b'* occupy in their inactive positions a point intermediate between the track-rails of the tramway, which will permit the unobstructed vertical movement of the cable or rope, which is then active in moving a car past the switch-tongues onto and from the turn-out B'. In like manner, as shown in Fig. 4, when the switch-tongues have been moved to direct the car onto the track portion B the idle tongue lying intermediate between the track-rails forms no obstruction to the free vertical movement of the cable or rope, which is gripped to the car passing onto the track portion B.

The means for setting the switch-tongues and at the same time moving them out of the path of the cable consists of a pair of contact-bars *f g*, arranged along parallel with one of the track-rails and preferably lying in a recess cut in the outer side of the track-rail, so as to be in position to be struck and operated by the car-wheel or other contact-piece D, Fig. 2, of the car moving along the track. In the normal position of the contact-bars *f g* the bar *f* extends above the surface of the track-rail, as shown in dotted lines, Fig. 2, and the bar *g* lies below the surface of the track-

rail, as indicated by dotted lines in Fig. 2^a, so that when the car-wheel passes over the bar *f* said bar will move downward level with the surface of the track-rail and the bar *g* will have been simultaneously raised above the surface of the track-rail.

The connections between each of the contact-bars and the switch-tongues are preferably all lever connections with the proper rigid connecting-rods, so that the movements of each contact-bar will be positively communicated with the switch-tongues and insure their proper movement, and the arrangement is also such that all the strains on the arms and rods are tensile strains, in contradistinction to torsional strains. Each contact-bar, also, is arranged to move vertically in parallel planes, and for this purpose the bar *f* is connected to the ends of two rock-arms *f'* *f*², that are secured to horizontal rock-shafts *f*³ *f*⁴, mounted in suitable bearings that are supported in fixed position along the sides of the tramway. The rock-shafts *f*³ *f*⁴ are provided with vertically-arranged arms *f*⁵ *f*⁶, which are joined together by a connecting-rod *f*⁷, so that the rock-shafts and the rock-arms move in unison. The vertical arm *f*⁶ is somewhat longer than the other arm *f*⁵ and at its extreme end it is connected by a connecting-rod *h'*, having an adjusting turn-buckle intermediate of its length, with a rock-arm *h* mounted and fixed to the upper end of a vertical rock-shaft *h*², which rock-shaft is mounted in suitable bearings secured to a vertical post *h*³. The lower end of the rock-shaft *h*² carries an arm *h*⁴, which, by a rod *h*⁵, is connected to the tie-bar *b*², that couples the switch-tongues *b* *b'* together.

Assuming that the parts stand in the position shown by dotted lines in Figs. 2 and 2^a, and that the switch-tongues *b* *b'* occupy the position shown in Fig. 1 and the car is moving along the track in the direction of the arrows 3, the car-wheel D, or other suitable contact carried by the car, will meet and pass over the contact-bar *f* and move it downwardly, and in so doing will have simultaneously rocked the arms *f'* *f*² and *f*⁵ *f*⁶, which, through the connecting-rod *h'*, will have rocked the arms *h* and *h*⁴ in the direction of the arrows 4, and will have thereby moved the switch-tongues *b* *b'* from the position shown in Fig. 1 into the position shown in Fig. 4, ready to direct the car from the track A onto the turnout B. The other contact and co-operating bar *g* along the turn-out B occupies a similar position with respect to the car-wheel or other contact D, and like the contact-bar *f* is connected to the ends of two rock-arms *g'* *g*², which are fast to rock-shafts *g*³ *g*⁴, each of which rock-shafts have arms *g*⁵ *g*⁶, connected by the connecting-bar *g*⁷, and the arm *g*⁶, longer than the arm *g*⁵, is connected by a connecting-rod *i'* to the same rock-arm *h* that the connecting-rod *h'* is fast to, so that whatever movement is imparted by the car-contact to the contact-bar *f* will be imparted to

the contact-bar *g*, such movement, however, of the contact-bar *g* being in a direction the reverse of the movement of the bar *f*—that is to say, that while the two bars in their normal condition occupy one an up position above the track and the other a down position below the track, when the bar *f* is moved downward the motion communicated from said bar to the bar *g* will be such as to raise the bar *g*. As soon as the car is on the turnout B and no part of that vehicle or the cars which may be in train therewith is on the switch-tongue the car-contact or wheel D will strike the contact-bar *g* and move it downward, which, through the connections described, will cause the rock-arms *h* and *h*⁴ to rock backward in the opposite direction to the arrows 4 and have moved the switch-tongues back into the position shown in Fig. 1, and will at the same time have raised the contact-bar *f* back to its raised position ready to be operated upon by the succeeding car, for a similar purpose as before. The switch-tongues *b* *b'* will have thus been set in position to permit the car on the turn out B' moving in the opposite direction to pass therefrom onto the straight track A. In the movement of these switch-tongues from the position shown in Fig. 1, where the switch-tongue *b* overlies one limb or portion of the cable C, said switch-tongue is moved to one side of the cable, so that there is a free passage for said cable when moved vertically from its normal down position under the strain of the approaching car to which it is connected. Such movement of the switch-tongue may also leave a free passage for the cable-grip of the car passing onto the track portion B. On the return of the switch-tongues to their normal positions, as shown in Fig. 1, the switch-tongue *b'* is likewise moved from obstructing the other limb or portion of the cable C, so that it is free to have vertical motion and the passage of the car-grip will be unobstructed. The other switch-tongues *c* *c'* also normally lie in the position so that the switch-tongue *c* will aid in directing the car moving in the direction of the arrows 2 onto the turnout B', and hence it is necessary to provide similar automatic switch-moving mechanism to move the switch-tongues into position so as to direct the car from the track portion B onto the straight portion of the track, and when on the straight portion of the track to return the switch-tongues to their normal position ready for the return movement of the car onto the turn-out B'. For this purpose the automatic mechanism, including the contact-bars *f* and *g* previously described, are duplicated, one contact-bar *j*, corresponding to the bar *f*, being located along the track portion B and another contact-bar *k*, similar to the contact-bar *g*, arranged beyond the switch-tongues *c* *c'* along the straight portion of the track. The construction and operation of these contact-bars *j* and *k* and their connections with the switch-tongues *c* *c'* are the same as previously described in relation to the bars

f and *g*, and hence further detailed description thereof is unnecessary. It may be stated, however, that the car passing along the track portion B in the direction of the arrows 3 will, through its contact or wheel D, move the bar *j* downwardly, and will thus have rocked the switch-tongues *c c'* over from the position shown in Fig. 1 into a position placing the tongue *c'* in alignment with the rail of the straight track, so that the car is directed from the turn-out onto the straight track, and will at the same time have moved the tongue *c* to one side of that portion of the cable moving in the direction of the arrows 3, so as to leave an unobstructed space for its movement and it may be of the grip. As soon as the car gets onto the straight portion of the track its contact or wheel D meets the other contact-bar *k* and rocks the switch-tongues back to their normal position, at the same time returning the bar *j* to its raised position ready to be met and operated by the contact of the succeeding car passing along the track portion B.

The different movements of the switches or switch-tongues have occurred during the movement of the car traveling in the direction of the arrows 3, and such a car in mining or quarrying operations will preferably be the loaded car traveling from the mine, tunnel, or shaft to the works or dump. The other car or cars moving in the opposite direction along the track, and usually light or empty, will have no service to perform, the switches having returned to their normal positions ready to properly guide such car onto the turn-out B', and thence onto the straight portion of the track.

The arrangement of switch-tongues described is peculiarly applicable to a tramway in which two turn-outs are interposed in a single line of track; but it is obvious that where the turn-out is simply a branch leading in another direction and not merging to the straight track again that a different arrangement of switch-tongues may be used, and hence it is to be understood that the invention is not limited to the use of two switch-tongues moving in unison. Neither is it limited to the duplication of mechanism for operating two sets of switch-tongues described. Neither

is it limited for use in a tramway employing a motor-cable.

What is claimed is—

1. In an automatic cable railway switch, the combination of a track, a turn-out or branch, a cable extending between the rails of the track and of the turn-out, a movable switch tongue at the junction of the track and turn-out, situated at a higher level than the cable and movable over or away from over the same, and automatic mechanism whereby the car may remove the overlying tongue from over the cable to permit the passage of the car, substantially as set forth.

2. In an automatic cable railway switch, the combination of a single track, a turnout, a cable having both limbs extending between the rails of said track at each side of the turnout and opposite the latter having one limb between the rails of the track and the other between the rails of the turnout, movable switch tongues at the ends of the turnout situated at a higher level than the cable and overlying one or the other limb of the cable, and automatic mechanism operated by the car and connected with said tongues, whereby the car may remove the overlying tongue from that limb of the cable with which the car is joined, substantially as set forth.

3. In an automatic cable railway switch the combination with the main track and a turn-out, of a cable having one limb extending between the rails of the track and the other limb extending between the rails of a portion of the track and between the rails of said turnout, movable switch tongues *b b'* at the end of the turnout overlying one or the other limb of the cable, a connection as *h³*, below the cable and joined to said tongues, and means whereby the car may operate said connection to expose the cable, substantially as set forth.

In witness whereof I have hereunto signed my name in the presence of two witnesses.

SEBERN A. COONEY.

Witnesses:

GEO. H. GRAHAM,
W. H. GRAHAM.