

April 18, 1961

S. H. A. THOMPSON

2,980,166

ADJUSTABLE BACK RESTS FOR SEATS

Filed July 9, 1959

Fig. 1.

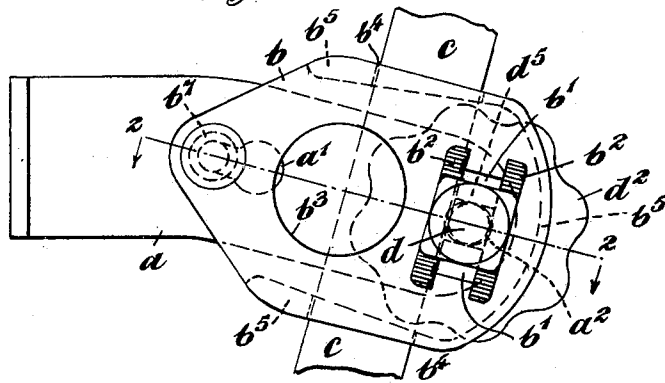

Fig. 2.

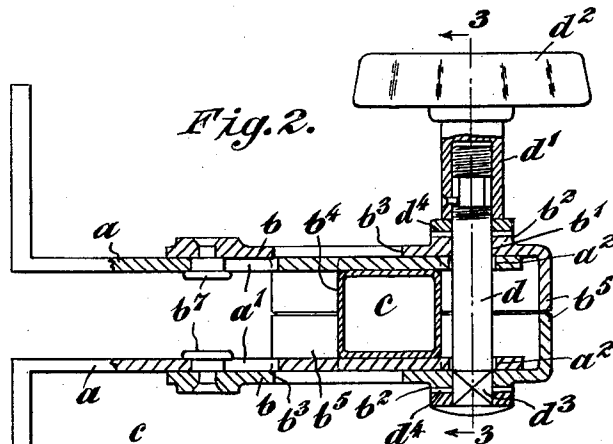

Fig. 3.

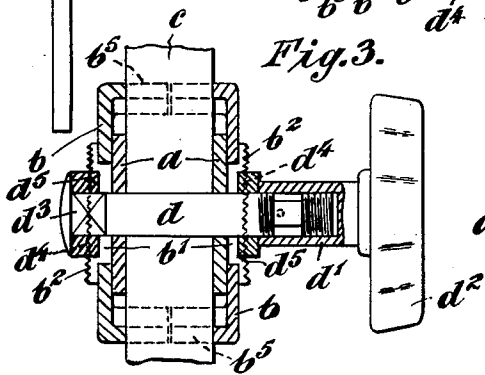
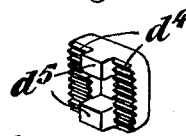

Fig. 4.



1

2,980,166

ADJUSTABLE BACK RESTS FOR SEATS

Stanley Howard Adcock Thompson, Stoke Bishop, Bristol, England, assignor to The Tan-Sad Chair Company (1931) Limited, Birmingham, England, a British company

Filed July 9, 1959, Ser. No. 825,979

3 Claims. (Cl. 155—157)

The present invention has relation to adjustable back rests for seats and has for its object the provision of a clamp carried by the seat proper through which clamp the back rest tube or member passes, the said clamp being readily operative by hand to admit of the vertical and oscillatory or angular adjustment of the supporting arm so that the actual back rest carried by the supporting arm can be brought into the desired position and fixed for the user, usually the small of the back.

According to the present invention complementary sockets are pivoted to rearward extensions of the seat between which extensions and sockets the back rest supporting tube is adjustably clamped by means of a hand screw member engaging both extensions and sockets on the remote side of the back rest supporting tube to that of the pivots, the said hand screw member being operatively located in bearings in the rearward extensions and having or carrying serrated members co-operative with serrations on the sockets and which lie adjacent to slots in the sockets permitting pivotal movement of the sockets in relation to the rearward extensions for the adjustment of the back rest support.

In order that the invention may be clearly understood and readily carried into practice reference may be had to the appended explanatory drawings in which:

Figure 1 illustrates the back rest supporting clamp in elevation.

Figure 2 is a sectional plan view taken on the line 2—2 of Figure 1.

Figure 3 is a vertical sectional elevation taken on the line 3—3 of Figure 2 and

Figure 4 is a perspective of a serrated plug hereinafter referred to.

In a convenient embodiment of the present invention the seat is provided at its rear with two protruding parallel plate-like members *a* to which the socket parts *b* of the clamp are pivoted and between which parts the tubular back rest *c* is adapted to slidably operate and be tilted. The clamp *b* is of a two-part character each part having a stud *b*⁷ at its forepart engageable with a key hole slot *a*¹ and at its rear part there is provided an elongated slot *b*¹ having parallel serrated parts *b*². A circular aperture *b*³ is provided in the centre and each half *b* on its inner face has a socket section *b*⁴ formed by gaps in a flange or part *b*⁵ to receive the tubular supporting stem *c* of more or less square section with rounded corners. A two-part hand screw is provided and this is installed in a loose bearing *a*² in the extremity of the rearwardly protruding plates *a* before referred to and one part *d* of this hand screw screws into the complementary part *d*¹ with handle *d*² and is arrested against rotation at *d*³. *d*⁴ is a serrated plate with dog teeth *d*⁵ mounted at two positions on *d* the dog teeth *d*⁵ engaging the slots *b*¹ in *b* to arrest rotation and the serrations on *d*⁴ cooperate with *b*² on *b*. It will be appreciated that by releasing this duplex clamp by unscrewing *d*¹ from *d* not only is the tube supporting arm enabled to be slid vertically or substantially vertically but the arm *b* may be

2

moved on its pivots *b*⁷ by virtue of the elongated slots *b*¹ engaging the clamping screw which remains substantially stationary so that a small universal setting of the back rest supported by the supporting arm is rendered possible in a given plane. Tightening of the hand screw secures all parts in the position of adjustment.

I claim:

1. In a device for so supporting a back rest relative to a chair seat that the back rest can be adjusted up and down and angularly forward and back, and conveniently and safely clamped in adjusted position, in combination, a pair of substantially parallel plate-like extensions projecting rearwardly and capable of being sprung toward each other, a bolt passing through said plate-like extensions, socket parts lying against the outsides of said plate-like extensions, pivots connecting the forward ends of said socket parts to said extensions, said socket parts having slots through which said bolt passes, whereby the position of said bolt is unchanged when said socket parts are swung about the said pivots, said socket parts having flanges that overlie and underlie edges of said plate-like extensions and overlie and underlie space between said plate-like extensions, the said flanges being notched to receive a back rest stem, a flat-sided back rest stem received by said notched flanges and longitudinally adjustable relative thereto, washers on said bolt, said washers and said socket parts having interengaging rugations, and a hand operated nut member threaded upon said bolt, whereby when said hand operated nut member is turned back engagement of said rugations is loosened and clamping of said socket parts upon said plate-like extensions and clamping of said extensions upon said flat-sided back rest stem are relieved to permit the stem to be adjusted longitudinally and tilted forwardly or backwardly while the position of the hand operated nut remains unchanged and whereby when the hand operated nut is turned up the elements are safely secured together.

2. In a device for so supporting a back rest relative to a chair seat that the back rest can be adjusted up and down and angularly forward and back, and conveniently and safely clamped in adjusted position, in combination, a pair of substantially parallel plate-like extensions projecting rearwardly and capable of being sprung toward each other, a bolt passing through said plate-like extensions, socket parts lying against the outsides of said plate-like extensions, pivots connecting the forward ends of said socket parts to said extensions, means whereby the position of said bolt is unchanged when said socket parts are swung about the said pivots, said socket parts having means to receive a back rest stem, a flat-sided back rest stem received by said means and longitudinally adjustable relative thereto, washers on said bolt, said washers and said socket parts having interengaging rugations, and a hand operated nut member threaded upon said bolt, whereby when said hand operated nut member is turned back engagement of said rugations is loosened and clamping of said socket parts upon said plate-like extensions and clamping of said extensions upon said flat-sided back rest stem are relieved to permit the stem to be adjusted longitudinally and tilted forwardly or backwardly while the position of the hand operated nut remains unchanged and whereby when the hand operated nut is turned up the elements are safely secured together.

3. In a device for so supporting a back rest relative to a chair seat that the back rest can be adjusted up and down and angularly forward and back, and conveniently and safely clamped in adjusted position, in combination, a pair of substantially parallel plate-like extensions projecting rearwardly and capable of being sprung toward each other, a bolt passing through said plate-like extensions, socket parts lying against the outsides of said plate-like extensions, pivots connecting the forward ends

3

of said socket parts to said extensions, means whereby the position of said bolt is unchanged when said socket parts are swung about the said pivots, said socket parts having means to receive a back rest stem, a flat-sided back rest stem received by said means and longitudinally adjustable relative thereto, and a hand operated nut member threaded upon said bolt, whereby when said hand operated nut member is turned back clamping of said socket parts upon said plate-like extensions and clamping of said extensions upon said flat-sided back rest stem are relieved to permit the stem to be adjusted longitudinally

4

and tilted forwardly or backwardly while the position of the hand operated nut remains unchanged and whereby when the hand operated nut is turned up the elements are safely secured together.

References Cited in the file of this patent

UNITED STATES PATENTS

2,043,433	Gabb	June 9, 1936
2,565,867	Lundquist	Aug. 28, 1951