

H. FRANK.

Regenerative Furnace-Valves.

No. 134,370.

Patented Dec. 31, 1872.

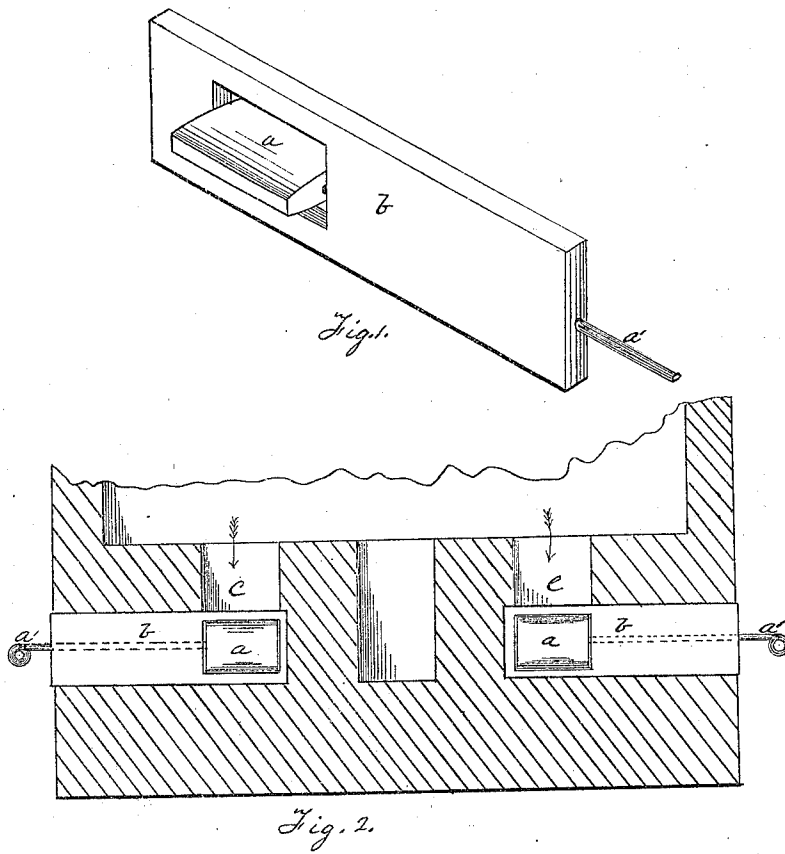

WITNESSES.  
James L. Kay  
E. C. Titler.

INVENTOR:  
Hiram Frank  
By Rowell, Childs & Ken  
His Attorneys

# UNITED STATES PATENT OFFICE.

HIMAN FRANK, OF PITTSBURG, PENNSYLVANIA.

## IMPROVEMENT IN REGENERATIVE-FURNACE VALVES.

Specification forming part of Letters Patent No. 134,370, dated December 31, 1972.

*To all whom it may concern:*

Be it known that I, HIMAN FRANK, of Pittsburg, in the county of Allegheny and State of Pennsylvania, have invented a new and useful Improvement in Valves for Regenerative Furnaces; and I do hereby declare the following to be a full, clear, and exact description thereof, reference being had to the accompanying drawing forming part of this specification, in which—

Figure 1 is a perspective view of my improved valve and seat; and Fig. 2, by a sectional view, illustrates its application to the flues of a furnace.

Like letters of reference indicate like parts in each.

My invention relates to that class of metallurgic and other furnaces in which gas and air form the elements of combustion. For many purposes it is necessary to regulate the amount of gas and air admitted into the furnace. In order to accomplish this many different arrangements of valves and flues have been made, but with only partial success, or at the expense of simplicity in the construction and operation of the furnace. My invention consists in making a valve which is placed in a removable seat and operated in the manner hereinafter described to open, close, enlarge, or reduce the gas and air flues at the will of the operator.

To enable others skilled in the art to make and use my invention, I will describe its construction and operation.

The valve *a*, which is what is known as a "butterfly" valve, is set in a movable seat or frame, *b*, and is operated by means of the handle *a'*. This valve-seat is inserted into the walls of the furnace by a slot or opening of corresponding shape, so as to bring the valve *a* directly across the air or gas flue leading to the furnace. Fig. 2 shows the valve applied to the flues of a regenerative furnace. The air is led by suitable flues, into the flue *c* from the

lower end of which the flue leads directly back. The valve *a* stands directly across the mouth of the latter flue and governs the admission of air into it from the flue *c*. A similar valve, *a*, is arranged in the gas-flue *e* and operates in precisely the same manner.

The valve-frame *b* is made removable, because the valve, when placed where it is subject to great heat, may become warped, and thereby be rendered inoperative. In such case it is desirable to remove the valve without stopping or interfering with the operation of the furnace. This is done by removing the valve-frame *b* and immediately inserting in its place another valve and frame of like construction. This operation has been impossible heretofore, and is of great importance, for a whole "heat" would otherwise be lost.

These valves may be placed at any suitable and desired point in the flues of a furnace.

By means of the handles *a'* the operator or furnace-man can regulate the flow of the air and gas into the furnace, and, if desired, by means of a similar valve placed in the flue to the stack, the draft of the furnace.

What I claim as my invention, and desire to secure by Letters Patent, is—

1. The valve *a*, set in a removable frame, *b*, and operated by the handle *a'*, substantially as described, and for the purposes set forth.

2. The valve *a* with its removable seat *b* and handle *a'*, in combination with the gas and air flues of a furnace, or either of them, and so arranged relatively thereto, substantially as described, that the aerial and gaseous currents or either of them can be regulated at the will of the operator.

In testimony whereof I, the said HIMAN FRANK, have hereunto set my hand.

HIMAN FRANK.

Witnesses:

A. S. NICHOLSON,  
THOS. B. KERR.