

(19)



(11)

EP 3 820 159 B1

(12)

EUROPEAN PATENT SPECIFICATION

(45) Date of publication and mention of the grant of the patent:
21.06.2023 Bulletin 2023/25

(51) International Patent Classification (IPC):
H04R 1/26^(2006.01) H04R 1/28^(2006.01)

(21) Application number: **20204192.7**

(52) Cooperative Patent Classification (CPC):
H04R 1/26; H04R 1/2888; H04R 1/24; H04R 1/2811; H04R 2201/02

(22) Date of filing: **27.10.2020**

(54) **ACOUSTIC SPEAKER**

LAUTSPRECHER

HAUTPARLEUR

(84) Designated Contracting States:
AL AT BE BG CH CY CZ DE DK EE ES FI FR GB GR HR HU IE IS IT LI LT LU LV MC MK MT NL NO PL PT RO RS SE SI SK SM TR

(72) Inventor: **Perrini, Matteo**
96018 Pachino (SR) (IT)

(30) Priority: **08.11.2019 IT 201900020664**

(74) Representative: **Santi, Filippo et al**
Barzanò & Zanardo Roma S.p.A.
Via Piemonte 26
00187 Roma (IT)

(43) Date of publication of application:
12.05.2021 Bulletin 2021/19

(56) References cited:
EP-A1- 0 521 655 GB-A- 1 303 602
US-A1- 2010 177 921 US-A1- 2012 195 447
US-B1- 8 967 323

(73) Proprietor: **Perrini, Matteo**
96018 Pachino (SR) (IT)

EP 3 820 159 B1

Note: Within nine months of the publication of the mention of the grant of the European patent in the European Patent Bulletin, any person may give notice to the European Patent Office of opposition to that patent, in accordance with the Implementing Regulations. Notice of opposition shall not be deemed to have been filed until the opposition fee has been paid. (Art. 99(1) European Patent Convention).

Description

[0001] This invention relates to an acoustic speaker.

5 **Technical field**

[0002] More in detail, the invention relates to an acoustic speaker designed and produced in particular to optimise the reproduction of audio signals, improving the sound perception of the audio signals by users.

10 [0003] The following description will relate to musical reproduction but it is evident that it must not be considered to be limited to that specific use.

Background art

15 [0004] As is known, there has been an increased interest in recent years from users in the reproduction of high-resolution audio content.

[0005] In particular, music lovers or professionals in the sector are constantly on the lookout for high quality audio systems - the so-called High Fidelity or Hi-Fi systems.

[0006] Several systems and devices are currently known which are able to reproduce high quality audio signals. Such prior art solutions comprise, for example, acoustic speakers.

20 [0007] The term "speaker" refers to a transducer or set of transducers capable of transforming the electrical signal from an amplifier into an acoustic signal.

[0008] More specifically, these devices, typically used in the music industry, comprise one or more speakers, which are installed on a single chassis and are able to reproduce the different frequencies audible to the human ear (between 20Hz and 20kHz).

25 [0009] In particular, a distinction is made between amplified speakers (or active speakers) and pre-amplified speakers (or passive speakers).

[0010] Amplified speakers are equipped with at least one integrated amplifier, whilst pre-amplified speakers do not comprise any amplifier inside them. The latter allow the flexibility of the audio system to be increased as they allow, for example, only the speaker itself, or the connection and power cables, or the amplifier to be replaced.

30 [0011] However, one of the main drawbacks of these prior art solutions is that they are typically large in size, that is, they occupy considerably large volumes in order to handle high sound output levels.

[0012] Another drawback of these prior art solutions is that they generate distortion of the audio output signal, resonating and vibrating due to the pressure of the speakers inside them.

35 [0013] In fact, due to the high pressure inside the speaker, which increases as the sound volume increases, the walls of the speaker tend to resonate, interfering directly with the acoustic resonance of the speakers and causing, for example, knocking and distortion.

[0014] Another drawback of such prior art solutions is that they are often bulky. In fact, some types of speakers, such as, for example, "tower" speakers, are difficult to install in the various household environments.

40 [0015] In particular, as can be seen from Figures 1A-1B, each of these "tower" speakers typically has, along its respective longitudinal structure, a plurality of speakers equally spaced between them, and two openings in the lower portion of this structure. As will be described in more detail below, the number of acoustic interferences, in the prior art acoustic speakers, between the sound waves emitted by the respective speakers is less than the number of speakers themselves. This does not allow, for example, reproduction of the audio signal corresponding to a specific musical instrument, and thus to emulate its sound. Therefore, these prior art speakers do not allow a complete additive sound synthesis of the sound waves emitted by the respective speakers to be obtained.

45 [0016] Another drawback of these prior art solutions is that, having substantially asymmetrical shapes, they do not spread the sound (and the related vibrations) homogeneously in the surrounding environment.

[0017] Another drawback of these prior art solutions is that they typically involve high construction and maintenance costs.

50 [0018] The relevant prior art comprises the patent application GB 1303602 A, the patent application US 2010/177921 A, the patent application US 2012/195447 A1, the patent US 8967323 B1 and the patent application EP0521655 A1.

Aim of the invention

55 [0019] The aim of the invention is to overcome the drawbacks mentioned above by making an improved acoustic speaker to optimise the reproduction of audio signals.

[0020] Another aim of the invention is to make an acoustic speaker with a geometry which makes it possible to combine sound signals in order to obtain a wide range of sound varieties.

[0021] Another aim of the invention is to provide an acoustic speaker which can handle high levels of acoustic output.

[0022] Another aim of the invention is to provide an acoustic speaker which is stable and easily installed in sound systems arranged inside and/or outside different types of environments such as, for example, household environments, professional environments, theatres and so on.

[0023] Another aim of the invention is to provide an acoustic speaker which is highly reliable, relatively easy to make, and has competitive costs if compared with the prior art.

Object of the invention

[0024] The present invention is directed to an acoustic speaker according to claim 1. Further aspects of the invention are according to the dependent claims.

[0025] The specific object of the invention is therefore an acoustic speaker for the reproduction of audio signals, comprising a first speaker and a respective first chamber, for reproducing at least one first audio signal $y_1(t)$ in a first frequency range, a second speaker and a respective second chamber, for reproducing at least one second audio signal $y_2(t)$ in a second frequency range equal to or different from said first frequency range, and a third speaker and a respective third chamber, for reproducing at least one third audio signal $y_3(t)$ in a third frequency range equal to or different from said first frequency range and from said second frequency range, a main resonance chamber provided with a main opening, and a supporting structure of said speakers and said main resonance chamber. In particular, each of said first, second and third speaker is arranged on a respective vertex of an equilateral triangle which circumscribes said main opening, said first, second and third speaker and said main opening being arranged on a same plane XY and oriented according to a same direction along a Z axis, perpendicular to said plane XY, so as to reproduce a further audio signal $y(t)$ resulting from the combination of said at least one first audio signal $y_1(t)$, said at least one second audio signal $y_2(t)$ and said at least one third audio signal $y_3(t)$, and in that said further audio signal $y(t)$ results from the following formula

$$y(t) = A_o + \sum_{n=1}^{\infty} A_n \sin(n\omega t + \varphi_n)$$

, wherein said supporting structure is a resonance plate coplanar to said equilateral triangle, said resonance plate having a main opening coinciding with said main opening of said main resonance chamber, a first secondary opening for the insertion of said first speaker, a second secondary opening for the insertion of said second speaker and a third secondary opening for the insertion of said third speaker, wherein said acoustic speaker comprises a resonance structure coupled to said resonance plate, on the opposite side to the direction along which said first, second and third speakers and said main opening are oriented, said resonance structure having a regular pyramid shape with an equilateral triangular base and wherein the angle at the vertex of each side face right-angled; said resonance structure defining, together with said resonance plate, said first, second and third resonance chambers, wherein said resonance structure defines, together with said resonance plate, said first resonance chamber, said second resonance chamber, and said third resonance chamber, wherein each of said first (110), second and third resonance chambers has a regular pyramid shape with a triangular base, wherein said triangular base coincides with an equilateral triangle circumscribing said respective first, second and third secondary openings and wherein the height on an axis perpendicular to said triangular base and parallel to said Z axis, said resonance structure further defining, together with said resonance plate, said main resonance chamber having a substantially prism shape with a hexagonal base.

[0026] Conveniently, according to the invention, said acoustic speaker can be provided with a fourth speaker for reproducing at least one fourth audio signal $y_4(t)$ in a fourth frequency range equal to or different from said first frequency range, said second frequency range and said third frequency range, said fourth speaker can be inserted in said main opening and oriented along the Z axis.

[0027] Again according to the invention, said equilateral triangle which circumscribes said main opening may comprise a first side, a second side and a third side, and wherein said acoustic speaker also has a fourth secondary opening arranged in proximity to the middle of said third side, a fifth secondary opening arranged in proximity to the middle of said second side, and a sixth secondary opening arranged in proximity to the middle of said first side, wherein each of said fourth, fifth and sixth secondary openings is positioned at a respective vertex of a further equilateral triangle circumscribing said main opening, and wherein each of said fourth, fifth and sixth secondary openings has a substantially circular shape and is in fluid communication with said main resonance chamber.

[0028] Further, according to the invention, said resonance structure can comprise a first face, a second face and a third face, wherein said first face has an opening for the insertion of a first supporting element fixable to a first wall, said second face has an opening for the insertion of a second supporting element fixable to a second wall, and said third face has an opening for the insertion of a third supporting element fixable to a third wall.

[0029] Again according to the invention, said resonance plate can be made using spruce wood laths.

[0030] Conveniently, according to the invention, said resonance structure can have an internal surface made of *posidonia oceanica*.

[0031] Further according to the invention, said internal surface of said resonance structure can be designed to absorb sound waves and vibrations generated by each of said first, second, third and fourth speaker, when in use, acoustically insulating said acoustic speaker from the external environment.

5 **Brief description of drawings**

[0032] The invention is now described, by way of example and without limiting the scope of the invention, with reference to the accompanying drawings which illustrate preferred embodiments of it, in which:

10 Figure 1A shows a tower acoustic speaker, according to the prior art;
 Figure 1B shows, in a schematic view, a graphic representation of acoustic interference between sound waves generated by the speakers, according to the prior art speaker of Figure 1A;
 Figure 2 shows a front view of an improved acoustic speaker, according to an embodiment of the invention;
 Figure 3A shows a schematic view of the acoustic speaker of Figure 2;
 15 Figure 3B shows, in a schematic view, a graphic representation of acoustic interference between sound waves generated by three speakers, according to the acoustic speaker of Figure 2;
 Figure 3C shows, in a schematic view, a further graphic representation of acoustic interference between sound waves generated by four speakers, according to the acoustic speaker of Figure 2;
 Figure 4A shows, in a schematic view, a graphic representation of acoustic interference between sound waves
 20 generated by three speakers in three frequency ranges different from each other, according to Figure 3B;
 Figure 4B shows, in a schematic view, a graphic representation of acoustic interference between sound waves generated by four speakers in four frequency ranges different from each other, according to Figure 3C;
 Figure 4C shows, in a schematic view, a graphic representation of acoustic interference between sound waves generated by four speakers in three frequency ranges different from each other, according to Figure 3A;
 25 Figure 4D shows, in a schematic view, a graphic representation of acoustic interference between sound waves generated by six speakers in three frequency ranges different from each other, according to Figure 3A;
 Figure 4E shows, in a schematic view, a graphic representation of acoustic interference between sound waves generated by seven speakers in three frequency ranges different from each other, according to Figure 3A;
 Figure 4F shows, in a schematic view, a graphic representation of acoustic interference between sound waves
 30 generated by six speakers in four frequency ranges different from each other, according to Figure 3A;
 Figure 5 shows a further front view of the acoustic speaker of Figure 2;
 Figure 6 shows a perspective view of the acoustic speaker of Figure 2;
 Figure 7 shows a side view of the acoustic speaker of Figure 2 comprising a resonance plate and a resonance structure coupled together;
 35 Figure 8 shows a front view of the resonance structure of the acoustic speaker of Figure 7;
 Figure 9 shows, in detail, a coupling between the resonance plate portion and the resonance structure of the speaker of Figures 7 and 8; and
 Figure 10 shows two acoustic speakers according to a further embodiment of the invention connected to an audio system.

40

[0033] The similar parts will be indicated in the various drawings with the same numerical references.

Detailed description

45 **[0034]** With reference to Figures 2 to 10, the acoustic speaker for the reproduction of audio signals, denoted in its entirety by reference numeral 1, substantially comprises a resonance plate P1, a first speaker 100A, a second speaker 101A, a third speaker 102A, and a fourth speaker 103A, said speakers 100A, 101A, 102A and 103A being installable in said resonance plate P1, and a resonance structure P2 which can be coupled, in use, to said resonance plate P1.

50 **[0035]** With particular reference to Figures 2, 5 and 6, the resonance plate P1 of the speaker 1 according to the invention has the shape substantially of an equilateral triangular and has a first L1, a second L2 and a third L3 side. By way of example, each of said first L1, second L2 and third L3 side has a length of 50cm. However, according to their embodiments, said resonance plate P1 can have different shapes, such as, for example, a circular or square shape.

[0036] Said resonance plate P1 has a main opening 103, positioned at the centre of said resonance plate P1, as well as a first secondary opening 100 for the insertion of said first speaker 100A, a second secondary opening 101 for the
 55 insertion of said second speaker 101A, and a third secondary opening 102 for the insertion of said third speaker 102A, each of said first secondary opening 100, second secondary opening 101 and third secondary opening 102 being positioned on a respective vertex of an equilateral triangle on an XY plane circumscribing said main opening 103.

[0037] Further, said fourth speaker 103A is inserted in said main opening 103.

[0038] For this reason, said resonance plate P1 has, therefore, both a structural function, being able to support said speakers 100A, 101A, 102A and 103A, and an acoustic resonance function, amplifying the sound waves coming from the same speakers 100A, 101A, 102A and 103A.

[0039] In particular, according to the embodiment described, each of said openings 100, 101, 102, 103 has a substantially circular shape. By way of example, each of said secondary openings 100, 101, 102 has a diameter of 11cm (possibly extendable up to 13cm), whilst said main opening 103 has a diameter of 18cm. However, according to other embodiments, the shape of each of said openings 100, 101, 102, 103 may have a different shape from the above-mentioned circular shape.

[0040] In particular, as already mentioned, each of said openings 100, 101, 102, is arranged on a respective vertex of an equilateral triangle on the XY plane circumscribing said main opening 103. This arrangement of said openings 100, 101, 102, and 103, and therefore, of said speakers 100A, 101A, 102A, and 103A allows, as will be described in detail below, suitable combination of the audio signals emitted by the respective speakers 100A, 101A, 102A, and 103A.

[0041] Advantageously, said resonance plate P1 further has a fourth secondary opening 104, a fifth secondary opening 105 and a sixth secondary opening 106.

[0042] Each of said fourth 104, fifth 105 and sixth 106 secondary openings also has a substantially circular shape and is arranged at a respective vertex of a further equilateral triangle on the same plane XY circumscribing said main opening 103. By way of example, each of said openings 104, 105 and 106 has a diameter of 5cm, however this size typically depends on the size of the speaker 1.

[0043] More specifically, said fourth secondary opening 104 is arranged in proximity to the middle of said third side L3, said fifth secondary opening 105 is arranged in proximity to the middle of said second side L2, and said sixth secondary opening 106 is arranged in proximity to the middle of said first side L1.

[0044] In particular, as will be described in detail below, each of said fourth 104, fifth 105, and sixth 106 secondary openings the sound waves reproduced by said fourth 103A speaker to be conveyed to the outside environment. In fact, through the presence of these secondary openings 104, 105 and 106, the sound waves emitted along the direction of a Z axis, perpendicular to the XY plane, in the negative Z direction (that is, behind said resonance plate P1) from said fourth speaker 103A, are emitted again along the direction of the Z axis, in the positive Z direction, (that is, in front of said resonance plate P1), thus amplifying the sound reproduced by said fourth speaker 103A. In short, the rear sound waves emitted by said fourth 103A speaker are re-timed with the front sound waves emitted by the same fourth 103A speaker (this technique is called "bass reflex" in technical jargon).

[0045] According to the embodiment described, said resonance plate P1 is made of spruce wood strips.

[0046] In fact, this material has excellent properties for amplification of the sound waves generated by an instrument or device. However, said resonance plate P1 can be made from other materials such as maple or plane tree wood. By way of example, said resonance plate P1 has a height of 40 cm and a thickness of 30mm.

[0047] As mentioned, the acoustic speaker 1 according to the invention has a plurality of speakers 100A, 101A, 102A, and 103A coupled to respective resonance chambers and able to emit respective audio signals in predetermined frequency ranges within the range of frequencies audible by the human ear between 20Hz-20kHz.

[0048] In particular, said first speaker 100A is configured to reproduce at least one first audio signal $y_1(t)$ in a first frequency range, said second speaker 101A is configured to reproduce at least one second audio signal $y_2(t)$ in a second frequency range equal to or different from said first frequency range, said third speaker 102A is configured to reproduce at least one third audio signal $y_3(t)$ in a third frequency range equal to or different from said first frequency range and from said second frequency range, and said fourth speaker 103A is configured to reproduce at least one fourth audio signal $y_4(t)$ in a fourth frequency range equal or different from said first frequency range, from said second frequency range and from said third frequency range.

[0049] According to the embodiment described, said first range of frequencies is equal to 2kHz-20kHz, said second range of frequencies is equal to 500Hz-5kHz, said third range of frequencies is equal to 50Hz-2kHz, and said fourth range of frequencies is equal to 150Hz-9kHz.

[0050] For this reason, said first speaker 100A allows the reproduction of audio signals at high frequencies (this speaker is called "Tweeter" in jargon), said second speaker 101A allows the reproduction of audio signals at low frequencies (this speaker is called "Woofers" in jargon), said third speaker 102A is able to reproduce audio signals at medium frequencies (this speaker is called "Midrange" in jargon), and, finally, said fourth speaker 103A allows the reproduction of audio signals at very low frequencies (this speaker is called "Subwoofer" in jargon).

[0051] However, according to further embodiments of the invention, said acoustic speaker 1 may comprise, for example, a high-frequency amplifier and two medium-frequency stereo amplifiers without any low-frequency amplifier, or a high-frequency amplifier, two medium-frequency stereo amplifiers, and a low-frequency amplifier.

[0052] In particular, as mentioned, Figures 3B and 3C show the acoustic interference between the sound waves emitted by three and four speakers respectively, according to the layout of the acoustic speaker 1 shown in Figure 3A.

[0053] In fact, Figure 3B illustrates an embodiment of the invention wherein said acoustic speaker 1 comprises a high frequency speaker 100A inserted in said opening 100, a low frequency speaker 101A inserted in said opening 101, and

a medium frequency speaker 102A inserted in said opening 102.

[0054] This configuration, as shown in Figure 3B, allows four acoustic interferences to be obtained:

- a first acoustic interference I1 between the sound waves emitted in the high frequency range by said speaker 100A, and the sound waves emitted in the medium frequency range by said speaker 102A,
- a second acoustic interference I2 between the sound waves emitted in the medium frequency range by said speaker 102A and the sound waves emitted in the low frequency range by said speaker 101A,
- a third acoustic interference I3 between the sound waves emitted in the high frequency range by said speaker 100A and the sound waves emitted in the low frequency range by said speaker 101A, and
- a fourth acoustic interference I4, at the main opening 103, between the sound waves emitted in the high frequency range by said speaker 100A, the sound waves emitted in the medium frequency range by said speaker 102A, and the sound waves emitted in the low frequency range by said speaker 101A.

[0055] Figure 3C, on the other hand, illustrates an embodiment of the invention wherein said acoustic speaker 1 comprises a high frequency speaker 100A inserted in said opening 100, a low frequency speaker 101A inserted in said opening 101, a medium frequency speaker 102A inserted in said opening 102, and a very low frequency speaker 103A inserted in said main opening 103.

[0056] In this case, due to the insertion of the speaker 103A in said main opening 103, the number of acoustic interferences between the sound waves emitted by the respective speakers is greater than the number of acoustic interferences of the case described above and illustrated in Figure 3B.

[0057] In fact, this configuration, as shown in figure 3C, allows seven acoustic interferences to be obtained:

- a further first acoustic interference I1+IS1 between the sound waves emitted in the high frequency range by said speaker 100A, the sound waves emitted in the medium frequency range by said speaker 102A, and the sound waves emitted in the very low frequency range by said speaker 103A,
- a further second acoustic interference I2+IS2 between the sound waves emitted in the medium frequency range by said speaker 102A, the sound waves emitted in the low frequency range by said speaker 101A, and the sound waves emitted in the very low frequency range by said speaker 103A,
- a further third I3+IS3 acoustic interference between the sound waves emitted in the high frequency range by said speaker 100A, the sound waves emitted in the low frequency range by said speaker 101A, and the sound waves emitted in the very low frequency range by said speaker 103A,
- a further fourth acoustic interference I4+IS4, at the main opening 103, between the sound waves emitted in the high frequency range by said speaker 100A, the sound waves emitted in the medium frequency range by said speaker 102A, the sound waves emitted in the low frequency range by said speaker 101A, and the sound waves emitted in the very low frequency range by said speaker 103A,
- a fifth IS1 acoustic interference between the sound waves emitted in the high frequency range by said speaker 100A and the sound waves emitted in the very low frequency range by said speaker 103A,
- a sixth IS2 acoustic interference between the sound waves emitted in the medium frequency range by said speaker 102A and the sound waves emitted in the very low frequency range by said speaker 103A, and
- a seventh IS3 acoustic interference between the sound waves emitted in the low frequency range by said speaker 101A and the sound waves emitted in the very low frequency range by said speaker 103A.

[0058] Figures 4C to 4F, as mentioned, show in schematic view a graphic representation of acoustic interference between sound waves generated respectively by four speakers in three frequency ranges different from each other, by six speakers in three frequency ranges different from each other, by seven speakers in three frequency ranges different from each other and by six speakers in four frequency ranges different from each other.

[0059] As shown in particular in Figure 6, said first 100A, second 101A and third 102A speakers are arranged on the same XY plane and are oriented in the same direction along the Z axis perpendicular to said XY plane, so as to reproduce, in the positive Z direction, a further audio signal $y(t)$ resulting from the combination of said first audio signal $y_1(t)$, said second audio signal $y_2(t)$ and said third audio signal $y_3(t)$.

[0060] As is known, the Fast Fourier Transform (FFT) is an optimised algorithm for calculating the Discrete Fourier Transform (DFT) or its inverse, and is typically used within dedicated software applications for personal computers, for example, in digital signal processing.

[0061] In particular, in harmonic analysis, from a mathematical point of view, and in sound theory, the function of the Fourier Series is given by:

$$f(t) = A_0 + A_1 \sin(\omega t + \varphi_1) + A_2 \sin(2\omega t + \varphi_2) + A_3 \sin(3\omega t + \varphi_3) + \dots$$

where the first term of pulse ω of amplitude A_1 and phase φ_1 is called First Harmonic or Fundamental Harmonic, the second term of amplitude A_2 and phase φ_2 represents the second harmonic, and the third term of amplitude A_3 and phase φ_3 represents the Third Harmonic.

[0062] Therefore, by extending the series to n terms, there is an overlapping of several sinusoidal signals of opportune amplitudes and frequencies out of phase with each other:

$$f(t) = A_0 + \sum_{n=1}^{\infty} A_n \sin(n\omega t + \varphi_n)$$

where the term of pulse amplitude A_n and phase φ_n represents the n -th Harmonic.

[0063] For this reason, acoustic speaker 1 is able to reproduce the waveform corresponding to the timbre of a specific instrument, such as a violin or guitar, emulating its sound.

[0064] In fact, as mentioned, according to Fourier's theory, the waveform of a signal and its envelope over time can be obtained by combining multiple frequency sinusoidal waves of a fundamental frequency (the so-called "harmonics"). This can also be applied to the waveforms generated by a musical instrument, allowing, for example, the timbre and sound to be broken down into individual sine waves and vice versa.

[0065] As mentioned above, the acoustic speaker 1 comprises a P2 resonance structure which can be coupled, in use, to said resonance plate P1.

[0066] With particular reference to Figures 7 and 8, said resonance structure P2 has a substantially regular pyramid shape with an equilateral triangular base (or equilateral tetrahedral base), wherein the angle at the vertex of each side face is right-angled.

[0067] In particular, said resonance structure P2 defines, together with said resonance plate (P1), a main resonance chamber 113, associated with said main opening 103 and, when present, with said fourth speaker 103A; as well as a first secondary resonance chamber 110, a second secondary resonance chamber 111, and a third secondary resonance chamber 112, associated respectively to said first secondary opening 100 and to said first speaker 100A, to said second secondary opening 101 and to said second speaker 101A and to said third secondary opening 102 and to said third speaker 102A.

[0068] Said main resonance chamber 113 has a substantially prism shape with a hexagonal base, wherein said hexagonal base circumscribes said main opening 103. Moreover, each of said first 110, second 111 and third 112 secondary resonance chambers has a substantially pyramid shape with a triangular base, wherein said triangular base coincides with each triangle circumscribing said respective first 100, second 101 and third 102 secondary opening and the height is positioned on an axis perpendicular to said triangular base and parallel to the Z axis.

[0069] In particular, said main resonance chamber 113, in the presence of said fourth speaker, becomes active, amplifying the further audio signal $y(t)$ (or Additive Synthesis signal) through continuous pressure flows out of phase between the main opening 103, in the positive Z direction, and said fourth secondary opening 104, said fifth secondary opening 105 and said sixth secondary opening 106.

[0070] As shown in Figure 8, the resonance structure P2 comprises a first face 11, a second face 12 and a third face 13.

[0071] More in detail, said first face 11 has a further fourth opening 114 for the insertion of a first supporting element fixable to a first wall, said second face 12 has a further fifth opening 115 for the insertion of a second supporting element fixable to a second wall, and said third face 13 has a further sixth opening 116 for the insertion of a third supporting element fixable to a third wall.

[0072] In fact, each supporting element is able to constrain the respective face by which it is fixed to a wall by means of connecting means such as screws and the like.

[0073] Advantageously, said acoustic speaker 1 can be positioned between two adjacent walls and the ceiling in such a way that, for example, said first face 11 is fixed to a first wall, said second face 12 is fixed to a second wall and said third face 13 is fixed to said ceiling.

[0074] This guarantees a high stability and a homogeneous diffusion of sound waves inside the room and between the walls wherein said acoustic speaker 1 is positioned.

[0075] Moreover, according to a further embodiment of the invention, said resonance structure P2' has an internal surface P2' made by means of posidonia oceanica to acoustically isolate said speaker 1.

[0076] In particular, said internal surface P2' of said resonance structure P2 is able to absorb sound waves and vibrations generated along the direction of the Z axis, in the negative Z direction, by each of said first 100A, second 101A, third 102A and fourth 103A speakers, when in use, acoustically isolating said acoustic speaker 1 from the external

environment.

[0077] Moreover, this main resonance chamber 113, in the absence of the fourth speaker 103A, is not coated with resin and posidonia oceanica like, for example, the inner surface of a guitar.

[0078] Figure 9, as mentioned, shows, according to the embodiment described, the coupling between the resonance plate P1 and the resonance structure P2 of the acoustic speaker 1.

[0079] Finally, as shown in Figure 10, the acoustic speaker 1, can be connected to an audio system S comprising electrical signal generation devices and/or display devices and/or desktop PC.

[0080] In particular, said acoustic speaker 1 is positioned on any of said first face 11, second face 12 and said third face 13, being inclined by 45° degrees in the direction of the positive Z axes, in such a way as to emulate the reflection phenomenon typical of classical theatres.

[0081] Said S system can be, for example, a Hi-Fi system ("High Fidelity") equipped, among other things, with integrated amplifiers, computers, and/or A/D converters, and possibly connected to a TV or projector.

[0082] Further, said audio system S can comprise additional resonance chambers, equipped with a low frequency amplifier, on which said acoustic speaker 1 can be positioned. By way of example, this configuration allows a total output of between 1400W and 2000W to be reached.

Advantages

[0083] A first advantage of the acoustic speaker according to the invention is to optimise the reproduction of audio signals.

[0084] A further advantage of the acoustic speaker according to the invention is that it handles high sound output levels whilst occupying little space.

[0085] A further advantage of the acoustic speaker according to the invention is that it can be easily installed and configured in audio systems located inside and/or outside of different rooms or easily placed on any side and/or top of walls.

[0086] A further advantage of the acoustic speaker according to the invention is that it comprises a plurality of speakers isolated acoustically from each other.

[0087] A further advantage of the acoustic speaker according to the invention is that it has a symmetrical and configurable structure. Moreover, the arrangement of the speakers, as described above, allows the audio signals associated with each speaker to be combined with a respective frequency.

[0088] A further advantage of the speaker according to the invention is that it has an equilateral rectangular pyramidal shape which guarantees greater stability and fewer vibrations compared to the prior art systems.

[0089] A further advantage of the speaker according to the invention is that it is a four-sided element and therefore, for the same volume, it has a smaller total surface area than the prior art 6-sided systems. This allows a considerable saving of time and materials during construction.

Claims

1. An acoustic speaker (1) for the reproduction of audio signals, comprising

a first speaker (100A) and a respective first chamber, for reproducing at least one first audio signal $y_1(t)$ in a first frequency range, a second speaker (101A) and a respective second chamber, for reproducing at least one second audio signal $y_2(t)$ in a second frequency range equal to or different from said first frequency range, and a third speaker (102A) and a respective third chamber, for reproducing at least one third audio signal $y_3(t)$ in a third frequency range equal to or different from said first frequency range and from said second frequency range, a main resonance chamber (113) provided with a main opening (103), and a supporting structure of said speakers and said main resonance chamber (113), wherein each of said first (100A), second (101A) and third (102A) speaker is arranged on a respective vertex of an equilateral triangle which circumscribes said main opening (103), said first (100A), second (101A) and third (102A) speaker and said main opening (103) being arranged on a same plane XY and oriented according to a same direction along a Z axis, perpendicular to said plane XY, so as to reproduce a further audio signal $y(t)$ resulting from the combination of said at least one first audio signal $y_1(t)$, said at least one second audio signal $y_2(t)$ and said at least one third audio signal $y_3(t)$, wherein said supporting structure is a resonance plate (P1) coplanar to said equilateral triangle, said resonance plate (P1) having a main opening coinciding with said main opening (103) of said main resonance chamber (113), a first secondary opening (100) for the insertion of said first speaker (100A), a second secondary opening (101) for the insertion of said second speaker (101A) and a third secondary opening (102) for the insertion of said third speaker (102A),

wherein said acoustic speaker (1) comprises a resonance structure (P2) coupled to said resonance plate (P1), on the opposite side to the direction along which are oriented said first (100A), second (101A) and third (102A) speaker and said main opening (103), said resonance structure (P2) having a regular pyramid shape with equilateral triangular base and wherein the angle at the vertex of each side face is right-angled; said resonance structure (P2) defining, together with said resonance plate (P1), said first (110), second (111) and third (112) resonance chamber,

said acoustic speaker (1) being **characterised in that** said resonance structure (P2) defines, together with said resonance plate (P1), said first resonance chamber (110), said second resonance chamber (111), and said third resonance chamber (112), wherein each of said first (110), second (111) and third (112) resonance chamber has a regular pyramid shape with a triangular base, wherein said triangular base coincides with an equilateral triangle circumscribing said respective first (100), second (101) and third (102) secondary opening and wherein the height on a perpendicular axis to said triangular base is parallel to said Z axis
said resonance structure (P2) further defining, together with said resonance plate (P1), said main resonance chamber (113) having a substantially prism shape with a hexagonal base.

2. The acoustic speaker (1) according to the previous claim, **characterised**

in that said acoustic speaker (1) is provided with a fourth speaker (103A) for reproducing at least one fourth audio signal $y_4(t)$ in a fourth frequency range equal to or different from said first frequency range, said second frequency range and said third frequency range,

in that said fourth speaker (103A) is inserted into said main opening (103) and oriented along the Z axis.

3. The acoustic speaker (1) according to any one of the preceding claims, **characterised in that** said equilateral triangle which circumscribes said main opening (103) comprises a first side (L1), a second side (L2) and a third side (L3),

and wherein said acoustic speaker (1) further has a fourth secondary opening (104) arranged in proximity to the middle of said third side (L3), a fifth secondary opening (105) arranged in proximity to the middle of said second side (L2), and a sixth secondary opening (106) arranged in proximity to the middle of said first side (L1), wherein each of said fourth (104), fifth (105), and sixth (106) secondary opening is arranged at a respective vertex of a further equilateral triangle which circumscribes said main opening (103), and wherein each of said fourth (104), fifth (105), and sixth (106) secondary opening has a substantially circular shape and is in fluid communication with said main resonance chamber (113).

4. The acoustic speaker (1) according to any one of claims 1 or 3, **characterised in that** said resonance structure (P2) comprises a first face (11), a second face (12) and a third face (13), wherein

said first face (11) has an opening (114) for inserting a first supporting element fixable to a first wall,
said second face (12) has an opening (115) for inserting a second supporting element fixable to a second wall,
said third face (13) has an opening (116) for inserting a third supporting element fixable to a third wall.

5. The acoustic speaker (1) according to any one of the preceding claims, **characterised in that** said resonance plate (P1) is made of spruce wood laths.

6. The acoustic speaker (1) according to any one of claims 1 or 3 to 5, **characterised in that** said resonance structure (P2) has an internal surface (P2') made of posidonia oceanica.

7. The acoustic speaker (1) according to claim 2, **characterised in that** said internal surface (P2') of said resonance structure (P2) is designed to absorb sound waves and vibrations generated by each of said first (100A), second (101A), third (102A) and fourth (103A) speaker, when in use, acoustically insulating said acoustic speaker (1) from the external environment.

Patentansprüche

1. Akustischer Lautsprecher (1) zur Wiedergabe von Audiosignalen, umfassend

einen ersten Lautsprecher (100A) und eine entsprechende erste Kammer zum Wiedergeben von mindestens einem ersten Audiosignal $y_1(t)$ in einem ersten Frequenzbereich, einen zweiten Lautsprecher (101A) und eine entsprechende zweite Kammer zum Wiedergeben von mindestens einem zweiten Audiosignal $y_2(t)$ in einem zweiten Frequenzbereich, der gleich wie der erste Frequenzbereich ist oder sich davon unterscheidet, und

5 einen dritten Lautsprecher (102A) und eine entsprechende dritte Kammer zum Wiedergeben von mindestens einem dritten Audiosignal $y_3(t)$ in einem dritten Frequenzbereich, der gleich wie der erste Frequenzbereich und der zweite Frequenzbereich ist oder sich davon unterscheidet,

einen Hauptresonanzkammer (113), die mit einer Hauptöffnung (103) versehen ist, und

eine Trägerstruktur der Lautsprecher und der Hauptresonanzkammer (113),

10 wobei jeder von dem ersten (100A), zweiten (101A) und dritten (102A) Lautsprecher auf einer jeweiligen Spitze eines gleichseitigen Dreiecks angeordnet ist, das die Hauptöffnung (103) umschreibt, wobei der erste (100A), zweite (101A) und dritte (102A) Lautsprecher und die Hauptöffnung (103) auf einer gleichen Ebene XY angeordnet und gemäß einer gleichen Richtung entlang einer Z-Achse senkrecht zu der Ebene XY ausgerichtet sind, um ein weiteres Audiosignal $y(t)$ wiederzugeben, das aus der Kombination des mindestens einen ersten Audiosignals $y_1(t)$, des mindestens einen zweiten Audiosignals $y_2(t)$ und des mindestens einen dritten Audiosignals $y_3(t)$ resultiert,

15 wobei die Trägerstruktur eine Resonanzplatte (P1) koplanar zu dem gleichseitigen Dreieck ist, wobei die Resonanzplatte (P1) eine Hauptöffnung, die mit der Hauptöffnung (103) der Hauptresonanzkammer (113) zusammenfällt, eine erste sekundäre Öffnung (100) zum Einführen des ersten Lautsprechers (100A), eine zweite sekundäre Öffnung (101) zum Einführen des zweiten Lautsprechers (101A) und eine dritte sekundäre Öffnung (102) zum Einführen des dritten Lautsprechers (102A) aufweist,

20 wobei der akustische Lautsprecher (1) eine Resonanzstruktur (P2) umfasst, die mit der Resonanzplatte (P1) gekoppelt ist, auf der gegenüberliegenden Seite der Richtung, entlang derer der erste (100A), zweite (101A) und dritte (102A) Lautsprecher und die Hauptöffnung (103) ausgerichtet sind, wobei die Resonanzstruktur (P2) eine regelmäßige Pyramidenform mit gleichseitiger dreieckiger Basis aufweist und wobei der Winkel an dem Scheitelpunkt jeder Seitenfläche rechtwinklig ist; wobei die Resonanzstruktur (P2) zusammen mit der Resonanzplatte (P1) die erste (110), zweite (111) und dritte (112) Resonanzkammer definiert,

25 wobei der akustische Lautsprecher (1) **dadurch gekennzeichnet ist, dass** die Resonanzstruktur (P2) zusammen mit der Resonanzplatte (P1) die erste Resonanzkammer (110), die zweite Resonanzkammer (111) und die dritte Resonanzkammer (112) definiert, wobei sowohl die erste (110), zweite (111) und dritte (112) Resonanzkammer eine regelmäßige Pyramidenform mit einer dreieckigen Basis aufweist, wobei die dreieckige Basis mit einem gleichseitigen Dreieck zusammenfällt, das die jeweilige erste (100), zweite (101) und dritte (102) sekundäre Öffnung umschreibt, und wobei die Höhe auf einer senkrechten Achse zu der dreieckigen Basis parallel zu der Z-Achse ist,

30 wobei die Resonanzstruktur (P2) ferner zusammen mit der Resonanzplatte (P1) die Hauptresonanzkammer (113) definiert, die im Wesentlichen die Form eines Prismas mit einer sechseckigen Basis aufweist.

2. Akustischer Lautsprecher (1) nach dem vorherigen Anspruch, **dadurch gekennzeichnet**

40 **dass** der akustische Lautsprecher (1) mit einem vierten Lautsprecher (103A) versehen ist, um mindestens ein viertes Audiosignal $y_4(t)$ in einem vierten Frequenzbereich wiederzugeben, der gleich wie der oder verschieden von dem ersten Frequenzbereich, dem zweiten Frequenzbereich und dem dritten Frequenzbereich ist, **dass** der vierte Lautsprecher (103A) in die Hauptöffnung (103) eingesetzt und entlang der Z-Achse ausgerichtet ist.

3. Akustischer Lautsprecher (1) nach einem der vorherigen Ansprüche, **dadurch gekennzeichnet, dass** das gleichseitige Dreieck, das die Hauptöffnung (103) umschreibt, eine erste Seite (L1), eine zweite Seite (L2) und eine dritte Seite (L3) umfasst,

50 und wobei der akustische Lautsprecher (1) ferner eine vierte sekundäre Öffnung (104) aufweist, die in der Nähe der Mitte der dritten Seite (L3) angeordnet ist, eine fünfte sekundäre Öffnung (105), die in der Nähe der Mitte der zweiten Seite (L2) angeordnet ist, und eine sechste sekundäre Öffnung (106), die in der Nähe der Mitte der ersten Seite (L1) angeordnet ist,

wobei jede von der vierten (104), fünften (105) und sechsten (106) sekundären Öffnung an einem jeweiligen Scheitelpunkt eines weiteren gleichseitigen Dreiecks angeordnet ist, das die Hauptöffnung (103) umschreibt, und wobei jede von der vierten (104), fünften (105) und sechsten (106) sekundären Öffnung eine im Wesentlichen kreisförmige Form aufweist und in Fluidverbindung mit der Hauptresonanzkammer (113) ist.

55

4. Akustischer Lautsprecher (1) nach einem der Ansprüche 1 oder 3, **dadurch gekennzeichnet, dass** die Resonanzstruktur (P2) eine erste Fläche (11), eine zweite Fläche (12) und eine dritte Fläche (13) umfasst, wobei

5 die erste Fläche (11) eine Öffnung (114) zum Einführen eines ersten Tragelements aufweist, das an einer ersten Wand befestigt werden kann,
 die zweite Fläche (12) eine Öffnung (115) zum Einführen eines zweiten Tragelements aufweist, das an einer zweiten Wand befestigt werden kann,
 10 die dritte Fläche (13) eine Öffnung (116) zum Einführen eines dritten Tragelements aufweist, das an einer dritten Wand befestigt werden kann.

5. Akustischer Lautsprecher (1) nach einem der vorherigen Ansprüche, **dadurch gekennzeichnet, dass** die Resonanzplatte (P1) aus Fichtenholzleisten gefertigt ist.

6. Akustischer Lautsprecher (1) nach einem der Ansprüche 1 oder 3 bis 5, **dadurch gekennzeichnet, dass** die Resonanzstruktur (P2) eine Innenfläche (P2') aufweist, die aus Posidonia oceanica gefertigt ist.

7. Akustischer Lautsprecher (1) nach Anspruch 2, **dadurch gekennzeichnet, dass** die Innenfläche (P2') der Resonanzstruktur (P2) konstruiert ist, um Schallwellen und Schwingungen zu absorbieren, die von jedem von dem ersten (100A), zweiten (101A), dritten (102A) und vierten (103A) Lautsprecher erzeugt werden, wenn sie in Gebrauch sind, wodurch der akustische Lautsprecher (1) akustisch von der äußeren Umgebung isoliert

Revendications

1. Haut-parleur acoustique (1) pour la reproduction de signaux audio, comprenant un premier haut-parleur (100A) et une première chambre respective, pour reproduire au moins un premier signal audio $y_1(t)$ dans une première plage de fréquences, un deuxième haut-parleur (101A) et une deuxième chambre respective, pour reproduire au moins un deuxième signal audio $y_2(t)$ dans une deuxième plage de fréquences égale ou différente de ladite première plage de fréquences, et un troisième haut-parleur (102A) et une troisième chambre respective, pour reproduire au moins un troisième signal audio $y_3(t)$ dans une troisième plage de fréquences égale ou différente de ladite première plage de fréquences et de ladite deuxième plage de fréquences,

une chambre de résonance principale (113) pourvue d'une ouverture principale (103), et une structure de support desdits haut-parleurs et de ladite chambre de résonance principale (113), dans lequel chacun desdits premier (100A), deuxième (101A) et troisième (102A) haut-parleurs est agencé sur un sommet respectif d'un triangle équilatéral qui circonscrit ladite ouverture principale (103), lesdits premier (100A), deuxième (101A) et troisième (102A) haut-parleur et ladite ouverture principale (103) étant agencés sur un même plan XY et orientés selon une même direction selon un axe Z, perpendiculaire audit plan XY, de manière à reproduire un signal audio supplémentaire $y(t)$ résultant de la combinaison dudit au moins un premier signal audio $y_1(t)$, dudit au moins un deuxième signal audio $y_2(t)$ et dudit au moins un troisième signal audio $y_3(t)$, dans lequel ladite structure de support est une plaque de résonance (P1) coplanaire audit triangle équilatéral, ladite plaque de résonance (P1) présentant une ouverture principale coïncidant avec ladite ouverture principale (103) de ladite chambre de résonance principale (113), une première ouverture secondaire (100) pour l'insertion dudit premier haut-parleur (100A), une deuxième ouverture secondaire (101) pour l'insertion dudit deuxième haut-parleur (101A) et une troisième ouverture secondaire (102) pour l'insertion dudit troisième haut-parleur (102A), dans lequel ledit haut-parleur acoustique (1) comprend une structure de résonance (P2) couplée à ladite plaque de résonance (P1), du côté opposé à la direction le long de laquelle sont orientés lesdits premier (100A), deuxième (101A) et troisième (102A) haut-parleurs et ladite ouverture principale (103), ladite structure de résonance (P2) présentant une forme de pyramide régulière avec une base triangulaire équilatérale et dans lequel l'angle au sommet de chaque face latérale est à angle droit; ladite structure de résonance (P2) définissant, avec ladite plaque de résonance (P1), lesdites première (110), deuxième (111) et troisième (112) chambres de résonance,

ledit haut-parleur acoustique (1) étant **caractérisé en ce que** ladite structure de résonance (P2) définit, avec ladite plaque de résonance (P1), ladite première chambre de résonance (110), ladite deuxième chambre de résonance (111) et ladite troisième chambre de résonance (112), dans lequel chacune desdites première (110), deuxième (111) et troisième (112) chambres de résonance a une forme de pyramide régulière avec une base triangulaire, dans lequel ladite base triangulaire coïncide avec un triangle équilatéral circonscrivant lesdites première (100), deuxième (101) et troisième (102) ouvertures secondaires et dans lequel la hauteur sur un axe

perpendiculaire à ladite base triangulaire est parallèle audit axe Z
ladite structure de résonance (P2) définissant en outre, avec ladite plaque de résonance (P1), ladite chambre de résonance principale (113) ayant sensiblement une forme de prisme avec une base hexagonale.

5 2. Haut-parleur acoustique (1) selon la revendication précédente, **caractérisé**

10 **en ce que** ledit haut-parleur acoustique (1) est pourvu d'un quatrième haut-parleur (103A) pour reproduire au moins un quatrième signal audio $y_4(t)$ dans une quatrième plage de fréquences égale ou différente de ladite première plage de fréquences, ladite deuxième plage de fréquences et ladite troisième plage de fréquences, **en ce que** ledit quatrième haut-parleur (103A) est inséré dans ladite ouverture principale (103) et orienté le long de l'axe Z.

15 3. Haut-parleur acoustique (1) selon l'une quelconque des revendications précédentes, **caractérisé en ce que** ledit triangle équilatéral qui circonscrit ladite ouverture principale (103) comprend un premier côté (L1), un deuxième côté (L2) et un troisième côté (L3),

20 et dans lequel ledit haut-parleur acoustique (1) a en outre une quatrième ouverture secondaire (104) agencée à proximité du milieu dudit troisième côté (L3), une cinquième ouverture secondaire (105) agencée à proximité du milieu dudit deuxième côté (L2), et une sixième ouverture secondaire (106) agencée à proximité du milieu dudit premier côté (L1),

25 dans lequel chacune desdites quatrième (104), cinquième (105) et sixième (106) ouvertures secondaires est agencée à un sommet respectif d'un triangle équilatéral supplémentaire qui circonscrit ladite ouverture principale (103), et

30 dans lequel chacune desdites quatrième (104), cinquième (105) et sixième (106) ouvertures secondaires a une forme sensiblement circulaire et est en communication fluïdique avec ladite chambre de résonance principale (113).

35 4. Haut-parleur acoustique (1) selon l'une quelconque des revendications 1 ou 3, **caractérisé en ce que** ladite structure de résonance (P2) comprend une première face (11), une deuxième face (12) et une troisième face (13), dans lequel

40 ladite première face (11) a une ouverture (114) pour insérer un premier élément de support pouvant être fixé à une première paroi,

45 ladite deuxième face (12) a une ouverture (115) pour insérer un deuxième élément de support pouvant être fixé à une deuxième paroi,

50 ladite troisième face (13) a une ouverture (116) pour insérer un troisième élément de support pouvant être fixé à une troisième paroi.

55 5. Haut-parleur acoustique (1) selon l'une quelconque des revendications précédentes, **caractérisé en ce que** ladite plaque de résonance (P1) est constituée de lattes de bois d'épicéa.

6. Haut-parleur acoustique (1) selon l'une quelconque des revendications 1 ou 3 à 5, **caractérisé en ce que** ladite structure de résonance (P2) a une surface interne (P2') en posidonie océanique.

7. Haut-parleur acoustique (1) selon la revendication 2, **caractérisé en ce que** ladite surface interne (P2') de ladite structure de résonance (P2) est conçue pour absorber les ondes sonores et les vibrations générées par chacun desdits premier (100A), deuxième (101A), troisième (102A) et quatrième (103A) haut-parleur, lorsqu'ils sont utilisés, isolant acoustiquement ledit haut-parleur acoustique (1) de l'environnement externe.

50

55

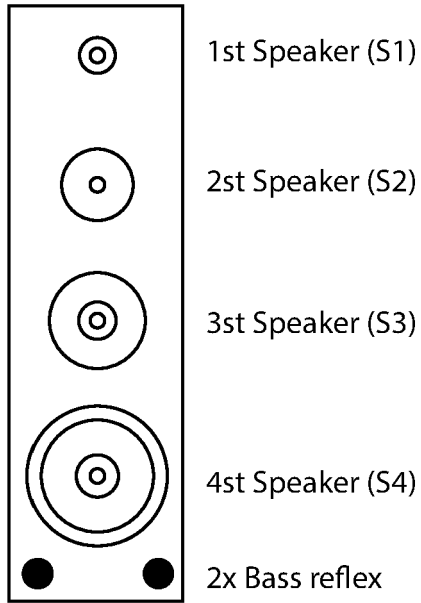

Fig.1a

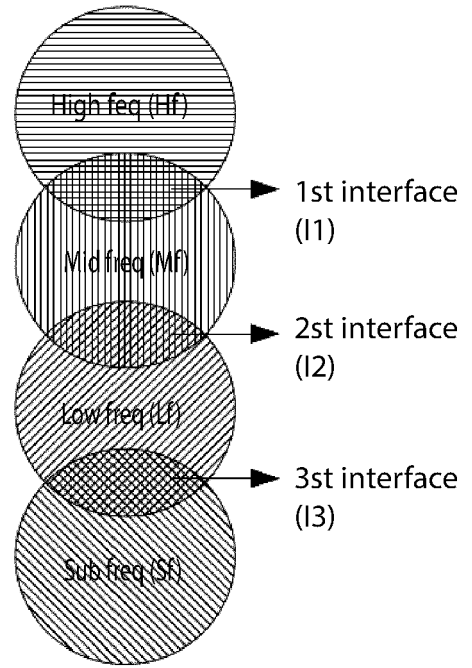

Fig.1b

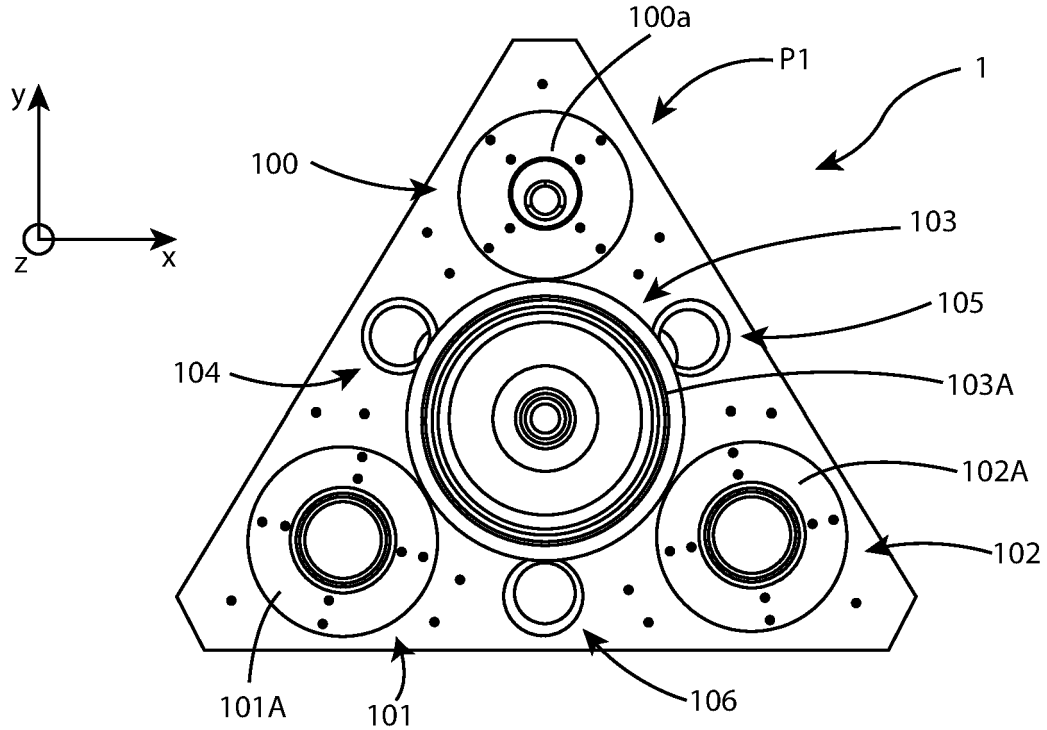

Fig.2

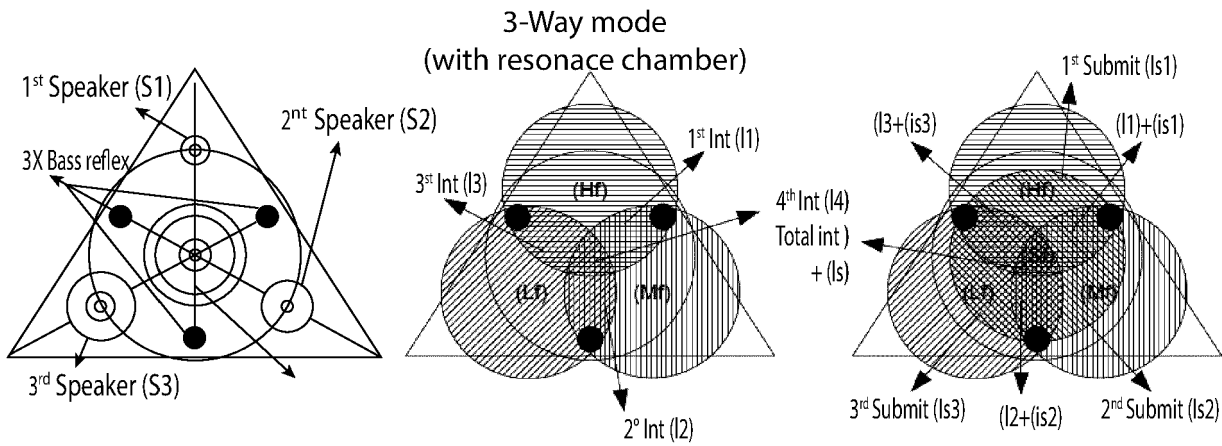

Fig.3a

Fig.3b

Fig.3c

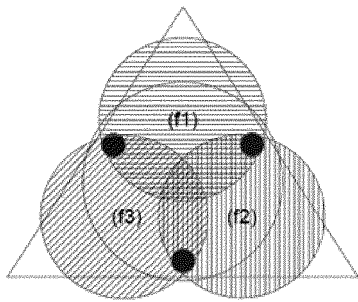

Fig.4a

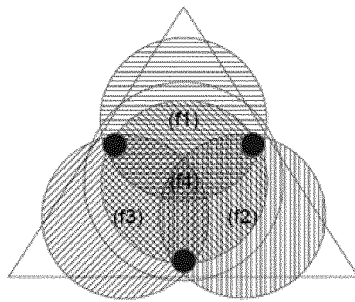

Fig.4b

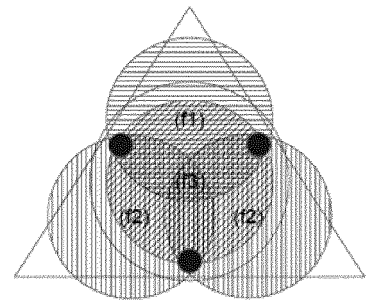

Fig.4c

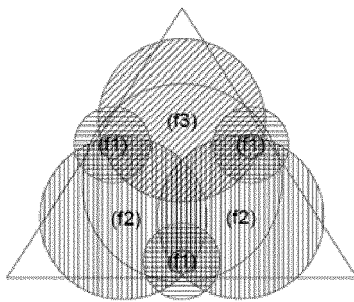

Fig.4d

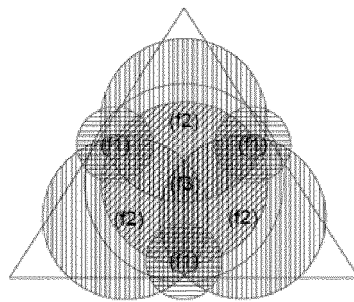

Fig.4e

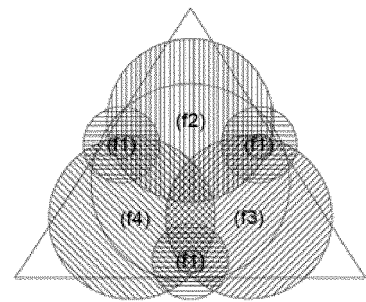

Fig.4a

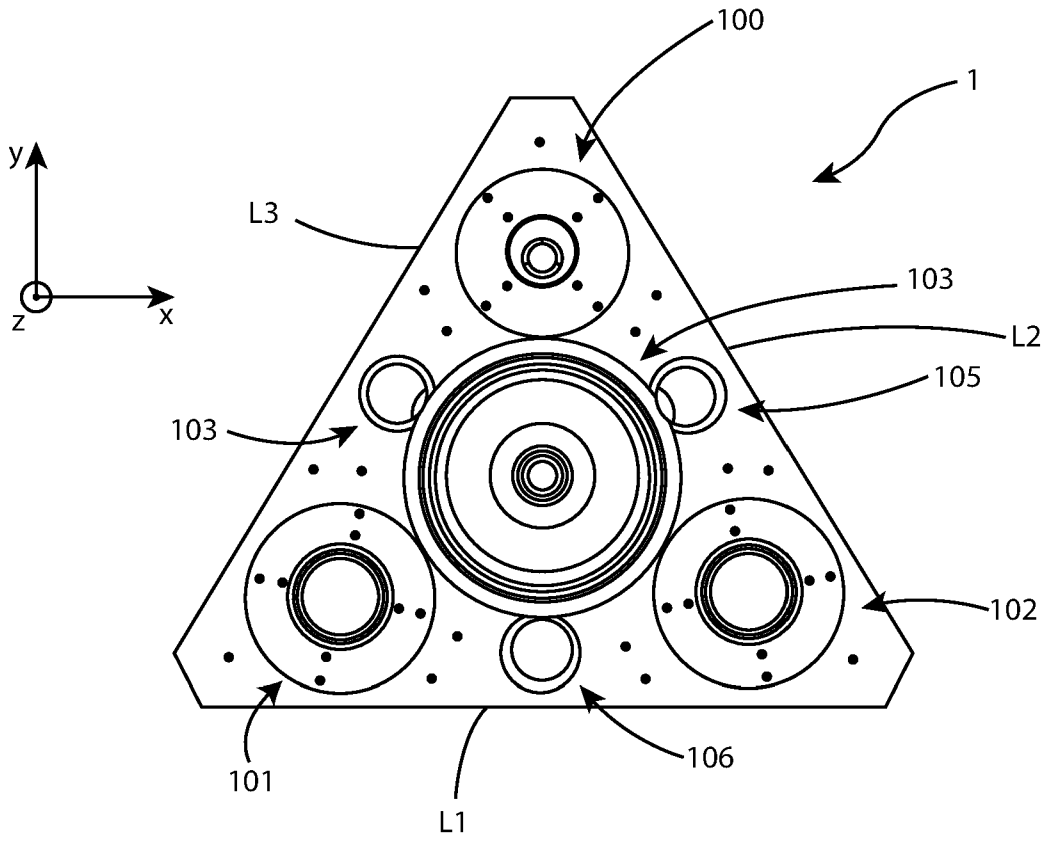

Fig.5

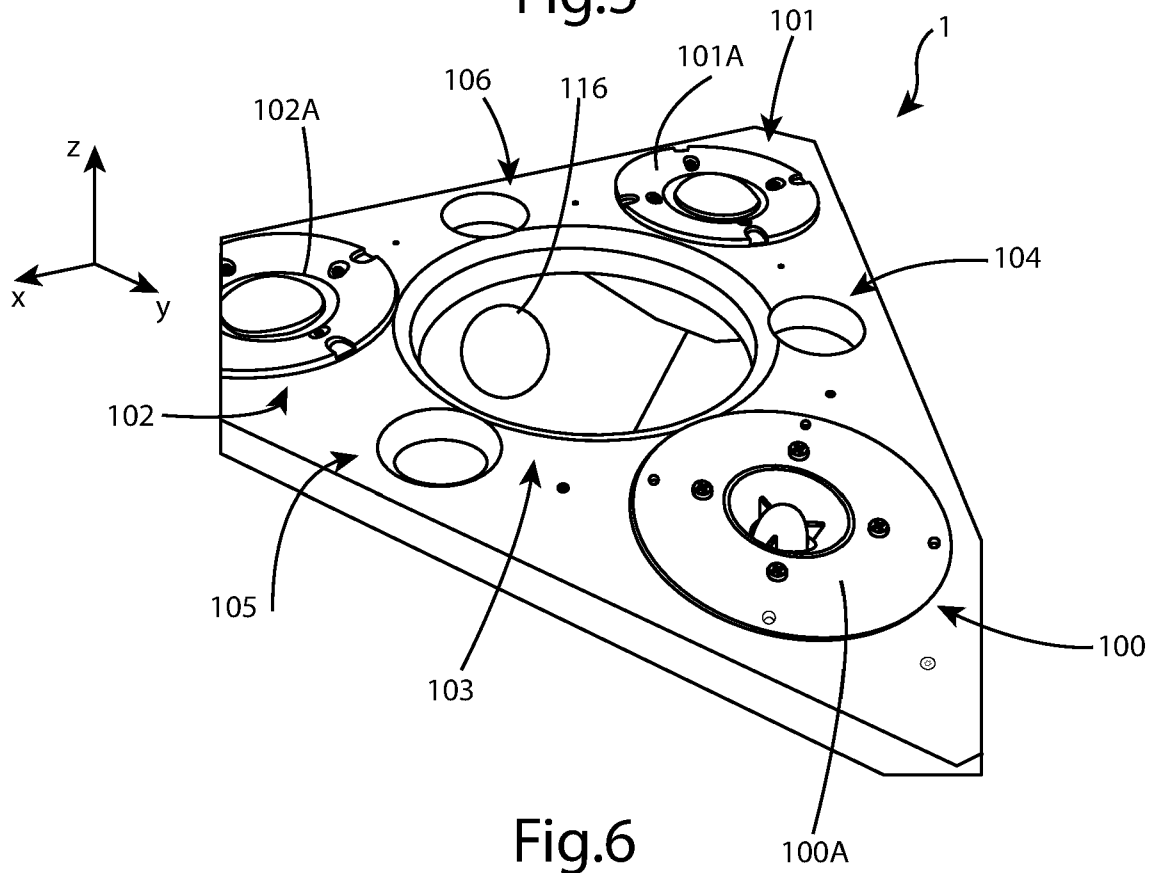

Fig.6

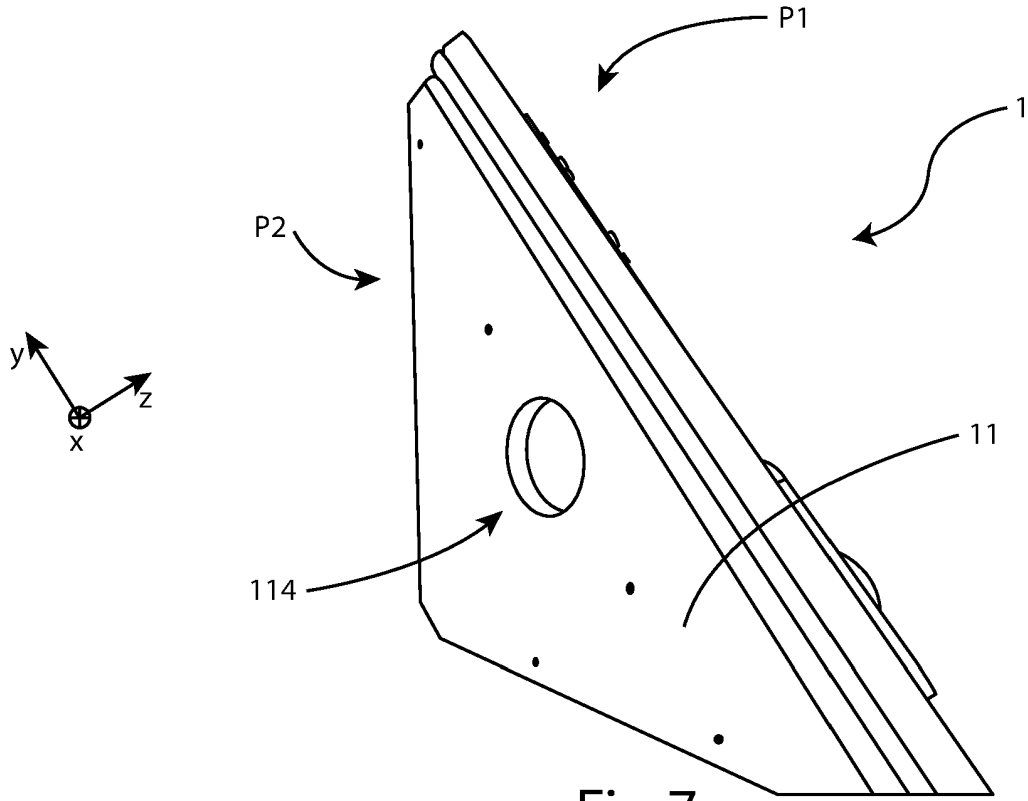

Fig.7

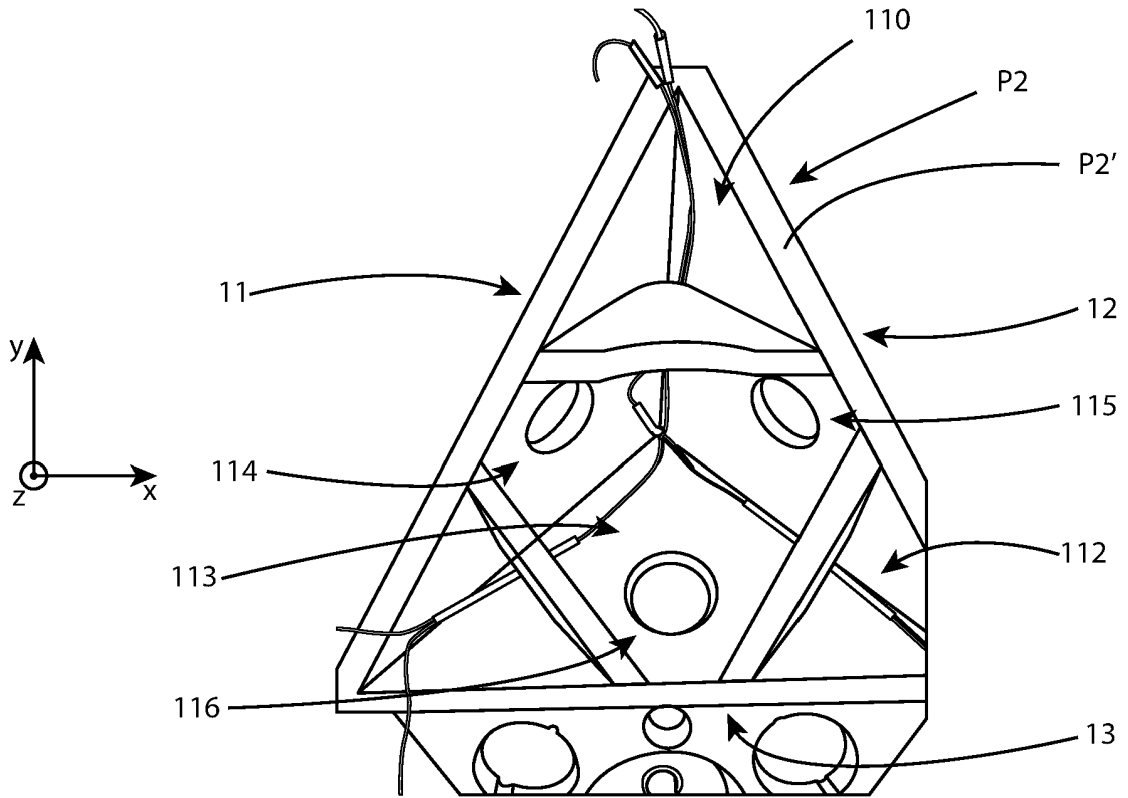

Fig.8

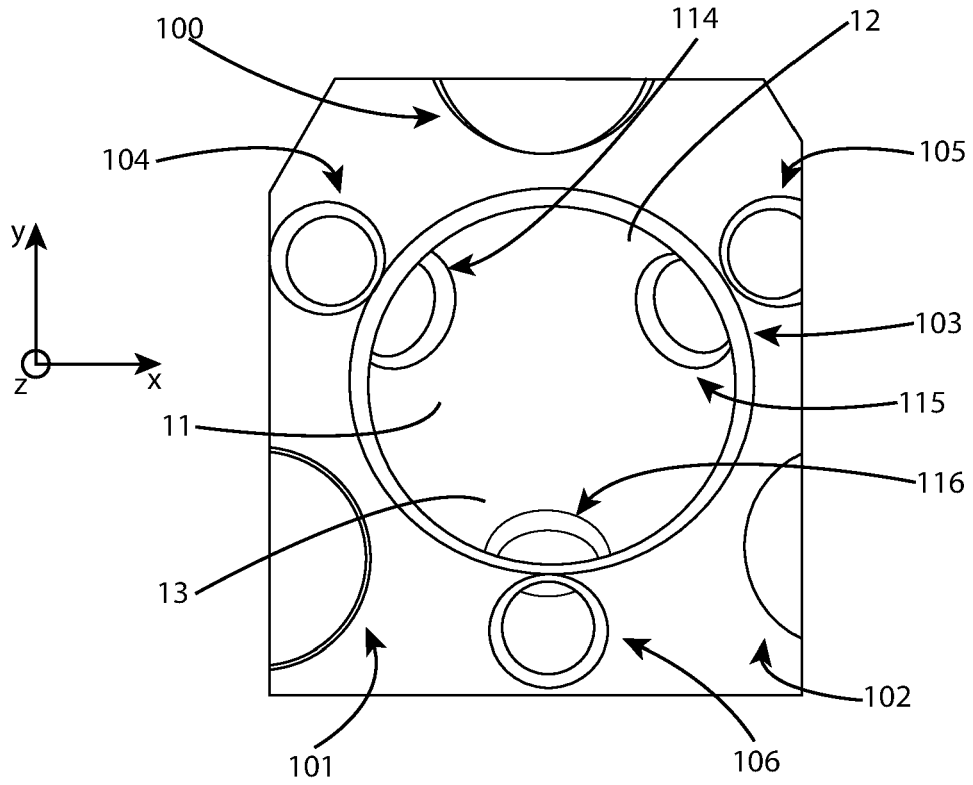

Fig.9

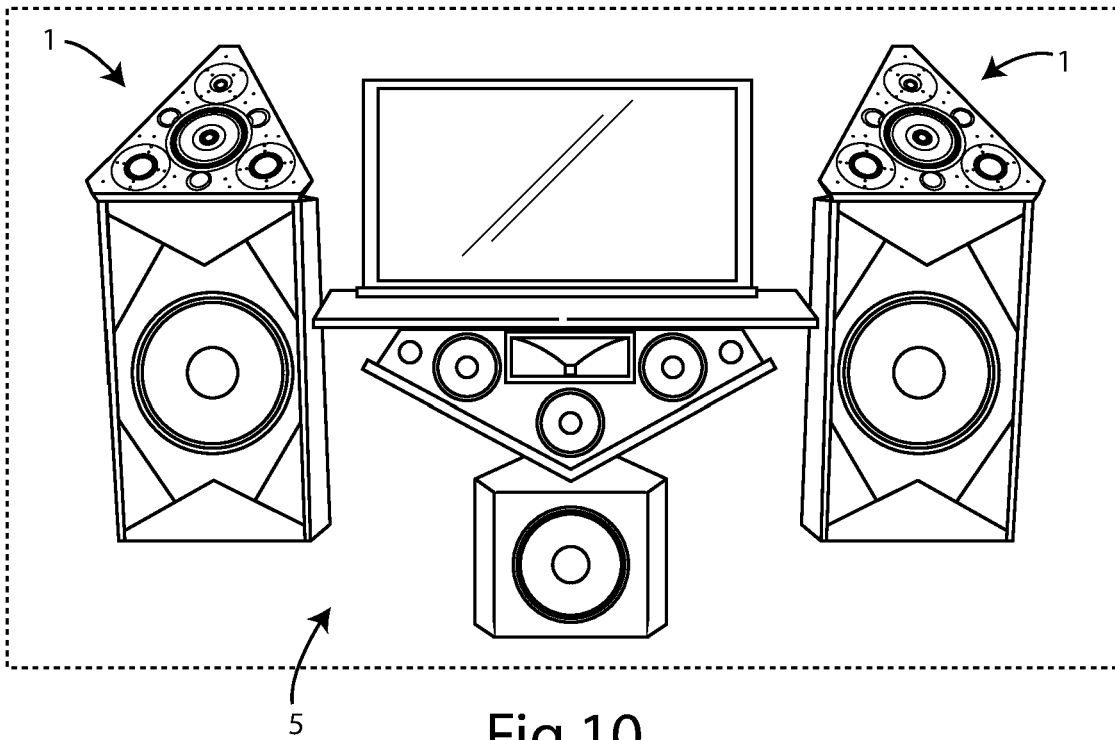

Fig.10

REFERENCES CITED IN THE DESCRIPTION

This list of references cited by the applicant is for the reader's convenience only. It does not form part of the European patent document. Even though great care has been taken in compiling the references, errors or omissions cannot be excluded and the EPO disclaims all liability in this regard.

Patent documents cited in the description

- GB 1303602 A [0018]
- US 2010177921 A [0018]
- US 2012195447 A1 [0018]
- US 8967323 B1 [0018]
- EP 0521655 A1 [0018]