



US 20150174405A1

(19) **United States**
(12) **Patent Application Publication**
KILGARD et al.

(10) **Pub. No.: US 2015/0174405 A1**
(43) **Pub. Date: Jun. 25, 2015**

(54) **SYSTEMS, METHODS AND DEVICES FOR TREATING TINNITUS**

filed on Aug. 4, 2008, provisional application No. 61/149,387, filed on Feb. 3, 2009.

(71) Applicant: **MicroTransponder, Inc.**, Austin, TX (US)

Publication Classification

(72) Inventors: **Michael P. KILGARD**, Richardson, TX (US); **Larry CAULLER**, Plano, TX (US); **Navzer ENGINEER**, Plano, TX (US); **Christa McIntyre Rodriguez**, Richardson, TX (US); **Will ROSELLINI**, Dallas, TX (US)

(51) **Int. Cl.**
A61N 1/36 (2006.01)
A61M 21/02 (2006.01)
(52) **U.S. Cl.**
CPC *A61N 1/36032* (2013.01); *A61M 21/02* (2013.01); *A61M 2021/0027* (2013.01)

(21) Appl. No.: **14/579,438**

(57) **ABSTRACT**

(22) Filed: **Dec. 22, 2014**

Systems, methods and devices for paired training include timing controls so that training and neural stimulation can be provided simultaneously. Paired trainings may include therapies, rehabilitation and performance enhancement training. Stimulations of nerves such as the vagus nerve that affect subcortical regions such as the nucleus basalis, locus coeruleus or amygdala induce plasticity in the brain, enhancing the effects of a variety of therapies, such as those used to treat tinnitus, stroke, traumatic brain injury and post-traumatic stress disorder.

Related U.S. Application Data

(63) Continuation of application No. 12/485,860, filed on Jun. 16, 2009, now Pat. No. 8,934,967.
(60) Provisional application No. 61/077,648, filed on Jul. 2, 2008, provisional application No. 61/078,954, filed on Jul. 8, 2008, provisional application No. 61/086,116,

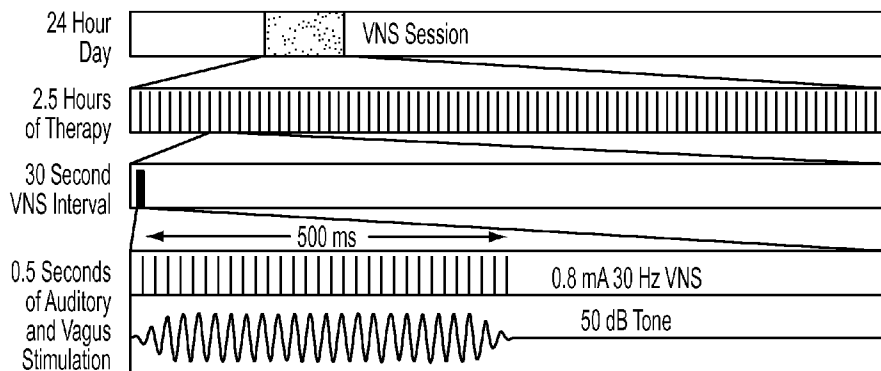
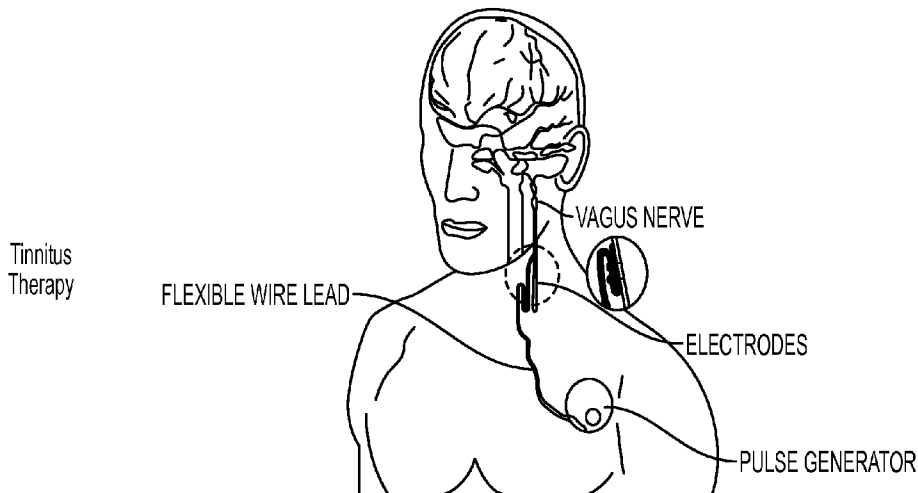

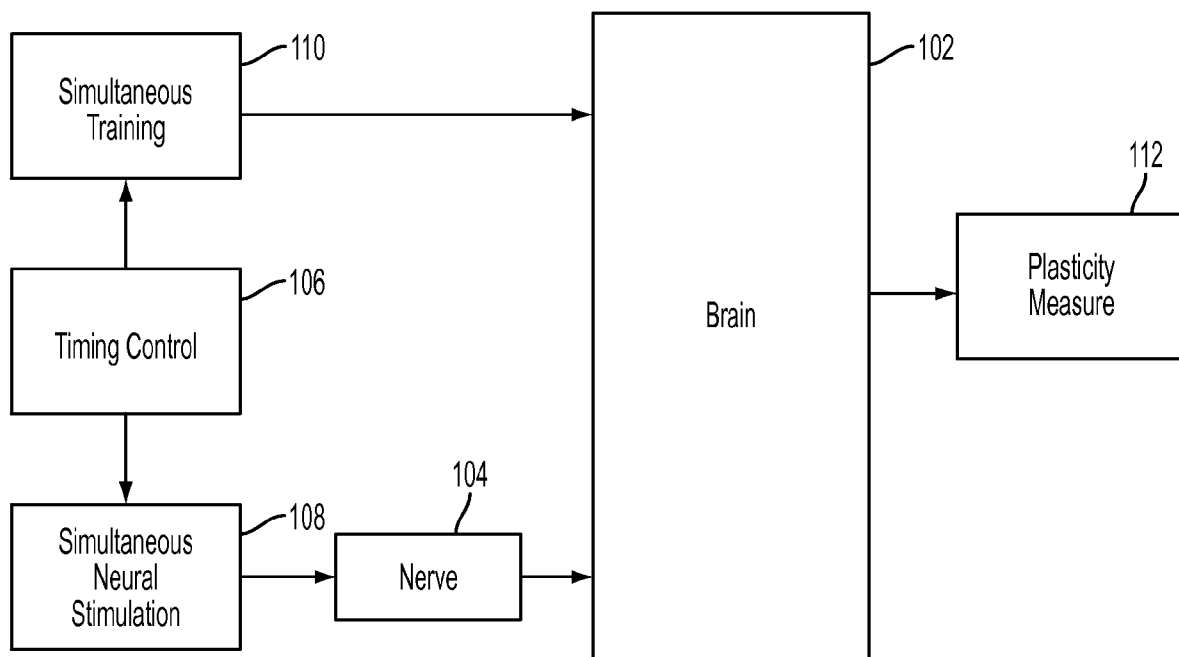

FIG. 1

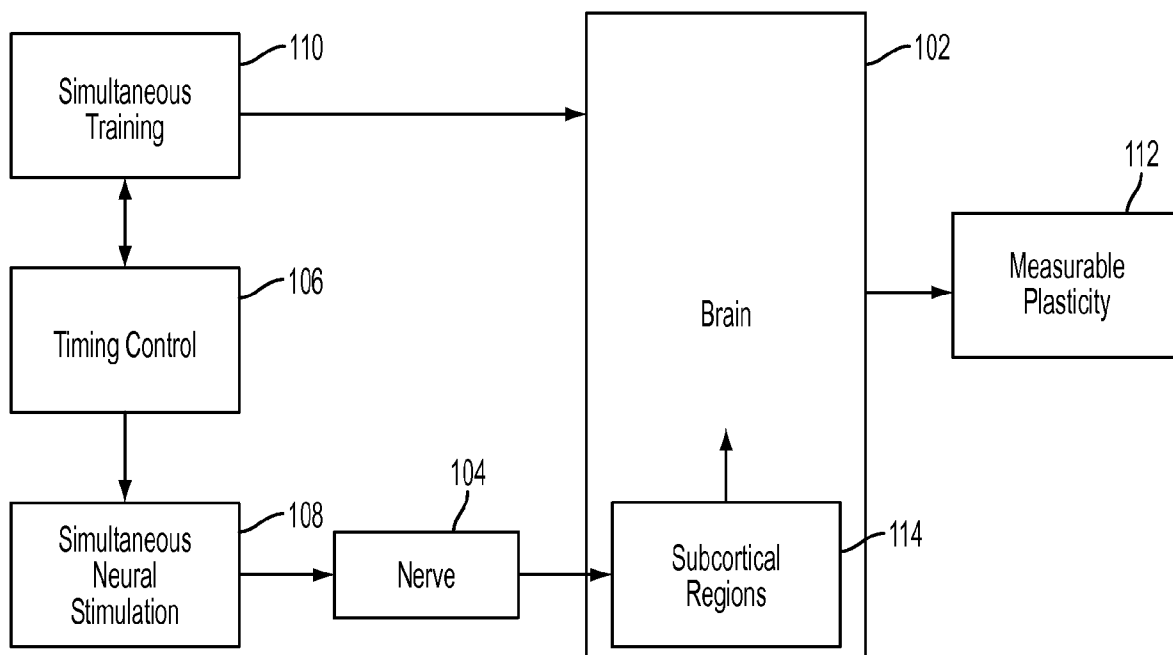

FIG. 2

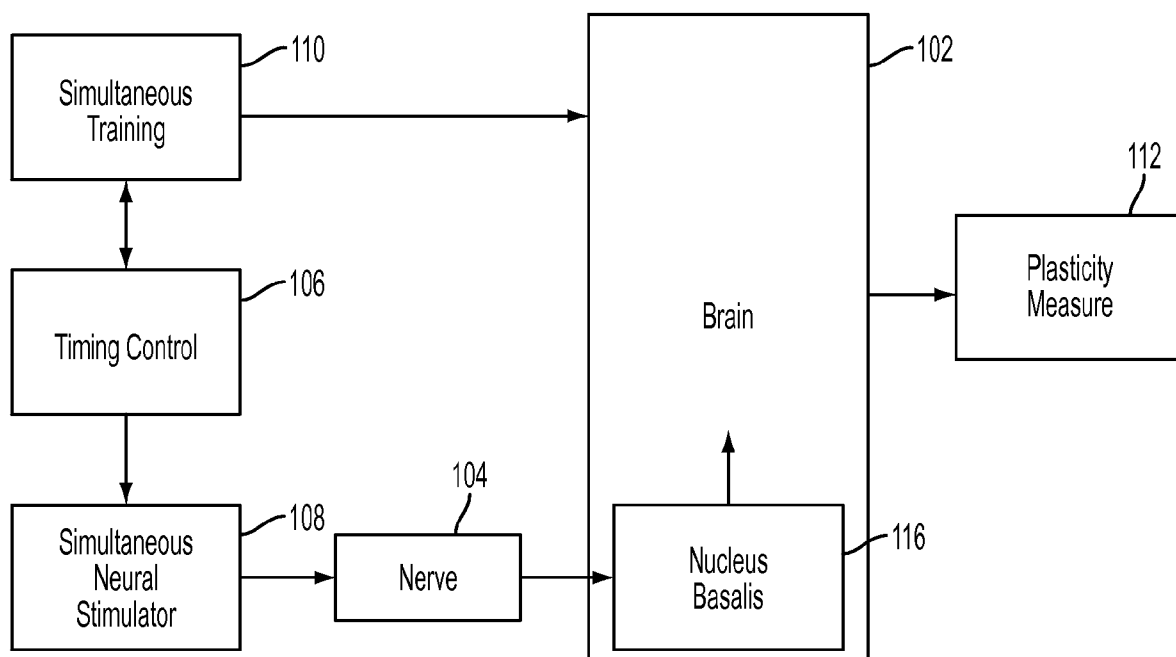

FIG. 3

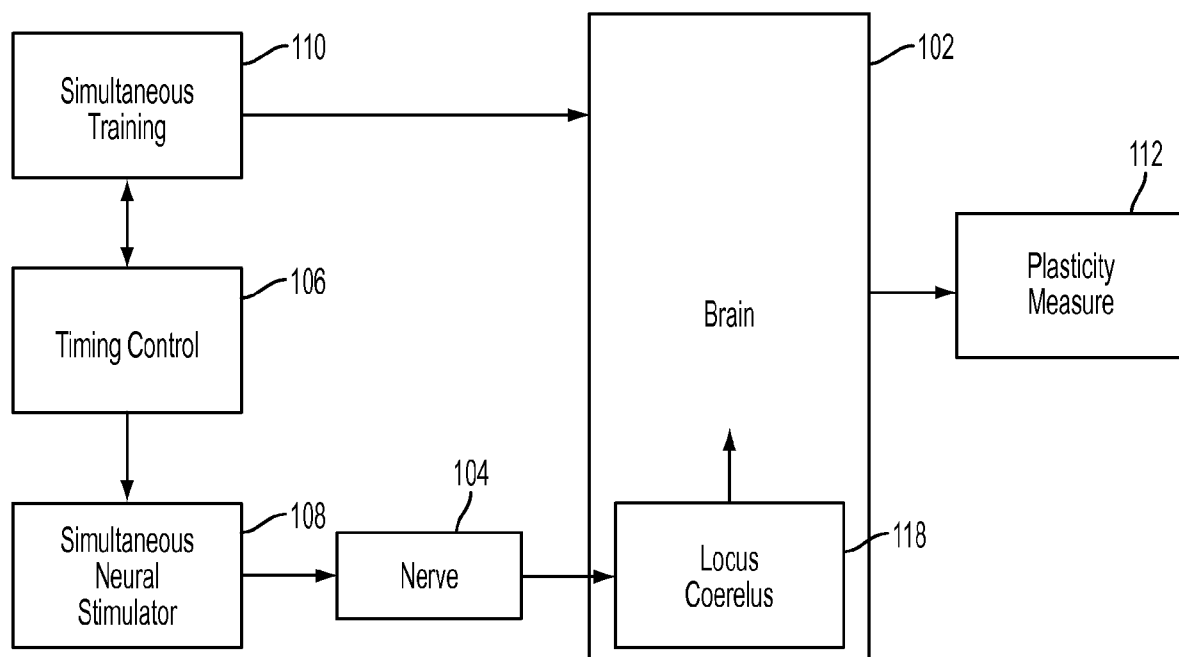

FIG. 4

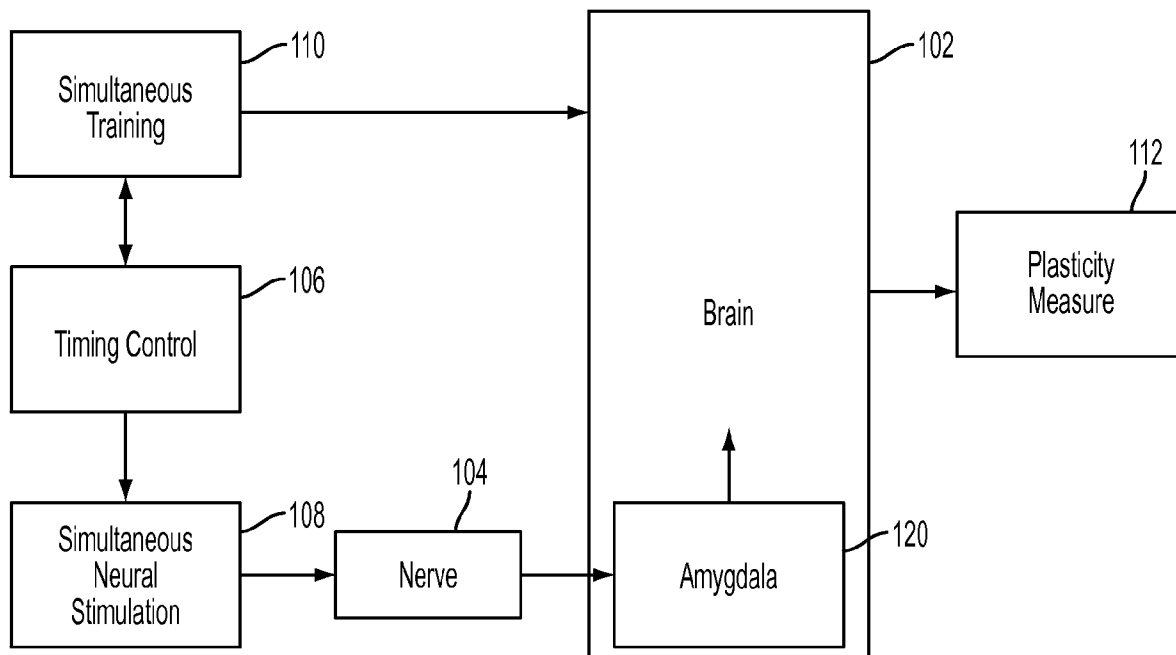

FIG. 5

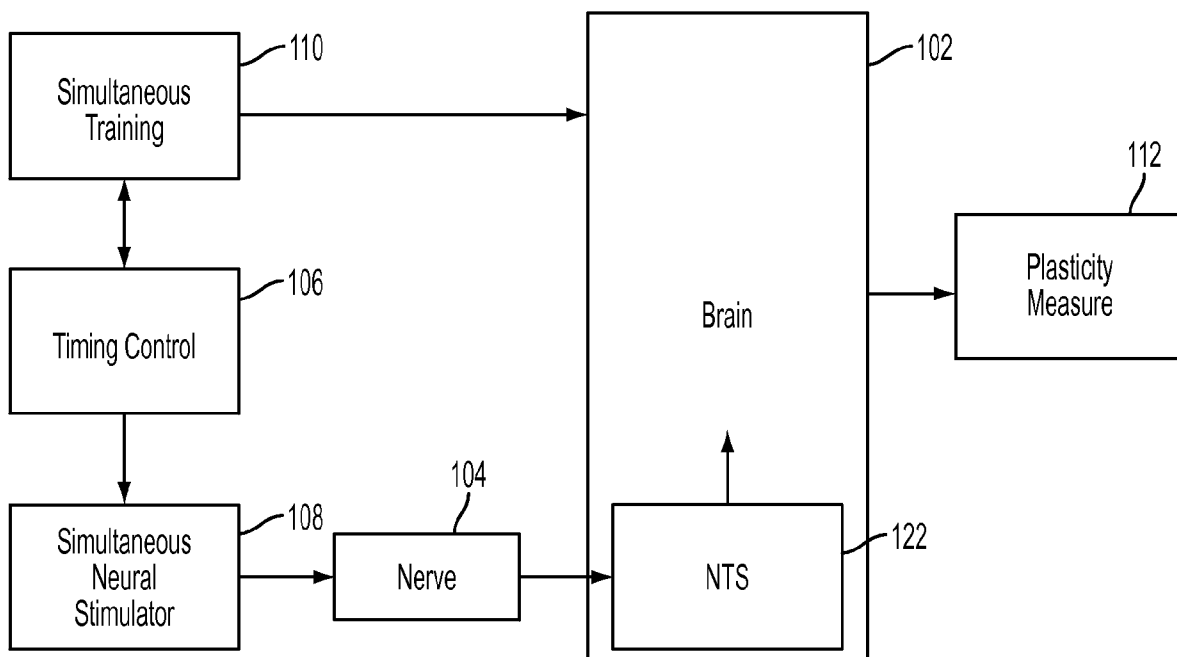

FIG. 6

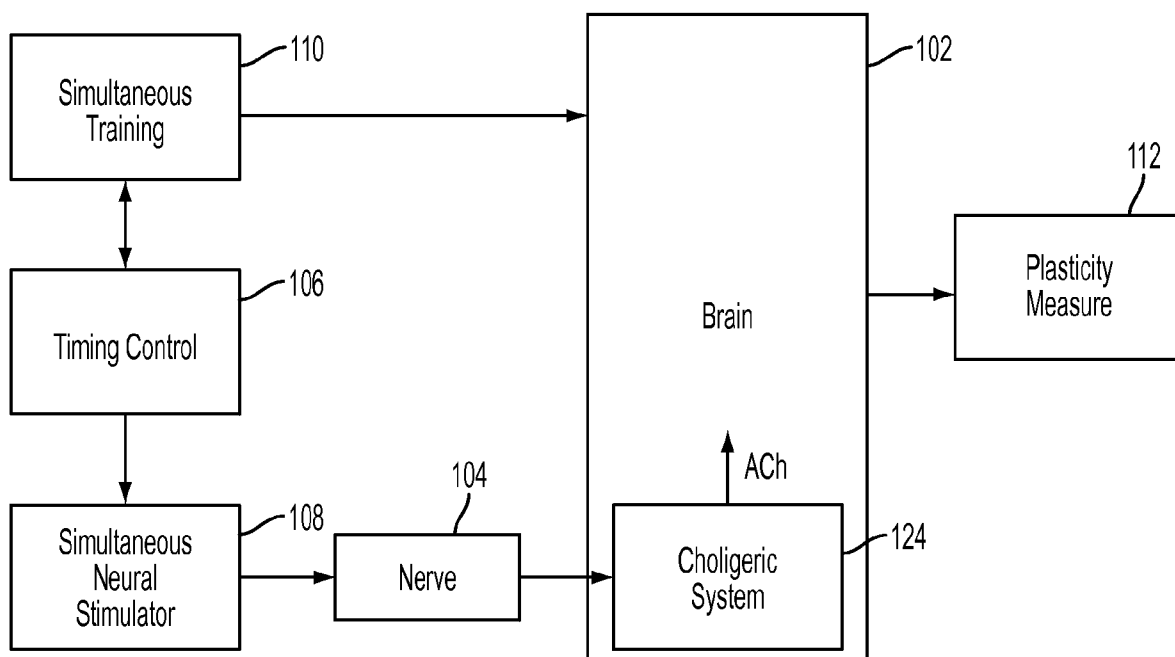

FIG. 7

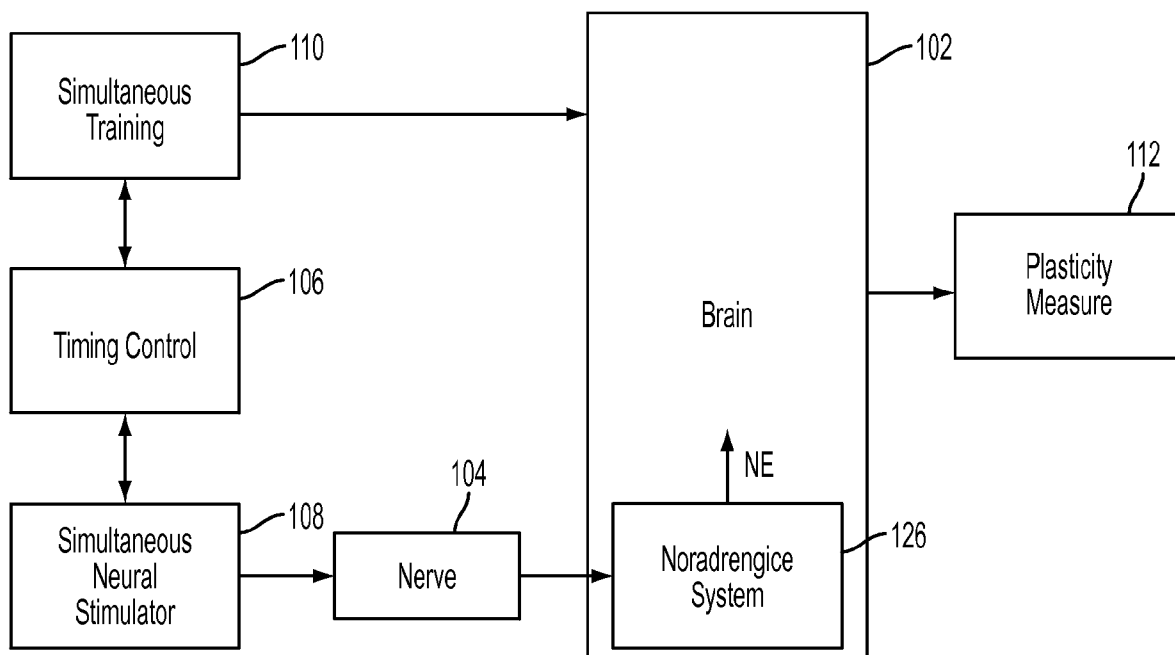

FIG. 8

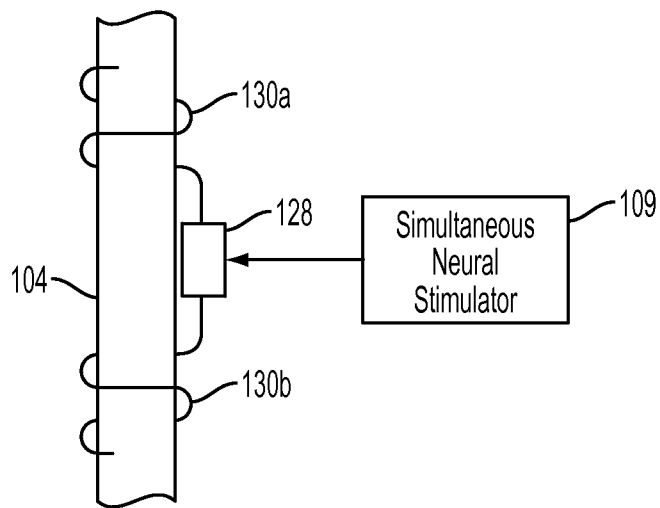

FIG. 9

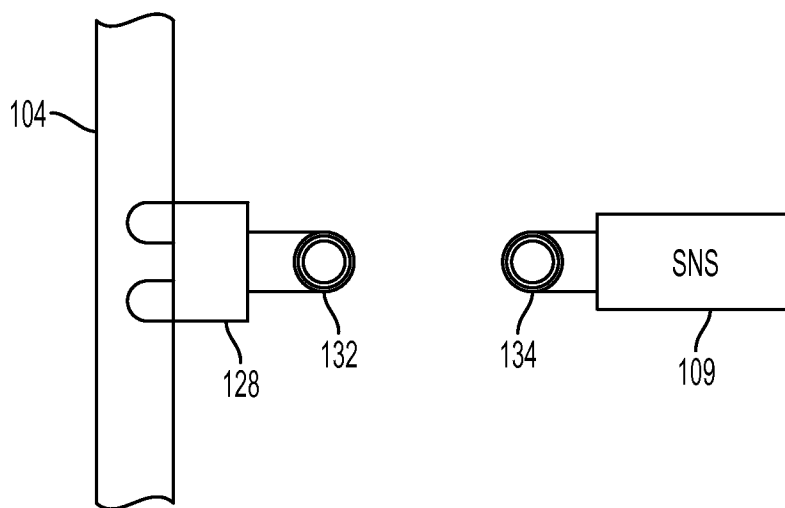

FIG. 10

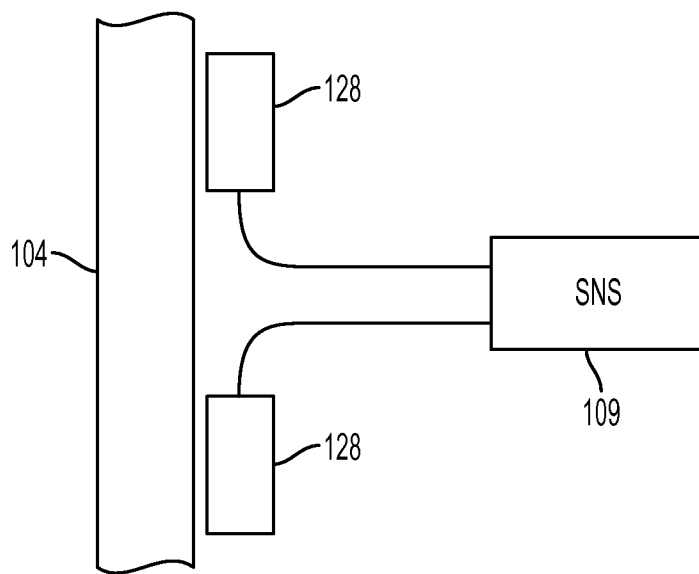

FIG. 11

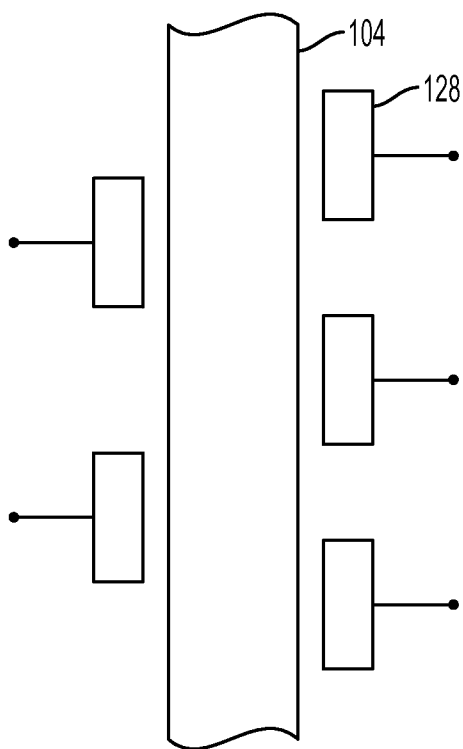

FIG. 12

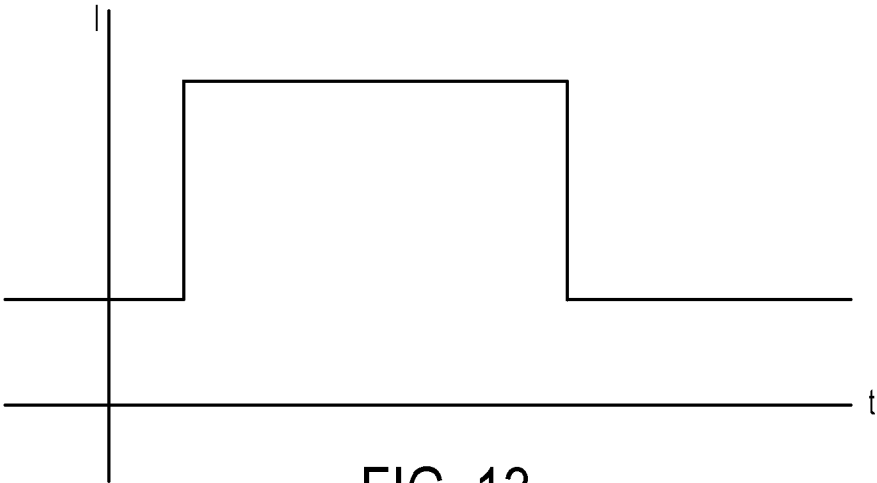

FIG. 13

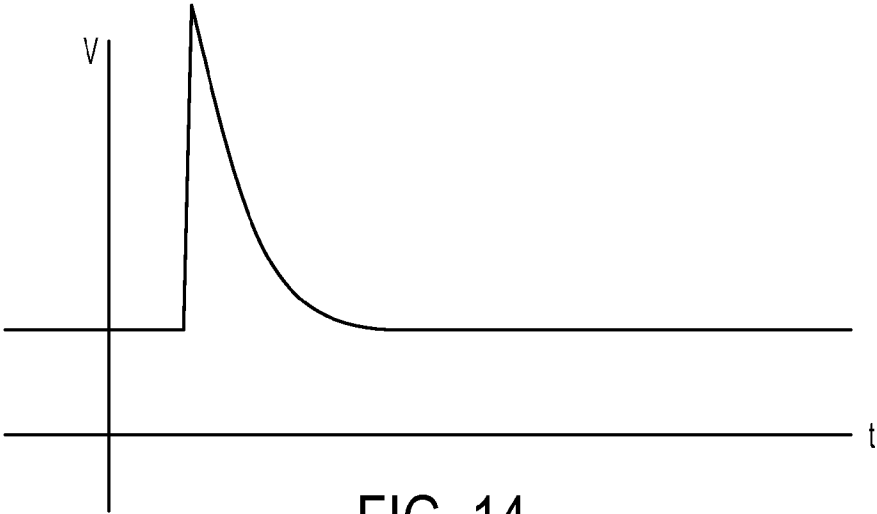

FIG. 14

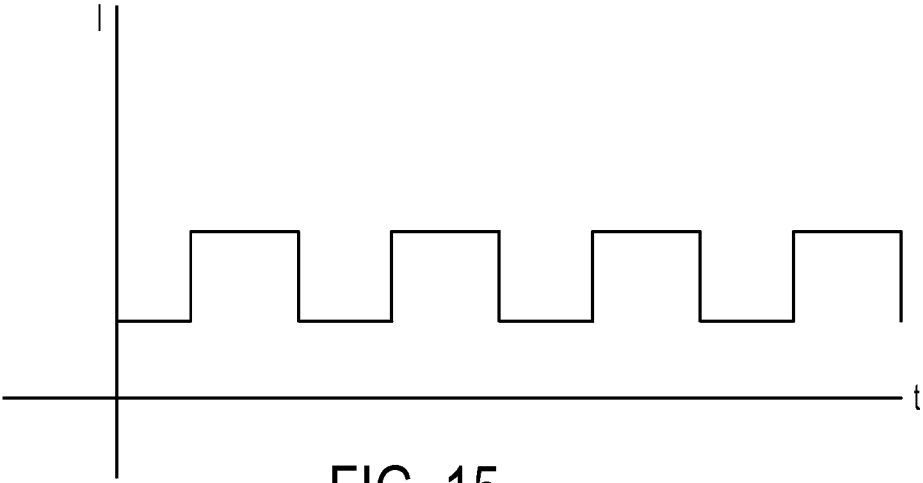

FIG. 15

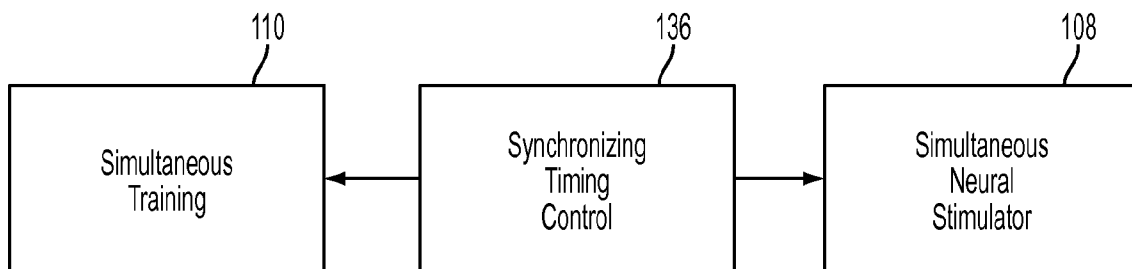

FIG. 16

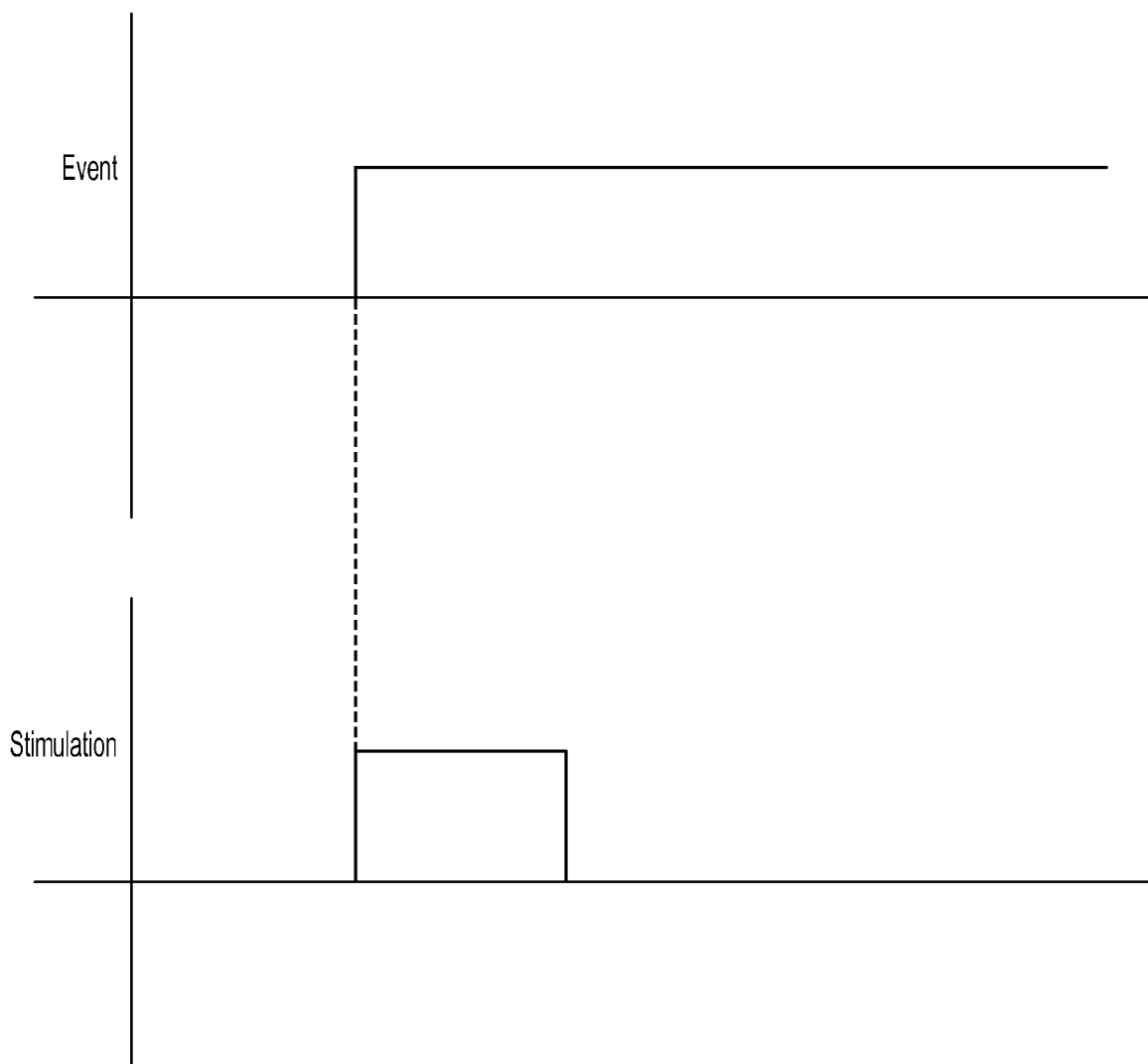

FIG. 17

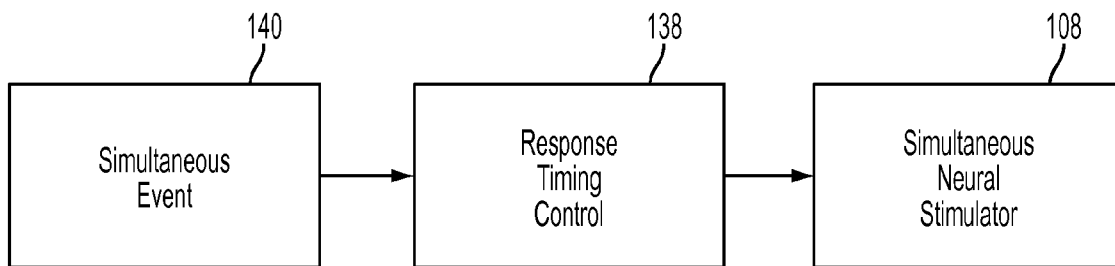

FIG. 18

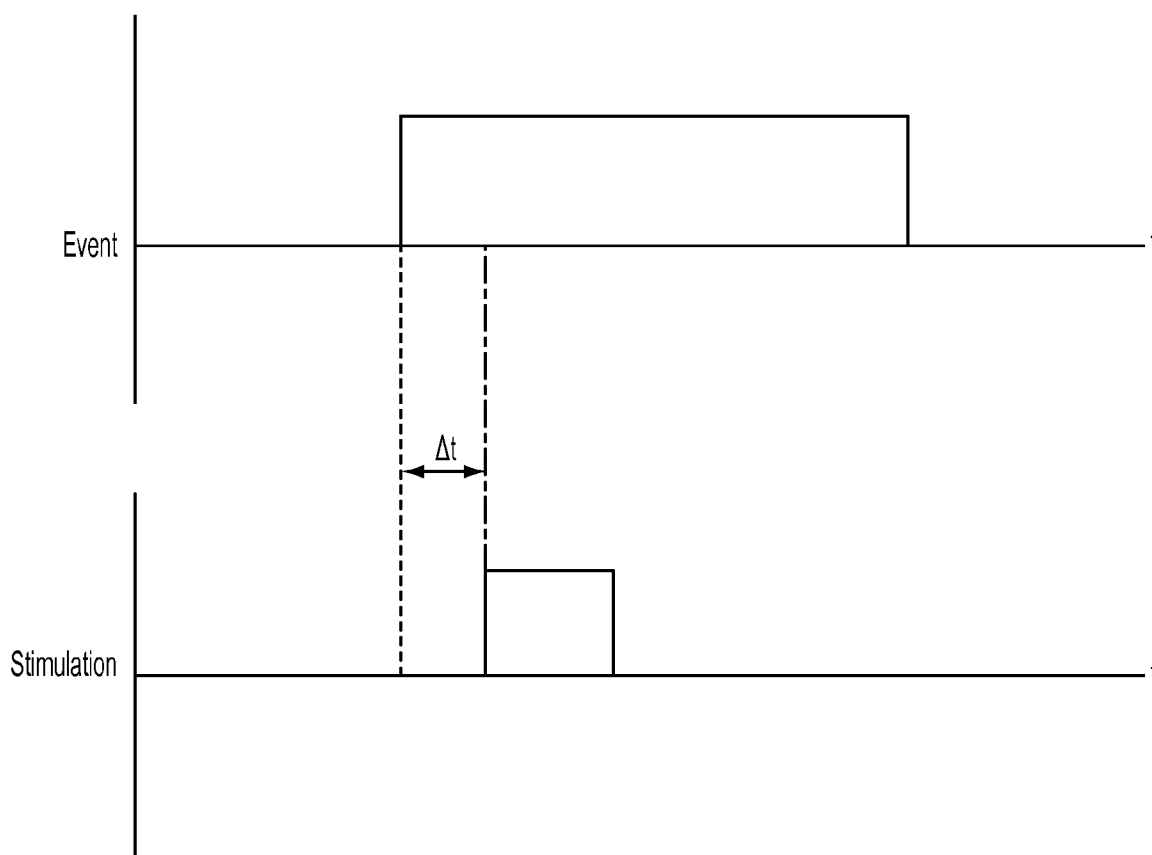

FIG. 19

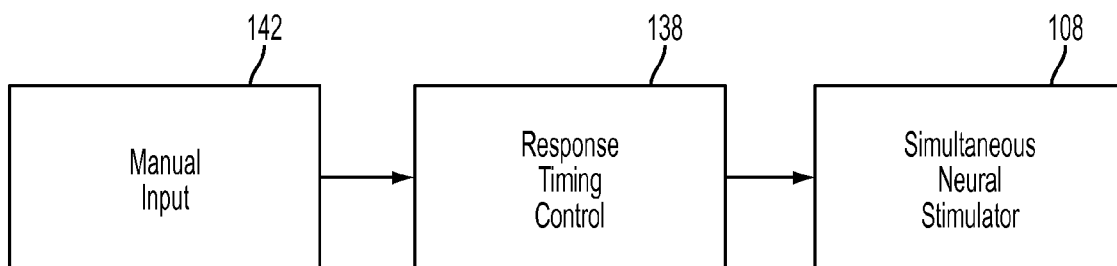

FIG. 20

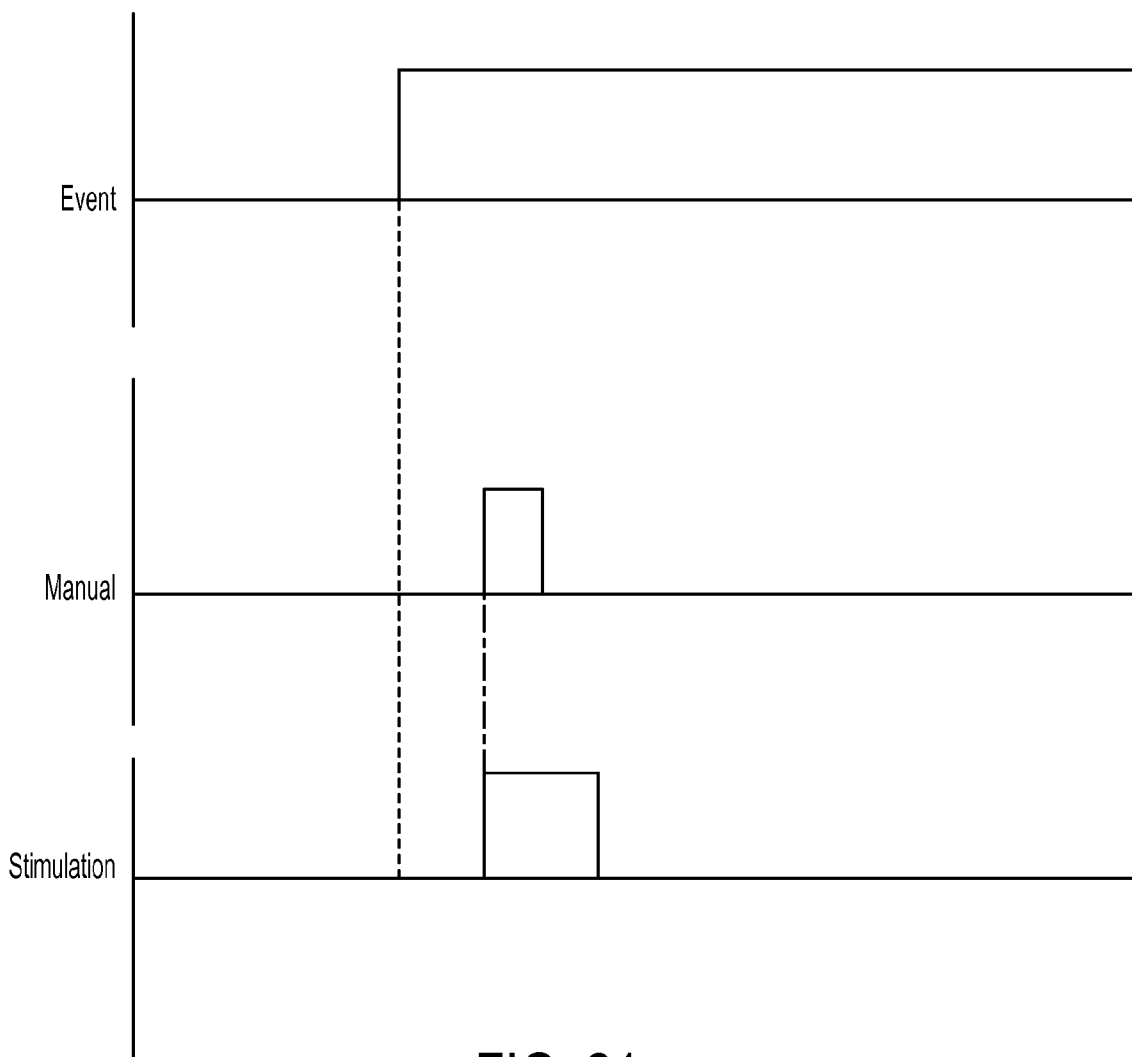

FIG. 21

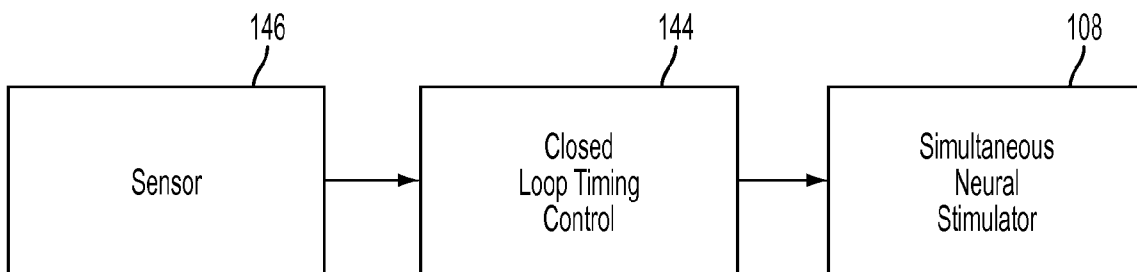

FIG. 22

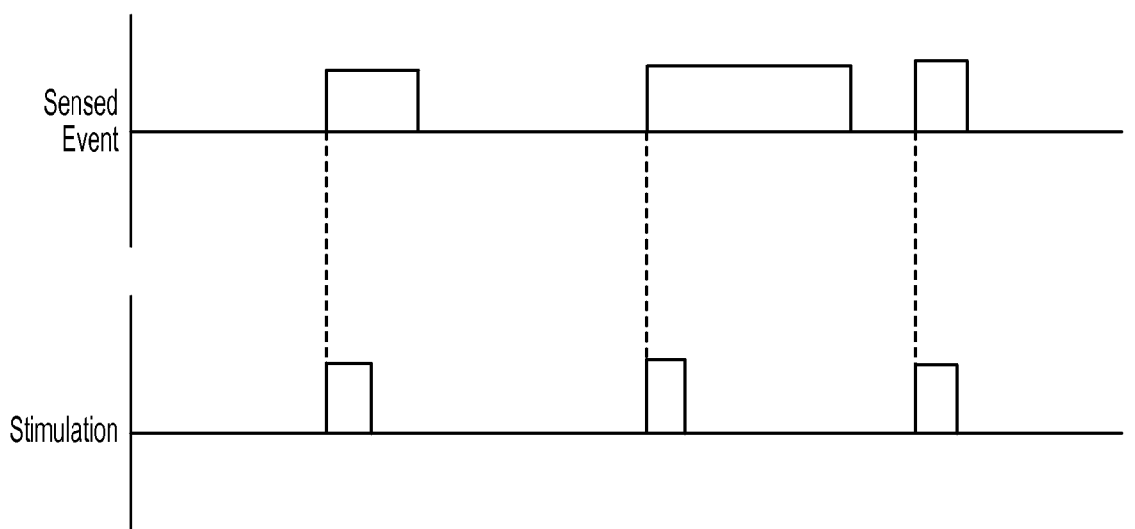

FIG. 23

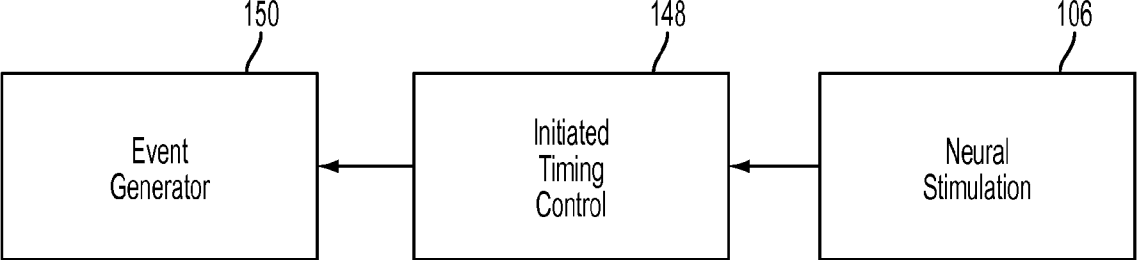

FIG. 24

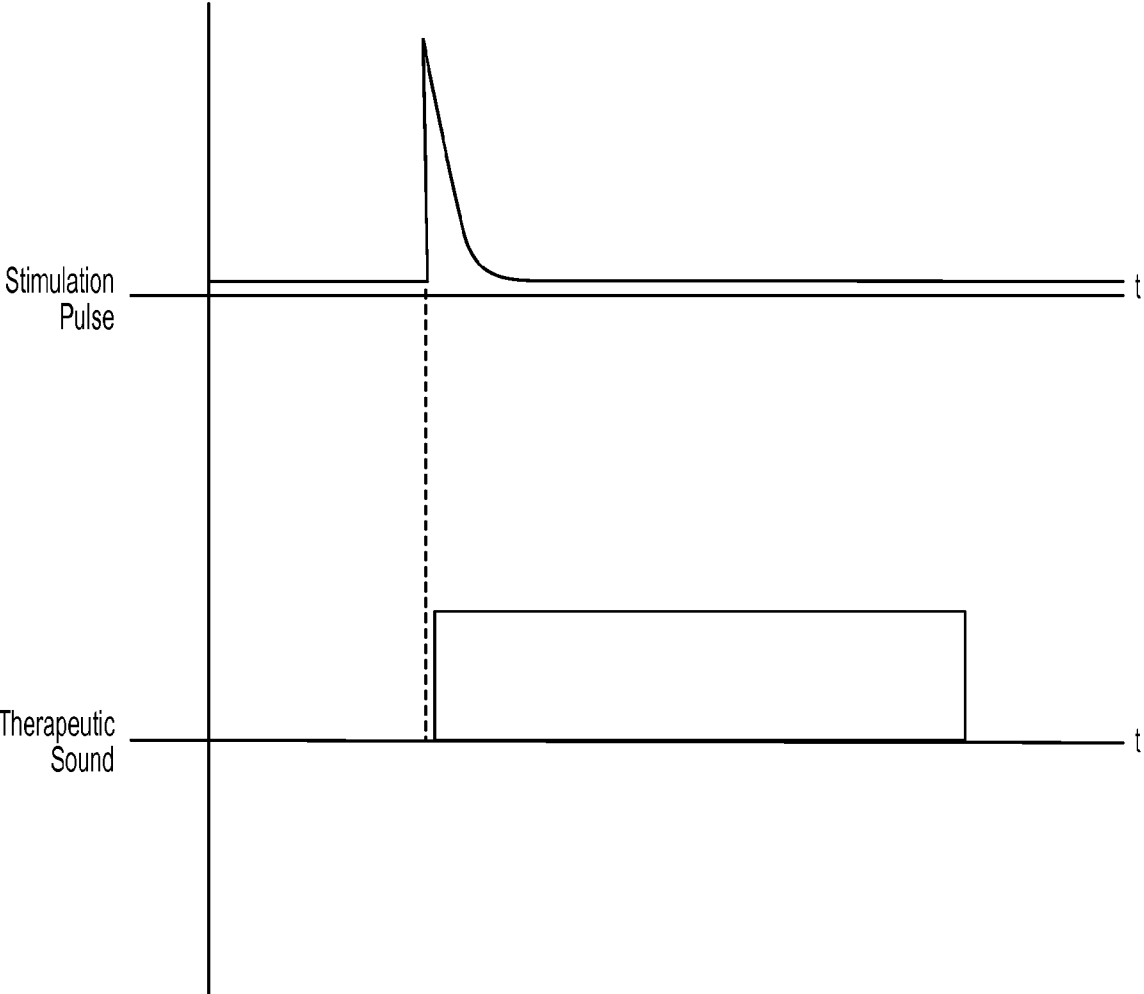

FIG. 25

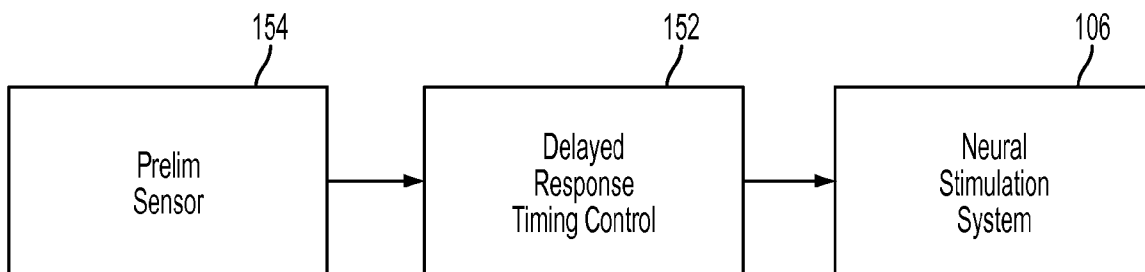

FIG. 26

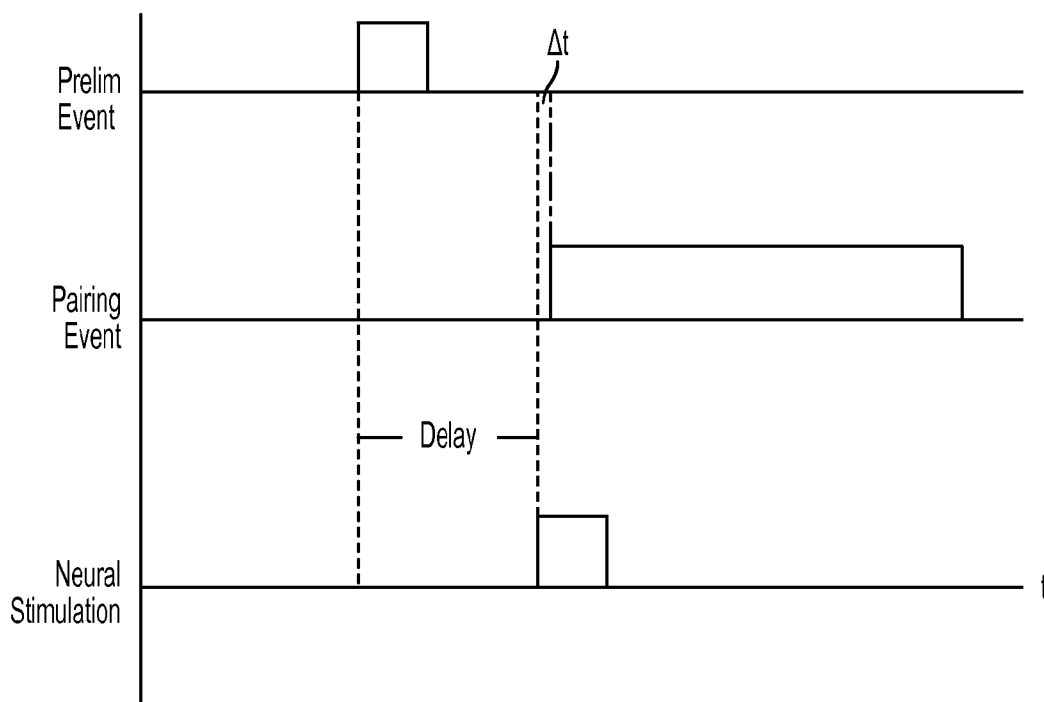

FIG. 27

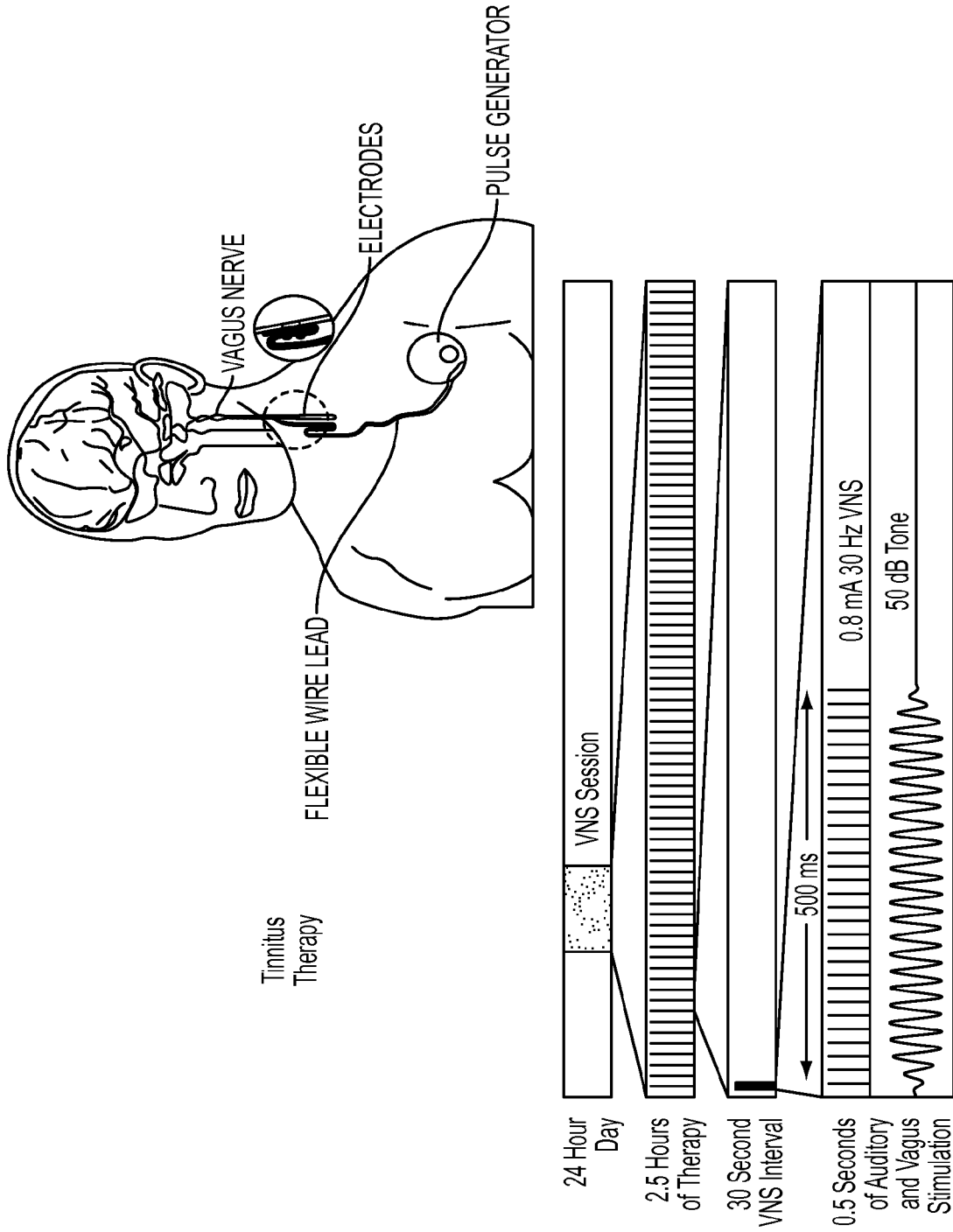

FIG. 28

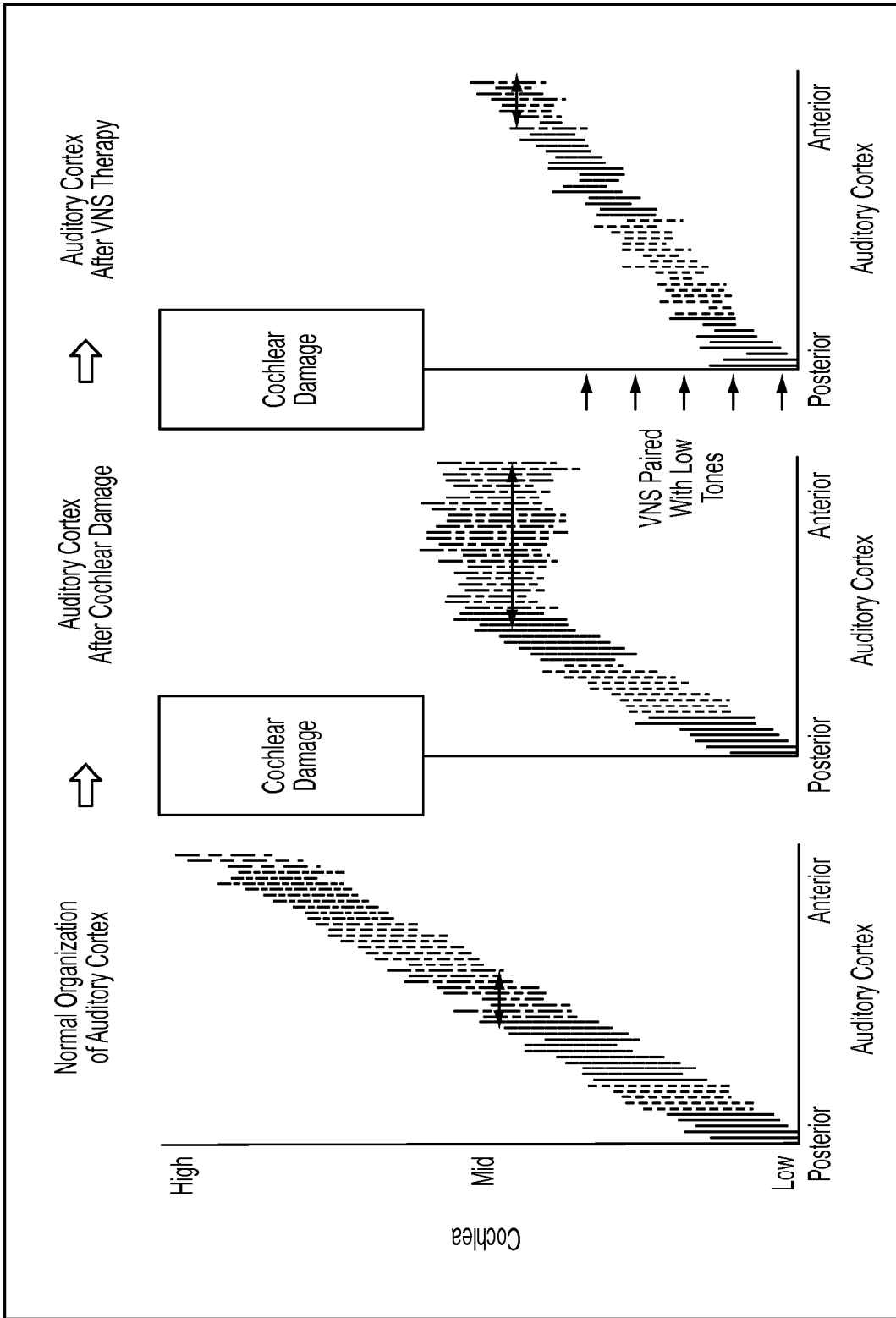

FIG. 29

SYSTEMS, METHODS AND DEVICES FOR TREATING TINNITUS

PRIORITY CLAIM

[0001] The present application is a continuation of U.S. patent application Ser. No. 12/485,860, filed Jun. 16, 2009, of which claims priority benefits under 35 U.S.C. §119(e) from U.S. Provisional Application No. 61/077,648, filed on Jul. 2, 2008 and entitled "Treatment of Tinnitus with Vagus Nerve Stimulation"; U.S. Provisional Application No. 61/078,954, filed on Jul. 8, 2008 and entitled "Neuroplasticity Enhancement"; U.S. Provisional Application No. 61/086,116, filed on Aug. 4, 2008 and entitled "Tinnitus Treatment Methods and Apparatus"; and U.S. Provisional Application No. 61/149,387, filed on Feb. 3, 2009 and entitled "Healing the Human Brain: The Next Medical Revolution." The present application incorporates the foregoing disclosures herein by reference.

BACKGROUND

[0002] The present disclosure relates generally to therapy, rehabilitation and training including induced plasticity. More particularly, the disclosure relates to methods and systems of enhancing therapy, rehabilitation and training using nerve stimulation paired with training experiences.

SUMMARY

[0003] For purposes of summarizing the invention, certain aspects, advantages, and novel features of the invention have been described herein. It is to be understood that not necessarily all such advantages may be achieved in accordance with any particular embodiment of the invention. Thus, the invention may be embodied or carried out in a manner that achieves or optimizes one advantage or group of advantages as taught herein without necessarily achieving other advantages as may be taught or suggested herein.

BRIEF DESCRIPTION OF THE DRAWINGS

[0004] The disclosed inventions will be described with reference to the accompanying drawings, which show important sample embodiments of the invention and which are incorporated in the specification hereof by reference, wherein:

[0005] FIG. 1 is a block diagram depicting a paired training system, in accordance with an embodiment;

[0006] FIG. 2 is a block diagram depicting a paired training system affecting a sub-cortical region, in accordance with an embodiment;

[0007] FIG. 3 is a block diagram depicting a paired training system affecting the nucleus basalis, in accordance with an embodiment;

[0008] FIG. 4 is a block diagram depicting a paired training system affecting the locus coeruleus, in accordance with an embodiment;

[0009] FIG. 5 is a block diagram depicting a paired training system affecting the amygdala, in accordance with an embodiment;

[0010] FIG. 6 is a block diagram depicting a paired training system affecting the nucleus of the solitary tract (NTS), in accordance with an embodiment;

[0011] FIG. 7 is a block diagram depicting a paired training system affecting the cholinergic system, in accordance with an embodiment;

[0012] FIG. 8 is a block diagram depicting a paired training system affecting the noradrenergic system, in accordance with an embodiment;

[0013] FIG. 9 is a simplified diagram depicting a stimulator, in accordance with an embodiment;

[0014] FIG. 10 is a simplified diagram depicting a wireless stimulator, in accordance with an embodiment;

[0015] FIG. 11 is a simplified diagram depicting a dual stimulator configuration, in accordance with an embodiment;

[0016] FIG. 12 is a simplified diagram depicting a multi-stimulator configuration, in accordance with an embodiment;

[0017] FIG. 13 is a graph depicting a constant current stimulation pulse, in accordance with an embodiment;

[0018] FIG. 14 is a graph depicting an exponential stimulation pulse, in accordance with an embodiment;

[0019] FIG. 15 is a graph depicting a train of constant current stimulation pulses, in accordance with an embodiment;

[0020] FIG. 16 is a block diagram depicting a synchronizing control system, in accordance with an embodiment;

[0021] FIG. 17 is a graph depicting synchronized pairing, in accordance with an embodiment;

[0022] FIG. 18 is a block diagram depicting a response control system, in accordance with an embodiment;

[0023] FIG. 19 is a graph depicting response pairing, in accordance with an embodiment;

[0024] FIG. 20 is a block diagram depicting a manual control system, in accordance with an embodiment;

[0025] FIG. 21 is a graph depicting manual pairing, in accordance with an embodiment;

[0026] FIG. 22 is a block diagram depicting a closed loop control system, in accordance with an embodiment;

[0027] FIG. 23 is a graph depicting closed loop pairing, in accordance with an embodiment;

[0028] FIG. 24 is a block diagram depicting an initiated control system, in accordance with an embodiment;

[0029] FIG. 25 is a graph depicting initiated pairing, in accordance with an embodiment;

[0030] FIG. 26 is a block diagram depicting a delayed response timing control system, in accordance with an embodiment;

[0031] FIG. 27 is a graph depicting delayed response pairing, in accordance with an embodiment;

[0032] FIG. 28 depicts a tinnitus therapy, in accordance with an embodiment; and

[0033] FIG. 29 depicts a schematic illustration of the proposed tinnitus pathology and treatment.

DETAILED DESCRIPTION OF THE DRAWINGS

[0034] The numerous innovative teachings of the present application will be described with particular reference to presently preferred embodiments (by way of example, and not of limitation). The present application describes several inventions, and none of the statements below should be taken as limiting the claims generally. Where block diagrams have been used to illustrate the invention, it should be recognized that the physical location where described functions are performed are not necessarily represented by the blocks. Part of a function may be performed in one location while another part of the same function is performed at a distinct location. Multiple functions may be performed at the same location.

[0035] With reference to FIG. 1, a paired training system is shown. A timing control system 106 is communicably connected to a neural stimulator system 108 and a training system

110. Receiving timing instruction from the timing control system **106**, the neural stimulator system **108** provides stimulation to a nerve **104**. Similarly receiving timing instruction from the timing control system **106**, or providing timing instruction to the timing control system, the training system **110** generates desired mental images, ideas, formations or states in the brain **102**. The stimulation of the nerve **104** affects the brain **102** by inducing plasticity. The temporally paired combination of training and stimulation generates manifestations of plasticity in the brain **102** that may be measured by a plasticity measure system **112**.

[0036] The timing controls system **106** generally provides the simultaneous nature of the pairing. The stimulation and the training are simultaneous in that they occur at the same time, that is, there is at least some overlap in the timing. In some embodiments, the stimulation may lead the start of the training while in other embodiments, the stimulation may follow the start of the training. In many cases, the stimulation is shorter in duration than the training, such that the stimulation occurs near the beginning of the training. Plasticity resulting from stimulation has been shown to last minutes or hours, so a single stimulation pulse may suffice for the whole duration of extended training.

[0037] In the treatment of tinnitus, for example, the training may consist of brief audible sounds including selected therapeutic frequencies, paired with stimulations. Because the duration of the sounds may be short, the timing may be controlled very precisely so that the sound coincides temporally with the stimulation. This kind of precision may typically require some form of computer control. In other forms of rehabilitation or education, the timing of the training and/or the stimulation may be controlled manually. Further therapies and training may include training triggered timing or physical condition feedback to provide a closed-loop system.

[0038] The neural stimulation system **108** may provide stimulation of the nerve **104** using electrical stimulation, chemical stimulation, magnetic stimulation, optical stimulation, mechanical stimulation or any other form of suitable nerve stimulation. In accordance with an embodiment, an electrical stimulation is provided to the left vagus nerve. In an electrical stimulation system, suitable stimulation pulses may include a variety of waveforms, including constant current pulses, constant voltage pulses, exponential pulses or any other appropriate waveform. An electrical stimulation system may use a single stimulation pulse or a train of stimulation pulses to stimulate the nerve **104**. Stimulation parameters are selected to affect the brain **102** appropriately, with reference to the affected brain regions or systems, plasticity measures, desynchronization or any other appropriate stimulation parameter measure. A half second train of biphasic stimulation pulses, with a pulse width of 100 microseconds, at 0.8 milliamps and at 30 Hz has been used effectively in the treatment of tinnitus.

[0039] Paired stimulation could be accomplished using deep brain stimulation, cortical stimulation, transcranial magnetic stimulation and any other suitable neural stimulation.

[0040] One indication of appropriate stimulation may be desynchronization of the cortical EEG. A 0.8 milliamp pulse has been shown to cause cortical desynchronization at frequencies between 30 and 150 Hz. 0.4 milliamp pulses desynchronize the cortex at higher frequencies of 100 to 150 Hz. Desynchronization has been shown to last for at least four seconds in response to stimulation of the vagus nerve.

[0041] The simultaneous training system **110** generates the sensory input, motor sequences, cognitive input, mental images, ideas, formations or states that are to be retained by the brain **102**. A training system **110** may provide sensory information, such as visual, auditory, olfactory, tactile or any other suitable sensory information. Training system **110** may include physical therapies, cognitive therapies, emotional therapies, chemical therapies, or any other suitable therapies. Training system **110** may present educational information. Training system **110** may include the subject, physically, mentally, emotionally or in any other suitable fashion. Training system **110** may include teachers, doctors, therapists, counselors, instructors, coaches or any other suitable training provider. Training system **110** may evoke specific patterns of neural activity by direct brain stimulation, for example by electrical, magnetic, optical, or any other suitable pattern evocation systems. Training system **110** may inactivate specific brain regions via chemical agents, cooling, magnetic stimulation, or other suitable methods.

[0042] The paired training system of FIG. 1 affects the brain **102** to generate plasticity that can be measured by a plasticity measure system **112**. In the treatment of tinnitus, a cortical map may be used to measure the map distortion and correction that accompanies the successful treatment of tinnitus. Less invasively, the plasticity can be measured by behaviorally reactions to stimuli, such as a startle test for tinnitus. Further, plasticity can be measured by inquiring about the subjective experience of a subject. If a tinnitus patient no longer experiences a persistent noise, plasticity has been measured.

[0043] With reference to FIG. 2, a paired training system affecting a subcortical region **114** of the brain **102**, in accordance with an embodiment is shown. The stimulation of nerve **104** affects a subcortical region **114**. The subcortical region **114**, in turn, affects the brain to induce plasticity. Stimulation of nerves **104** such as the trigeminal nerve and other cranial nerves are known to affect the subcortical region **114**.

[0044] With reference to FIG. 3, a paired training system affecting the nucleus basalis **116**, in accordance with an embodiment, is shown. The stimulation of nerve **104** affects the nucleus basalis **116**. The nucleus basalis, in turn, affects the brain **102** to induce plasticity.

[0045] With reference to FIG. 4, a paired training system affecting the locus coeruleus **118**, in accordance with an embodiment, is shown. The stimulation of nerve **104** affects the locus coeruleus **118**. The locus coeruleus **118**, in turn, affects the brain **102** to induce plasticity.

[0046] With reference to FIG. 5, a paired training system affecting the amygdala **120**, in accordance with an embodiment, is shown. The stimulation of nerve **104** affects the amygdala **120**. The amygdala **120**, in turn, affects the brain **102** to induce plasticity.

[0047] With reference to FIG. 6, a paired training system affecting the NTS **122**, in accordance with an embodiment, is shown. The stimulation of nerve **104** affects the NTS **122**. The NTS **122**, in turn, affects the brain **102** to induce plasticity.

[0048] With reference to FIG. 7, a paired training system affecting the cholinergic system **124**, in accordance with an embodiment, is shown. The stimulation of nerve **104** affects the cholinergic system **124**. The cholinergic system **124** releases acetylcholine (ACh) into the brain **102** inducing plasticity.

[0049] With reference to FIG. 8, a paired training system affecting the noradrenergic system **126**, in accordance with

an embodiment, is shown. The stimulation of nerve **104** affects the noradrenergic system **126**. The noradrenergic system **126** releases noradrenaline (NE) into the brain **102** inducing plasticity.

[0050] With reference to FIG. 9, a neural stimulator system, in accordance with an embodiment, is shown. A neural stimulator control **109** is communicably connected to a neurostimulator **128**. Neurostimulator **128** provides a stimulation pulse to a nerve **104** via a pair of electrodes **130a** and **130b**. Electrodes **103a** and **130b** could be cuff electrodes, conductive plates or any other suitable neural stimulation electrode. The neurostimulator may be powered by a piezoelectric powering system as well as near field inductive power transfer, far-field inductive power transfer, battery, rechargeable battery or any other suitable neurostimulator power system. When neural stimulator control **109** receives timing instructions from a timing control system (not shown), the neural stimulator control **109** initiates a stimulation pulse from the neurostimulator **128** via electrodes **130a** and **130b**.

[0051] With reference to FIG. 10, a wireless neural stimulator system, in accordance with an embodiment is shown. Neurostimulator **128** communicates with the neural stimulation system **109** using an inductive transponder coil **132**. The neural stimulator system **109** includes an external coil **134**. Information may be communicated between the neural stimulator system **109** and the neurostimulator **128**. Power may be transferred to the neurostimulator **128** by the neural stimulator system.

[0052] With reference to FIG. 11, a dual neurostimulator system, in accordance with an embodiment, is shown. Two neurostimulators **128** may stimulate neural **104**. The neurostimulators may be controlled to reinforce each other, as redundancy, or to prevent efferent signals from projecting away from the brain.

[0053] With reference to FIG. 12, a multi-neurostimulator system, in accordance with an embodiment, is shown. A plurality of neurostimulators **128** may stimulate nerve **104**. The neurostimulators may be controlled to reinforce each other, as redundancy, or to prevent efferent signals from projecting away from the brain.

[0054] With reference to FIG. 13, a graph shows a constant current stimulation pulse, in accordance with an embodiment.

[0055] With reference to FIG. 14, a graph shows an exponential stimulation pulse, in accordance with an embodiment.

[0056] With reference to FIG. 15, a graph shows a train of constant current stimulation pulses, in accordance with an embodiment.

[0057] With reference to FIG. 16, a synchronized timing control system, in accordance with an embodiment, is shown. The synchronized timing control system includes a synchronizing timing control **186**. The synchronizing timing control **186** is communicably connected to the neural stimulation system **108** and the training system **110**. The synchronizing timing control **136** provides timing instructions to the neural stimulation system **108** and the training system **110** so that the stimulation and training occur simultaneously. In the treatment of tinnitus, the stimulation of the nerve may slightly precedes each training sound, to give the stimulation time to affect the brain when the training sound is presented. Further embodiments may include other suitable timing variations.

[0058] With reference to FIG. 17, a graph shows a possible timing relationship between event and stimulation for a synchronized timing control system.

[0059] With reference to FIG. 18, a response timing control system, in accordance with an embodiment, is shown. The response timing control system includes a response timing control **138**. The response timing control **138** is communicably connected to the neural stimulation system **108** and a simultaneous event monitor **140**. The response timing control **138** receives timing instructions from the event monitor **140** and provides timing instructions to the neural stimulation system **108**, so that the stimulation and training occur simultaneously. Because the stimulation is generated in response to an event, the stimulation will generally lag the event by some finite time delta t . In cases where there is an event precursor that can be monitored, the timing can be made more exact.

[0060] With reference to FIG. 19, a graph shows a possible timing relationship between a monitored event and a nerve stimulation.

[0061] With reference to FIG. 20, a manual timing control system, in accordance with an embodiment, is shown. The manual timing control system includes a response timing control **138**. The response timing control **138** is communicably connected to the neural stimulation system **108** and a manual input **142**. The response timing control **138** receives timing instructions from the manual input **142** and provides timing instructions to the neural stimulation system **108**, so that the stimulation and training occur simultaneously.

[0062] With reference to FIG. 21, a graph shows a possible timing relationship between an event, a manual input and a neural stimulation.

[0063] With reference to FIG. 22, a closed loop timing control system, in accordance with an embodiment, is shown. The closed loop timing control system includes a closed loop timing control **144**. The closed loop timing control **138** is communicably connected to the neural stimulation system **108** and a sensor **146**. The closed loop timing control **144** receives timing instructions from the sensor **146** and provides timing instructions to the neural stimulation system **108**, so that the stimulation and training occur simultaneously.

[0064] With reference to FIG. 23, a graph shows a possible timing relationship between an sensed training event and a neural stimulation is shown.

[0065] Sensor **146** may monitor external or internal events, including heart-rate, blood pressure, temperature, chemical levels or any other parameter that may indicate a training event.

[0066] With reference to FIG. 24, a initiated timing control system, in accordance with an embodiment, is shown. The initiated timing control system includes an initiated timing control **148**. The initiated timing control **148** is communicably connected to a neural stimulation system **106** and an event generator **150**. The initiated timing control **148** receives timing information from the neural stimulation system **106**, indicating that a nerve has been stimulated. The initiated timing control **148** provides timing instructions to the event generator **150**, such as a therapeutic sound generator connected by Bluetooth, such that the event generator **150** generates an event during the stimulation pulse.

[0067] With reference to FIG. 25, a graph shows a possible timing relationship between a neural stimulation and an event generation.

[0068] With reference to FIG. 26, a delayed response timing control system, in accordance with an embodiment, is shown. The delayed response timing control system includes a delayed response timing control **152**. The delayed response timing control **152** is communicably connected to a

neural stimulation system **106** and a preliminary event sensor **154**. The preliminary event sensor **154** detects a preliminary event that anticipates a pairing event. The delayed response timing control **148** receives timing information from the preliminary event sensor **154**, indicating that a preliminary event has been detected. The delay response timing control **148** provides timing instructions to the neural stimulation system **106** to initiate nerve stimulation. In the depicted embodiment, the timing control **152** initiates the stimulation before the beginning of the pairing event, giving a negative delta t. A delay response timing system may initiate stimulation at the same time as the beginning of the pairing event, or after the beginning of the pairing event.

[0069] With reference to FIG. 27, a graph shows a possible timing relationship between a neural stimulation, a preliminary event and a pairing event.

[0070] Human and animal studies have shown that neurons deprived of auditory input begin to respond to frequencies adjacent to the region of cochlear damage. This plasticity results in a dramatic increase in the number of neurons that respond to the frequencies that border the region of hearing loss. After noise trauma, spontaneous activity in those neurons becomes highly synchronized due to abnormally high input overlaps. This synchronous activity is likely responsible for the subjective tinnitus experience. The severity of tinnitus is highly correlated ($r=0.82$) with cortical map reorganization caused by hearing loss. In this way, tinnitus is similar to the phantom limb pain after amputation as well as chronic pain syndromes after peripheral nerve damage. The severity of phantom limb pain in amputees is also strongly correlated ($r=0.87$) with the extent of map reorganization and synchronized spontaneous activity is believed to give rise to ongoing pain. Targeted neural plasticity provides a clear opportunity to restore normal operation to dysfunctional circuits.

[0071] VNS may be paired with tones to treat tinnitus. VNS may be paired with touch to treat chronic pain. VNS may be paired with skilled movement to treat motor impairments. VNS may be paired with cognitive therapy to treat cognitive impairments. VNS may be paired with desensitization therapy to treat PTSD or anxiety. VNS may be paired with speech therapy to treat communication disorders.

[0072] FIG. 28 depicts a tinnitus therapy, in accordance with an embodiment. A patient has a VNS system implanted so that the vagus nerve electrode contacts a portion of a vagus nerve. The vagus nerve electrode is connected by a flexible wire lead to a pulse generator. A VNS tinnitus therapy may include a 2.5-hour tinnitus therapy during a single day. During the 2.5 hour tinnitus therapy, a 50 dB tone and paired stimulation train is presented every thirty seconds, effectively presenting the pairs 300 times. Each 50 dB tone and stimulation train lasts for about 0.5 seconds. The stimulation train may be a series of 0.8 mA, 30 Hz stimulation pulses.

[0073] FIG. 29 depicts a schematic illustration of the tinnitus pathology and treatment. Cochlear damage at high frequencies results in map reorganization in the auditory cortex, which gives rise to the tinnitus sensation. Pairing VNS with adjacent low tones, the non-tinnitus frequencies, restores the distorted map. As shown in FIG. 29, under normal conditions each neuron in the auditory cortex is tuned to a small range of tone frequencies (vertical lines) represented on the y-axis. Each line type represents the tone range to which the corresponding part of the auditory cortex responds. This tonotopic mapping of the auditory cortex is shown along the x-axis. The frequency preferences of auditory cortex neurons are ordered

to form a topographic map from low to high in the posterior to anterior direction (FIG. 29, left). As shown in the center panel of FIG. 29, when cochlear damage was induced that removed the part of the cochlea that send signals of high frequencies to the auditory cortex, the anterior regions of the auditory cortex began to respond to the middle frequencies from the cochlea. This pathological reorganization of the auditory cortex in response to damage is accompanied by an increase in synchronous activity in the primary auditory cortex. VNS is paired with low frequency tones to reorganize the auditory cortex as shown in the far right panel of FIG. 29. Note that neurons still do not respond to high frequencies, as those inputs have been destroyed. However, the tonotopic map of the auditory cortex has now been redistributed so that no part of the cortex exhibits the type of pathological plasticity that leads to increased synchronous activity.

[0074] The plasticity induced by neural stimulation can be paired with a variety of therapies, rehabilitation, training and other forms of personal improvement. Each therapy acts as a training source. The specific timing requirements associated with each therapy are derived from the specifics of the therapy, such that the stimulation occurs during the training, and most effectively near the beginning of the training. Some possible therapies may include behavioral therapies such as sensory discrimination for sensory deficits, motor training for motor deficits, with or without robotic assistance and cognitive training/rehabilitation for cognitive deficits. Exercise and motor therapy could be paired to treat motor deficits arising from traumatic brain injury, stroke or Alzheimer's disease and movement disorders. Constraint induced therapy could be paired to help prevent the use of alternative strategies in order to force use of impaired methods. Speech therapy could be paired for speech and language deficits. Cognitive therapies could be paired for cognitive problems.

[0075] Sensory therapies, such as tones, could be paired to treat sensory ailments such as tinnitus. In treating tinnitus, the paired tones may be at frequencies distinct from the frequencies perceived by the tinnitus patient.

[0076] Exposure or extinction therapy could be paired to treat phobias or post-traumatic stress disorder.

[0077] Computer-based therapies such as FastForward for dyslexia, Brain Fitness Program Classic or Insight, could be paired to enhance their effects. Psychotherapy could be paired, as well as other therapeutic activities in the treatment of obsessive-compulsive disorder, depression or addiction.

[0078] Biofeedback therapy could be paired. For example, temperature readings or galvanic skin responses could be paired to treat anxiety or diabetes. An electromyograph could be paired to improve motor control after brain spinal or nerve damage. A pneumograph could be paired to improve breathing control in a paralyzed patient. A real-time fMRI could be paired to improve pain control or treat OCD. An electrodermograph, EEG, EMG or electrocardiograph could be paired to treat disorders such as anxiety. An electroencephalograph could be paired to treat epilepsy. A hemoencephalography could be paired to treat migraines. A photoplethysmograph could be paired to treat anxiety. A capnometer could be paired to treat anxiety. Virtual reality therapy could be paired to treat disorders such as addiction, depression, anxiety or posttraumatic stress disorder. Virtual reality therapy could also be paired to enhance cognitive rehabilitation or performance. Drug therapies could be paired to treat a variety of conditions. Amphetamine-like compounds could be paired to enhance neuromodulators and plasticity. SSRI's could be paired to

enhance neuromodulators and plasticity. MOA inhibitors could be paired to enhance neuromodulators and plasticity. Anti-coagulants could be paired to act as clot busters during acute stroke. Various drugs could be paired to stop spasm after nerve or brain damage such as Botulinum toxin, Lidocaine, etc. Small doses of drugs of abuse could be paired to extinguish cravings in addicts.

[0079] Hormone therapy could be paired. For example, progesterone, estrogen, stress, growth, or thyroid hormone, etc. could be paired to treat traumatic brain injury or Alzheimer’s disease. Glucose therapy could be paired to treat anxiety. Electrical or magnetic stimulation of the central or peripheral nervous system could be paired. For example, transcranial magnetic stimulation could be used to enhance or reduce activity in a specific brain area and thereby focus the directed cortical plasticity. Transcutaneous electrical nerve stimulation could be paired to treat chronic pain, tinnitus and other disorders. Subcutaneous electrical nerve stimulation could be paired to treat chronic pain. Stem cell therapy could be paired to treat disorders such as Parkinson’s disease. Gene therapy could be paired to treat conditions such as Down’s syndrome, Huntington’s disease or fragile X syndrome. Hyperbaric oxygen therapy could be paired to treat carbon monoxide poisoning

[0080] Multiple therapies could be paired simultaneously or sequentially.

[0081] None of the description in the present application should be read as implying that any particular element, step, or function is an essential element which must be included in the claim scope: THE SCOPE OF PATENTED SUBJECT MATTER IS DEFINED ONLY BY THE ALLOWED CLAIMS. Moreover, none of these claims are intended to invoke paragraph six of 35 USC section 112 unless the exact words “means for” are followed by a participle.

[0082] The claims as filed are intended to be as comprehensive as possible, and NO subject matter is intentionally relinquished, dedicated, or abandoned.

What is claimed:

- 1. A tinnitus treatment system comprising:
 - a neurostimulator configured to provide stimulation to a nerve during a stimulation period;
 - an audible sound generator configured to provide an audible sound including a therapeutic frequency during a sound period; and
 - a timing control communicably connected to said neurostimulator and said audible sound generator wherein said timing control is configured to cause said stimulation period and said sound period to be temporally linked.
- 2. The system of claim 1, wherein said stimulation period begins before said sound period.
- 3. The system of claim 1, wherein said stimulation is an electrical stimulation.
- 4. The system of claim 1, wherein said audible sound is a tone.
- 5. The system of claim 1, wherein said audible sound comprises a sweep of therapeutic frequencies.
- 6. The system of claim 1, wherein said nerve is a cranial nerve.
- 7. The system of claim 6, wherein said cranial nerve is a vagus nerve.

8. The system of claim 1, wherein said timing control is configured to cause said stimulation period and said sound period to be simultaneous.

9. A method of treating tinnitus in a patient, comprising:

- determining a therapeutic frequency for the patient symptoms;
- generating an audible sound including a therapeutic frequency during a sound period;
- stimulating a nerve during a stimulation period; and
- controlling said nerve stimulation such that a temporal location of said stimulation period is based on a temporal location of said sound period.

10. The method of claim 9, wherein said stimulation period begins before the beginning of said sound period.

11. The method of claim 9, further comprising determining a plurality of therapeutic frequencies.

12. The method of claim 9, wherein said audible sound is a tone.

13. The method of claim 11, wherein said audible sound comprises a plurality of audible sounds at therapeutic frequencies.

14. The method of claim 9, further comprising repeating said generating and stimulating at predetermined intervals over a series of days.

15. The method of claim 14, wherein said series of days is two weeks.

16. The method of claim 9, wherein the action of controlling said nerve stimulation entails controlling said nerve stimulation such that said stimulation period and said sound period overlap.

17. A timing control system for a treatment, comprising:

- an audible sound timing connection;
- a neurostimulator timing connection; and
- a timing control communicably connected to said audible sound timing connection and to said neurostimulator timing connection, wherein said timing control is configured to provide timing instructions to an audible sound generator and to a neurostimulator system.

18. The timing control system of claim 17, wherein said timing instructions initiate simultaneous sound generation and neural stimulation.

19. The timing control system of claim 18, wherein said neural stimulation begins before the beginning of said sound generation.

20. The timing control system of claim 17, wherein said timing control is a computer process.

21. The timing control system of claim 17, wherein said timing control is an integrated circuit.

22. The timing control system of claim 18, wherein said timing control is configured to communicate with said neurostimulator via coupled coils.

23. The timing control system of claim 17, wherein:

- the neurostimulator system includes:
 - a neurostimulator; and
 - a neural stimulator control configured to receive timing instructions from the timing control and to initiate stimulation poses from the neurostimulator.

24. The timing control system of claim 17, wherein:

- the timing control is a synchronized timing control system and is configured to synchronize stimulation from the neurostimulator system with a sound generated by the audible sound generator.

* * * * *