



- (51) International Patent Classification:
H01T 13/32 (2006.01) *H01T 21/02* (2006.01)
- (21) International Application Number:
PCT/US2012/033497
- (22) International Filing Date:
13 April 2012 (13.04.2012)
- (25) Filing Language: English
- (26) Publication Language: English
- (30) Priority Data:
61/490,219 26 May 2011 (26.05.2011) US
- (71) Applicant (for all designated States except US): **FRAM Group IP, LLC** [US/US]; UCI/FRAM Group, 1900 West Field Court, Lake Forest, Illinois 60045 (US).
- (72) Inventors; and
- (75) Inventors/Applicants (for US only): **UNGER, Peter, D.** [US/US]; 36 Terry Drive, Morristown, New Jersey 07960 (US). **ROHRBACH, Ronald, P.** [US/US]; 430 Cherryville Road, Flemington, New Jersey 08822 (US). **BOEHLER, Jeffrey, T.** [US/US]; 1148 Kieswetter Road, Holland,

Ohio 43528 (US). **ZHENG, Jing** [US/US]; 742 Parkview Drive, Findlay, Ohio 45840 (US).

(74) Agent: **FOX, Erin, J.**; Barnes & Thornburg LLP, P.O. Box 2786, Chicago, IL 60690-2786 (US).

(81) Designated States (unless otherwise indicated, for every kind of national protection available): AE, AG, AL, AM, AO, AT, AU, AZ, BA, BB, BG, BH, BR, BW, BY, BZ, CA, CH, CL, CN, CO, CR, CU, CZ, DE, DK, DM, DO, DZ, EC, EE, EG, ES, FI, GB, GD, GE, GH, GM, GT, HN, HR, HU, ID, IL, IN, IS, JP, KE, KG, KM, KN, KP, KR, KZ, LA, LC, LK, LR, LS, LT, LU, LY, MA, MD, ME, MG, MK, MN, MW, MX, MY, MZ, NA, NG, NI, NO, NZ, OM, PE, PG, PH, PL, PT, QA, RO, RS, RU, RW, SC, SD, SE, SG, SK, SL, SM, ST, SV, SY, TH, TJ, TM, TN, TR, TT, TZ, UA, UG, US, UZ, VC, VN, ZA, ZM, ZW.

(84) Designated States (unless otherwise indicated, for every kind of regional protection available): ARIPO (BW, GH, GM, KE, LR, LS, MW, MZ, NA, RW, SD, SL, SZ, TZ, UG, ZM, ZW), Eurasian (AM, AZ, BY, KG, KZ, MD, RU, TJ, TM), European (AL, AT, BE, BG, CH, CY, CZ, DE, DK, EE, ES, FI, FR, GB, GR, HR, HU, IE, IS, IT, LT, LU,

[Continued on next page]

(54) Title: ANTI-FOULING SPARK PLUG AND METHOD OF MAKING

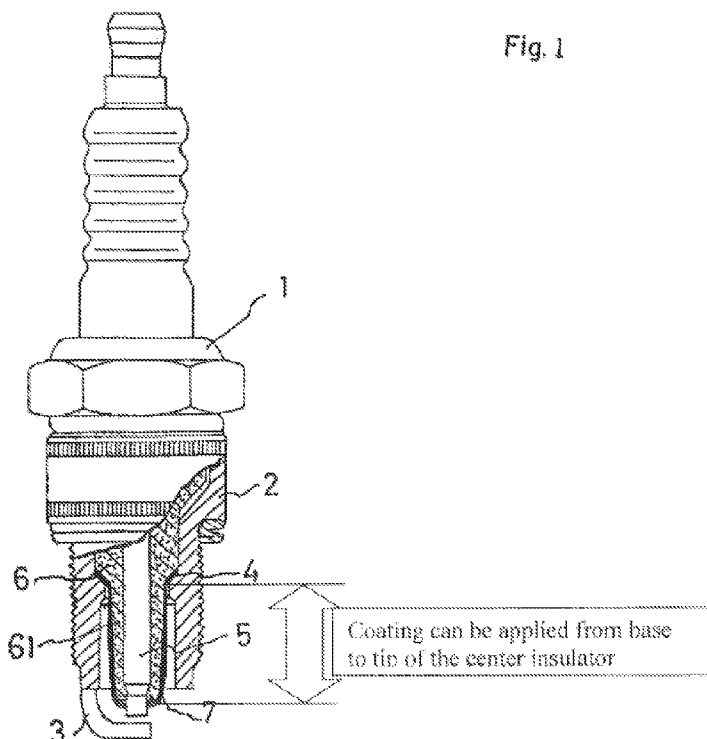

(57) Abstract: A spark plug is provided. The spark plug has an insulative sleeve with a central axial bore and an exterior surface of a shaped tip portion. A coating is disposed on the exterior surface of the shaped tip portion and the coating comprises a transition metal compound or a combination of transition metal compounds, and an alkali metal compound. A center electrode extends through the central axial bore of the insulative sleeve. A metal sleeve is provided, wherein the insulating sleeve is positioned within, and secured to, the metal shell. A ground electrode is coupled to the metal shell and positioned in a spaced relationship relative to the center electrode so as to define a spark gap.

WO 2012/161886 A1

LV, MC, MK, MT, NL, NO, PL, PT, RO, RS, SE, SI, SK, SM, TR), OAPI (BF, BJ, CF, CG, CI, CM, GA, GN, GQ, GW, ML, MR, NE, SN, TD, TG).

Published:

Declarations under Rule 4.17:

- *as to applicant's entitlement to apply for and be granted a patent (Rule 4.17(ii))*
- *as to the applicant's entitlement to claim the priority of the earlier application (Rule 4.17(iii))*

- *with international search report (Art. 21(3))*
- *before the expiration of the time limit for amending the claims and to be republished in the event of receipt of amendments (Rule 48.2(h))*

ANTI-FOULING SPARK PLUG AND METHOD OF MAKING

CROSS REFERENCE TO RELATED APPLICATIONS

[0001] This application claims the benefit of United States Provisional Application Serial Number 61/490,219 filed on May 26, 2011 the contents of which are incorporated herein in their entirety.

BACKGROUND

[0002] In general, spark plugs include an insulative sleeve having a central axial bore through which a center electrode extends. The insulating sleeve is positioned within, and secured to, a metal shell that serves as a mounting platform and interface to an internal combustion engine. The metal sleeve also supports a ground electrode that is positioned in a particular spaced relationship relative to the center electrode so as to generate a spark gap. The insulating sleeve includes a shaped tip portion that resides in a recessed end portion of the metal shell. The shaped tip portion is configured to protect the electrode from engine heat and products of combustion. The spark plug is typically mounted to an engine cylinder head and selectively activated to ignite a fuel/air mixture in an associated engine cylinder.

[0003] Over time, products of combustion or combustion deposits build up around the center electrode and insulative sleeve, particularly the shaped tip portion. This build up of combustion product inhibits spark formation across the spark gap. A significant build up of combustion products may foul the spark plug and result in ignition failure, i.e., the combustion products completely block the spark from forming between the center and ground electrodes due to an electrical short circuit formed from the combustion products. Combustion deposit build up is particularly problematic during cold starts. During cold starts, complete combustion of the air/fuel mixture is seldom achieved which results in an increased generation of electrically conductive combustion deposits. As a result of continuous cold starts, electrically conductive combustion deposits build up, resulting in an electrical short circuit between the center electrode and the electrically grounded portion of the spark plug.

[0004] Previous, attempts to address combustion deposit build up issues have included silicone oil coatings and particulate vanadium oxide deposition on the insulating sleeve. These coatings have failed to adequately address the issue – suffering from inadequate performance at elevated temperature, inadequate endurance, or insufficient reduction of combustion deposit build up.

[0005] Accordingly, there is a need for a spark plug which has a decreased susceptibility to electrically conductive combustion deposit build up in the insulative sleeve.

BRIEF DESCRIPTION

[0006] In accordance with one embodiment of the invention, a spark plug is provided. The spark plug has an insulative sleeve with a central axial bore and an exterior surface of a shaped tip portion. A coating is disposed on the exterior surface of the shaped tip portion and the coating comprises a transition metal compound or a combination of transition metal compounds, and an alkali metal compound. A center electrode extends through the central axial bore of the insulative sleeve. A metal sleeve is provided, wherein the insulating sleeve is positioned within, and secured to, the metal shell. A ground electrode is coupled to the metal shell and positioned in a spaced relationship relative to the center electrode so as to define a spark gap.

[0007] In accordance with another embodiment of the invention, a method of coating a spark plug insulator is provided. The method includes the step of forming a first slurry solution including one or more transitional metal compounds, the one or more transitional metals comprising up to 70 weight percent of the total weight of the slurry solution. The first slurry solution is applied to an insulative sleeve. A first coating is formed by air drying the first slurry solution on the insulative sleeve for a first predetermined time at a first predetermined temperature. The first coating is calcined at a third predetermined temperature for a third predetermined amount of time.

[0008] In accordance with still another embodiment of the invention, another method of coating a spark plug insulator is provided. The method includes forming a first slurry solution including from a alkali metal compound, the alkali metal compound being up to 70 weight percent of the total weight of the slurry solution. The first slurry solution is applied to an insulative sleeve. A first coating is formed by air drying the first slurry solution on the insulative sleeve for a first predetermined time at a first predetermined temperature. The first coating is calcined at a third predetermined temperature for a third predetermined amount of time.

BRIEF DESCRIPTION OF THE DRAWING

[0009] Figure 1 is a side view of a spark plug, partly shown in cross section.

[0010] Figures 2-4 are graphical representations of data described in the examples.

DETAILED DESCRIPTION

[0011] The coating, as described herein, is a substantially continuous coating. A substantially continuous coating, as defined herein, describes a coating which is has no breaks or gaps visible to the naked eye and covers a portion of shaped tip portion the exterior surface of the insulative sleeve. The coating thickness can range from a molecular monolayer to several micrometers in thickness. In one embodiment, the monolayer may be 5 to 15 micrometers in thickness. In other embodiments the coating has a thickness of 1-10 micrometers.

[0012] Suitable transition metal compounds comprise one or more transition metals. Exemplary transition metals include chromium, molybdenum, tungsten, zirconium, iron, lead, vanadium, niobium, tantalum, copper, silver, gold, nickel, platinum, and palladium. Exemplary transition metal compounds include oxides and carbonates of the foregoing transition metals. For simplicity of handling it is desirable for the transition metal compound to be water soluble. Exemplary water soluble compounds include copper nitrate, copper chloride, ammonium heptamolybdate 4 hydrate, molybdenum chloride, potassium paramolybdate, and combinations of two or more of the foregoing compounds.

[0013] In some embodiments the coating may comprise a combination of an early transition metal compound and a late transition metal compound. Exemplary early transition metals include chromium, molybdenum, tungsten, vanadium, niobium, and tantalum. Exemplary late transition metals include copper, silver, gold, nickel, platinum, and palladium. An exemplary combination comprises a molybdenum compound and a copper compound.

[0014] The alkali metal compound may comprise lithium, sodium, potassium, cesium, or a combination of two or more of the foregoing alkali metals. For simplicity in handling it is desirable for the alkali metal compound to be water soluble. Exemplary water soluble alkali metal compounds include potassium chloride, potassium carbonate, potassium bicarbonate, potassium nitrate, potassium hydroxide, and combinations of two or more of the foregoing compounds.

[0015] The molar ratio of the transition metal compound to the alkali metal compound (transition metal/ alkali metal) can be 1:1 to 16:1. When the coating comprises late and early transition metal compounds the molar ratio of the late transition metal compound to early transition metal compound to alkali metal compound can be 1:0.5:1 to 1:7:1.

[0016] Surprisingly it has been found that the coatings described above are not sufficiently conductive, at the thicknesses described herein, to interfere with the operation of

the spark plug. Without being bound by theory it is speculated that the coating may function as a catalyst to facilitate combustion either during a cold start or during subsequent operation, thus reducing or removing the combustion deposit build up on the surface. Alternatively, the coating may absorb oxygen which it can then provide during combustion at the interface of the insulative sleeve and the combustion products, thus facilitating more complete combustion.

[0017] The coating is formed on the insulative sleeve by forming a slurry or solution comprising the transition metal compound or combination of transition metal compounds. The solution can further comprise the alkali metal compound. The slurry or solution is applied to the insulative sleeve by any appropriate method such as painting, dip coating, spray coating and the like. In some embodiments the slurry is an aqueous slurry. In some embodiments the solution is an aqueous solution. The slurry or solution can comprise up to 70 weight percent of the transition metal compound or combination of transition metal compounds, based on the total weight of the slurry or solution. Within this range the amount of transition metal compound(s) in the slurry or solution can be 0.1 to 10 weight percent, or, more specifically, 0.1 to 5 weight percent. Slurries can be used at higher weight percents than solutions. Solutions, if made too concentrated can have solubility issues. The slurry or solution can comprise up to 70 weight percent of the alkali metal compound, based on the total weight of the slurry or solution. Within this range the amount of alkali metal compound in the slurry or solution can be 0 to 10 weight percent, or more specifically 0.25 to 7.5 weight percent. In another embodiment, the alkali metal compound in the slurry or solution can be 0.5 to 5 weight percent.

[0018] The applied slurry or solution is allowed to air dry at room temperature to form a coated insulative sleeve. The coated insulative sleeve can then be treated at an elevated temperature, such as 70 to 150 degrees C for 30 minutes to 60 hours. The coated insulative sleeve is then calcined at a temperature of 475 to 950 degrees C for a period of 30 minutes to several hours. Within this range the calcination time can be 30 minutes to 1.5 hours. After calcining alkali metal solution or slurry can be applied and drying and calcining repeated to form a coating with alkali metal compound primarily at the surface.

[0019] The alkali metal can also be applied separately in a two-stage process. In this scenario, a first coating comprising a mixture of transition metals may be applied and calcined as described above. The sleeve thus coated may be then further subjected to a second coating of an alkali metal solution, and then finally calcined as described above. The first coating might comprise either of the transition metals only or a mixture containing alkali

metal. The two-stage process can effectively result in surface enrichment of the final coating with alkali metal.

[0020] An exemplary spark plug is shown in Figure 1. The spark plug, **1**, has a metal shell, **2**, a ground electrode, **3**, a center electrode, **5**, an insulative sleeve, **6**, a shaped tip portion of the insulative sleeve, **61**, and a coating, **7**, disposed on the insulative sleeve. The longitudinal extent of the coating (from center electrode to metal shell) can vary. Importantly, the coating should form a continuous coating around the circumference of the insulative sleeve in at least one location.

[0021] The invention is further illustrated by the following non-limiting examples.

[0022] Several coatings were screened for conductivity and impact on combustion deposit accumulation/removal using the following procedure. An aqueous solution of the metal compounds was coated onto half of an alumina slide, leaving one side uncoated to function as a control. After coating the slide was air dried and calcined at 475-975 degrees C for 60 minutes. Calcination temperatures were approximately 625-650 degrees C for the Cu/Mo/K mixes and higher for CuO and V₂O₅. Resistivity (electrical resistance) was measured using a Fluke 1507 Megohmmeter. Higher resistance means less conductivity. The candidates were then further evaluated for soot burn off (conductive deposit removal). The entire strip was coated with soot (combustion products) and placed within a vycor tube in a tube furnace and a cole-parmer digital temperature controller was used to adjust the temperature from ambient temperature to about 625°C at a heating rate of 8.5°C/minute. Observations were made on achieving 200, 300, 400, 450, 475, 500, 525, 550, 575, 600 and 625 °C. Soot loss was visually estimated and recorded. Results are shown in Figures 2, 3 and 4.

[0023] Figure 2 shows soot degradation curves for the individual components as well as vanadium pentoxide (as a comparison). Each individual component shows an improvement over the control but only moderately good results compared to vanadium pentoxide.

[0024] Figure 3 shows soot degradation curves for the individual components, vanadium pentoxide (as a comparison), two component mixtures containing a copper compound, and the tri component mixture containing a copper compound, a molybdenum compound and a potassium compound. The tri component mixture started clearing soot at a lower temperature than vanadium pentoxide and cleared the soot faster with complete removal of the soot at a lower temperature than the vanadium pentoxide.

[0025] Figure 4 shows soot degradation curves for molybdenum and potassium as individual components, vanadium pentoxide (as a comparison), two component mixtures containing a molybdenum compound, and the tri component mixture containing a copper compound, a molybdenum compound and a potassium compound. The tri component mixture demonstrates the best performance with the molybdenum/potassium combination also demonstrating good performance.

[0026] While the invention has been described with reference to a preferred embodiment, it will be understood by those skilled in the art that various changes may be made and equivalents may be substituted for elements thereof without departing from the scope of the invention. In addition, many modifications may be made to adapt a particular situation or material to the teachings of the invention without departing from the essential scope thereof. Therefore, it is intended that the invention not be limited to the particular embodiment disclosed as the best mode contemplated for carrying out this invention, but that the invention will include all embodiments falling within the scope of the appended claims.

[0027] All ranges disclosed herein are inclusive of the endpoints, and the endpoints are combinable with each other.

[0028] All cited patents, patent applications, and other references are incorporated herein by reference in their entirety.

[0029] The use of the terms "a" and "an" and "the" and similar referents in the context of describing the invention (especially in the context of the following claims) are to be construed to cover both the singular and the plural, unless otherwise indicated herein or clearly contradicted by context. Further, it should further be noted that the terms "first," "second," and the like herein do not denote any order, quantity, or importance, but rather are used to distinguish one element from another.

CLAIMS

1. A spark plug comprising
an insulative sleeve having a central axial bore and an exterior surface of a shaped tip portion, wherein a coating is disposed on the exterior surface of the shaped tip portion and the coating comprises a transition metal compound or a combination of transition metal compounds, and an alkali metal compound;
a center electrode extending through the central axial bore of the insulative sleeve;
a metal sleeve, wherein the insulating sleeve is positioned within, and secured to, the metal shell; and
a ground electrode coupled to the metal shell and positioned in a spaced relationship relative to the center electrode so as to define a spark gap.
2. The spark plug of claim 1, wherein the coating has a thickness of a monomolecular layer to 20 micrometers.
3. The spark plug of claim 1, wherein the transition metal compound comprises a transition metal selected from the group consisting of chromium, iron, zirconium, lead, molybdenum, tungsten, vanadium, niobium, tantalum, copper, silver, gold, nickel, platinum, and palladium.
4. The spark plug of claim 1, wherein the transition metal compound is selected from the group consisting of copper nitrate, copper chloride, copper oxide, copper carbonate, ammonium heptamolybdate 4 hydrate, molybdenum chloride, potassium paramolybdate, and combinations of two or more of the foregoing compounds.
5. The spark plug of claim 1, wherein the transition metal compound comprises a water soluble compound of copper.
6. The spark plug of claim 1, wherein the transition metal compound comprises a water soluble compound of molybdenum.
7. The spark plug of claim 1, wherein the alkali metal compound is selected from the group consisting of lithium, sodium, potassium, cesium, and a combination of two or more of the foregoing alkali metals.
8. The spark plug of claim 1, wherein the molar ratio of the transition metal compound to the alkali metal compound is 1:1 to 16:1.
9. The spark plug of claim 1, wherein the coating comprises a molybdenum compound, a copper compound and a potassium compound.
10. A method comprising:

forming a first slurry solution including one or more transitional metal compounds, the one or more transitional metals comprising up to 70 weight percent of the total weight of the slurry solution;

applying the first slurry solution to an insulative sleeve;

forming a first coating by air drying the first slurry solution on the insulative sleeve for a first predetermined time at a first predetermined temperature; and,

calcining the first coating at a third predetermined temperature for a third predetermined amount of time.

11. The method of claim 10 further comprising:

forming a second slurry solution from a alkali metal compound, the alkali metal compound being up to 70 weight percent of the total weight of the slurry solution; and,

applying the second slurry solution to the calcined coating.

12. The method of claim 11 wherein the first predetermined temperature is between 70 to 150 degrees C and the first predetermined time is between 30 minutes to 60 hours.

13. The method of claim 10 wherein the third predetermined time is between 30 minutes and 1.5 hours and the third predetermined temperature is between 475 to 950 C.

14. The method of claim 10 further comprising:

applying the first slurry solution to the first calcined coating;

drying the first slurry solution on the first calcined coating to form a second coating; and,

calcining the second coating at a four predetermined temperature for a fourth predetermined amount of time.

15. The method of claim 10 wherein the first slurry solution is an aqueous slurry.

16. The method of claim 10 wherein the first slurry solution is an aqueous solution.

17. The method of claim 10 wherein the one or more transitional metals comprising 0.1 to 5 weight percent of the total weight of the slurry solution.

18. The method of claim 11 wherein the alkali metal compound comprises 0.25 to 7.5 weight percent of the total weight of the slurry solution.

19. A method comprising:

forming a first slurry solution including from a alkali metal compound, the alkali metal compound being up to 70 weight percent of the total weight of the slurry solution;

applying the first slurry solution to an insulative sleeve;

forming a first coating by air drying the first slurry solution on the insulative sleeve for a first predetermined time at a first predetermined temperature; and,
calcining the first coating at a third predetermined temperature for a third predetermined amount of time.

20. The method of claim 19 further comprising
applying the first slurry to the first coating;
forming a second coating by air drying the first slurry solution that was applied to the first coating; and,
calcining the second coating.

Fig. 1

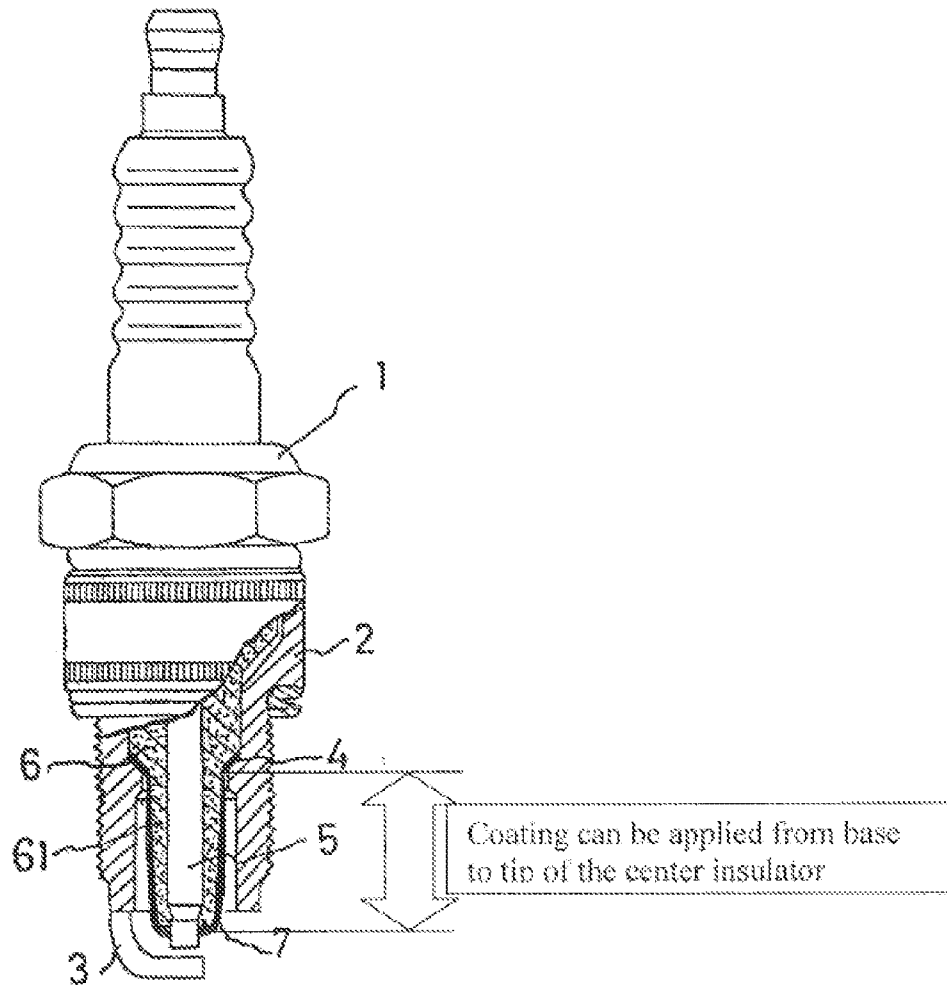

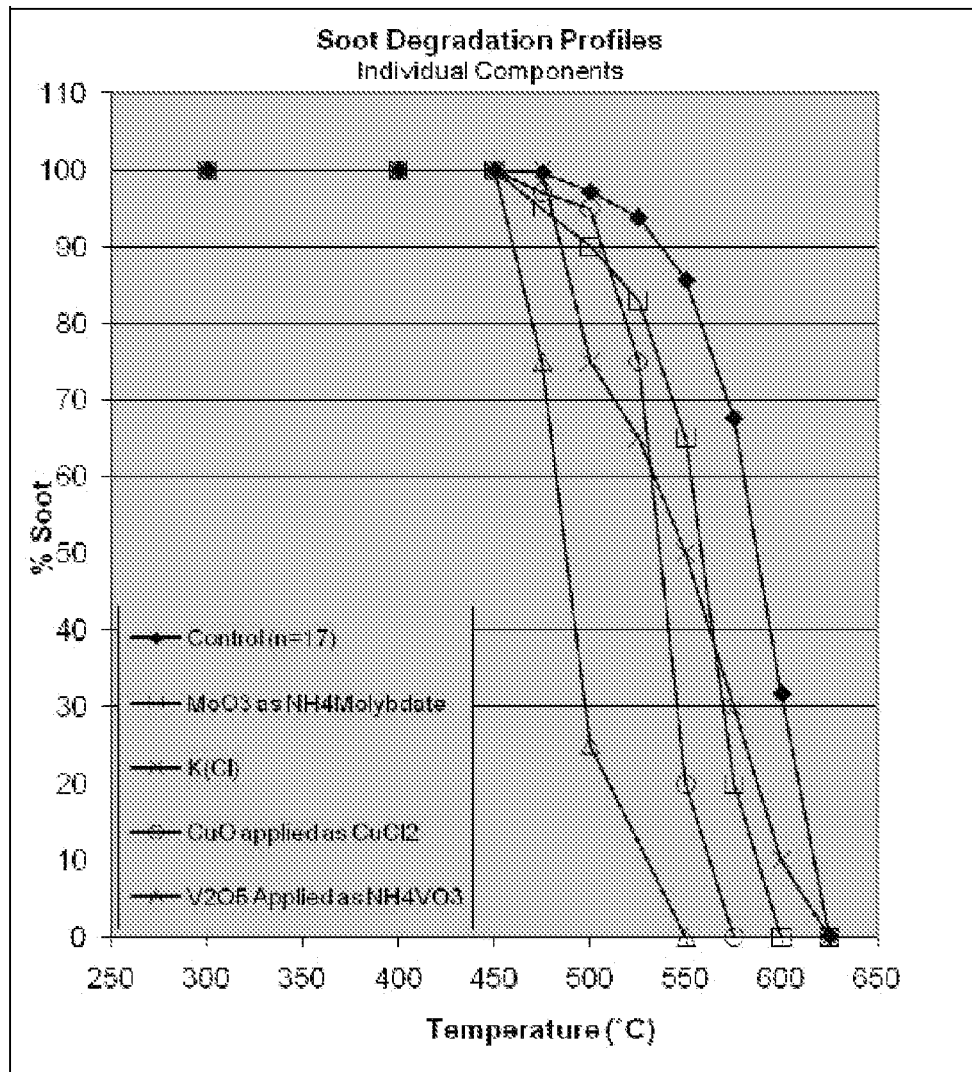

Fig. 2

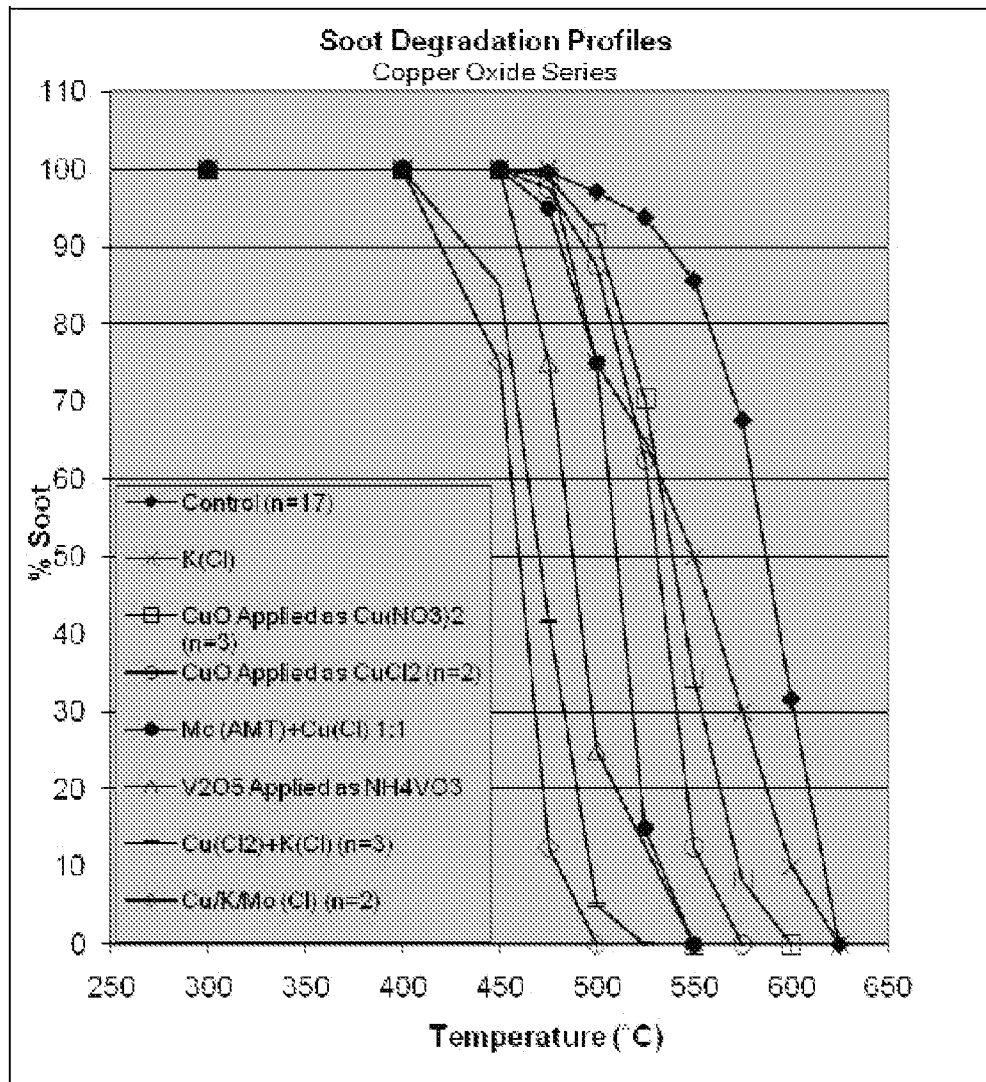

Fig. 3

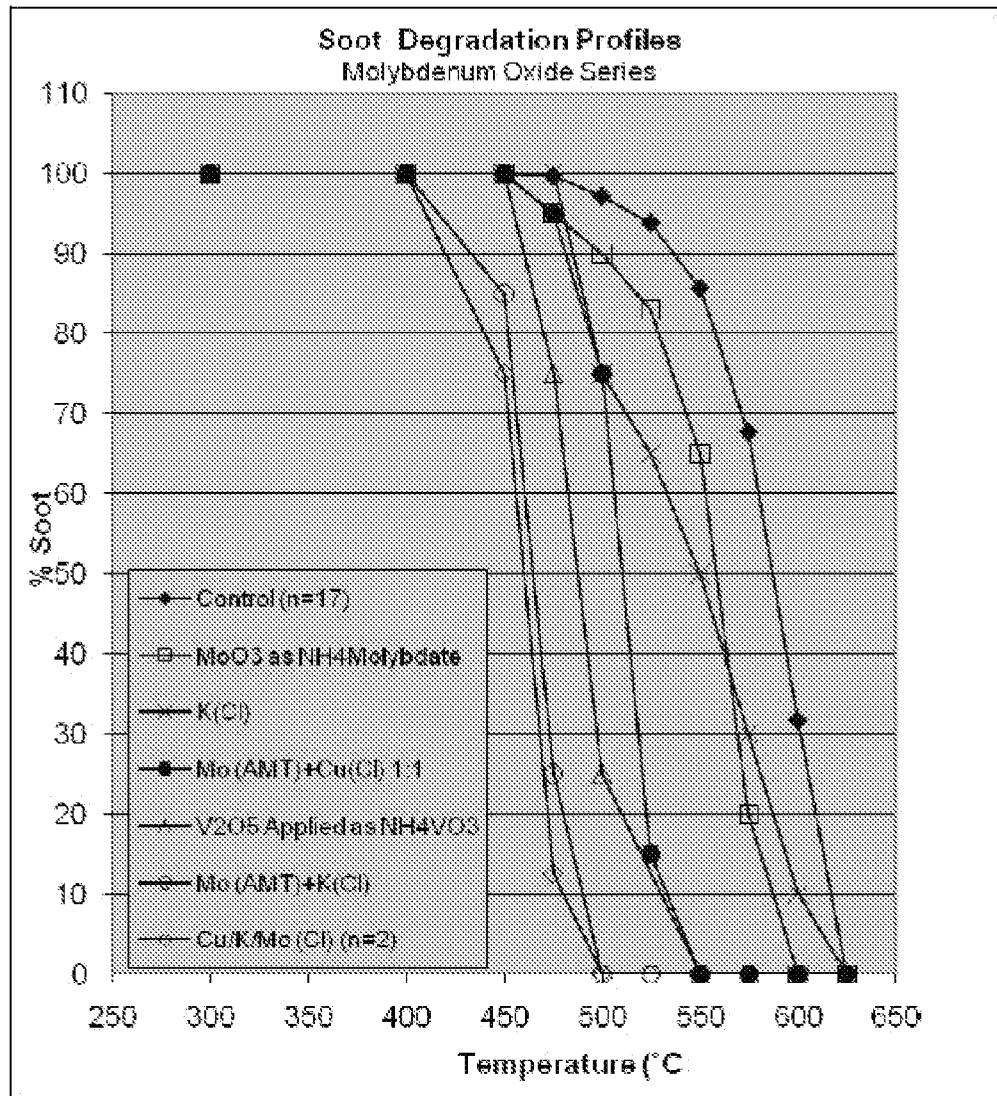

Fig. 4

A. CLASSIFICATION OF SUBJECT MATTER**H01T 13/32(2006.01)i, H01T 21/02(2006.01)i**

According to International Patent Classification (IPC) or to both national classification and IPC

B. FIELDS SEARCHED

Minimum documentation searched (classification system followed by classification symbols)

H01T 13/32; H01T 13/20; H01T 13/38; H01T 13/06; H01J 13/38

Documentation searched other than minimum documentation to the extent that such documents are included in the fields searched

Korean utility models and applications for utility models

Japanese utility models and applications for utility models

Electronic data base consulted during the international search (name of data base and, where practicable, search terms used)

eKOMPASS(KIPO internal) & Keywords: insulative sleeve, insulator, spark plug, central axis, bore,shaped tip portion, coating, center electrode, metal sleeve, metal shell, ground electrode, spark gap

C. DOCUMENTS CONSIDERED TO BE RELEVANT

| Category* | Citation of document, with indication, where appropriate, of the relevant passages | Relevant to claim No. |
|-----------|--|-----------------------|
| X | US 2002-0033659 A1 (KENICHI NISHIKAWA et al.) 21 March 2002 See paragraphs [0013]-[0018], [0120], [0151], [0245] and figures 1-5. | 1-20 |
| A | US 05109178 A (MITSUTAKA YOSHIDA et al.) 28 April 1992 See column 2, line 66 - column 3, line 39; claims 1-5 and figures 1-4. | 1-20 |
| A | US 2006-0055297 A1 (TAIJI KOYAMA et al.) 16 March 2006 See abstract; paragraphs [0042]-[0046]; claim 1 and figures 2-4. | 1-20 |
| A | US 05550424 A (IRENE JENNRICH et al.) 27 August 1996 See column 2, line 20 - column 3, line 4; claim 1 and figure 1. | 1-20 |

 Further documents are listed in the continuation of Box C. See patent family annex.

* Special categories of cited documents:

"A" document defining the general state of the art which is not considered to be of particular relevance

"E" earlier application or patent but published on or after the international filing date

"L" document which may throw doubts on priority claim(s) or which is cited to establish the publication date of citation or other special reason (as specified)

"O" document referring to an oral disclosure, use, exhibition or other means

"P" document published prior to the international filing date but later than the priority date claimed

"T" later document published after the international filing date or priority date and not in conflict with the application but cited to understand the principle or theory underlying the invention

"X" document of particular relevance; the claimed invention cannot be considered novel or cannot be considered to involve an inventive step when the document is taken alone

"Y" document of particular relevance; the claimed invention cannot be considered to involve an inventive step when the document is combined with one or more other such documents, such combination being obvious to a person skilled in the art

"&" document member of the same patent family

Date of the actual completion of the international search

30 OCTOBER 2012 (30.10.2012)

Date of mailing of the international search report

31 OCTOBER 2012 (31.10.2012)

Name and mailing address of the ISA/KR

Korean Intellectual Property Office
189 Cheongsu-ro, Seo-gu, Daejeon Metropolitan
City, 302-701, Republic of Korea

Facsimile No. 82-42-472-7140

Authorized officer

Park Jung Min

Telephone No. 82-42-481-5562



INTERNATIONAL SEARCH REPORT

Information on patent family members

International application No.

PCT/US2012/033497

| Patent document cited in search report | Publication date | Patent family member(s) | Publication date |
|--|------------------|-------------------------|------------------|
| US 2002-0033659 A1 | 21.03.2002 | CA 2339390 A1 | 29.08.2001 |
| | | CN 1317857 A0 | 17.10.2001 |
| | | CN 1326301 C0 | 11.07.2007 |
| | | DE 60107735 D1 | 20.01.2005 |
| | | DE 60107735 T2 | 08.12.2005 |
| | | DE 60132504 D1 | 06.03.2008 |
| | | DE 60132504 T2 | 15.01.2009 |
| | | DE 60132504 T8 | 16.04.2009 |
| | | DE 60138970 D1 | 23.07.2009 |
| | | DE 60140221 D1 | 26.11.2009 |
| | | EP 1130728 A2 | 05.09.2001 |
| | | EP 1130728 A3 | 02.07.2003 |
| | | EP 1130728 B1 | 15.12.2004 |
| | | EP 1434323 A2 | 30.06.2004 |
| | | EP 1434323 A3 | 13.04.2005 |
| | | EP 1434323 B1 | 16.01.2008 |
| | | EP 1434324 A2 | 30.06.2004 |
| | | EP 1434324 A3 | 13.04.2005 |
| | | EP 1434324 B1 | 10.06.2009 |
| | | EP 1434325 A2 | 30.06.2004 |
| | | EP 1434325 A3 | 13.04.2005 |
| | | EP 1434325 B1 | 14.10.2009 |
| | | JP 03-510172 B2 | 09.01.2004 |
| | | JP 03-632953 B2 | 30.03.2005 |
| | | JP 04-833526 B2 | 30.09.2011 |
| | | JP 2001-244043 A | 07.09.2001 |
| | | JP 2001-319755 A | 16.11.2001 |
| | | JP 2004-363112 A | 24.12.2004 |
| | | JP 3510172 B2 | 22.03.2004 |
| | | JP 4833526 B2 | 07.12.2011 |
| | | KR 20010085694 A | 07.09.2001 |
| | | US 6590318 B2 | 08.07.2003 |
| | | US 05109178 A | 28.04.1992 |
| EP 0390065 B1 | 19.01.1994 | | |
| JP 02-253588 A | 12.10.1990 | | |
| JP 06-050663 B2 | 29.06.1994 | | |
| JP 1918309 C | 07.04.1995 | | |
| JP 2253587 A | 12.10.1990 | | |
| US 2006-0055297 A1 | 16.03.2006 | DE 102005043637 A1 | 30.03.2006 |
| | | JP 2006-085941 A | 30.03.2006 |
| | | US 7250711 B2 | 31.07.2007 |
| US 05550424 A | 27.08.1996 | CN 1037046 C | 14.01.1998 |
| | | CN 1087758 A | 08.06.1994 |
| | | CN 1087758 C0 | 08.06.1994 |
| | | EP 0672312 A1 | 20.09.1995 |
| | | EP 0672312 B1 | 14.08.1996 |

INTERNATIONAL SEARCH REPORT

Information on patent family members

International application No.

PCT/US2012/033497

| Patent document cited in search report | Publication date | Patent family member(s) | Publication date |
|---|---------------------|----------------------------|---------------------|
| | | JP 08-503804 A | 23.04.1996 |
| | | KR 10-0276034 B1 | 15.12.2000 |
| | | WO 94-13046 A1 | 09.06.1994 |