

O. D. HERRICK.

Knuckle-Coupling for Tumbling-Shafts.

No. 165,231.

Patented July 6, 1875.

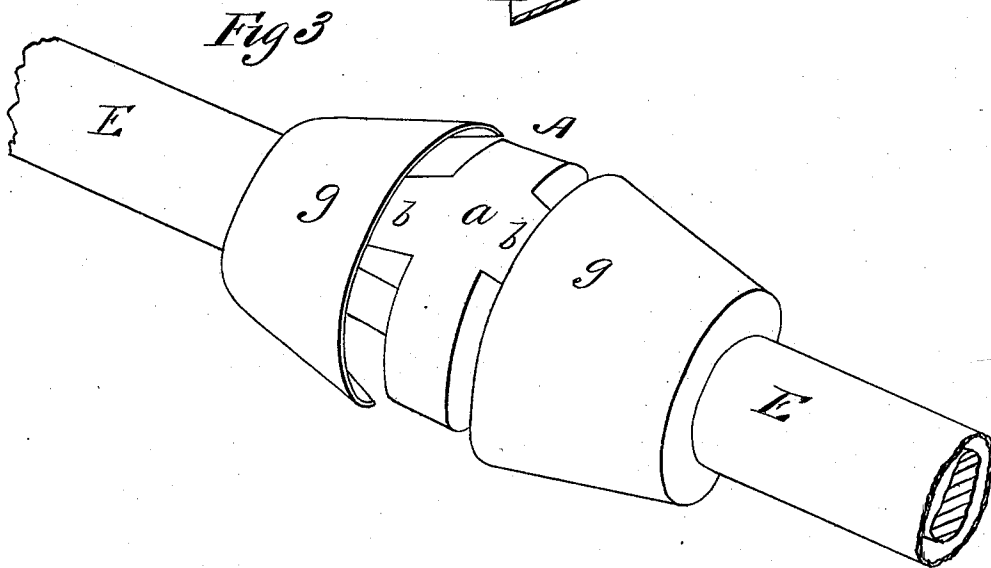
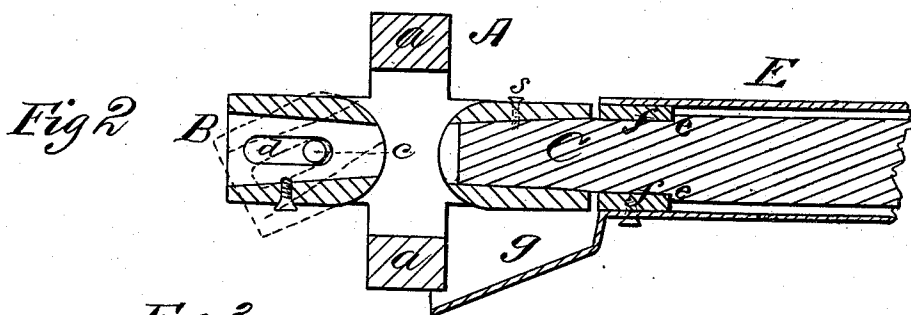
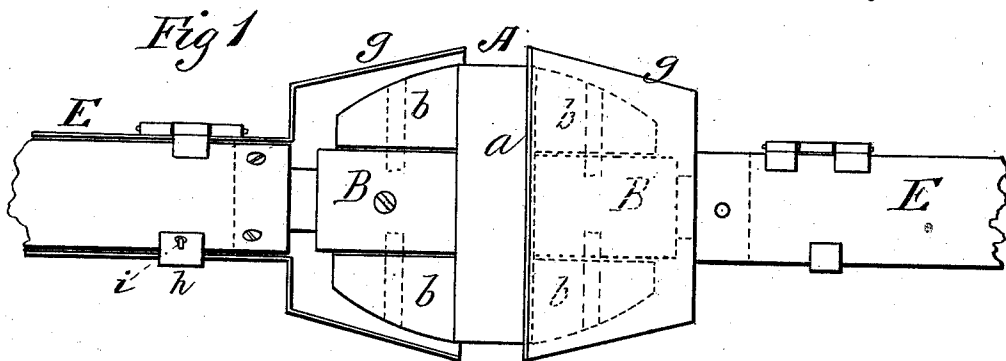

WITNESSES

*Eng. W. Johnson*  
*Francis J. Massi*

INVENTOR

*Oscar D. Herrick*  
*Chapman and Furrows*  
ATTORNEYS

O. D. HERRICK.

Knuckle-Coupling for Tumbling-Shafts.

No. 165,231.

Patented July 6, 1875.

*Fig 4*

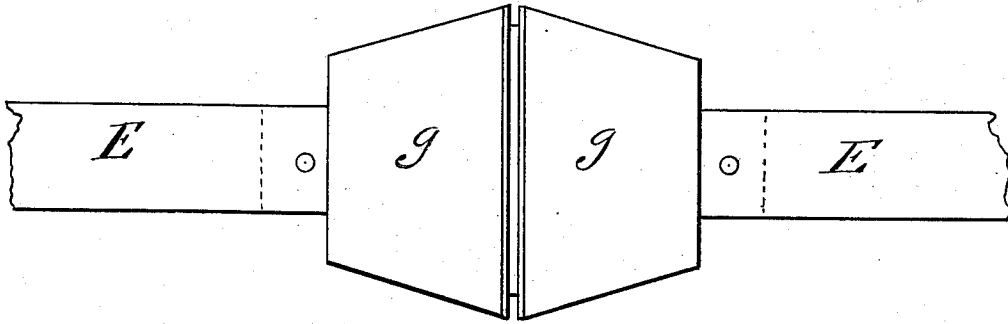

*Fig 5*

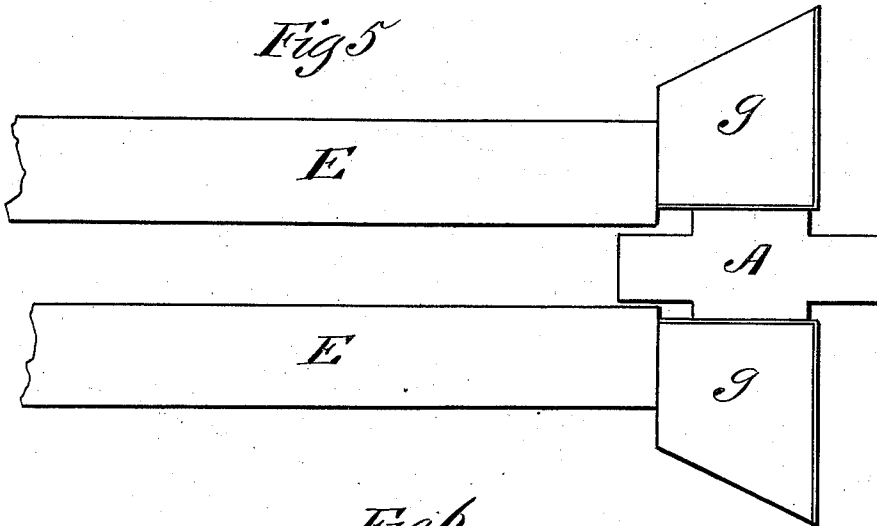

*Fig 6*

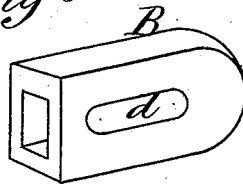

WITNESSES

*Engene W. Johnson*  
*George C. Wiskau.*

INVENTOR

*Oscar D. Herrick,*  
*Chipman & Sprunt & Co*  
ATTORNEYS

# UNITED STATES PATENT OFFICE.

OSCAR D. HERRICK, OF OTTUMWA, IOWA.

## IMPROVEMENT IN KNUCKLE-COUPPLINGS FOR TUMBLING-SHAFTS.

Specification forming part of Letters Patent No. **165,231**, dated July 6, 1875; application filed May 1, 1875.

*To all whom it may concern:*

Be it known that I, OSCAR D. HERRICK, of Ottumwa, in the county of Wapello and State of Iowa, have invented a new and valuable Improvement in Knuckle-Coupling for Tumbling-Shafts; and I do hereby declare that the following is a full, clear, and exact description of the construction and operation of the same, reference being had to the annexed drawings, making a part of this specification, and to the letters and figures of reference marked thereon.

Figure 1 of the drawings is a representation of a plan view of my device, and Fig. 2 is a longitudinal central sectional view of the same. Fig. 3 is a perspective view, and Figs. 4 and 5 are outside plan views. Fig. 6 is a detail view.

This invention has relation to improvements in tumbling rods or shafts, whereby motion is transferred from a horse-power to a separating or other machine.

The object of the invention is, first, to devise a joint for such rods which shall be of such a nature as to allow the rods to fold over upon each other, thus allowing them to be put in compact shape for transportation; and, secondly, to provide a cover, within which the said shaft will revolve, which will be capable of being folded over with the tumbling-shaft without being detached therefrom, as will be fully understood from, and claimed in, the following specification.

In the annexed drawings, A designates a coupling-box, consisting of a strong annulus or ring, *a*, and lugs *b*, projecting on each side thereof, between which are pivoted socket-blocks B, to which a slight endwise movement between the said lugs is allowed by passing the pivots *c* of the said blocks into slots *d* cut in their length, as shown in Fig. 2.

Blocks B are tubular, the shape of the tube being preferably quadrangular; and they constitute, with coupling-box A, a species of knuckle-joint, whereby axial rotation imparted to tumbling-rod C, socketed into one of the blocks B, will be communicated to a second rod, socketed in the other block, and the said rods will be allowed to fold inward upon each

other through the medium of the pivotal blocks B; and rods A being permanently but detachably secured into their sockets by means of a screw, *s*, the entire tumbling-shaft, which may be made up of any number of rods, is thus made capable of being folded-up into compact form for transportation.

By this means the loss of time and expense incurred in taking apart and joining together the various sections of tumbling-shaft are effectually obviated.

E represents a tubular metal sheathing, inclosing each section of tumbling-shaft, which sheathing is provided at each end with an interior annulus, *f*, upon which the said rod finds its bearings, and an enlargement or swell, *g*, in the form of one-half the frustum of a cone, within which the ends of the coupling-block are adapted to be received and rotate. Rods A are prevented from endwise displacement, relative to their sheathings, by means of shoulders *e* formed thereon, behind annulus *f*; and in order that the said rods may be placed therein, the said sheathings may be made sectional, the said sections being longitudinal, and hinged together, and then united by means of a catch, *h*, on one section, which is engaged over a pin, *i*, on the other.

The enlargements *g* being only applied over one-half the periphery of these sheathings, they will interpose no obstacle to the folding of the sections of tumbling-shaft, while at the same time they will cover every part of coupling box or joint of the said rods, as shown in Fig. 3, when the said shaft is in use, thereby effectually preventing their joint from catching the clothing of the operators.

To fold the shaft, contiguous sections are drawn outward from each other, and socket-blocks B having endwise movement in coupling A, coverings *g* will be separated, allowing the said blocks to vibrate freely in the couplings, and the sections to be folded the one upon the other, presenting the appearance shown in Fig. 2, when they may be tied up, and thus fitted for transportation.

What I claim as new, and desire to secure by Letters Patent, is—

1. The combination of the sectional sheath-

ing E with a sectional and folding tumbling-shaft, substantially as specified.

2. The sectional metallic sheathing E, having bearing-rings *f* and swells or enlargements *g* in the form of half a conical frustum, adapted for use in connection with a folding sectional tumbling-shaft, substantially as specified.

In testimony that I claim the above I have hereunto subscribed my name in the presence of two witnesses.

OSCAR D. HERRICK.

Witnesses:

WM. TORNLEY,  
WM. POWELL.