

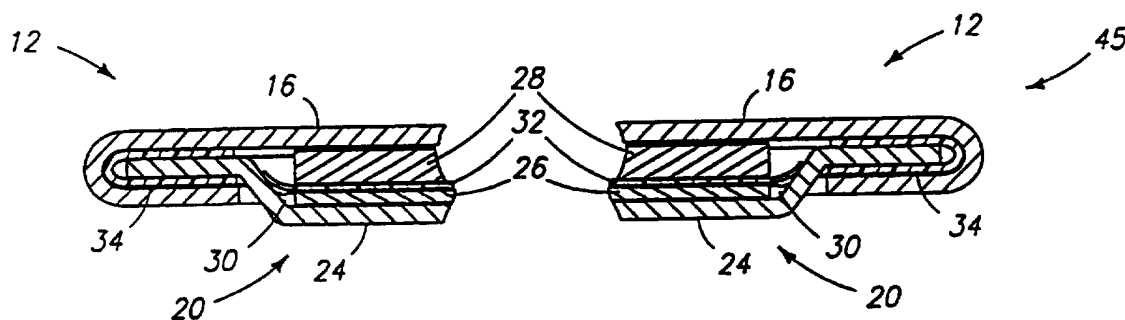

INTERNATIONAL APPLICATION PUBLISHED UNDER THE PATENT COOPERATION TREATY (PCT)

(51) International Patent Classification ⁶ : H01M 2/04, 2/02, 6/12	A1	(11) International Publication Number: WO 96/17390 (43) International Publication Date: 6 June 1996 (06.06.96)
<p>(21) International Application Number: PCT/US95/15192</p> <p>(22) International Filing Date: 13 November 1995 (13.11.95)</p> <p>(30) Priority Data: 08/348,543 1 December 1994 (01.12.94) US</p> <p>(71) Applicant: MICRON COMMUNICATIONS, INC. [US/US]; 8000 S. Federal Way, Boise, ID 83706-9632 (US).</p> <p>(72) Inventor: TUTTLE, Mark, E.; 1998 Table Rock Road, Boise, ID 83712 (US).</p> <p>(74) Agent: FLETCHER, Michael, G.; P.O. Box 4433, Houston, TX 77210 (US).</p>	<p>(81) Designated States: AL, AM, AT, AU, BB, BG, BR, BY, CA, CH, CN, CZ, DE, DK, EE, ES, FI, GB, GE, HU, IS, JP, KE, KG, KP, KR, KZ, LK, LR, LS, LT, LU, LV, MD, MG, MK, MN, MW, MX, NO, NZ, PL, PT, RO, RU, SD, SE, SG, SI, SK, TJ, TM, TT, UA, UG, UZ, VN, European patent (AT, BE, CH, DE, DK, ES, FR, GB, GR, IE, IT, LU, MC, NL, PT, SE), OAPI patent (BF, BJ, CF, CG, CI, CM, GA, GN, ML, MR, NE, SN, TD, TG), ARIPO patent (KE, LS, MW, SD, SZ, UG).</p> <p>Published <i>With international search report. Before the expiration of the time limit for amending the claims and to be republished in the event of the receipt of amendments.</i></p>	

(54) Title: METHOD OF FORMING BUTTON-TYPE BATTERIES AND A BUTTON-TYPE BATTERY INSULATING AND SEALING GASKET



(57) Abstract

A method of forming a button-type battery includes: a) positioning first and second terminal housing members in facing juxtaposition to one another, and providing an anode, a cathode and an electrolyte intermediate the first and second terminal housing member central portions; b) providing a peripheral insulative sealing gasket intermediate the first and second terminal housing members, the insulative sealing gasket being in the shape of an annulus and having a radial extent which extends radially outward beyond the surrounding peripheral portions of the first and second terminal housing members; c) moving at least one of the juxtaposed first and second terminal housing members in the direction of the other to push the first terminal housing member container wall against the first gasket face and to simultaneously force the second terminal housing member peripheral portion against the second gasket face, and continuing such moving to bend the insulative gasket about the container wall and force it to be received within the first terminal housing member; and d) after the moving step, crimping the container wall and sealing gasket against the peripheral portion of the second terminal housing member to form an enclosed housing. An alternate method includes: i) providing a discrete, pre-formed peripheral insulative sealing gasket in the shape of an annulus; and ii) positioning the discrete, pre-formed sealing gasket within the first terminal housing member, then crimping to seal. A novel gasket construction is also disclosed.

FOR THE PURPOSES OF INFORMATION ONLY

Codes used to identify States party to the PCT on the front pages of pamphlets publishing international applications under the PCT.

AT	Austria	GB	United Kingdom	MR	Mauritania
AU	Australia	GE	Georgia	MW	Malawi
BB	Barbados	GN	Guinea	NE	Niger
BE	Belgium	GR	Greece	NL	Netherlands
BF	Burkina Faso	HU	Hungary	NO	Norway
BG	Bulgaria	IE	Ireland	NZ	New Zealand
BJ	Benin	IT	Italy	PL	Poland
BR	Brazil	JP	Japan	PT	Portugal
BY	Belarus	KE	Kenya	RO	Romania
CA	Canada	KG	Kyrgystan	RU	Russian Federation
CF	Central African Republic	KP	Democratic People's Republic of Korea	SD	Sudan
CG	Congo	KR	Republic of Korea	SE	Sweden
CH	Switzerland	KZ	Kazakhstan	SI	Slovenia
CI	Côte d'Ivoire	LI	Liechtenstein	SK	Slovakia
CM	Cameroon	LK	Sri Lanka	SN	Senegal
CN	China	LU	Luxembourg	TD	Chad
CS	Czechoslovakia	LV	Latvia	TG	Togo
CZ	Czech Republic	MC	Monaco	TJ	Tajikistan
DE	Germany	MD	Republic of Moldova	TT	Trinidad and Tobago
DK	Denmark	MG	Madagascar	UA	Ukraine
ES	Spain	ML	Mali	US	United States of America
FI	Finland	MN	Mongolia	UZ	Uzbekistan
FR	France			VN	Viet Nam
GA	Gabon				

5

10 **METHOD OF FORMING BUTTON-TYPE BATTERIES AND A
 BUTTON-TYPE BATTERY INSULATING AND SEALING GASKET**

 This invention relates to methods of forming button-type batteries and to
button-type battery insulating and sealing gaskets.

15

 Button-type batteries are small, thin energy cells that are commonly used in
watches and other electronic devices requiring a thin profile. A conventional
button-type battery includes two electrodes in the form of an anode and a cathode.
These are typically separated by a porous separator. An electrolyte is present within
20 pores of the separator.

25

 These internal battery components are housed within a metal casing or housing
formed by a lower conductive can and an upper conductive lid. A common prior art
material for the can and lid is stainless steel. The can is typically in electrical contact
with the cathode to form the positive battery terminal, and the lid is in electrical
contact with the anode to form the negative battery terminal. The can and lid are
crimped or pressed together to form a fluid-tight seal which entirely encloses the
anode, cathode, separator, and electrolyte. An electrically insulating sealing gasket
is provided within the primary seal between the lid and can to electrically isolate the
30 two housing members.

 This invention principally concerns the provision of the sealing gasket material
within the crimp.

Preferred embodiments of the invention are described below with reference to the following accompanying drawings.

Fig. 1 is an, exploded fragmentary cross-sectional view of button-type battery components illustrative of a method of forming a button-type battery in accordance with an aspect of the invention.

Fig. 2 is a top view of a gasket component of Fig. 1.

Fig. 3 is a fragmentary sectional view of button-type battery components in position in a method of forming a button-type battery in accordance with the invention.

Fig. 4 is a fragmentary sectional view of button-type battery components in position in an alternate method of forming a button-type battery in accordance with the invention.

Fig. 5 is a fragmentary sectional view of button-type battery components in process during a method of forming a button-type battery in accordance with the invention.

Fig. 6 is a view of the Fig. 5 battery components at a point in time subsequent to the processing step illustrated by Fig. 5.

Fig. 7 is a view of the Fig. 5 battery components at a point in time subsequent to the processing step illustrated by Fig. 6.

Fig. 8 is a sectional view of a button-type battery produced in accordance with a method of the invention, and differs from the Fig. 7 construction in utilization of an alternate sized sealing gasket.

Fig. 9 is a fragmentary side sectional view of a discrete, pre-formed peripheral insulating sealing gasket utilized in an alternate method of forming a button-type battery in accordance with another aspect of the invention.

5 Fig. 10 is reduced scale top view of the Fig. 9 sealing gasket.

Fig. 11 is a fragmentary exploded view of button-type battery components, including the gasket of Figs. 9 and 10, positioned for assembly in accordance with an aspect of the invention.

10

Fig. 12 is a side sectional view of the components of Fig. 11 shown in process during a method of forming a button-type battery in accordance with an aspect of the invention.

15

Fig. 13 is a fragmentary sectional view of button-type battery components of Fig. 11 shown in a finished assembled state.

Fig. 14 is a side sectional view of a button-type battery insulative sealing gasket in accordance with the invention.

20

Fig. 15 is an enlarged view of a portion of the button-type battery insulative sealing gasket of Fig. 14.

25 Fig. 16 is a view of the Fig. 14 gasket at the Fig. 15 scale, and illustrates the gasket in a sealed or crimped relationship with respect to first and second button-type battery terminal housing members.

30 This disclosure of the invention is submitted in furtherance of the constitutional purposes of the U.S. Patent Laws "to promote the progress of science and useful arts" (Article 1, Section 8).

In accordance with a first aspect of the invention, a method of forming a button-type battery comprises the following steps:

5 providing a conductive first terminal housing member having a surrounding peripheral portion and a central portion intermediate the surrounding peripheral portion, the surrounding peripheral portion comprising a transversely projecting peripheral container wall;

10 providing a conductive second terminal housing member having a surrounding peripheral portion and a central portion intermediate its surrounding peripheral portion;

15 positioning the second terminal housing member and the first terminal housing member in facing juxtaposition to one another, and providing an anode, a cathode and an electrolyte intermediate the first and second terminal housing member central portions;

20 providing a peripheral insulative sealing gasket intermediate the first and second terminal housing members, the insulative sealing gasket being in the shape of an annulus and having a radial extent which extends radially outward beyond the surrounding peripheral portions of the first and second terminal housing members, the insulative sealing gasket having opposing first and second faces, the first face facing the first terminal housing member, the second face facing the second terminal housing member;

25 moving at least one of the juxtaposed first and second terminal housing members in the direction of the other to push the first terminal housing member container wall against the first gasket face and to simultaneously force the second terminal housing member peripheral portion against the second gasket face, and continuing such moving to

30

bend the insulative gasket about the container wall and force it to be received within the first terminal housing member; and

5 after the moving step, crimping the container wall and sealing gasket against the peripheral portion of the second terminal housing member to form an enclosed housing which retains and protects the anode, cathode and electrolyte; the insulative gasket insulatively sealing between the crimped container wall and the second terminal housing member peripheral portion.

10

In accordance with another aspect of the invention, a method of forming a button-type battery comprises the following steps:

15 providing a conductive first terminal housing member having a surrounding peripheral portion and a central portion intermediate the surrounding peripheral portion, the surrounding peripheral portion comprising a transversely projecting peripheral container wall;

20 providing a conductive second terminal housing member having a surrounding peripheral portion and a central portion intermediate its surrounding peripheral portion;

25 providing a discrete, pre-formed peripheral insulative sealing gasket, the gasket being in the shape of an annulus and- comprising at least in part a substantially annular "L" cross sectional shape defining an annular "L" base portion and an annular "L" stem portion;

30 positioning the discrete, pre-formed sealing gasket within the first terminal housing member with the "L" stem portion extending internally along the container peripheral wall;

5 positioning the second terminal housing member and the first terminal housing member in facing juxtaposition to one another, and providing an anode, a cathode and an electrolyte intermediate the first and second terminal housing member central portions, the second terminal housing member peripheral portion being received against the "L" base portion of the positioned sealing gasket; and

10 crimping the container wall and sealing gasket against the peripheral portion of the second terminal housing member to form an enclosed housing which retains and protects the anode, cathode and electrolyte; the insulative gasket insulatively sealing between the crimped container wall and the second terminal housing member peripheral portion.

15 In accordance with still a further aspect of the invention, a button-type battery insulative sealing gasket comprises:

an annular body at least a portion of which has a substantially "L" cross sectional shape;

20 the "L" cross sectional shape defining an annular "L" base portion, the "L" base portion being configured to receive an inner sealing portion of a peripheral portion of a button-type battery terminal lid, the "L" base portion having a radial length and an inner radial portion and an outer radial portion;

25 the "L" cross sectional shape defining an annular "L" stem portion, the "L" stem portion being configured to receive an outer sealing portion of a peripheral portion of a button-type battery terminal lid, the "L" stem portion having a transverse length and an inner transverse portion and
30 an outer transverse portion; and

the "L" base portion having a thickness which varies along its radial length, the base thickness being greater at the inner radial portion than at the outer radial portion.

5 More particularly and first with reference to Figs. 1 and 2, button-type battery components for assembly are indicated generally with reference numeral 10. Such are comprised of a first terminal housing member 12 having a surrounding peripheral portion 14 and a central portion 16 intermediate surrounding peripheral portion 14. Portion 14 is in the form of a substantially normal peripheral container wall which
10 projects transversely relative to central portion 16. In the illustrated embodiment, container wall 14 projects to a first distance 18 relative to central portion 16. An example first distance 18 would be 0.033 inches.

The button-type battery components also include a second terminal housing
15 member 20 having a surrounding peripheral portion 22 and a central portion 24 intermediate peripheral portion 22. Conventionally in the art, first terminal housing member 12 is commonly referred to as a "container" or "can", while second terminal housing member 20 is typically referred to as a "lid". Second terminal housing member 20 and first terminal housing member 12 are positioned in opposing facing
20 juxtaposition to one another. An anode 26, a cathode 28 and liquid electrolyte 30 are provided intermediate first and second terminal housing member central portions 16 and 24, respectively. A porous separator 32 is also typically provided intermediate cathode 28 and anode 26. Components 26, 28, 30 and 32 could be provided either within first terminal housing member 12 or second terminal housing member 20, with
25 positioning relative to second terminal housing member 20 being shown and preferred.

A peripheral sealing gasket 34 is provided intermediate first terminal housing member 12 and second terminal housing member 20. Gasket 34 is in the shape of
30 an annulus, and has a radial extent 36 which extends radially outward beyond surrounding peripheral portions 14 and 22, as shown. Radial extent 36 defines a

second distance which is less than first distance 18. Gasket 34 has opposing first and second faces 38, 40, respectively, with first face 38 facing first terminal housing member 12 and second face 40 facing second terminal housing member 20. Gasket 34 is of constant thickness (Fig. 1) and has a constant outer radius (Fig. 2).

5

Preferred techniques for providing and positioning the gasket intermediate the housing members are described with reference to Figs. 3 and 4. In one embodiment 10a shown in Fig. 3, gasket second face 40 is adhered against second terminal housing member peripheral portion 22 prior to the step of positioning the first and second terminal housing members in juxtaposition to one another. An example and preferred adhesive is a tacky asphalt, such as Pioneer 760™ made by Pioneer Asphalt Company of Lawrenceville, Illinois. In an alternate embodiment 10b as shown in Fig. 4, gasket first face 38 is placed against container wall 14 prior to the step of positioning the first and second terminal members in juxtaposition to one another. Again, preferably an adhesive such as the above Pioneer 760™ is used intermediate gasket first face 38 and container wall 14 for temporarily retaining gasket 34 in the illustrated position. The adhesive should not, however, be so strong as to prevent subsequent breaking and sliding of gasket 34 relative to walls 14, as will be apparent from the continuing discussion. Preferably, the anode, the cathode, the electrolyte, and the separator are positioned relative to one of the first or second housing members before the step of providing gasket 34 in its intermediate position.

Referring to Figs. 5-7, at least one of juxtaposed first terminal housing member 12 or second terminal housing member 20 is moved in the direction of the other to push first terminal housing member peripheral wall 14 against first gasket face 38 and to simultaneously force second terminal housing member peripheral portion 22 against second gasket face 40. This will cause sliding movement of first gasket face 38 relative to the outer edge of container wall 14, as well as bending of gasket 34 (Fig. 5). Such movement is continued to bend insulative gasket 34 about container wall 14 and force gasket 34 to be received within first terminal housing member 12 (Fig. 6). After such bending and placement of gasket 34 within first

container 12, container wall 14 and adjoining sealing gasket material 34 are crimped against peripheral portion 22 of second terminal housing member 20 (Fig. 7) to form an enclosed housing which retains and protects the anode, cathode and electrolyte. Insulative gasket 34 insulatively seals between crimped container wall 14 and second terminal housing member peripheral portion 22. Fig. 7 illustrates a finished construction designated with numeral 45.

Referring to Figs. 1 and 7, second distance 36 is preferably gauged to be less than first distance 18 such that upon finished folding and crimping, the outer terminus of gasket 34 aligns with the outer terminus of crimped container wall 14. Due to container wall 14 being bent about an effective larger radius than gasket 34, second distance 36 will be less than first distance 18 to accomplish such objective.

Fig. 8 illustrates an alternate embodiment 45a whereby second distance 36 is greater than or equal to first distance 18. As shown, gasket 34a has an outer terminus which projects outwardly beyond the terminus of container wall 14 after crimping. Such would provide an advantage of positioning insulative material between can 12 and lid 20 in this region. In either embodiment if desired, gasket 34 can be constructed to extend radially inward to contact the outer radial edge of cathode 28, thereby providing an alignment function within the housing relative for cathode 28.

A method of forming a button-type battery as described above enables the gasket to be made from extremely thin sheet stock, and minimizes final battery thickness. Preferred thickness is from 2 to 4 mils. Polypropylene is a preferred material which can be formed by cold pressing or hot pressing. Current button-type battery gaskets in industry are formed by injection molding, and are difficult to produce in desired shapes at thicknesses less than 7 mils.

An alternate embodiment and method of construction are described with reference to Figs. 9-13. For simplification and ease of discussion, no anode, cathode,

or electrolyte are shown with respect to the construction. Like numerals from the first-described embodiments are utilized where appropriate, with differences of construction being indicated with different numerals. An insulative sealing gasket 50 is provided as a discrete, pre-formed mass in the shape of an annulus. Such comprises at least in part a substantially annular "L" cross-sectional shape, defining an annular "L" base portion 52 and an annular "L" stem portion 54.

Referring to Fig. 12, discrete pre-formed sealing gasket 50 is positioned within first terminal housing - member 12 with "L" stem portion 54 extending internally along container peripheral wall 14. Preferably, gasket base 52 is adhered by a tacky adhesive to first terminal housing member 12, with the Pioneer 760™ being an example. Second terminal housing member 20 is moved into facing juxtaposition against "L" base portion 52 of sealing gasket 50.

Referring to Fig. 13, container wall 14 and gasket stem 54 are crimped against peripheral portion 22 of second terminal housing member 20 to form an enclosing housing which retains and protects the anode, cathode and the electrolyte (not shown). The finished construction is indicated with numeral 51. A preferred material of construction is polypropylene having from 1% to 3% ethylene.

In accordance with another aspect of the invention, a preferred embodiment button-type battery insulative sealing gasket is indicated generally with reference numeral 56 in Figs. 14-16. Such is comprised of an annular body 58 having a substantially "L" cross-sectional shape. The "L" cross-sectional shape defines an annular "L" base portion 60 and an annular "L" stem portion 70. Base portion 60 is configured to receive an inner sealing portion of a peripheral portion 22 of a button-type battery terminal lid 20 for which the gasket is principally adapted. "L" base portion 60 has a radial length 62 (Fig. 15) and, for purposes of discussion, has an inner radial portion 64 and an outer radial portion 66.

Base portion 60 has a thickness which varies along its radial length 62, being greater at inner radial portion 64 than at outer radial portion 66. The illustrated change in the base portion thickness preferably occurs along a base arc 68 which is sized and shaped to mate with a correspondingly shaped arc of peripheral portion 22 of button-type a battery terminal lid 20 for which gasket 56 is adapted.

Stem portion 70 is configured to receive an outer sealing portion or surface 99 (Fig. 15) of peripheral portion 22 of button-type battery terminal lid 20. Stem portion 70 has a transverse length 72 which, for purposes of the continuing discussion, defines an inner transverse portion 76 and an outer transverse portion 78. "L" stem portion 70 also has a thickness which varies along its transverse length 72, with the stem thickness being greater at inner transverse portion 76 than at outer transverse portion 78. The thickness change for stem portion 70 occurs at a substantially perpendicular step 80, as opposed to along an arc as occurs in the base portion. Stem portion 70 angles from base portion 60 at slightly greater than 90°. This makes it easier to insert gasket 56 into the can and prevent stem portion 70 from folding inward and interfering with lid insertion.

Referring to Fig. 16, the components are positioned and crimped as shown to produce a peripheral seal for a button-type battery. Such a gasket construction provides two advantages. First, the greater mass of material defined at the gasket fold by step 80 substantially completely fills any outer void between lid 20 and can 12. Second, the enlarged inner radial portion of base 60 defined by arc 68 can be utilized to engage the outer radial edge of the cathode (not shown) to provide an alignment function with the battery to such cathode.

In compliance with the statute, the invention has been described in language more or less specific as to structural and methodical features. It is to be understood, however, that the invention is not limited to the specific features shown and described, since the means herein disclosed comprise preferred forms of putting the invention into effect. The invention is, therefore, claimed in any of its forms or

modifications within the proper scope of the appended claims appropriately interpreted in accordance with the doctrine of equivalents.

CLAIMS:

1. A method of forming a button-type battery comprising the following steps:
 - 5 providing a conductive first terminal housing member having a surrounding peripheral portion and a central portion intermediate the surrounding peripheral portion, the surrounding peripheral portion comprising a transversely projecting peripheral container wall;
 - 10 providing a conductive second terminal housing member having a surrounding peripheral portion and a central portion intermediate its surrounding peripheral portion;
 - 15 positioning the second terminal housing member and the first terminal housing member in facing juxtaposition to one another, and providing an anode, a cathode and an electrolyte intermediate the first and second terminal housing member central portions;
 - 20 providing a peripheral insulative sealing gasket intermediate the first and second terminal housing members, the insulative sealing gasket being in the shape of an annulus and having a radial extent which extends radially outward beyond the surrounding peripheral portions of the first and second terminal housing members, the insulative sealing gasket having opposing first and second faces, the first face facing the first
25 terminal housing member, the second face facing the second terminal housing member;
 - 30 moving at least one of the juxtaposed first and second terminal housing members in the direction of the other to push the first terminal housing member container wall against the first gasket face and to simultaneously force the second terminal housing member peripheral

portion against the second gasket face, and continuing such moving to bend the insulative gasket about the container wall and force it to be received within the first terminal housing member; and

5 after the moving step, crimping the container wall and sealing gasket against the peripheral portion of the second terminal housing member to form an enclosed housing which retains and protects the anode, cathode and electrolyte; the insulative gasket insulatively sealing between the crimped container wall and the second terminal housing member
10 peripheral portion.

2. The method of forming a button-type battery of claim 1 wherein the annulus has a constant thickness and a constant outer radius.

15

3. The method of forming a button-type battery of claim 1 wherein the container wall projects transversely relative to the first terminal housing member central portion to a first distance, and the annulus in intermediate position projects radially outward
20 relative to the container wall to a second distance, the second distance being less than the first distance.

4. The method of forming a button-type battery of claim 1 wherein the container wall projects transversely relative to the first terminal housing member central portion
25 to a first distance, and the annulus in intermediate position projects radially outward relative to the container wall to a second distance, the second distance being greater than or equal to the first distance.

30

5. The method of forming a button-type battery of claim 1 wherein,

the annulus has a constant thickness and a constant outer radius; and

the container wall projects transversely relative to the first terminal housing member central portion to a first distance, and the annulus in intermediate position projects radially outward relative to the container wall to a second distance, the second distance being less than the first distance.

5

10 6. The method of forming a button-type battery of claim 1 wherein,

the annulus has a constant thickness and a constant outer radius; and

the container wall projects transversely relative to the first terminal housing member central portion to a first distance, and the annulus in intermediate position projects radially outward relative to the container wall to a second distance, the second distance being greater than or equal to the first distance.

15

20

7. The method of forming a button-type battery of claim 1 wherein the anode, the cathode and the electrolyte are positioned relative to one of the first or second housing members before the step of providing the gasket in intermediate position.

25

8. The method of forming a button-type battery of claim 1 wherein the step of providing the gasket comprises placing the gasket first face against the container wall prior to the step of positioning the first and second terminal housing members in juxtaposition to one another.

30

9. The method of forming a button-type battery of claim 8 further comprising providing a tack adhesive intermediate the gasket first face and container wall.

5 10. The method of forming a button-type battery of claim 1 wherein the step of providing the gasket comprises adhering the gasket second face against the second terminal housing member peripheral portion prior to the step of positioning the first and second terminal housing members in juxtaposition to one another.

10

11. The method of forming a button-type battery of claim 1 wherein,

15

the container wall projects transversely relative to the first terminal housing member central portion to a first distance, and the annulus in intermediate position projects radially outward relative to the container wall to a second distance, the second distance being less than the first distance; and

20

the step of providing the gasket comprises placing the gasket first face against the container wall prior to the step of positioning the first and second terminal housing members in juxtaposition to one another.

25

12. The method of forming a button-type battery of claim 1 wherein,

30

the container wall projects transversely relative to the first terminal housing member central portion to a first distance, and the annulus in intermediate position projects radially outward relative to the container wall to a second distance, the second distance being greater than or equal to the first distance; and

the step of providing the gasket comprises placing the gasket first face against the container wall prior to the step of positioning the first and second terminal housing members in juxtaposition to one another.

5

13. The method of forming a button-type battery of claim 1 wherein,

the container wall projects transversely relative to the first terminal housing member central portion to a first distance, and the annulus in intermediate position projects radially outward relative to the container wall to a second distance, the second distance being less than the first distance; and

10

the step of providing the gasket comprises adhering the gasket second face against the second terminal housing member peripheral portion prior to the step of positioning the first and second terminal housing members in juxtaposition to one another.

15

20 14. The method of forming a button-type battery of claim 1 wherein,

the container wall projects transversely relative to the first terminal housing member central portion to a first distance, and the annulus in intermediate position projects radially outward relative to the container wall to a second distance, the second distance being greater than or equal to the first distance; and

25

the step of providing the gasket comprises adhering the gasket second face against the second terminal housing member peripheral portion prior to the step of positioning the first and second terminal housing members in juxtaposition to one another.

30

15. A method of forming a button-type battery comprising the following steps:

5 providing a conductive first terminal housing member having a surrounding peripheral portion and a central portion intermediate the surrounding peripheral portion, the surrounding peripheral portion comprising a transversely projecting peripheral container wall;

10 providing a conductive second terminal housing member having a surrounding peripheral portion and a central portion intermediate its surrounding peripheral portion;

15 providing a discrete, pre-formed peripheral insulative sealing gasket, the gasket being in the shape of an annulus and comprising at least in part a substantially annular "L" cross sectional shape defining an annular "L" base portion and an annular "L" stem portion;

20 positioning the discrete, pre-formed sealing gasket within the first terminal housing member with the "L" stem portion extending internally along the container peripheral wall;

25 positioning the second terminal housing member and the first terminal housing member in facing juxtaposition to one another, and providing an anode, a cathode and an electrolyte intermediate the first and second terminal housing member central portions, the second terminal housing member peripheral portion being received against the "L" base portion of the positioned sealing gasket; and

30 crimping the container wall and sealing gasket against the peripheral portion of the second terminal housing member to form an enclosed housing which retains and protects the anode, cathode and electrolyte; the

insulative gasket insulatingly sealing between the crimped container wall and the second terminal housing member peripheral portion.

5 16. The method of forming a button-type battery of claim 15 wherein the annulus has a constant thickness and a constant outer radius.

10 17. The method of forming a button-type battery of claim 15 wherein the step of positioning the sealing gasket comprises adhering the "L" base portion to the first terminal housing member with an adhesive.

15 18. The method of forming a button-type battery of claim 15 wherein the pre-formed gasket comprises:

20 the "L" base portion being configured to receive an inner sealing portion of a peripheral portion of a button-type battery terminal lid, the "L" base portion having a radial length and an inner radial portion and an outer radial portion;

25 the "L" stem portion being configured to receive an outer sealing portion of a peripheral portion of a button-type battery terminal lid, the "L" stem portion having a transverse length and an inner transverse portion and an outer transverse portion; and

30 the "L" base portion having a thickness which varies along its radial length, the base thickness being greater at the inner radial portion than at the outer radial portion.

19. The method of forming a button-type battery of claim 18 wherein change in the base portion thickness occurs along a base arc, the base arc being sized and shaped to mate with a correspondingly shaped arc of the peripheral portion of a button-type battery terminal lid for which the gasket is adapted.

5

20. The method of forming a button-type battery of claim 18 wherein the "L" stem portion has a thickness which varies along its transverse length, the stem thickness being greater at the inner transverse portion than at the outer transverse portion.

10

21. The method of forming a button-type battery of claim 18 wherein,

change in the base portion thickness occurs along a base arc, the base arc
15 being sized and shaped to mate with a correspondingly shaped arc of
the peripheral portion of a button-type battery terminal lid for which
the gasket is adapted; and

the "L" stem portion has a thickness which varies along its transverse length,
20 the stem thickness being greater at the inner transverse portion than at
the outer transverse portion.

22. A button-type battery insulative sealing gasket comprising:

25

an annular body at least a portion of which has a substantially "L" cross
sectional shape; the "L" cross sectional shape defining an annular
"L" base portion, the "L" base portion being configured to receive an
inner sealing portion of a peripheral portion of a button-type battery
terminal lid, the "L" base portion having a radial length and an inner
30 radial portion and an outer radial portion;

the "L" cross sectional shape defining an annular "L" stem portion, the "L" stem portion being configured to receive an outer sealing portion of a peripheral portion of a button-type battery terminal lid, the "L" stem portion having a transverse length and an inner transverse portion and an outer transverse portion; and

the "L" base portion having a thickness which varies along its radial length, the base thickness being greater at the inner radial portion than at the outer radial portion.

23. The button-type battery insulative sealing gasket of claim 22 wherein the stem portion and base portion angle from one another at greater than 90° while maintaining a substantially L-shape.

24. The button-type battery insulative sealing gasket of claim 22 wherein change in the base portion thickness occurs along a base arc, the base arc being sized and shaped to mate with a correspondingly shaped arc of the peripheral portion of a button-type battery terminal lid for which the gasket is adapted.

25. The button-type battery insulative sealing gasket of claim 22 wherein the "L" stem portion has a thickness which varies along its transverse length, the stem thickness being greater at the inner transverse portion than at the outer transverse portion.

26. The button-type battery insulative sealing gasket of claim 25 wherein change in the stem portion thickness occurs at a substantially perpendicular step.

27. The button-type battery insulative sealing gasket of claim 22 wherein,

5 change in the base portion thickness occurs along a base arc, the base arc being sized and shaped to mate with a correspondingly shaped arc of the peripheral portion of a button-type battery terminal lid for which the gasket is adapted; and

10 the "L" stem portion has a thickness which varies along its transverse length, the stem thickness being greater at the inner transverse portion than at the outer transverse portion.

28. The button-type battery insulative sealing gasket of claim 27 wherein change in the stem portion thickness occurs at a substantially perpendicular step.

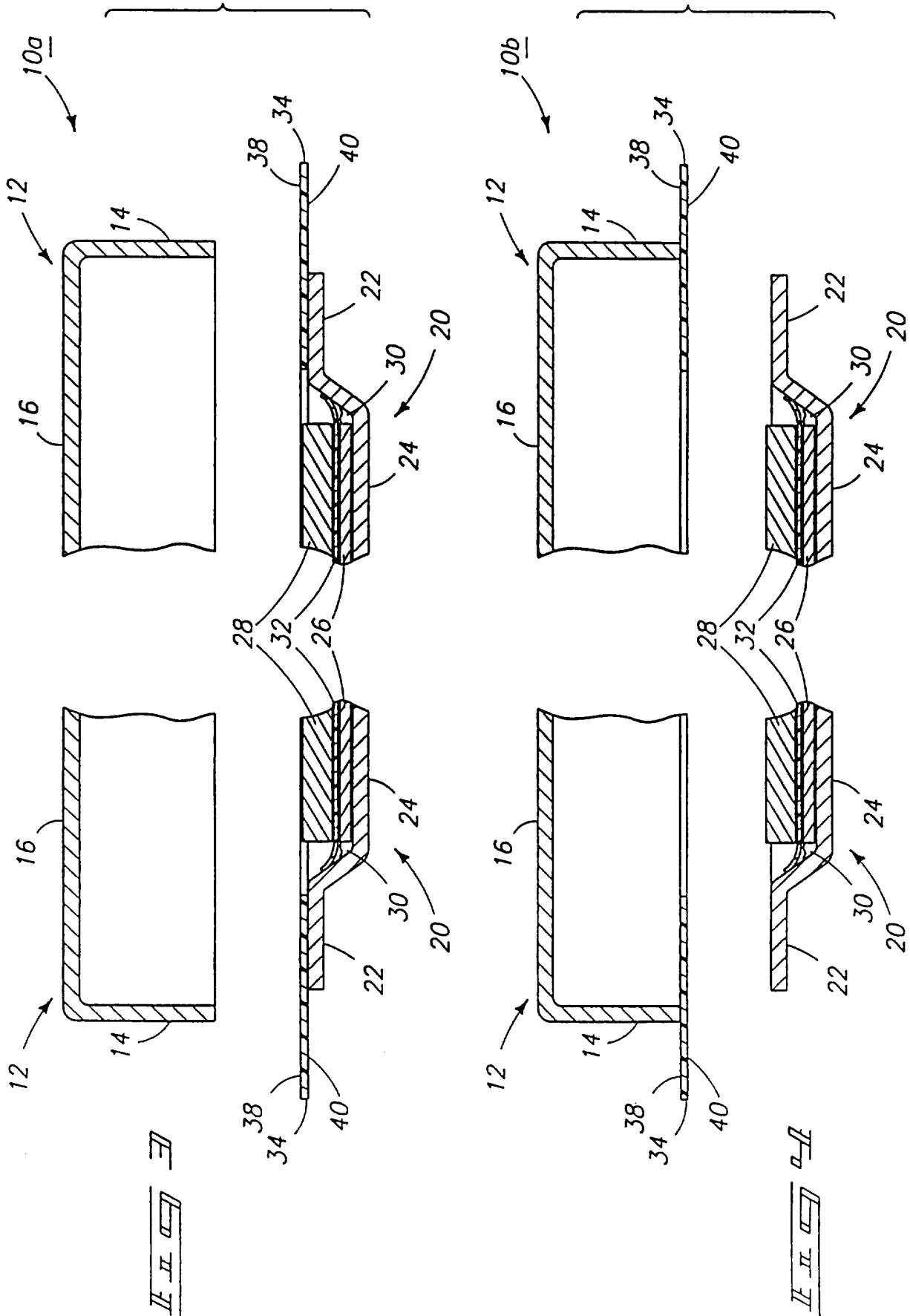

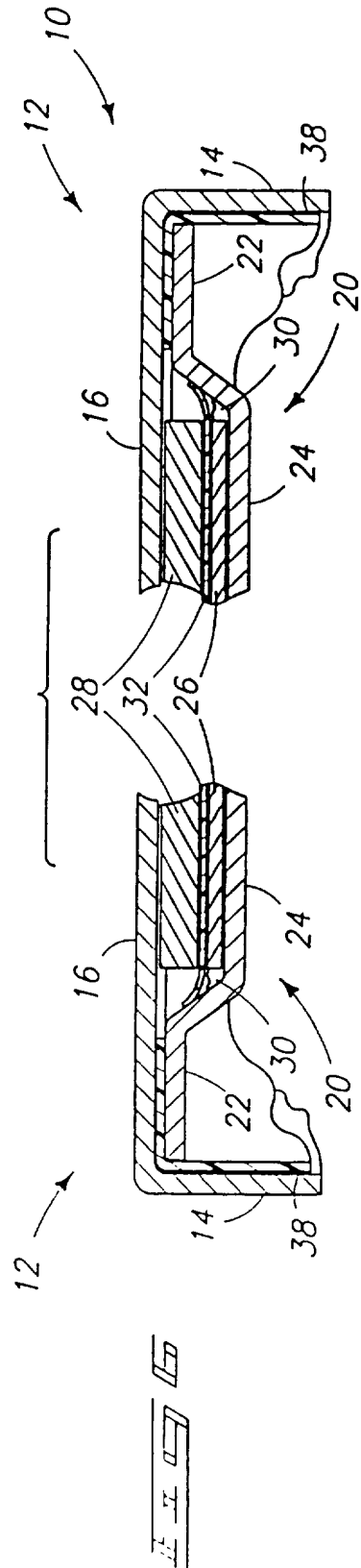
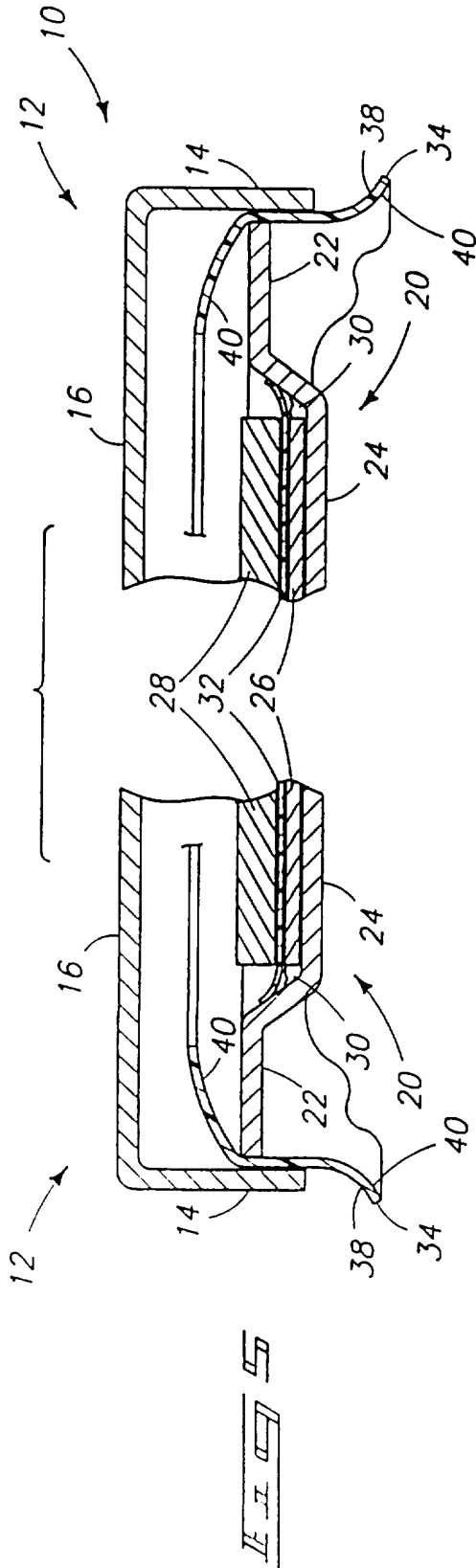

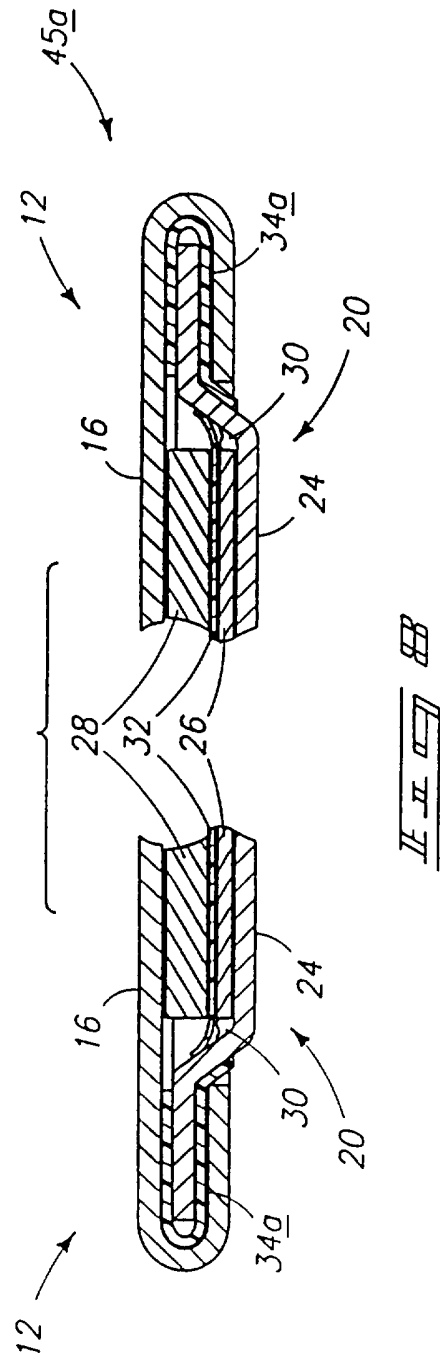
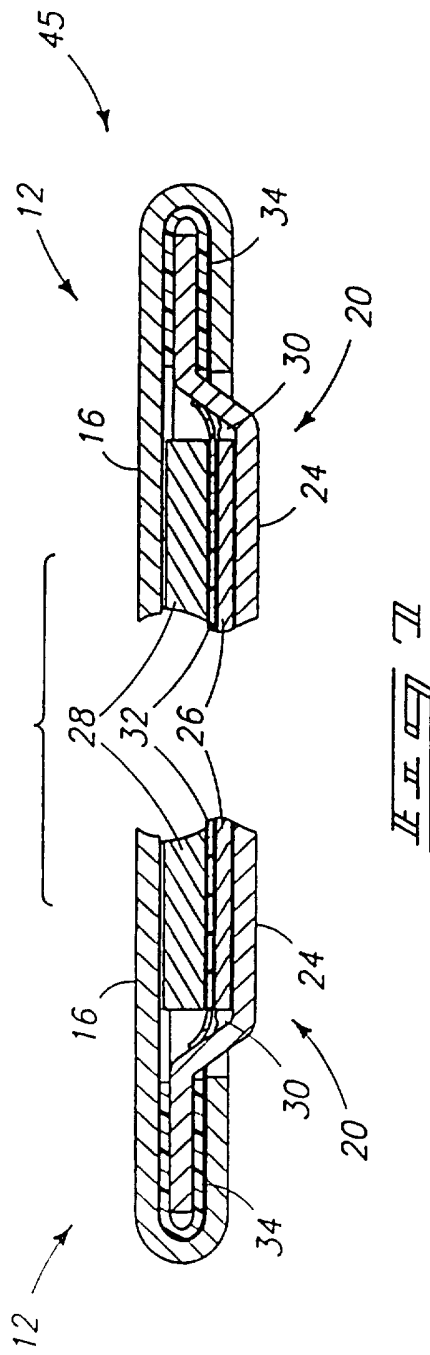

5/9

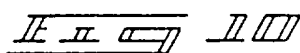
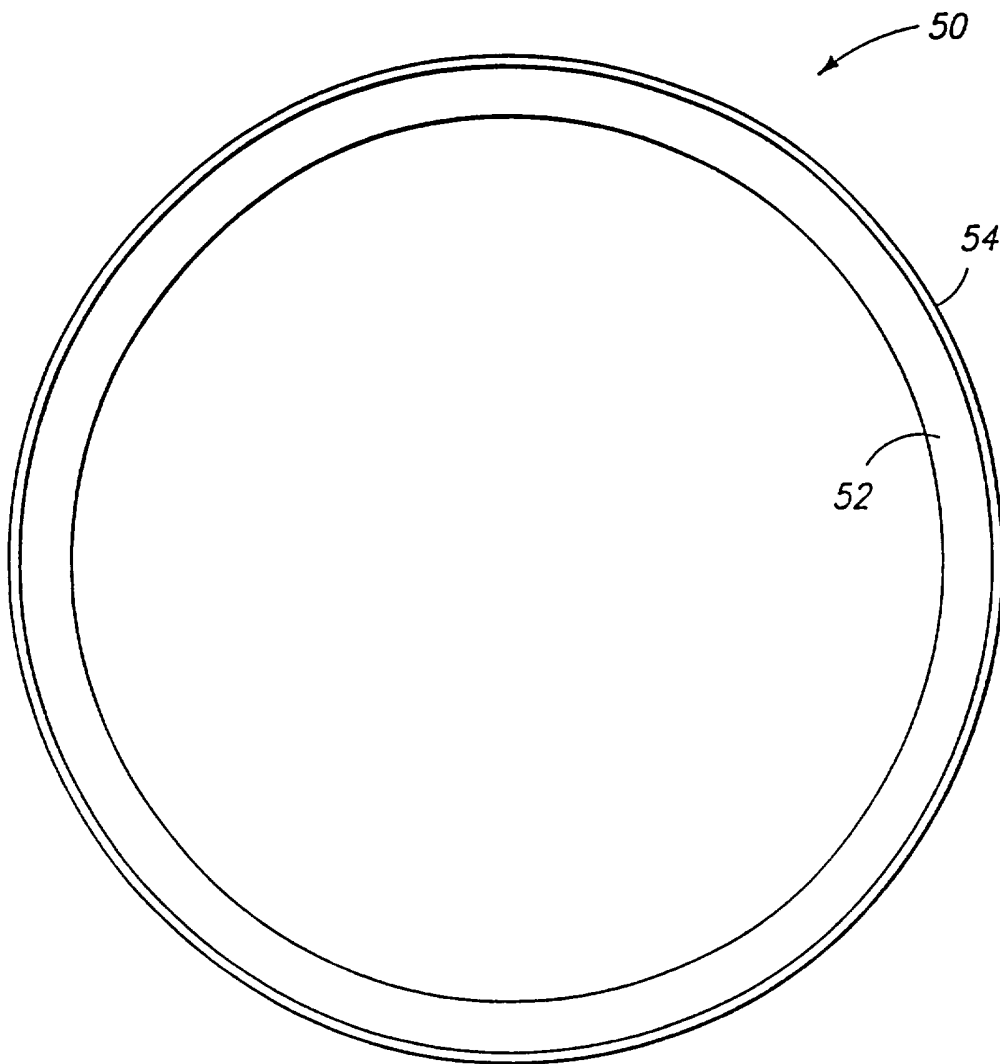
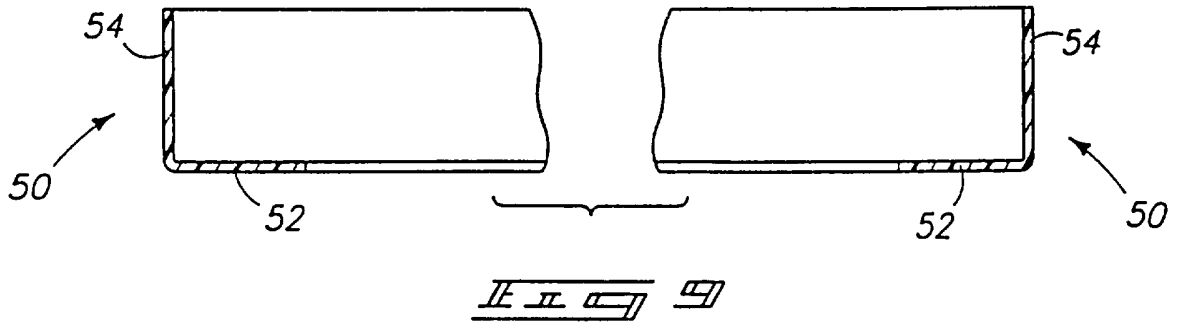

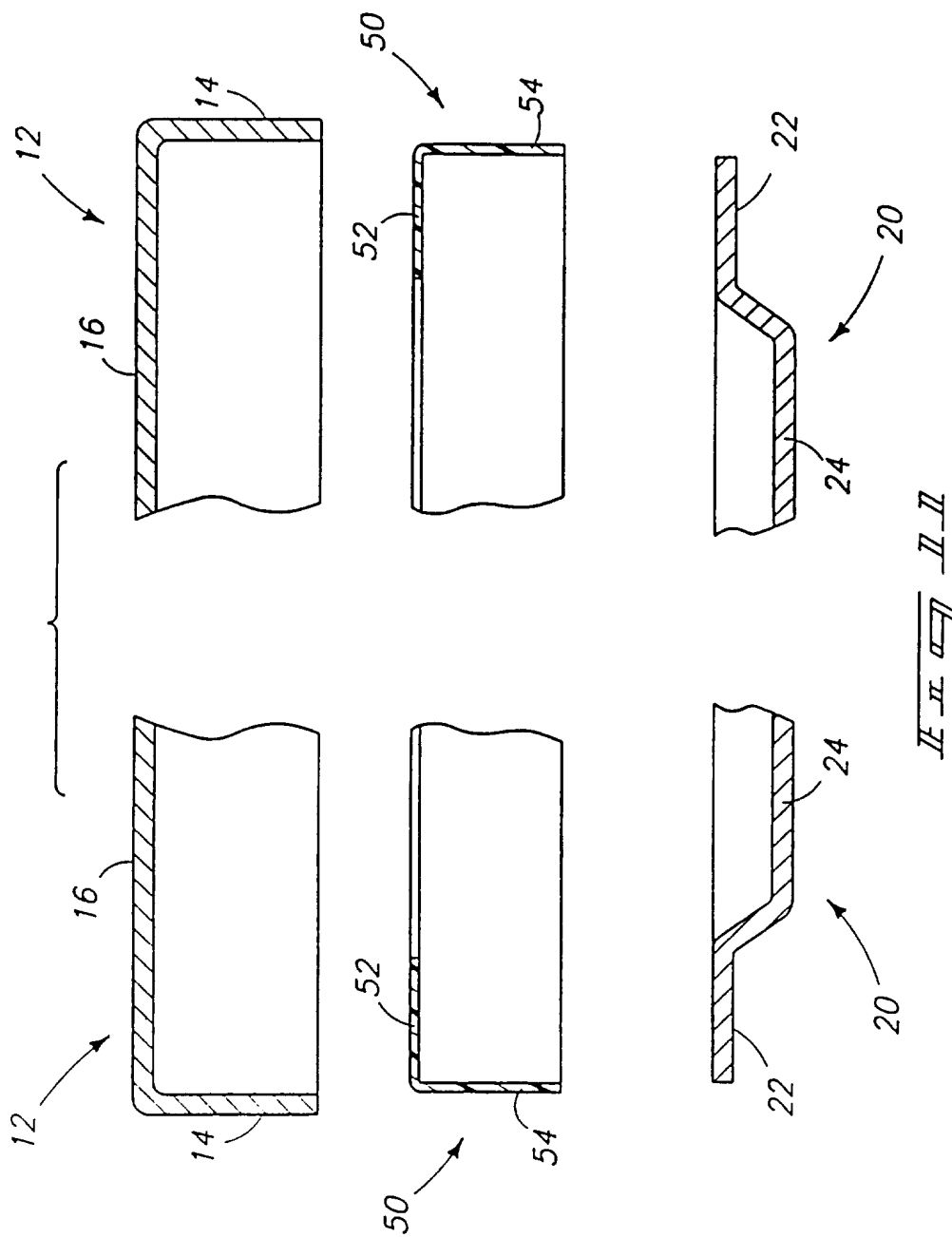

7/9

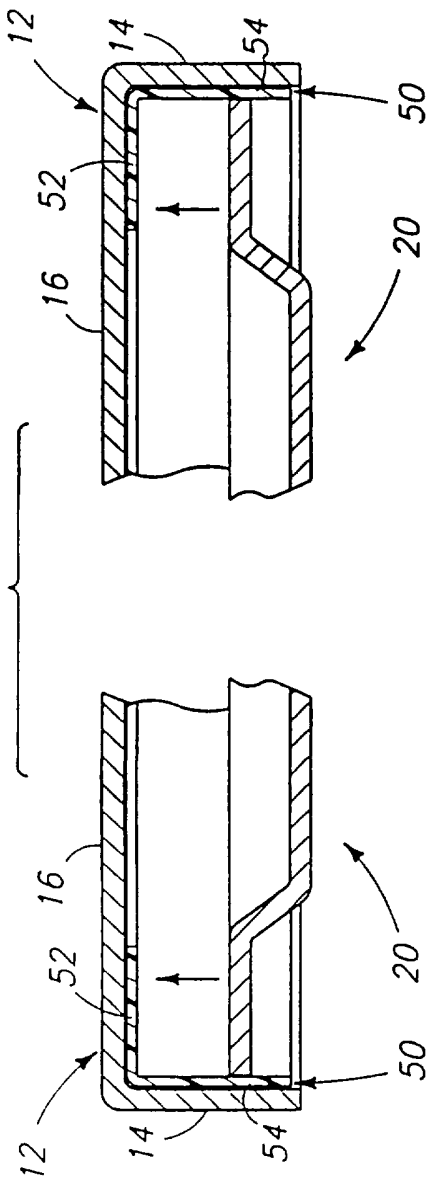

Fig. 11

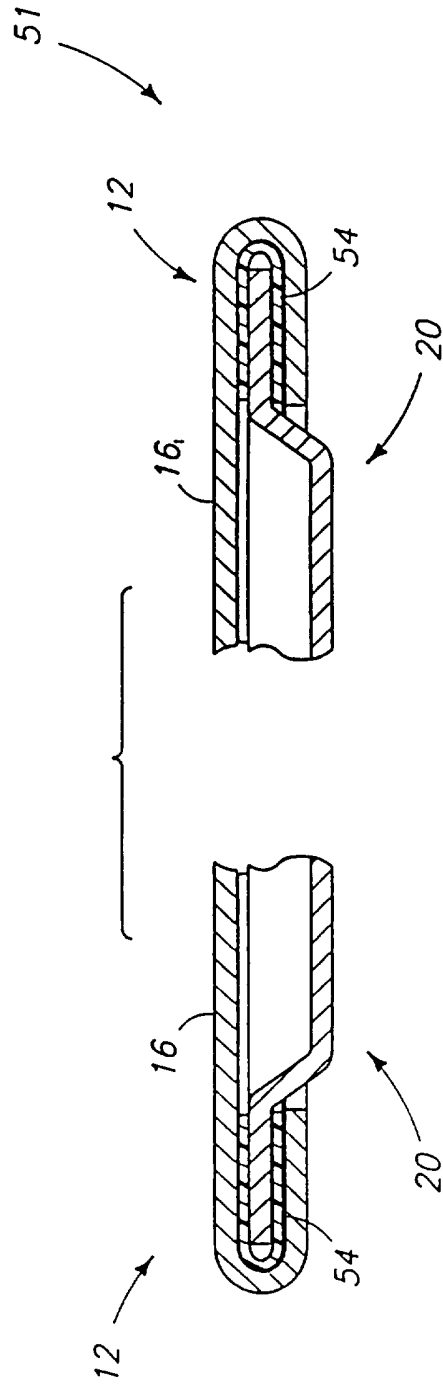

Fig. 12

8/9

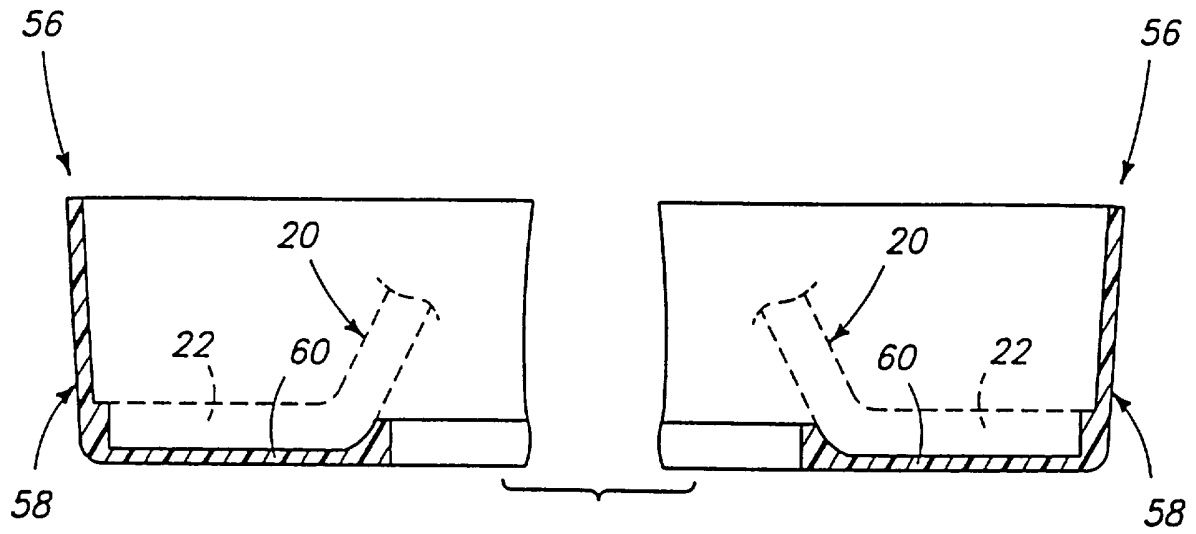

Fig. 14 Fig. 15

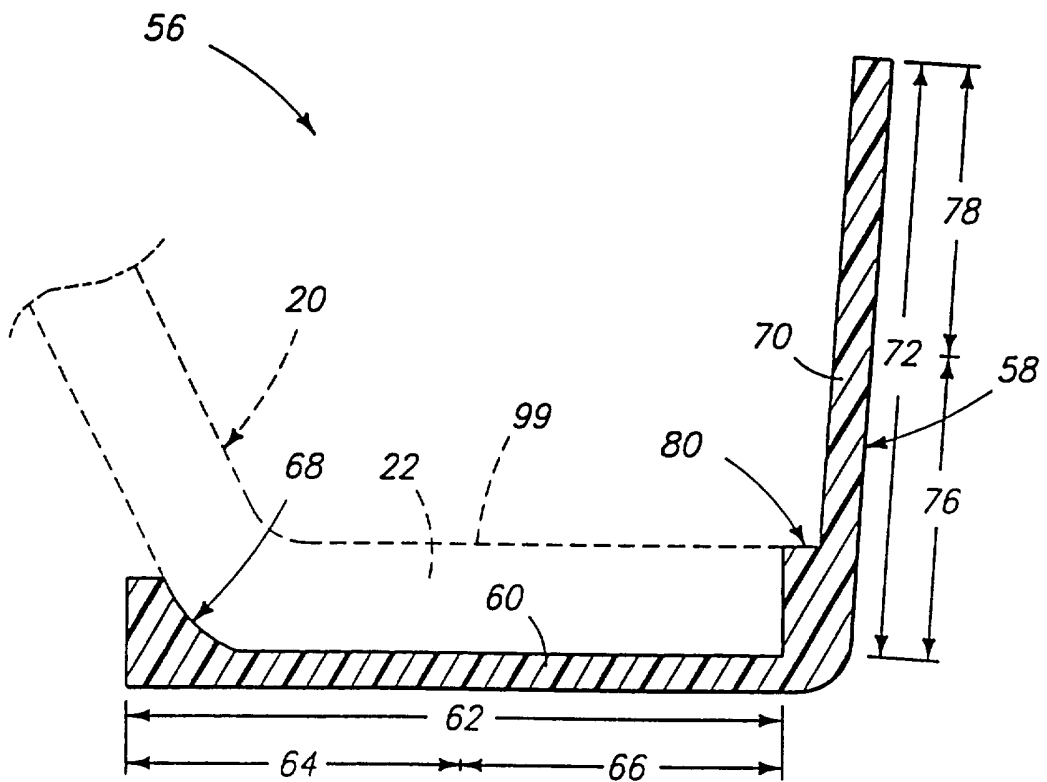
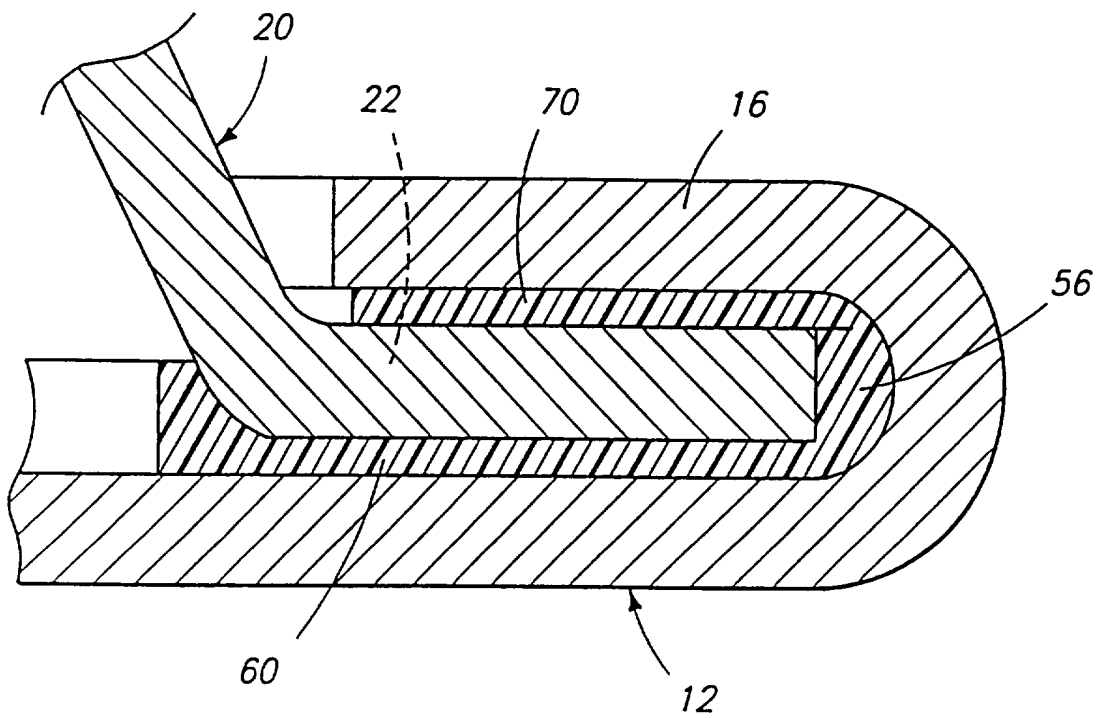

Fig. 14 Fig. 15



INTERNATIONAL SEARCH REPORT

International Application No
PCT/US 95/15192

A. CLASSIFICATION OF SUBJECT MATTER
IPC 6 H01M2/04 H01M2/02 H01M6/12

According to International Patent Classification (IPC) or to both national classification and IPC

B. FIELDS SEARCHED

Minimum documentation searched (classification system followed by classification symbols)
IPC 6 H01M

Documentation searched other than minimum documentation to the extent that such documents are included in the fields searched

Electronic data base consulted during the international search (name of data base and, where practical, search terms used)

C. DOCUMENTS CONSIDERED TO BE RELEVANT

Category *	Citation of document, with indication, where appropriate, of the relevant passages	Relevant to claim No.
X	EP,A,0 089 496 (UNION CARBIDE CORP) 28 September 1983	15,22
Y	see page 4, line 4 - page 8, line 10; figures 1-5	1,23-28
Y	--- PATENT ABSTRACTS OF JAPAN vol. 010 no. 367 (E-462), 9 December 1986 & JP,A,61 163559 (MATSUSHITA ELECTRIC IND CO LTD) 24 July 1986, see abstract	1
Y	--- EP,A,0 089 495 (UNION CARBIDE CORP) 28 September 1983 see claims 1-8; figure 3	23-28
A	--- US,A,3 741 812 (SANDEN G ET AL) 26 June 1973 see claims 1-10; figures 1,3-5 --- -/--	1-14

Further documents are listed in the continuation of box C.

Patent family members are listed in annex.

* Special categories of cited documents :

- *A* document defining the general state of the art which is not considered to be of particular relevance
- *E* earlier document but published on or after the international filing date
- *L* document which may throw doubts on priority claim(s) or which is cited to establish the publication date of another citation or other special reason (as specified)
- *O* document referring to an oral disclosure, use, exhibition or other means
- *P* document published prior to the international filing date but later than the priority date claimed

- *T* later document published after the international filing date or priority date and not in conflict with the application but cited to understand the principle or theory underlying the invention
- *X* document of particular relevance; the claimed invention cannot be considered novel or cannot be considered to involve an inventive step when the document is taken alone
- *Y* document of particular relevance; the claimed invention cannot be considered to involve an inventive step when the document is combined with one or more other such documents, such combination being obvious to a person skilled in the art.
- *&* document member of the same patent family

Date of the actual completion of the international search

4 April 1996

Date of mailing of the international search report

23. 04. 96

Name and mailing address of the ISA

European Patent Office, P.B. 5818 Patentlaan 2
NL - 2280 HV Rijswijk
Tel. (+ 31-70) 340-2040, Tx. 31 651 epo nl,
Fax (+ 31-70) 340-3016

Authorized officer

Battistig, M

INTERNATIONAL SEARCH REPORT

International Application No
PCT/US 95/15192

C.(Continuation) DOCUMENTS CONSIDERED TO BE RELEVANT		
Category	Citation of document, with indication, where appropriate, of the relevant passages	Relevant to claim No.
A	<p>PATENT ABSTRACTS OF JAPAN vol. 008 no. 088 (E-240) ,21 April 1984 & JP,A,59 008262 (MATSUSHITA DENKI SANGYO KK) 17 January 1984, see abstract -----</p>	15-28

INTERNATIONAL SEARCH REPORT

Information on patent family members

International Application No
PCT/US 95/15192

Patent document cited in search report	Publication date	Patent family member(s)	Publication date
EP-A-0089496	28-09-83	US-A- 4457990	03-07-84
		AU-B- 556781	20-11-86
		AU-B- 1266683	22-09-83
		DE-A- 3376716	23-06-88
		JP-A- 58172863	11-10-83

EP-A-0089495	28-09-83	AU-B- 556647	13-11-86
		AU-B- 1266783	22-09-83
		JP-A- 58169866	06-10-83
		US-A- 4656104	07-04-87

US-A-3741812	26-06-73	NONE	
