



(43) International Publication Date  
**30 June 2016 (30.06.2016)**

- (51) **International Patent Classification:**  
*G01R 31/36* (2006.01)    *H01M 10/48* (2006.01)
- (21) **International Application Number:**  
PCT/SG2014/000612
- (22) **International Filing Date:**  
23 December 2014 (23.12.2014)
- (25) **Filing Language:** English
- (26) **Publication Language:** English
- (71) **Applicant:** RAZER (ASIA-PACIFIC) PTE. LTD.  
[SG/SG]; 514 Chai Chee Lane, #07-05, Singapore 469029 (SG).
- (72) **Inventor:** TAN, Min-Liang; c/o Razer (Asia Pacific) Pte. Ltd., 514 Chai Chee Lane, #07-05, Singapore 469029 (SG).
- (74) **Agent:** VIERING, JENTSCHURA & PARTNER LLP; P.O. Box 1088, Rochor Post Office, Rochor Road, Singapore 911833 (SG).
- (81) **Designated States** (*unless otherwise indicated, for every kind of national protection available*): AE, AG, AL, AM,

AO, AT, AU, AZ, BA, BB, BG, BH, BN, BR, BW, BY, BZ, CA, CH, CL, CN, CO, CR, CU, CZ, DE, DK, DM, DO, DZ, EC, EE, EG, ES, FI, GB, GD, GE, GH, GM, GT, HN, HR, HU, ID, IL, IN, IR, IS, JP, KE, KG, KN, KP, KR, KZ, LA, LC, LK, LR, LS, LU, LY, MA, MD, ME, MG, MK, MN, MW, MX, MY, MZ, NA, NG, NI, NO, NZ, OM, PA, PE, PG, PH, PL, PT, QA, RO, RS, RU, RW, SA, SC, SD, SE, SG, SK, SL, SM, ST, SV, SY, TH, TJ, TM, TN, TR, TT, TZ, UA, UG, US, UZ, VC, VN, ZA, ZM, ZW.

- (84) **Designated States** (*unless otherwise indicated, for every kind of regional protection available*): ARIPO (BW, GH, GM, KE, LR, LS, MW, MZ, NA, RW, SD, SL, ST, SZ, TZ, UG, ZM, ZW), Eurasian (AM, AZ, BY, KG, KZ, RU, TJ, TM), European (AL, AT, BE, BG, CH, CY, CZ, DE, DK, EE, ES, FI, FR, GB, GR, HR, HU, IE, IS, IT, LT, LU, LV, MC, MK, MT, NL, NO, PL, PT, RO, RS, SE, SI, SK, SM, TR), OAPI (BF, BJ, CF, CG, CI, CM, GA, GN, GQ, GW, KM, ML, MR, NE, SN, TD, TG).

**Published:**  
— *with international search report (Art. 21(3))*

(54) **Title:** ENERGY MONITORING METHODS AND BATTERY DEVICES

**FIG 3**

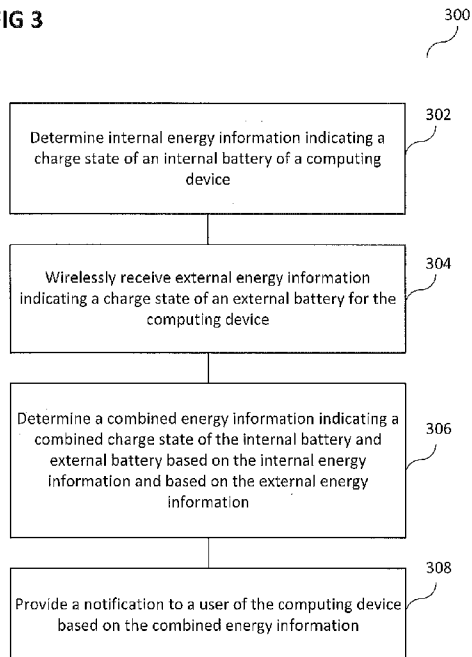

(57) **Abstract:** According to various embodiments, an energy monitoring method may be provided. The energy monitoring method may include: determining internal energy information indicating a charge state of an internal battery of a computing device; wirelessly receiving external energy information indicating a charge state of an external battery for the computing device; determining a combined energy information indicating a combined charge state of the internal battery and external battery based on the internal energy information and based on the external energy information; and providing a notification to a user of the computing device based on the combined energy information.

WO 2016/105273 A1

## ENERGY MONITORING METHODS AND BATTERY DEVICES

### Technical Field

[0001] Various embodiments generally relate to energy monitoring methods and battery devices.

### Background

[0002] Smart phones and other portable electronics devices frequently run out of battery. Thus, there may be a need for devices and methods which ensure that the smart phones or other portable electronics devices are provided with sufficient battery power.

### Summary of the Invention

[0003] According to various embodiments, an energy monitoring method may be provided. The energy monitoring method may include: determining internal energy information indicating a charge state of an internal battery of a computing device; wirelessly receiving external energy information indicating a charge state of an external battery for the computing device; determining a combined energy information indicating a combined charge state of the internal battery and external battery based on the internal energy information and based on the external energy information; and providing a notification to a user of the computing device based on the combined energy information.

[0004] According to various embodiments, a battery device may be provided. The battery device may include: a battery, wherein the battery is the external battery from which the external energy information is received wirelessly according in the energy monitoring method described above; and a wireless transmitter configured to wirelessly transmit the external energy information.

### Brief Description of the Drawings

[0005] In the drawings, like reference characters generally refer to the same parts throughout the different views. The drawings are not necessarily to scale, emphasis instead generally being placed upon illustrating the principles of the invention. The dimensions of the various features or elements may be arbitrarily expanded or reduced for clarity. In the following description, various embodiments of the invention are described with reference to the following drawings, in which:

[0006] FIG. 1 shows an energy monitoring device according to various embodiments;

[0007] FIG. 2 shows an energy monitoring device according to various embodiments;

[0008] FIG. 3 shows a flow diagram illustrating an energy monitoring method according to various embodiments;

[0009] FIG. 4 shows a battery device according to various embodiments;

[0010] FIG. 5 shows a battery device according to various embodiments; and

[0011] FIG. 6 shows a flow diagram illustrating a method for controlling a battery device according to various embodiments.

### **Detailed Description**

[0012] The following detailed description refers to the accompanying drawings that show, by way of illustration, specific details and embodiments in which the invention may be practiced. These embodiments are described in sufficient detail to enable those skilled in the art to practice the invention. Other embodiments may be utilized and structural, and logical changes may be made without departing from the scope of the invention. The various embodiments are not necessarily mutually exclusive, as some embodiments can be combined with one or more other embodiments to form new embodiments.

[0013] In this context, the energy monitoring device as described in this description may include a memory which is for example used in the processing carried out in the energy monitoring device. A memory used in the embodiments may be a volatile memory, for example a DRAM (Dynamic Random Access Memory) or a non-volatile

memory, for example a PROM (Programmable Read Only Memory), an EPROM (Erasable PROM), EEPROM (Electrically Erasable PROM), or a flash memory, e.g., a floating gate memory, a charge trapping memory, an MRAM (Magnetoresistive Random Access Memory) or a PCRAM (Phase Change Random Access Memory).

[0014] In an embodiment, a "circuit" may be understood as any kind of a logic implementing entity, which may be special purpose circuitry or a processor executing software stored in a memory, firmware, or any combination thereof. Thus, in an embodiment, a "circuit" may be a hard-wired logic circuit or a programmable logic circuit such as a programmable processor, e.g. a microprocessor (e.g. a Complex Instruction Set Computer (CISC) processor or a Reduced Instruction Set Computer (RISC) processor). A "circuit" may also be a processor executing software, e.g. any kind of computer program, e.g. a computer program using a virtual machine code such as e.g. Java. Any other kind of implementation of the respective functions which will be described in more detail below may also be understood as a "circuit" in accordance with an alternative embodiment.

[0015] In the specification the term "comprising" shall be understood to have a broad meaning similar to the term "including" and will be understood to imply the inclusion of a stated integer or step or group of integers or steps but not the exclusion of any other integer or step or group of integers or steps. This definition also applies to variations on the term "comprising" such as "comprise" and "comprises".

[0016] The reference to any prior art in this specification is not, and should not be taken as an acknowledgement or any form of suggestion that the referenced prior art forms part of the common general knowledge in Australia (or any other country).

[0017] In order that the invention may be readily understood and put into practical effect, particular embodiments will now be described by way of examples and not limitations, and with reference to the figures.

[0018] Various embodiments are provided for devices, and various embodiments are provided for methods. It will be understood that basic properties of the devices also hold for the methods and vice versa. Therefore, for sake of brevity, duplicate description of such properties may be omitted.

[0019] It will be understood that any property described herein for a specific device may also hold for any device described herein. It will be understood that any property described herein for a specific method may also hold for any method described herein. Furthermore, it will be understood that for any device or method described herein, not necessarily all the components or steps described must be enclosed in the device or method, but only some (but not all) components or steps may be enclosed.

[0020] The term “coupled” (or “connected”) herein may be understood as electrically coupled or as mechanically coupled, for example attached or fixed or attached, or just in contact without any fixation, and it will be understood that both direct coupling or indirect coupling (in other words: coupling without direct contact) may be provided.

[0021] Smart phones and other portable electronics devices frequently run out of battery. According to various embodiments, devices and methods may be provided which ensure that the smart phones or other portable electronics devices are provided with sufficient battery power.

[0022] While external battery packs (for example energy wearables) are being used, the user may often forget to charge them or may be unaware of the actual amount of charging required.

[0023] According to various embodiments, devices and methods may be provided for a dynamic power management of a portable battery pack and a mobile communication device. According to various embodiments, devices and methods may be provided for smart energy management of wearable devices.

[0024] FIG. 1 shows an energy monitoring device 100 according to various embodiments. The energy monitoring device 100 may include an internal energy determination circuit 102 configured to determine internal energy information indicating a charge state of an internal battery of a computing device. The energy monitoring device 100 may further include a wireless receiver 104 configured to wirelessly receive external energy information indicating a charge state of an external battery for the computing device. The energy monitoring device 100 may further include a combined charge determination circuit 106 configured to determine a combined energy information indicating a combined charge state of the internal battery and external battery based on

the internal energy information and based on the external energy information. The energy monitoring device 100 may further include a notification circuit 108 configured to provide a notification to a user of the computing device based on the combined energy information. The internal energy determination circuit 102, the wireless receiver 104, the combined charge determination circuit 106, and the notification circuit 108 may be coupled with each other, like indicated by lines 110, for example electrically coupled, for example using a line or a cable, and/ or mechanically coupled.

[0025] In other words, according to various embodiments, an energy monitoring device may be provided, which may notify a user of a computing device based on a total charge (or electric power) available in an internal battery of the computing device and an external battery (which may be external to the computing device).

[0026] FIG. 2 shows an energy monitoring device 200 according to various embodiments. The energy monitoring device 200 may, similar to the energy monitoring device 100 of FIG. 1, include an internal energy determination circuit 102 configured to determine internal energy information indicating a charge state of an internal battery of a computing device. The energy monitoring device 200 may, similar to the energy monitoring device 100 of FIG. 1, further include a wireless receiver 104 configured to wirelessly receive external energy information indicating a charge state of an external battery for the computing device. The energy monitoring device 200 may, similar to the energy monitoring device 100 of FIG. 1, further include a combined charge determination circuit 106 configured to determine a combined energy information indicating a combined charge state of the internal battery and external battery based on the internal energy information and based on the external energy information. The energy monitoring device 200 may, similar to the energy monitoring device 100 of FIG. 1, further include a notification circuit 108 configured to provide a notification to a user of the computing device based on the combined energy information. The energy monitoring device 200 may further include a remaining time determination circuit 202, like will be described in more detail below. The energy monitoring device 200 may further include a reserve setting circuit 204, like will be described in more detail below. The energy monitoring device 200 may further include a sufficiency determination circuit 206, like will be

described in more detail below. The energy monitoring device 200 may further include a standard charging start time determination circuit 208, like will be described in more detail below. The energy monitoring device 200 may further include a standard charging end time determination circuit 210, like will be described in more detail below. The energy monitoring device 200 may further include a daily usage intensity determination circuit 212, like will be described in more detail below. The internal energy determination circuit 102, the wireless receiver 104, the combined charge determination circuit 106, the notification circuit 108, the remaining time determination circuit 202, the reserve setting circuit 204, the sufficiency determination circuit 206, the standard charging start time determination circuit 208, the standard charging end time determination circuit 210, and the daily usage intensity determination circuit 212 may be coupled with each other, like indicated by lines 214, for example electrically coupled, for example using a line or a cable, and/ or mechanically coupled.

[0027] According to various embodiments, the remaining time determination circuit 202 may be configured to determine based on the combined energy a remaining time information indicating a remaining run time during which the internal battery and the external battery provide energy to the computing device.

[0028] According to various embodiments, the reserve setting circuit 204 may be configured to set a battery life reserve time indicating a desired duration for which the internal battery and the external battery are to provide energy to the computing device.

[0029] According to various embodiments, the sufficiency determination circuit 206 may be configured to determine whether the remaining run time is shorter than the desired duration.

[0030] According to various embodiments, the notification circuit 108 may further be configured to provide a warning notification to the user of the computing device if the sufficiency determination circuit determines that the remaining run time is shorter than the desired duration.

[0031] According to various embodiments, the standard charging start time determination circuit 208 may be configured to determine a daily time at which usually the user starts charging of at least one of the external battery or the internal battery.

[0032] According to various embodiments, the reserve setting circuit 204 may be configured to set, based on the daily time at which usually the user starts the charging, a battery life reserve time indicating a desired duration for which the internal battery and the external battery are to provide energy to the computing device.

[0033] According to various embodiments, the standard charging end time determination circuit 210 may be configured to determine a daily time at which usually the user ends charging of at least one of the external battery or the internal battery.

[0034] According to various embodiments, the reserve setting circuit 204 may be configured to set, based on the daily time at which usually the user ends the charging, a battery life reserve time indicating a desired duration for which the internal battery and the external battery are to provide energy to the computing device.

[0035] According to various embodiments, the daily usage intensity determination circuit 212 may be configured to determine a history of power consumption over pre-determined periods of a day.

[0036] According to various embodiments, the reserve setting circuit 204 may be configured to set, based on the history, a battery life reserve time indicating a desired duration for which the internal battery and the external battery are to provide energy to the computing device.

[0037] According to various embodiments, the external battery may be provided in a battery pack.

[0038] According to various embodiments, the energy monitoring device 200 may be provided in the computing device.

[0039] According to various embodiments, the computing device may be a smart phone.

[0040] According to various embodiments, the energy monitoring device 200 may be provided separate from the computing device. According to various embodiments, the wireless receiver 104 may further be configured to receive the internal energy information.

[0041] According to various embodiments, the energy monitoring device 200 may be a wearable device.



[0042] FIG. 3 shows a flow diagram 300 illustrating an energy monitoring method according to various embodiments. In 302, internal energy information indicating a charge state of an internal battery of a computing device may be determined. In 304, external energy information indicating a charge state of an external battery for the computing device may be received wirelessly. In 306, a combined energy information indicating a combined charge state of the internal battery and external battery may be determined based on the internal energy information and based on the external energy information. In 308, a notification may be provided to a user of the computing device based on the combined energy information.

[0043] According to various embodiments, energy monitoring method may further include determining based on the combined energy a remaining time information indicating a remaining run time during which the internal battery and the external battery provide energy to the computing device.

[0044] According to various embodiments, energy monitoring method may further include setting a battery life reserve time indicating a desired duration for which the internal battery and the external battery are to provide energy to the computing device.

[0045] According to various embodiments, energy monitoring method may further include determining whether the remaining run time is shorter than the desired duration.

[0046] According to various embodiments, energy monitoring method may further include providing a warning notification to the user of the computing device if the sufficiency determination circuit determines that the remaining run time is shorter than the desired duration.

[0047] According to various embodiments, energy monitoring method may further include determining a daily time at which usually the user starts charging of at least one of the external battery or the internal battery.

[0048] According to various embodiments, energy monitoring method may further include setting, based on the daily time at which usually the user starts the charging, a battery life reserve time indicating a desired duration for which the internal battery and the external battery are to provide energy to the computing device.

[0049] According to various embodiments, energy monitoring method may further include determining a daily time at which usually the user ends charging of at least one of the external battery or the internal battery.

[0050] According to various embodiments, energy monitoring method may further include determining a history of power consumption over pre-determined periods of a day.

[0051] According to various embodiments, energy monitoring method may further include setting, based on the history, a battery life reserve time indicating a desired duration for which the internal battery and the external battery are to provide energy to the computing device.

[0052] According to various embodiments, the external battery may be provided in a battery pack.

[0053] According to various embodiments, the energy monitoring method may be carried out in the computing device.

[0054] According to various embodiments, the computing device may be a smart phone.

[0055] According to various embodiments, the energy monitoring method may be carried out in a device separate from the computing device.

[0056] According to various embodiments, the energy monitoring method may be carried out in a wearable device.

[0057] According to various embodiments, a battery device may be provided. The battery device may include: a battery, wherein the battery is the external battery from which the external energy information is received wirelessly in an energy monitoring method (for example the energy monitoring method like described above with reference to FIG. 3); and a wireless transmitter configured to wirelessly transmit the external energy information.

[0058] FIG. 4 shows a battery device 400 according to various embodiments. The battery device 400 may include a battery 402. The battery device 400 may further include a wireless transmitter 404 configured to wirelessly transmit external energy information indicating a charge state of the battery 402 to a computing device (not shown in FIG. 4).

The battery device 400 may further include a power connector 406 configured to provide energy from the battery 402 to the computing device. The battery 402, the wireless transmitter 404, and the power connector 406 may be coupled with each other, like indicated by lines 408, for example electrically coupled, for example using a line or a cable, and/ or mechanically coupled.

[0059] FIG. 5 shows a battery device 500 according to various embodiments. The battery device 500 may, similar to the battery device 400 described above with reference to FIG. 4, include a battery 402. The battery device 500 may, similar to the battery device 400 described above with reference to FIG. 4, further include a wireless transmitter 404 configured to wirelessly transmit external energy information indicating a charge state of the battery 402 to a computing device (not shown in FIG. 5). The battery device 500 may, similar to the battery device 400 described above with reference to FIG. 4, may further include a power connector 406 configured to provide energy from the battery 402 to the computing device. The battery device 500 may further include a remaining time determination circuit 502, like will be described in more detail below. The battery device 500 may further include a reserve setting circuit 504, like will be described in more detail below. The battery device 500 may further include a sufficiency determination circuit 506, like will be described in more detail below. The battery device 500 may further include a notification circuit 508, like will be described in more detail below. The battery device 500 may further include a standard charging start time determination circuit 510, like will be described in more detail below. The battery device 500 may further include a standard charging end time determination circuit 510, like will be described in more detail below. The battery device 500 may further include a daily usage intensity determination circuit 514, like will be described in more detail below. The battery 402, the wireless transmitter 404, the power connector 406, the remaining time determination circuit 502, the reserve setting circuit 504, the sufficiency determination circuit 506, the notification circuit 508, the standard charging start time determination circuit 510, the standard charging end time determination circuit 510, and the daily usage intensity determination circuit 514 may be coupled with each other, like indicated by lines 516, for

example electrically coupled, for example using a line or a cable, and/ or mechanically coupled.

[0060] According to various embodiments, the remaining time determination circuit 502 may be configured to determine a remaining time information indicating a remaining run time during which the battery 402 provides energy to the computing device.

[0061] According to various embodiments, the reserve setting circuit 504 may be configured to set a battery life reserve time indicating a desired duration for which the battery 402 is to provide energy to the computing device.

[0062] According to various embodiments, the sufficiency determination circuit 506 may be configured to determine whether the remaining run time is shorter than the desired duration.

[0063] According to various embodiments, the notification circuit 508 may be to provide (for example via a wireless transmission to the computing device) a warning notification to the user of the computing device if the sufficiency determination circuit determines that the remaining run time is shorter than the desired duration.

[0064] According to various embodiments, the standard charging start time determination circuit 510 may be configured to determine a daily time at which usually the user starts charging of the battery 402.

[0065] According to various embodiments, the reserve setting circuit 504 may be configured to set, based on the daily time at which usually the user starts the charging, a battery life reserve time indicating a desired duration for which the battery 402 is to provide energy to the computing device.

[0066] According to various embodiments, the standard charging end time determination circuit 512 may be configured to determine a daily time at which usually the user ends charging of battery 402.

[0067] According to various embodiments, the daily usage intensity determination circuit 514 may be configured to determine a history of power consumption over pre-determined periods of a day.

[0068] According to various embodiments, the reserve setting circuit 504 may be configured to set, based on the history, a battery life reserve time indicating a desired duration for which the battery 402 is to provide energy to the computing device.

[0069] According to various embodiments, the battery device may be provided separate from the computing device.

[0070] According to various embodiments, the power connector may include a universal serial bus connector.

[0071] FIG. 6 shows a flow diagram 600 illustrating a method for controlling a battery device according to various embodiments. In 602, a battery may be controlled. In 604, external energy information indicating a charge state of the battery may be wirelessly transmitted to a computing device. In 606, energy may be provided from the battery to the computing device.

[0072] According to various embodiments, a computer-readable medium may be provided. The computer-readable medium may include program instructions which when executed by a processor cause the processor to perform an energy monitoring, for example the energy monitoring method like described above with reference to FIG. 3.

[0073] According to various embodiments, a server may be provided. The server may include a downloadable program which includes program instructions which when downloaded and executed by a processor cause the processor to perform an energy monitoring, for example the energy monitoring method like described above with reference to FIG. 3.

[0074] According to various embodiments, a downloadable application (in other words: an app) may be provided which may perform an energy monitoring, for example the energy monitoring method like described above with reference to FIG. 3

[0075] According to various embodiments, devices and methods of dynamically monitoring battery life in a portable battery pack/energy wearables and a mobile communication device may be provided. For example, the method may include the following steps:

[0076] 1) Receiving battery life data wirelessly from an external battery pack (or energy wearable);

- [0077] 2) Monitoring existing battery life of a smartphone battery in real time;
- [0078] 3) Calculating battery drawdown of smartphone battery;
- [0079] 4) Setting a predefined smartphone battery life reserve in number of hours;
- [0080] 5) Determining if the combined existing smartphone battery life and battery life data of external battery pack is less than predefined smartphone battery life; and
- [0081] 6) Alerting the user of the smartphone battery life status when 5) occurs.

[0082] According to various embodiments, a dynamic monitoring method or a dynamic monitoring device or a dynamic monitoring application (or app) may be provided which may be wirelessly linked to the smartphone and the external battery pack/wearable.

[0083] According to various embodiments, the smartphone may have an energy monitoring device or an energy monitoring app installed.

[0084] According to various embodiments, an external battery pack may be able to know the amount of battery life it has and may be able to provide the data.

[0085] According to various embodiments, the energy monitoring device or energy monitoring app may be linked to the external battery pack wirelessly.

[0086] According to various embodiments, the energy monitoring device or energy monitoring app may have information of the existing battery power on the smartphone as well as on the external battery pack.

[0087] According to various embodiments, the energy monitoring device or energy monitoring app may be able to calculate the amount of battery draw by the smart phone.

[0088] According to various embodiments, the energy monitoring device or energy monitoring app may be pre-defined to always provide for a pre-determined amount of time (for example "x" hours, where x may be a pre-determined number) of battery life for the smartphone. For example, the energy monitoring device or energy monitoring app may calculate the amount of battery required for the pre-determined period of time (for example x hours) for the smart phone and may combine available battery life for both the smartphone and the external battery pack to alert the user if the predefined hours of battery life falls below the requirement. For example, the user can state: "Always have at least 8 hours of battery life"; then, if the combined battery life of the smart phone and the

external battery pack goes lower than 8 hours, the user may be alerted via the energy monitoring device or app.

[0089] According to various embodiments, the energy monitoring device or energy monitoring app may learn the charging patterns of the user. For example, the user may usually charge its smart phone and/ or battery back at pre-determined points of time (for example every night at 10pm) and goes off charging at other pre-determined points of time (for example 9am in the morning). The energy monitoring device or energy monitoring app may alert the user if the combined battery life of the smartphone and external battery pack falls below the usual pattern. For example, the average time that the user charges his phone for the past 7 days may be at 10pm and the average time the user takes the phone off charging is at 9am and the phone knows it needs to have a total battery life of 9am to 10pm for the phone and battery pack combined. The energy monitoring device or app may alert the user when he is likely to run out of battery or if he needs to charge his external battery pack or both.

[0090] According to various embodiments, external battery packs for mobile communication or computing devices or energy wearables which may be wearable devices that act as external battery packs for mobile communication or computing devices may be provided.

[0091] According to various embodiments, devices and/ or methods and/ or software and/or applications (in other words: apps) may be provided.

[0092] It will be understood that although some embodiments are described with respect to a mobile phone (or smart phone), energy management according to various embodiments is not limited to mobile phones or smart phones, but may be provided for any kind of device which needs battery power.

[0093] The following examples pertain to further embodiments.

[0094] Example 1 is an energy monitoring method comprising: determining internal energy information indicating a charge state of an internal battery of a computing device; wirelessly receiving external energy information indicating a charge state of an external battery for the computing device; determining a combined energy information indicating a combined charge state of the internal battery and external battery based on the internal

energy information and based on the external energy information; and providing a notification to a user of the computing device based on the combined energy information.

[0095] In example 2, the subject-matter of example 1 can optionally include determining based on the combined energy a remaining time information indicating a remaining run time during which the internal battery and the external battery provide energy to the computing device.

[0096] In example 3, the subject-matter of example 2 can optionally include setting a battery life reserve time indicating a desired duration for which the internal battery and the external battery are to provide energy to the computing device.

[0097] In example 4, the subject-matter of example 3 can optionally include determining whether the remaining run time is shorter than the desired duration.

[0098] In example 5, the subject-matter of example 4 can optionally include providing a warning notification to the user of the computing device if the sufficiency determination circuit determines that the remaining run time is shorter than the desired duration.

[0099] In example 6, the subject-matter of any one of examples 1 to 5 can optionally include determining a daily time at which usually the user starts charging of at least one of the external battery or the internal battery.

[00100] In example 7, the subject-matter of example 6 can optionally include setting, based on the daily time at which usually the user starts the charging, a battery life reserve time indicating a desired duration for which the internal battery and the external battery are to provide energy to the computing device.

[00101] In example 8, the subject-matter of any one of examples 1 to 7 can optionally include determining a daily time at which usually the user ends charging of at least one of the external battery or the internal battery.

[00102] In example 9, the subject-matter of any one of examples 1 to 8 can optionally include determining a history of power consumption over pre-determined periods of a day.



[00103] In example 10, the subject-matter of example 9 can optionally include setting, based on the history, a battery life reserve time indicating a desired duration for which the internal battery and the external battery are to provide energy to the computing device.

[00104] In example 11, the subject-matter of any one of examples 1 to 10 can optionally include that the external battery is provided in a battery pack.

[00105] In example 12, the subject-matter of any one of examples 1 to 11 can optionally include that the energy monitoring method is carried out in the computing device.

[00106] In example 13, the subject-matter of any one of examples 1 to 12 can optionally include that the computing device is a smart phone.

[00107] In example 14, the subject-matter of any one of examples 1 to 13 can optionally include that the energy monitoring method is carried out in a device separate from the computing device.

[00108] In example 15, the subject-matter of any one of examples 1 to 14 can optionally include that the energy monitoring method is carried out in a wearable device.

[00109] Example 16 is a battery device comprising: a battery, wherein the battery is the external battery from which the external energy information is received wirelessly in the energy monitoring method according to any one of examples 1 to 15; and a wireless transmitter configured to wirelessly transmit the external energy information.

[00110] Example 17 is a battery device comprising: a battery; a wireless transmitter configured to wirelessly transmit external energy information indicating a charge state of the battery to a computing device; and a power connector configured to provide energy from the battery to the computing device.

[00111] In example 18, the subject-matter of example 17 can optionally include a remaining time determination circuit configured to determine a remaining time information indicating a remaining run time during which the battery provides energy to the computing device.

[00112] In example 19, the subject-matter of example 18 can optionally include a reserve setting circuit configured to set a battery life reserve time indicating a desired duration for which the battery is to provide energy to the computing device.

[00113] In example 20, the subject-matter of example 19 can optionally include a sufficiency determination circuit configured to determine whether the remaining run time is shorter than the desired duration.

[00114] In example 21, the subject-matter of example 20 can optionally include a notification circuit configured to provide a warning notification to the user of the computing device if the sufficiency determination circuit determines that the remaining run time is shorter than the desired duration.

[00115] In example 22, the subject-matter of any one of examples 17 to 21 can optionally include a standard charging start time determination circuit configured to determine a daily time at which usually the user starts charging of the battery.

[00116] In example 23, the subject-matter of example 22 can optionally include a reserve setting circuit configured to set, based on the daily time at which usually the user starts the charging, a battery life reserve time indicating a desired duration for which the battery is to provide energy to the computing device.

[00117] In example 24, the subject-matter of any one of examples 17 to 23 can optionally include a standard charging end time determination circuit configured to determine a daily time at which usually the user ends charging of battery.

[00118] In example 25, the subject-matter of any one of examples 17 to 24 can optionally include a daily usage intensity determination circuit configured to determine a history of power consumption over pre-determined periods of a day.

[00119] In example 26, the subject-matter of example 25 can optionally include a reserve setting circuit configured to set, based on the history, a battery life reserve time indicating a desired duration for which the battery is to provide energy to the computing device.

[00120] In example 27, the subject-matter of any one of examples 17 to 26 can optionally include that the battery device is provided separate from the computing device.

[00121] In example 28, the subject-matter of any one of examples 17 to 27 can optionally include that the power connector comprises a universal serial bus connector.

[00122] Example 29 is a computer-readable medium comprising program instructions which when executed by a processor cause the processor to perform the energy monitoring method of any one of examples 1 to 15.

[00123] Example 30 is a server comprising a downloadable program which comprises program instructions which when downloaded and executed by a processor cause the processor to perform the energy monitoring method of any one of examples 1 to 15.

[00124] While the invention has been particularly shown and described with reference to specific embodiments, it should be understood by those skilled in the art that various changes in form and detail may be made therein without departing from the spirit and scope of the invention as defined by the appended claims. The scope of the invention is thus indicated by the appended claims and all changes which come within the meaning and range of equivalency of the claims are therefore intended to be embraced.

**CLAIMS**

1. An energy monitoring method comprising:
  - determining internal energy information indicating a charge state of an internal battery of a computing device;
  - wirelessly receiving external energy information indicating a charge state of an external battery for the computing device;
  - determining a combined energy information indicating a combined charge state of the internal battery and external battery based on the internal energy information and based on the external energy information; and
  - providing a notification to a user of the computing device based on the combined energy information.
  
2. The energy monitoring method of claim 1, further comprising:
  - determining based on the combined energy a remaining time information indicating a remaining run time during which the internal battery and the external battery provide energy to the computing device.
  
3. The energy monitoring method of claim 2, further comprising:
  - setting a battery life reserve time indicating a desired duration for which the internal battery and the external battery are to provide energy to the computing device.
  
4. The energy monitoring method of claim 3, further comprising:
  - determining whether the remaining run time is shorter than the desired duration.
  
5. The energy monitoring method of claim 4, further comprising:
  - providing a warning notification to the user of the computing device if the sufficiency determination circuit determines that the remaining run time is shorter than the desired duration.

6. The energy monitoring method of claim 1, further comprising:  
determining a daily time at which usually the user starts charging of at least one of the external battery or the internal battery.
7. The energy monitoring method of claim 6, further comprising:  
setting, based on the daily time at which usually the user starts the charging, a battery life reserve time indicating a desired duration for which the internal battery and the external battery are to provide energy to the computing device.
8. The energy monitoring method of claim 1, further comprising:  
determining a daily time at which usually the user ends charging of at least one of the external battery or the internal battery.
9. The energy monitoring method of claim 1, further comprising:  
determining a history of power consumption over pre-determined periods of a day.
10. The energy monitoring method of claim 9, further comprising:  
setting, based on the history, a battery life reserve time indicating a desired duration for which the internal battery and the external battery are to provide energy to the computing device.
11. The energy monitoring method of claim 1,  
wherein the external battery is provided in a battery pack.
12. The energy monitoring method of claim 1,  
wherein the energy monitoring method is carried out in the computing device.
13. The energy monitoring method of claim 1,

wherein the computing device is a smart phone.

14. The energy monitoring method of claim 1,  
wherein the energy monitoring method is carried out in a device separate from the computing device.

15. The energy monitoring method of claim 1,  
wherein the energy monitoring method is carried out in a wearable device.

16. A battery device comprising:  
a battery, wherein the battery is the external battery from which the external energy information is received wirelessly in the energy monitoring method according to claim 1; and  
a wireless transmitter configured to wirelessly transmit the external energy information.

17. A battery device comprising:  
a battery;  
a wireless transmitter configured to wirelessly transmit external energy information indicating a charge state of the battery to a computing device; and  
a power connector configured to provide energy from the battery to the computing device.

18. The battery device of claim 17, further comprising:  
a remaining time determination circuit configured to determine a remaining time information indicating a remaining run time during which the battery provides energy to the computing device.

19. The battery device of claim 18, further comprising:

a reserve setting circuit configured to set a battery life reserve time indicating a desired duration for which the battery is to provide energy to the computing device.

20. The battery device of claim 19, further comprising:  
a sufficiency determination circuit configured to determine whether the remaining run time is shorter than the desired duration.

21. The battery device of claim 20, further comprising:  
a notification circuit configured to provide a warning notification to the user of the computing device if the sufficiency determination circuit determines that the remaining run time is shorter than the desired duration.

22. The battery device of claim 17, further comprising:  
a standard charging start time determination circuit configured to determine a daily time at which usually the user starts charging of the battery.

23. The battery device of claim 22, further comprising:  
a reserve setting circuit configured to set, based on the daily time at which usually the user starts the charging, a battery life reserve time indicating a desired duration for which the battery is to provide energy to the computing device.

24. The battery device of claim 17, further comprising:  
a standard charging end time determination circuit configured to determine a daily time at which usually the user ends charging of battery.

25. The battery device of claim 17, further comprising:  
a daily usage intensity determination circuit configured to determine a history of power consumption over pre-determined periods of a day.

26. The battery device of claim 25, further comprising:

a reserve setting circuit configured to set, based on the history, a battery life reserve time indicating a desired duration for which the battery is to provide energy to the computing device.

27. The battery device of claim 17,  
wherein the battery device is provided separate from the computing device.
28. The battery device of claim 17,  
wherein the power connector comprises a universal serial bus connector.
29. A computer-readable medium comprising program instructions which when executed by a processor cause the processor to perform the energy monitoring method of claim 1.
30. A server comprising a downloadable program which comprises program instructions which when downloaded and executed by a processor cause the processor to perform the energy monitoring method of claim 1.



**FIG 1**

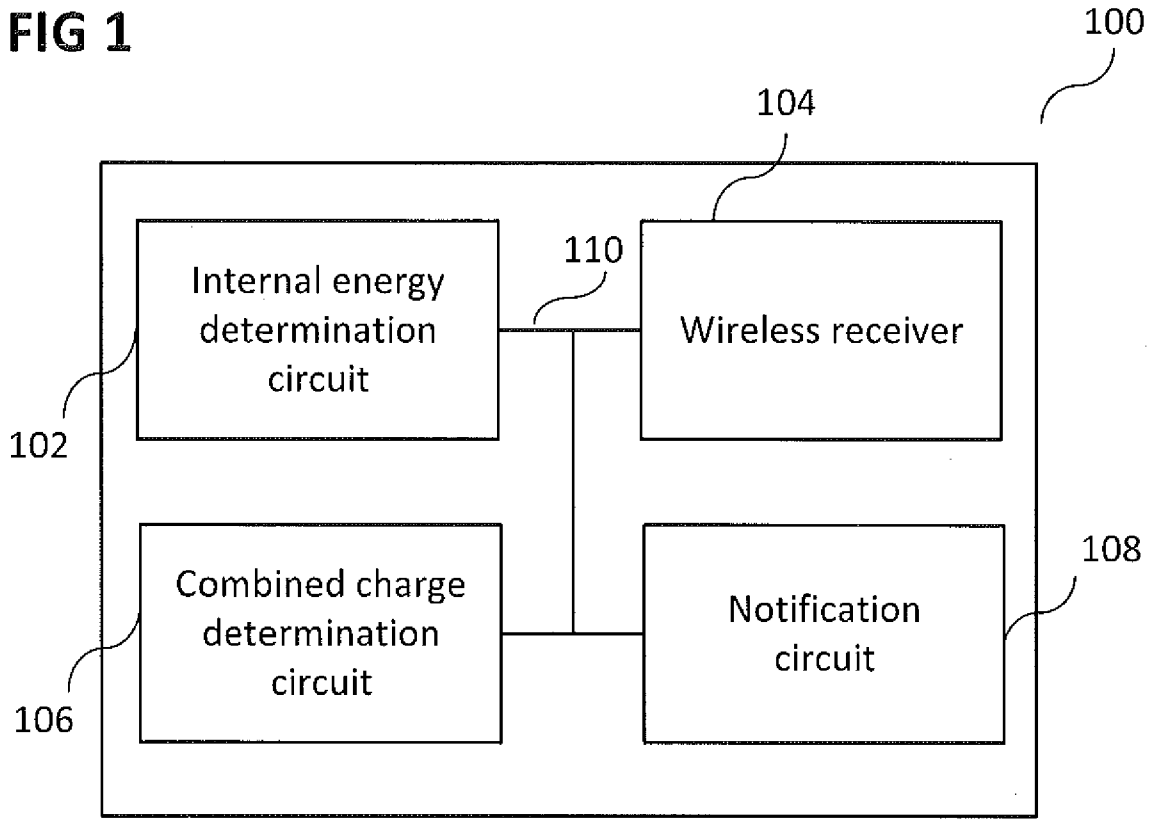

**FIG 4**

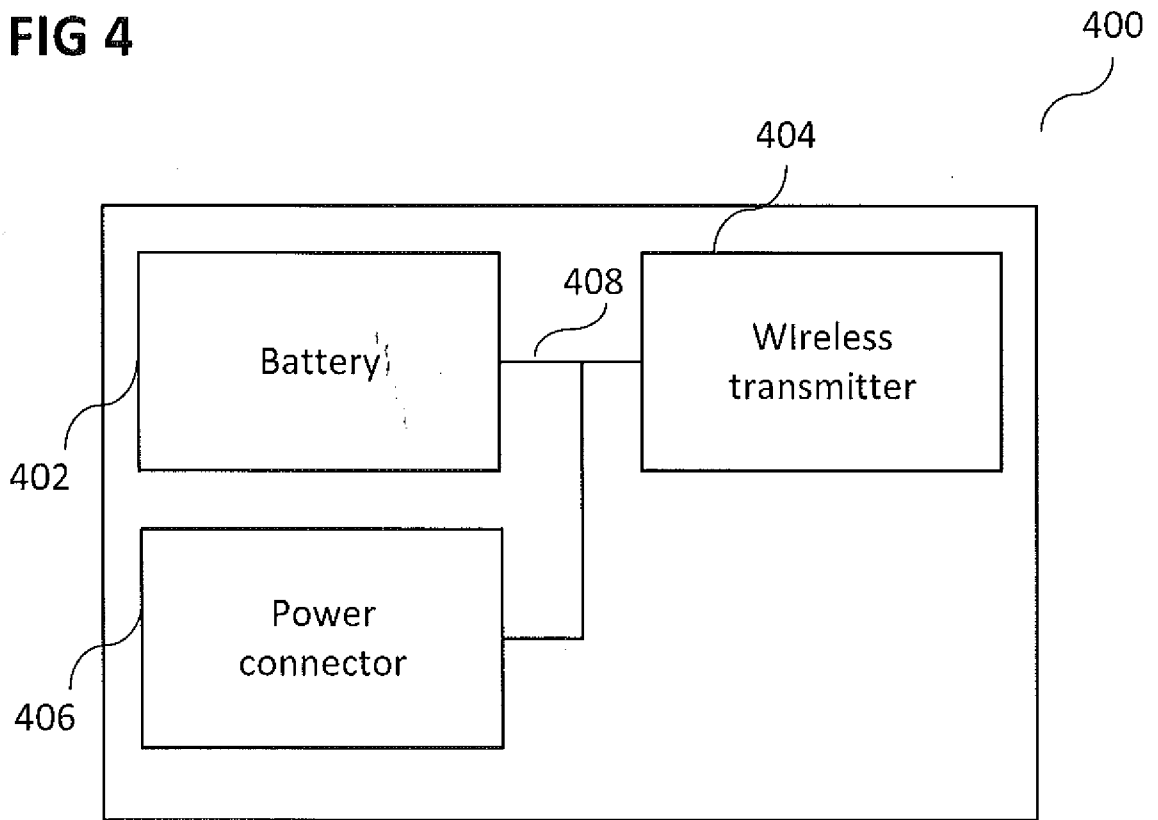

FIG 2

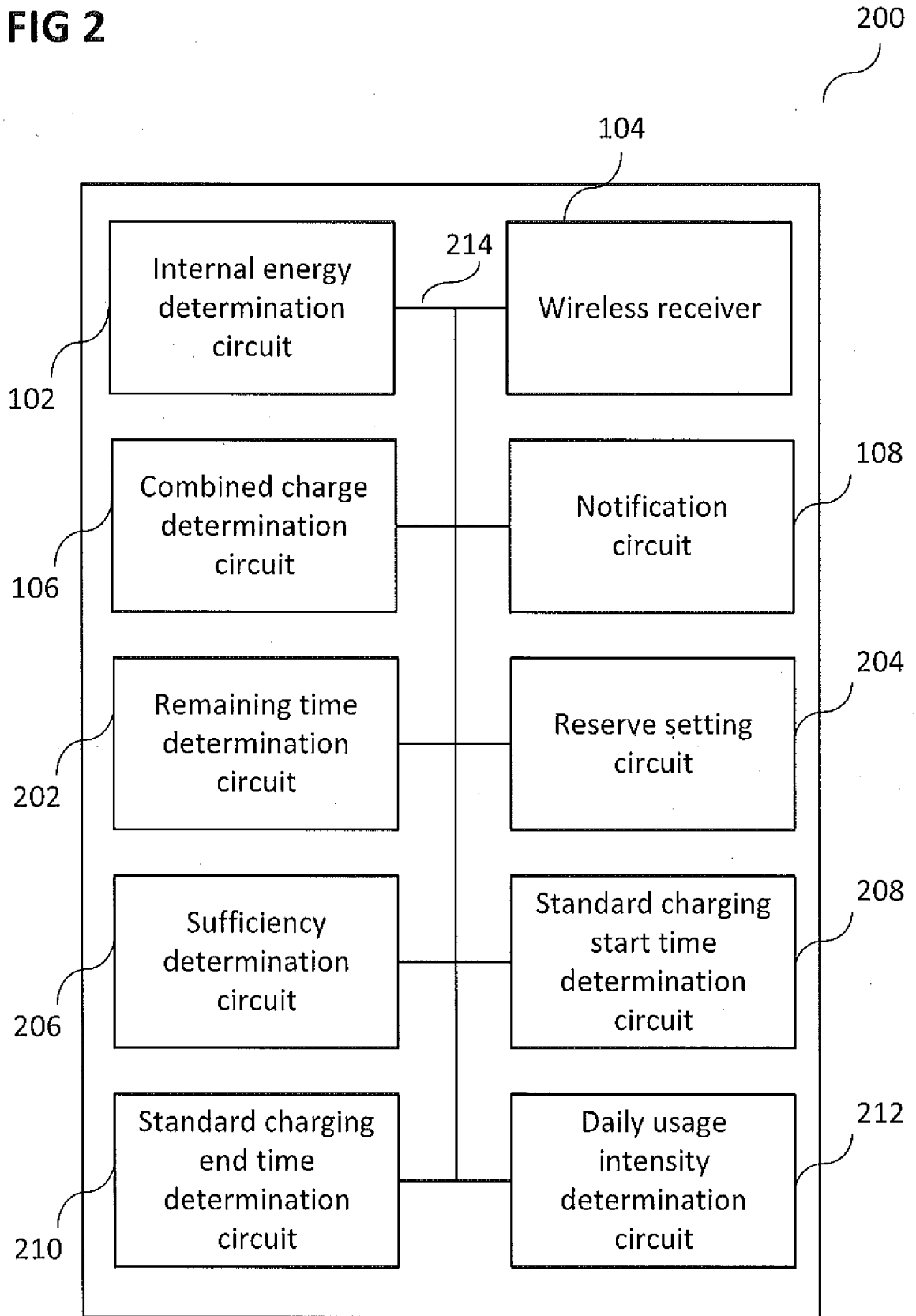

FIG 3

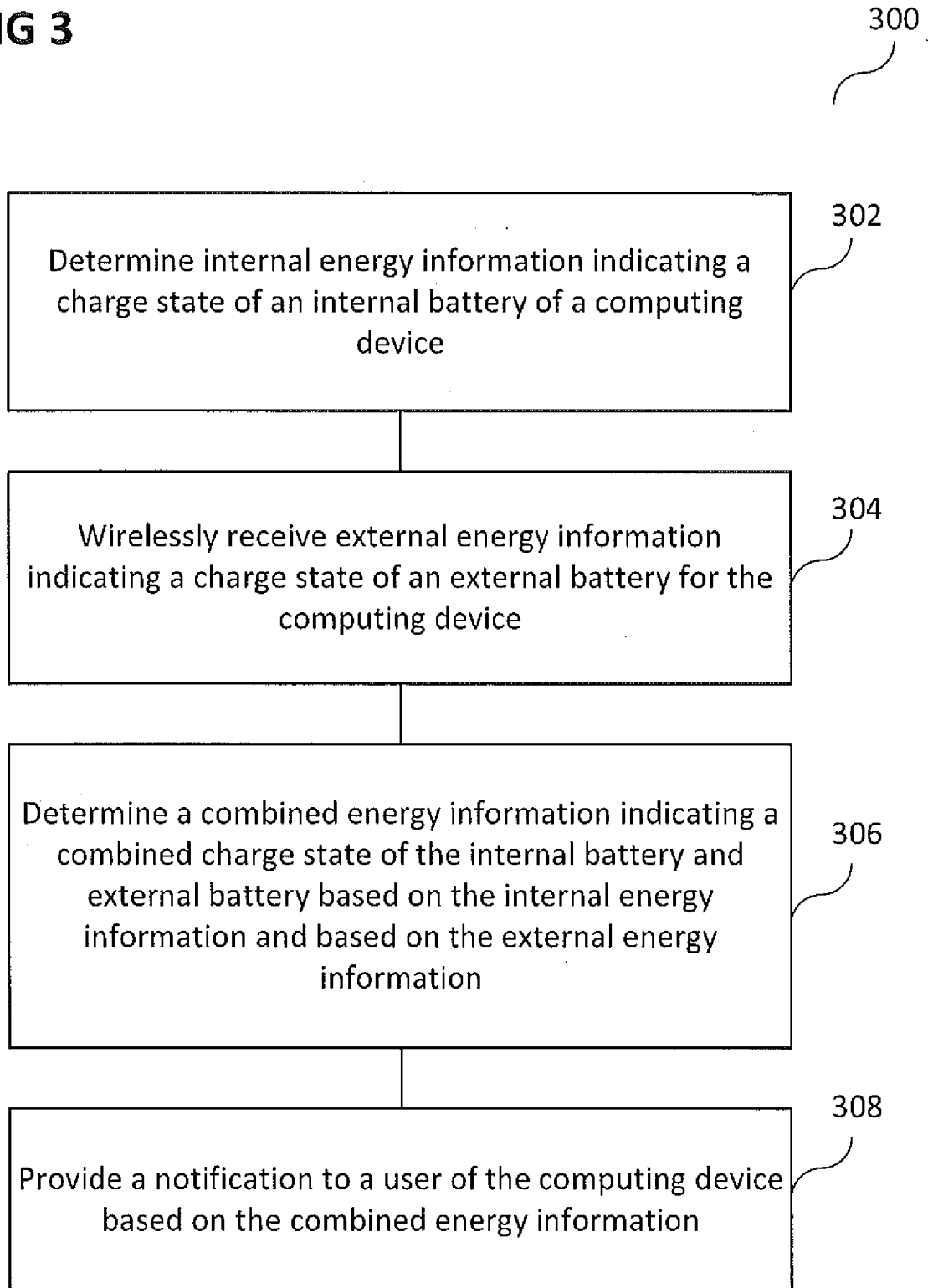
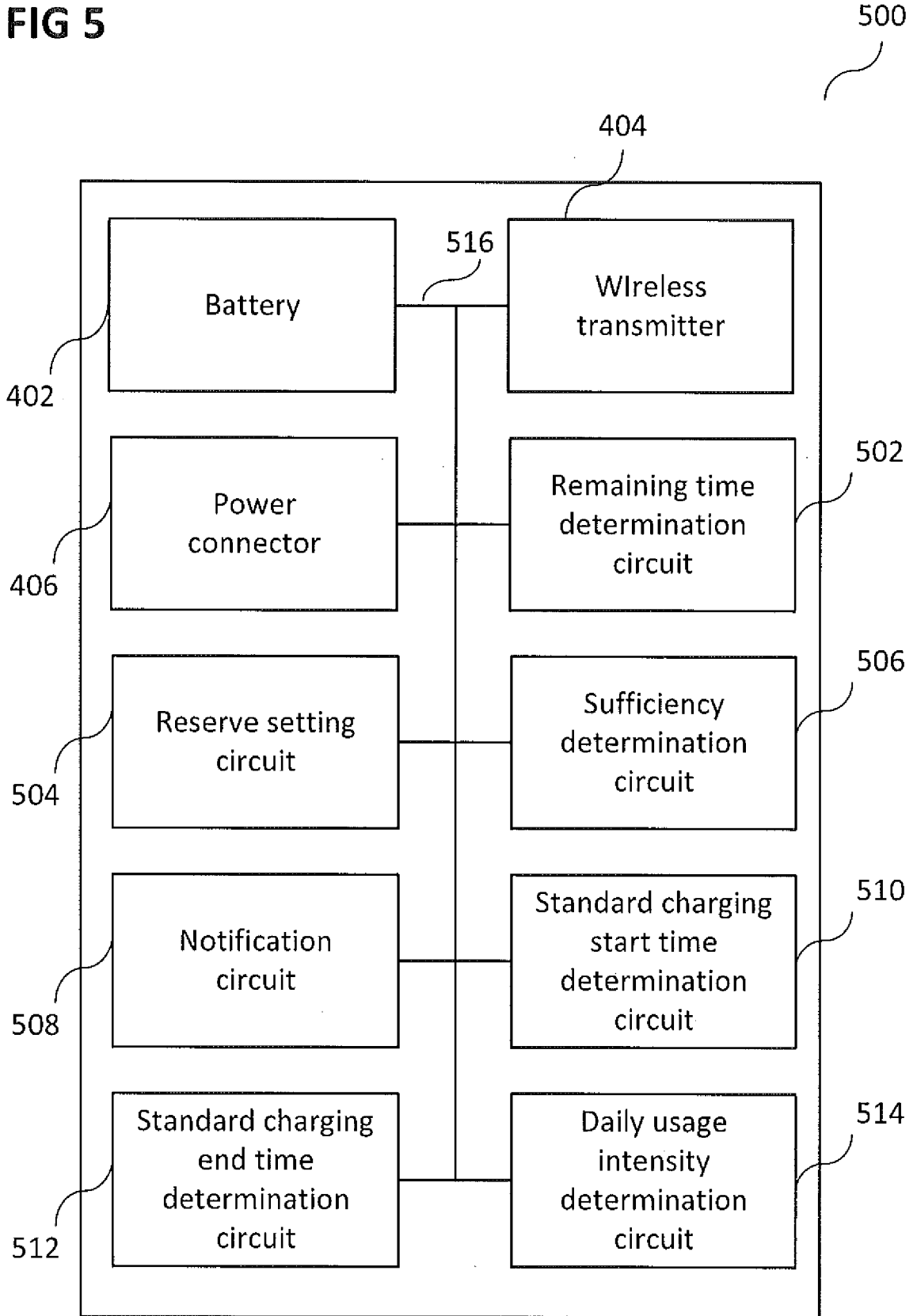
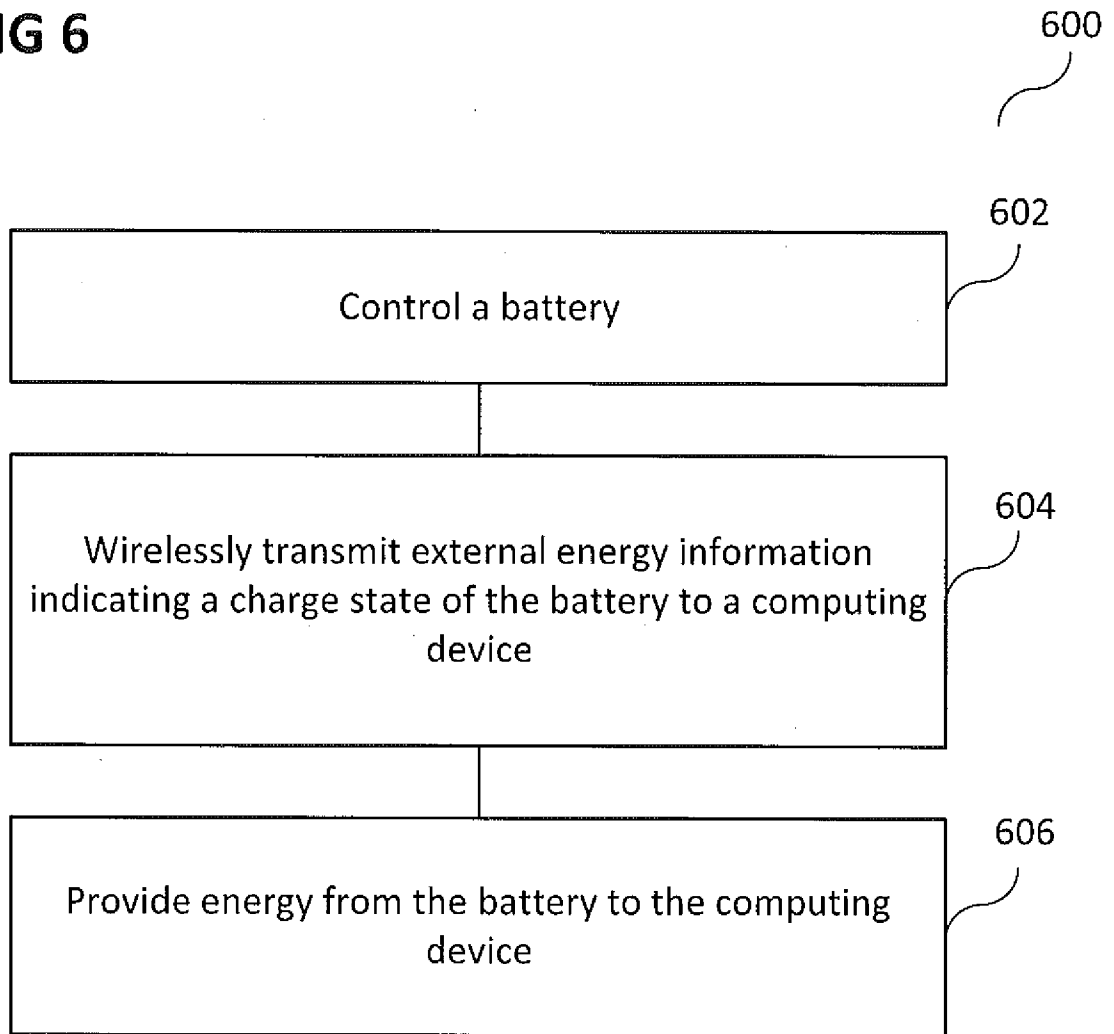

FIG 5



**FIG 6**



**A. CLASSIFICATION OF SUBJECT MATTER****G01R 31/36(2006.01)i, H01M 10/48(2006.01)i**

According to International Patent Classification (IPC) or to both national classification and IPC

**B. FIELDS SEARCHED**Minimum documentation searched (classification system followed by classification symbols)  
G01R 31/36; G08B 1/08; H02J 7/00; H04B 1/38; H04M 1/72; G01N 27/416; H01M 10/48Documentation searched other than minimum documentation to the extent that such documents are included in the fields searched  
Korean utility models and applications for utility models  
Japanese utility models and applications for utility modelsElectronic data base consulted during the international search (name of data base and, where practicable, search terms used)  
eKOMPASS(KIPO internal) & keywords: battery, monitor, internal, external, life**C. DOCUMENTS CONSIDERED TO BE RELEVANT**

Category*	Citation of document, with indication, where appropriate, of the relevant passages	Relevant to claim No.
Y	WO 99-43095 A1 (QUALCOMM INCORPORATED) 26 August 1999 See abstract, pages 3-11, claims 1-4 and figures 1-3.	1-30
Y	US 2014-0229129 A1 (JOHNSON CONTROLS TECHNOLOGY COMPANY) 14 August 2014 See abstract, paragraphs [0022]-[0034], claims 1-8 and figures 2-4.	1-30
A	US 6249124 B1 (BERTNESS) 19 June 2001 See abstract, claims 1-19 and figures 1-5.	1-30
A	US 2007-0001680 A1 (KHOO) 04 January 2007 See abstract, claims 1-16 and figures 1-7.	1-30
A	US 2006-0250233 A1 (POWELL et al.) 09 November 2006 See figures 1-4.	1-30

 Further documents are listed in the continuation of Box C. See patent family annex.

\* Special categories of cited documents:

"A" document defining the general state of the art which is not considered to be of particular relevance

"E" earlier application or patent but published on or after the international filing date

"L" document which may throw doubts on priority claim(s) or which is cited to establish the publication date of another citation or other special reason (as specified)

"O" document referring to an oral disclosure, use, exhibition or other means

"P" document published prior to the international filing date but later than the priority date claimed

"T" later document published after the international filing date or priority date and not in conflict with the application but cited to understand the principle or theory underlying the invention

"X" document of particular relevance; the claimed invention cannot be considered novel or cannot be considered to involve an inventive step when the document is taken alone

"Y" document of particular relevance; the claimed invention cannot be considered to involve an inventive step when the document is combined with one or more other such documents, such combination being obvious to a person skilled in the art

"&amp;" document member of the same patent family

Date of the actual completion of the international search

26 August 2015 (26.08.2015)

Date of mailing of the international search report

**27 August 2015 (27.08.2015)**

Name and mailing address of the ISA/KR

 International Application Division  
 Korean Intellectual Property Office  
 189 Cheongsu-ro, Seo-gu, Daejeon Metropolitan City, 35208,  
 Republic of Korea

Facsimile No. +82-42-472-7140

Authorized officer

KANG, Sung Chul

Telephone No. +82-42-481-8405



**INTERNATIONAL SEARCH REPORT**

Information on patent family members

International application No.

**PCT/SG2014/000612**

Patent document cited in search report	Publication date	Patent family member(s)	Publication date
WO 99-43095 A1	26/08/1999	AR 014635 A1	28/03/2001
		AU 1999-33072 A1	06/09/1999
		AU 1999-33072 B2	16/05/2002
		AU 1999-48597 A1	24/01/2000
		AU 1999-48597 B2	08/05/2003
		AU 3307299 A	06/09/1999
		AU 747458 B2	16/05/2002
		BR 9908052 A	11/06/2002
		CA 2321212 A1	26/08/1999
		CA 2336858 A1	13/01/2000
		CN 1316125 A	03/10/2001
		EP 1057275 A1	06/12/2000
		EP 1095439 A1	02/05/2001
		ID 27309 A	22/03/2001
		JP 2002-504800 A	12/02/2002
		JP 2002-520989 A	09/07/2002
		KR 10-2001-0041160 A	15/05/2001
		KR 10-2001-0071761 A	31/07/2001
		RU 2204204 C2	10/05/2003
		US 06118250 A	12/09/2000
		US 06167289 A	26/12/2000
WO 00-02299 A1	13/01/2000		
US 2014-0229129 A1	14/08/2014	WO 2014-126685 A1	21/08/2014
US 6249124 B1	19/06/2001	None	
US 2007-0001680 A1	04/01/2007	AU 2004-205978 A1	05/08/2004
		CA 2513877 A1	05/08/2004
		EP 1588439 A2	26/10/2005
		GB 0301342 D0	19/02/2003
		GB 2397656 A	28/07/2004
		WO 2004-066413 A2	05/08/2004
		WO 2004-066413 A3	02/12/2004
ZA 200506997 A	30/08/2006		
US 2006-0250233 A1	09/11/2006	GB 0605012 D0	19/04/2006
		GB 2424318 A8	23/12/2009
		GB 2424318 B	16/09/2009
		US 7598880 B2	06/10/2009