

G. W. WHITEMAN & H. R. LEONARD,

TIE PLATE.

APPLICATION FILED JAN. 6, 1909.

916,904.

Patented Mar. 30, 1909.

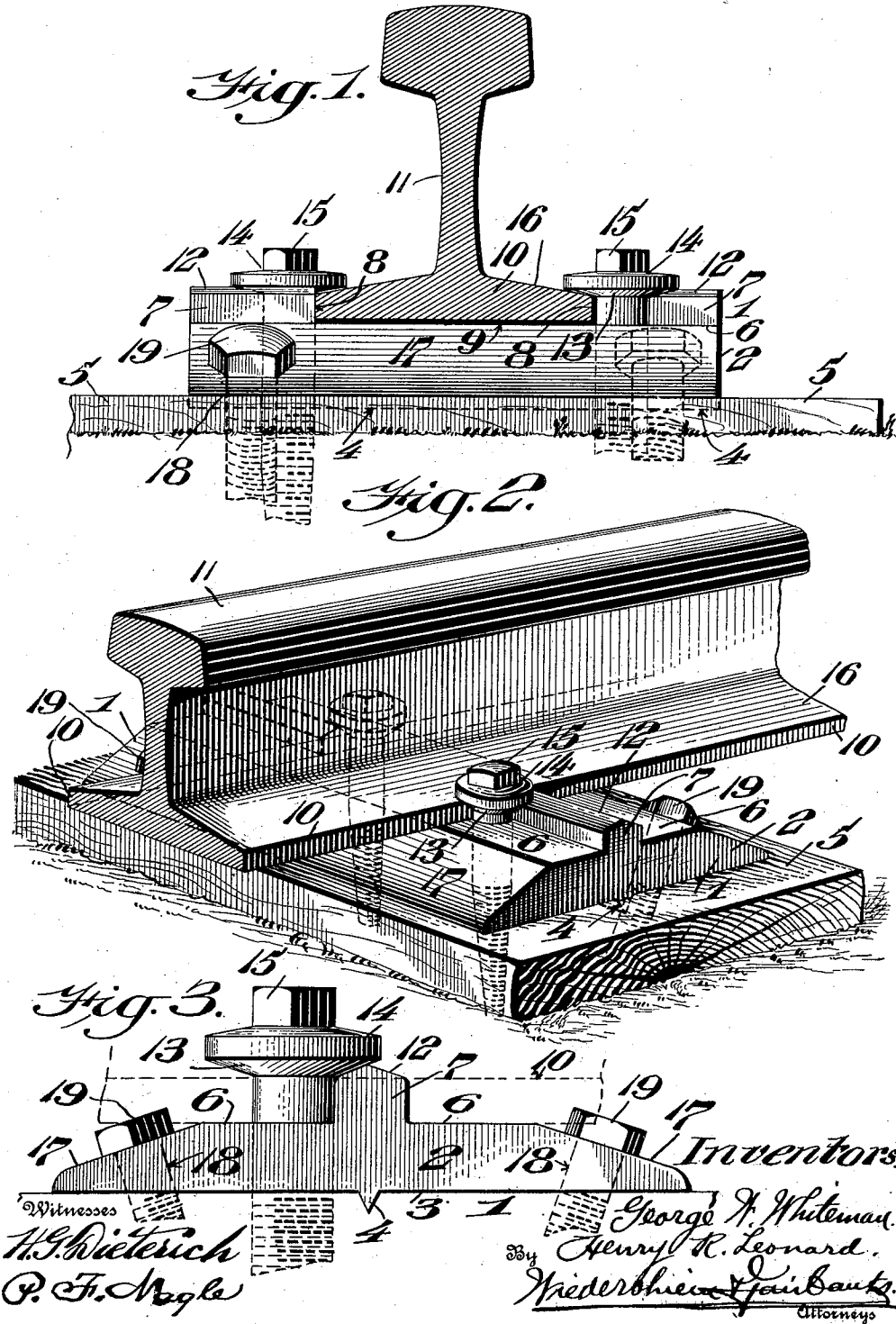

UNITED STATES PATENT OFFICE.

GEORGE W. WHITEMAN, OF PHILADELPHIA, AND HENRY R. LEONARD, OF WAYNE,
PENNSYLVANIA.

TIE-PLATE.

No. 916,904.

Specification of Letters Patent.

Patented March 30, 1909.

Application filed January 6, 1909. Serial No. 470,920.

To all whom it may concern:

Be it known that we, GEORGE W. WHITEMAN, a citizen of the United States, residing in the city and county of Philadelphia, State of Pennsylvania, and HENRY R. LEONARD, a citizen of the United States, residing at Wayne, county of Erie, State of Pennsylvania, have invented a new and useful Tie-Plate, of which the following is a specification.

Our invention consists of a novel construction of tie plate which can be made of rolled or cast metal and is provided with a rib, rolled or cast or otherwise secured to the top surface of the plate, said rib being sheared out or recessed so as to give a proper bearing to the rail base on its underside and edges, the top of said rib being rolled, cast or otherwise shaped so as to cooperate with and substantially conform to the bevel on the underside of the head of the screw spike or lag screw so that the underside of said head may coact with the contiguous portion of the upper surface of the rail base and the inclined surface of the rib whereby the rail, tie plate and tie may be properly and effectively held in assembled position.

A further object of our invention is in the provision of the center bearing for the rail base to keep the center of pressure of the rail and its load as near the center of the tie plate and tie as possible, thereby insuring a more even distribution of pressure on both the tie and underlying ballast, this center bearing feature of our tie plate with its more even distribution of pressure being in practice a very important feature since it lessens the tendency of the tie plate rocking on the tie and furthermore prevents cutting of the tie along the edges of the tie plate whereby the life of the tie is greatly prolonged.

To the above ends, our invention consists of a novel construction of tie plate having a rib preferably centrally located on the upper surface of the tie plate and recessed for the reception of a rail base, the outer edges of the tie plate which extend transversely to the rail base being beveled and adapted to receive fastening devices which are adapted to extend at an angle into the tie and the upper surface of said rib being beveled or shaped so as to substantially conform to the inclination of the underside of the screw spike, lag screw or other fastening device.

It further consists of other novel features

of construction, all as will be hereinafter fully set forth.

Figure 1 represents a side view of a tie plate embodying our invention showing the manner of assembling the rail, tie plate and tie. Fig. 2 represents a perspective view of our novel tie plate. Fig. 3 represents an end view of the same.

For the purpose of illustrating our invention we have shown in the accompanying drawing one form thereof which is at present preferred by us, since the same has been found in practice to give satisfactory and reliable results, although it is to be understood that the various instrumentalities of which our invention consists can be variously arranged and organized and that our invention is not limited to the precise arrangement and organization of these instrumentalities as herein shown and described.

Similar numerals of reference indicate corresponding parts in the figures.

Referring to the drawings, 1 designates a tie plate, the same consisting of the body portion 2, from the underside 3 of which projects the longitudinally extending rib or spur 4, which is adapted to engage the tie 5, which may be of wood or other material.

6 designates the top surface of the tie plate, the latter having the longitudinally extended rib 7 rolled or cast on the top surface of the plate, said rib being sheared out or recessed as indicated at the points 8 in Fig. 1, whereby a recess or seat 9 is formed, upon which the base 10 of the rail 11 is seated, said rail base being prevented from lateral shifting by its contact with the walls or points 8, as will be evident. The top surfaces of the recessed top rib 7 are rolled or cast or otherwise provided with the upwardly converging surfaces 12, the inclination or angle or bevel of said surfaces 12 substantially conforming to the angle of the underside 13 of the head 14 of the screw spike or lag screw 15, it being noted that the inclination or bevel of the underside 13 of the screw spike is substantially the same as the contiguous surface 12 of the rib 7 and the top 16 of the rail base 10, so that as the spike 15 is screwed into position on opposite sides of the recess 9, as indicated in Fig. 2, it simultaneously secures the tie plate to the tie and also secures the rail firmly into place by the coaction of the underside of the head 14 with the juxtaposed top surfaces 12 and

16 of the rib and rail base respectively. The outer edges of the tie plate are beveled as indicated at 17 and provided with the holes 18 in which are located the screws, spikes or
 5 other fastening devices 19.

The preferred arrangement of the fastening devices 15 and 19 with respect to each other will be understood from Fig. 2, wherein, it will be seen that the fastening
 10 devices 19 are located at opposite corners or ends of the plate and enter the tie plate on converging lines while the screw spikes 15 engage the opposite portions of the rail base and the rib 7 in such a way that the rail
 15 is rigidly secured in position to the tie plate and the latter is rigidly secured to the tie by preferably four fastening devices which are applied in the most effective manner, so as to obtain the most efficient results.

It will be apparent that our novel construction of tie plate may be rolled, cast or otherwise produced, the rib 7 being preferably integral with or simultaneously produced during the process of construction of
 20 the plate, or if desired the rib may be welded or otherwise secured to the body of the tie plate without departing from the spirit of our invention.

It will be apparent that various slight changes may be made by those skilled in the art which will come within the scope of our invention and we reserve to ourselves the right to make all such changes as are within
 30 the scope of the same.

Having thus described our invention, what we claim as new and desire to secure by Letters Patent, is:—

1. A tie plate consisting of a body portion, having a rib on the upper surface thereof,
 40 said rib being recessed and adapted to receive a rail base, the top surfaces of said rib being inclined and converging upwardly and adapted to co-act with the underside of the heads of fastening devices, the walls of
 45 said recess being adapted to prevent lateral movement of said rail base.

2. A tie plate consisting of a body portion, having a rib on the upper surface thereof,
 50 said rib being recessed to the level of the top of said tie plate and adapted to receive a rail base, the top surfaces of said rib on each side of the recess therein converging upwardly and the edges of said plate which extend transversely to said rail base being
 55 beveled so as to converge upwardly and having openings therein for the reception of fastening devices.

3. A tie plate consisting of a body portion, having a rib on the upper surface thereof,
 60 said rib being recessed to the level of the top of said tie plate and adapted to receive a rail base, the top surfaces of said rib on each side of the recess therein converging upwardly and the edges of said plate which extend
 65 transversely to said rail base being beveled

so as to converge upwardly and having openings therein for the reception of fastening devices, said tie plate on its under surface having a rib adapted to engage the body of the
 70 tie.

4. A tie plate consisting of a body portion having a rib on the upper surface thereof, said rib being recessed in its central portion for the reception of a rail base, and said rib having its top surfaces converged upwardly
 75 so as to substantially conform to the inclination of the under side of the head of the co-acting lag screws and to the inclination of the top surface of the rail base.

5. A tie plate consisting of a body portion, having a rib on the upper surface thereof, said rib being recessed in its central portion for the reception of a rail base and said rib having its top surfaces converging upwardly
 80 so as to substantially conform to the inclination of the underside of the heads of the co-acting fastening devices and to the inclination of the top surface of the rail base, said
 85 plate having its edges extending transversely to said rail base beveled and adapted to have fastening devices passing therethrough into
 90 the body of the tie at an angle to each other.

6. As an improved article of manufacture, a tie plate having a body portion, a longitudinally extending rib 7 thereon provided
 95 with the upwardly converging surfaces 12, a recess 9 in said rib adapted to receive the rail base, said tie plate having the inclined edges 17 provided with the inclined openings 18 therein, and said tie plate also having
 100 openings contiguous to the ends of the recess in said rib and out of alinement with said rib for the reception of other fastening devices.

7. As an improved article of manufacture, a tie plate having a body portion, a longitudinally extending rib 7 thereon provided
 105 with the upwardly converging surfaces 12, a recess 9 in said rib adapted to receive the rail base, said tie plate having the inclined edges 17 provided with the inclined openings 18 therein, and said tie plate also having
 110 openings contiguous to the ends of the recess in said rib and out of alinement with said rib, for the reception of other fastening
 115 devices, in combination with the lower rib 4, adapted to engage the body of the tie.

8. The combination of a rail base, a tie plate having a rib on the top thereof, the central portion of said rib being recessed to the
 120 level of the top of said tie plate and adapted to receive said rail base, said plate having openings and lag screws in said openings for securing said rail base and tie plate in position, the upper surfaces of said rib converging
 125 upwardly and having an inclination conforming substantially to the inclination of the contiguous surface of the heads of said screws.

9. The combination of a rail base, a tie, a 130

tie plate having a rib on the top thereof, the
central portion of said rib being recessed and
adapted to receive said rail base, openings in
said plate, lag screws in said openings for se-
5 curing said rail base and tie plate in position,
the upper surfaces of said rib converging up-
wardly and having an inclination conform-
ing substantially to the inclination of the
contiguous surface of the heads of said
10 screws, the edges of said tie plate being
beveled, the underside of said tie plate hav-

ing a longitudinally extending wedge shaped
rib thereon adapted to engage the body of
said tie and fastening devices extending
through said beveled edge into the body of 15
the tie and at an angle to each other.

GEORGE W. WHITEMAN.
HENRY R. LEONARD.

Witnesses:

E. HAYWARD FAIRBANKS,
C. D. McVAY.