

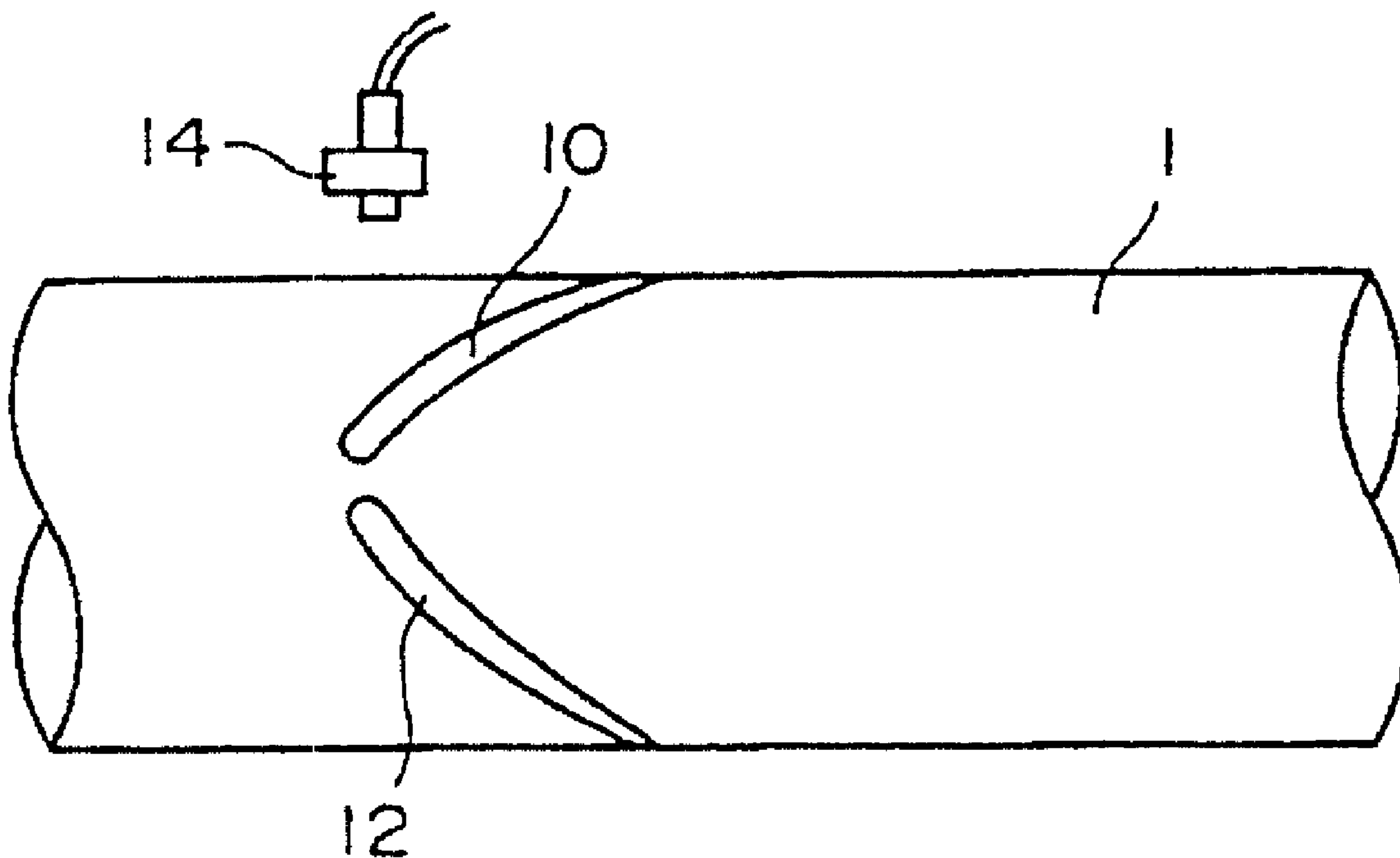

(22) Date de dépôt/Filing Date: 2001/08/17
 (41) Mise à la disp. pub./Open to Public Insp.: 2002/03/18
 (45) Date de délivrance/Issue Date: 2006/05/30
 (30) Priorité/Priority: 2000/09/18 (JP20000-281826)

(51) Cl.Int./Int.Cl. *G01B 7/14* (2006.01),
G01B 7/00 (2006.01), *G01B 21/32* (2006.01),
G01B 11/16 (2006.01), *G01B 7/24* (2006.01),
G01B 7/16 (2006.01)
 (72) Inventeurs/Inventors:
 KONDO, MITSURU, JP;
 HIROKAWA, KAZUHARU, JP
 (73) Propriétaire/Owner:
 MITSUBISHI HEAVY INDUSTRIES, LTD., JP
 (74) Agent: RICHES, MCKENZIE & HERBERT LLP

(54) Titre : METHODE ET DISPOSITIF DE MESURE DE L'ALLONGEMENT AXIAL D'UN ARBRE ROTATIF
 (54) Title: ROTARY SHAFT AXIAL ELONGATION MEASURING METHOD AND DEVICE



(57) Abrégé/Abstract:

Rotary shaft axial elongation measuring method and device enable an accurate measuring of a rotary shaft axial elongation regardless of sizes of the elongation. Grooves (10, 12), arranged mutually opposing in a turned V shape along axial direction, are provided in a rotational surface of a rotary shaft (1), axial elongation of which is to be measured. A sensor (14) is arranged opposing the rotational surface of the rotary shaft (1). The sensor (14) generates pulses upon passing of the grooves (10, 12) following rotation of the rotary shaft (1). As a circumferential interval between the grooves (10, 12) differs according to the axial directional position of the rotary shaft (1), if the positions of the grooves (10, 12) at the position of the sensor (14) change due to the axial elongation, interval of the pulses generated by the sensor (14) changes. Thus, by the change in the pulse generation interval, the axial elongation is measured.

Abstract of the Disclosure

Rotary shaft axial elongation measuring method and device enable an accurate measuring of a rotary shaft axial elongation regardless of sizes of the elongation. Grooves (10, 12), arranged mutually opposing in a turned V shape along axial direction, are provided in a rotational surface of a rotary shaft (1), axial elongation of which is to be measured. A sensor (14) is arranged opposing the rotational surface of the rotary shaft (1). The sensor (14) generates pulses upon passing of the grooves (10, 12) following rotation of the rotary shaft (1). As a circumferential interval between the grooves (10, 12) differs according to the axial directional position of the rotary shaft (1), if the positions of the grooves (10, 12) at the position of the sensor (14) change due to the axial elongation, interval of the pulses generated by the sensor (14) changes. Thus, by the change in the pulse generation interval, the axial elongation is measured.

ROTARY SHAFT AXIAL ELONGATION MEASURING**METHOD AND DEVICE****BACKGROUND OF THE INVENTION**5 **Field of the Invention**

The present invention relates to an axial elongation measuring method and a device therefor of a rotary shaft, such as a gas turbine or steam turbine rotor shaft, that elongates in the axial direction.

10

Description of the Prior Art

15

As a rotor shaft of a gas turbine or steam turbine causes an axial elongation according to temperature change, it is necessary to accurately monitor whether the elongation is within a predetermined range or not so that no mutual contact of a moving blade and a stationary blade may be caused. One example of the prior art to measure the axial elongation of a rotary shaft with such an object is to use a gap sensor to detect a gap caused by the axial elongation, as shown in Fig. 7.

20

25

In Fig. 7, numeral 1 designates a rotary shaft and this rotary shaft 1 is provided with a target face 2 for measuring the axial elongation. A gap sensor 4 is arranged so as to oppose the target face 2. The gap sensor 4 is fitted to a stationary part 6. The gap sensor 4 measures a gap 8 between

the target face 2 and the sensor 4 and, by the change of this gap 8, the axial elongation of the rotary shaft 1 is measured.

In the prior art axial elongation measuring device as mentioned above, the elongation of the rotary shaft 1 is directly measured by the gap sensor 4 relative to the stationary part 6. Therefore, in case the axial elongation of the rotary shaft 1 is large, it is necessary to measure the gap 8 over a wide range, but to measure the gap 8 by the gap sensor 4 over the wide range often results in the less accuracy.

Also, as the gap sensor 4 is provided in the axial directional space around the rotary shaft 1 where the gap 8 to be measured exists, a certain space is required in the axial direction of the rotary shaft 1 for installing the gap sensor 4.

SUMMARY OF THE INVENTION

In view of the mentioned problems in the prior art rotary shaft axial elongation measuring device, it is an object of the present invention to provide a rotary shaft axial elongation measuring method and a device therefor that are free from such problems as mentioned above and are able to measure an axial elongation of a rotary shaft with a high accuracy regardless of sizes of the axial elongation.

As a rotary shaft axial elongation measuring method for

solving the mentioned problems, the present invention provides a rotary shaft axial elongation measuring method for measuring an axial elongation of a rotary shaft, characterized in comprising the steps of: providing a reference mark and a
5 measuring mark on a rotational surface of the rotary shaft, the measuring mark being arranged inclinedly relative to an axial direction of the rotary shaft; arranging a sensor fixedly so as to oppose the rotational surface of the rotary shaft, the sensor generating pulses upon passing of the marks
10 following a rotation of the rotary shaft; and measuring the axial elongation of the rotary shaft from a change in an interval of the pulses generated by the sensor upon passing of the reference mark and measuring mark.

According to the axial elongation measuring method of
15 the present invention, as the measuring mark is provided inclinedly relative to the axial direction of the rotary shaft, the circumferential directional position of the measuring mark line relative to the position of the reference mark changes according to the axial directional position
20 thereof. On the other hand, the sensor generates the pulses when the reference mark and the measuring mark pass by the sensor following the rotation of the rotary shaft and hence, if the axial directional position of the rotary shaft opposing the sensor changes due to the axial elongation of the rotary
25 shaft, then the interval of the pulses generated by the sensor

differs. Consequently, by measuring the change in the interval of the pulses generated by the sensor, the axial elongation of the rotary shaft can be measured.

In the mentioned axial elongation measuring method of the present invention, the steps are simplified such that the reference mark, and the measuring mark arranged inclinedly relative to the axial direction of the rotary shaft, are provided on the rotational surface of the rotary shaft, the axial elongation of which is to be measured, and the sensor is arranged fixedly so as to oppose the rotational surface of the rotary shaft for generating pulses upon passing by of the mentioned marks following the rotation of the rotary shaft. Hence, the gap between the sensor and the rotational surface of the rotary shaft opposing the sensor does not change substantially by the axial elongation of the rotary shaft and the accuracy of measuring the axial elongation by the sensor is in no case reduced by the sizes of the axial elongation. Also, according to the method of the present invention, there is no need to install such a sensor and a target face as in the prior art case in the axial directional space around the rotary shaft and thus there occurs no case where the measuring becomes impossible due to a limitation in the axial directional space of the rotary shaft.

Also, as a rotary shaft axial elongation measuring device for solving the mentioned problems, the present

invention provides a rotary shaft axial elongation measuring device for measuring an axial elongation of a rotary shaft, characterized in comprising: a reference mark and a measuring mark provided on a rotational surface of the rotary shaft, the measuring mark being arranged inclinedly relative to an axial direction of the rotary shaft; a sensor arranged fixedly so as to oppose the rotational surface of the rotary shaft, the sensor generating pulses upon passing of the marks following a rotation of the rotary shaft; and a data processing part for measuring the axial elongation of the rotary shaft from a change in an interval of the pulses generated by the sensor upon passing of the reference mark and measuring mark.

According to the rotary shaft axial elongation measuring device of the present invention, such a device is provided as is able to measure the axial elongation of the rotary shaft based on the axial elongation measuring method of the present invention as mentioned above.

In the axial elongation measuring device of the present invention, as the construction is made such that the axial elongation data is obtained by the sensor arranged fixedly so as to oppose the rotational surface of the rotary shaft, the gap between the sensor and the rotational surface is constant regardless of sizes of the axial elongation of the rotary shaft and measuring of the axial elongation with a high accuracy can be performed.

Also, in the axial elongation measuring device of the present invention, as the sensor may be arranged with a predetermined gap being maintained between itself and the rotational surface of the rotary shaft, only a narrow space is required for measuring the axial elongation regardless of sizes of the axial elongation.

The reference mark and the measuring mark provided on the rotational surface of the rotary shaft in the axial elongation measuring device of the present invention may be two marks provided such that an interval between them in the circumferential direction of the rotary shaft differs according to the axial directional position of the rotary shaft. These two marks may be two grooves or two wire members both provided in a turned V shape.

Also, the measuring mark used in the axial elongation measuring device of the present invention may be a groove or a wire member both provided in a spiral shape on the rotational surface of the rotary shaft.

As mentioned above, the axial elongation measuring device of the present invention may be of a simple construction that is made easily and less costly.

The sensor used in the axial elongation measuring method and device of the present invention may be an ordinary gap sensor, such as a capacitance type gap sensor or eddy current gap sensor, or may be a photoelectric sensor that generates a

pulse signal upon passing of a mark provided on the rotational surface.

According to the present invention as described above, even in the case where the rotary shaft affords no space for measuring by the conventional art to thereby make the measuring of the axial elongation impossible, the measuring device that can be easily
5 installed for enabling the measuring of the axial elongation is provided.

In one aspect, the present invention provides a rotary shaft axial elongation measuring method for measuring an axial elongation of a rotary shaft, comprising the steps of: providing a reference mark and a measuring mark on a rotational surface of said rotary shaft (1), said reference mark and said measuring mark are arranged reversely or oppositely
10 inclined to each other relative to an axial direction of said rotary shaft (1) so as to form a turned V shape by said two marks, arranging a sensor (14) fixedly so as to oppose the rotational surface of said rotary shaft (1), said sensor (14) generating pulses upon passing of said marks following a rotation of said rotary shaft (1); and measuring the axial elongation of said rotary shaft (1) from a change in ratio between an interval of the pulses
15 generated by said sensor (14) upon passing of said reference mark and measuring mark and an interval of successive pulses generated by the sensor (14) upon the successive passing of a selected one of the reference mark and the measuring mark during the rotation of the rotary shaft (1).

In another aspect, the present invention provides a rotary shaft axial elongation
20 measuring device for measuring an axial elongation of a rotary shaft, comprising: a reference mark and a measuring mark provided on a rotational surface of said rotary shaft (1), said reference mark and said measuring mark are generally arranged reversely or oppositely inclined to each other relative to an axial direction of said rotary shaft (1) so as to form a turned V shape by said two marks, a sensor (14) arranged fixedly so as to oppose
25 the rotational surface of said rotary shaft (1), said sensor (14) generating pulses upon passing of said marks following a rotation of said rotary shaft (1);

and a data processing part (16) for measuring the axial elongation of said rotary shaft (1) from a change in ratio between an interval of the pulses generated by said sensor (14) upon passing of said reference mark and measuring mark and an interval of successive pulses generated by said sensor (14) upon the successive passing of a selected one of the reference
5 mark and the measuring mark during the rotation of the rotary shaft (1).

In another aspect, the present invention provides a method of measuring axial elongation of a rotary shaft, comprising: providing two marks on a rotational surface of a rotary shaft such that the marks are oppositely inclined to one another so as to form a V shape turned relative to an axial direction of the rotary shaft so that a circumferential
10 direction interval between the marks changes according to the axial direction position along the rotary shaft; providing a sensor opposite to the marks on the rotational surface of the rotary shaft, the sensor being operable to generate pulses when the marks pass the sensor during rotation of the rotary shaft; and measuring the axial elongation of the rotary shaft from a change in an interval ratio of the pulses generated by the sensor when the marks
15 pass the sensor during rotation of the rotary shaft.

In a further aspect, the present invention provides a rotary shaft axial elongation measuring device, comprising: two marks provided on a rotational surface of a rotary shaft, wherein said marks are oppositely inclined to one another relative to an axial direction of the rotary shaft such that a circumferential direction interval between the marks
20 change according to the axial direction position along the rotary shaft; a sensor positioned opposite to the marks on the rotational surface of said rotary shaft, said sensor being operable to generate pulses when said marks pass said sensor during rotation of the rotary shaft; and a data processing part operable to determine axial elongation of the rotary shaft from a change in an interval ratio of the pulses generated by said sensor when said marks
25 pass said sensor during rotation of the rotary shaft.

BRIEF DESCRIPTION OF THE DRAWINGS

Figs. 1(a) and 1(b) show a rotary shaft used in a first embodiment according to the present invention, wherein Fig. 1(a) is a side view and Fig. 1(b) is a front view.

5 Figs. 2(a) and 2(b) are explanatory views showing the state where pulses generated by a sensor upon rotation of the rotary shaft of Figs. 1(a) and 1(b) change from Fig. 2(a) to Fig. 2(b) by an axial elongation.

Fig. 3 is a block diagram showing an entire construction of an axial elongation measuring device of the first embodiment according to the present invention.

10 Fig. 4 is an explanatory view showing the relation between an accuracy of the axial elongation measuring by the present invention and that by the prior art.

Fig. 5 is a side view showing a rotary shaft used in a second embodiment according to the present invention.

Fig. 6 is an explanatory view showing changes caused by the axial elongation in pulses generated by a sensor upon rotation of the rotary shaft of Fig. 5.

Fig. 7 is a side view showing a construction of a prior art axial elongation measuring device.

DESCRIPTION OF THE PREFERRED EMBODIMENTS

Herebelow, a rotary shaft axial elongation measuring device of the present invention will be concretely described based on embodiments as illustrated.

(First Embodiment)

A first embodiment according to the present invention will be described with reference to Figs. 1 to 4. In Figs. 1(a) and 1(b), numerals 10 and 12, respectively, designate grooves, that are provided in a rotational outer circumferential surface of a rotary shaft 1 so as to oppose one another inclinedly in a turned V shape. Thus, the grooves 10, 12, opposing one another, extend inclinedly in an axial direction of the rotary shaft 1 and an interval between the grooves 10, 12 changes according to the axial directional position thereof, so that a construction is made such that one of the grooves 10, 12 constitutes a reference mark as hereinafter referred to and the other constitutes a measuring mark as hereinafter referred to.

Numerals 14 designates a sensor, that is arranged so as

to oppose the rotational outer circumferential surface of the rotary shaft 1. This sensor 14 may be a sensor, such as a capacitance type gap sensor, eddy current gap sensor or photoelectric sensor, that generates a pulse or pulse signal according to a change in a capacitance, eddy current or reflection of light following a change in a gap between the sensor 14 and the rotational outer circumferential surface of the rotary shaft 1 when the grooves 10, 12 pass by the sensor 14 by the rotation of the rotary shaft 1.

In the measuring device of Figs. 1(a) and 1(b) constructed as above, if the rotary shaft 1 rotates, the grooves 10, 12 pass by the sensor 14 and the sensor 14 puts out pulses, as shown in Figs. 2(a) and 2(b), corresponding to time t_1 that is a time from passing by the sensor 14 of the groove 10 to that of the groove 12 and time t_2 that is a time of one rotation of the rotary shaft 1.

As the position of the sensor 14 is fixed, if the rotary shaft 1 elongates in the axial direction and the axial directional position of the grooves 10, 12 changes, then the circumferential directional interval between the grooves 10, 12 at the position of the sensor 14 changes. Hence, by the axial elongation of the rotary shaft 1, the pulses generated by the sensor 14 change as shown in Fig. 2(b), so that the pulses change from those having a pulse interval ratio of t_1/t_2 in Fig. 2(a) to those having a different pulse interval

ratio of t_{12}/t_{22} in Fig. 2(b).

Thus, by measuring the change in the pulse interval ratio t_1/t_2 obtained by the sensor 14, the axial elongation of the rotary shaft 1 can be measured.

5 Fig. 3 is a block diagram showing an entire construction of the axial elongation measuring device, wherein the pulse interval ratio of the pulses detected by the sensor 14 is sent to a data processing part 16 and the axial elongation obtained at the data processing part 16 is displayed at a display part
10 18.

The grooves 10, 12 of the rotary shaft 1 may be provided in the outer circumferential surface of the rotary shaft 1 within the range of $1/2$ or less of the entire outer circumference as shown in Fig. 1(b) and then, if the ratio
15 t_1/t_2 is more than 0.5 ($t_1/t_2 > 0.5$), the axial elongation and the ratio t_1/t_2 can be decided correspondingly as $(1-t_1/t_2)$ and thereby the data processing can be simplified.

According to the means to measure the interval changes of the marks provided in the rotational outer circumferential
20 surface of the rotary shaft 1 by the sensor 14 arranged oppositely to this rotational surface as described above, as the gap between the sensor 14 and the rotational surface as the object to be measured is constant regardless of the axial elongation, the measuring accuracy can be maintained
25 constant. This is shown by Fig. 4, wherein ① shows the

accuracy of the present invention and ② shows the state where the measuring accuracy becomes lower as the gap between the sensor and the object to be measured becomes larger by the axial elongation as in the case shown in Fig. 7.

5 (Second Embodiment)

A second embodiment according to the present invention will be described with reference to Figs. 5 and 6. In Fig. 5, numeral 20 designates a spiral groove, that is provided in the rotational outer circumferential surface of the rotary shaft 1
10 over the axial elongation measuring range as shown there. Numeral 22 designates a groove, that constitutes a reference mark and is provided, extending in the axial direction, in the rotational outer circumferential surface of the rotary shaft 1. A sensor 14-1 is arranged so as to oppose the rotational
15 surface of the rotary shaft 1 at the position where the spiral groove 20 is provided and another sensor 14-2 is arranged so as to oppose the rotational surface of the rotary shaft 1 at the position where the groove 22 as the reference mark is provided.

20 In the measuring device of Fig. 5 described above, if the rotary shaft 1 rotates and the grooves 20, 22 pass by the sensors 14-1, 14-2, respectively, then the sensors 14-1, 14-2, respectively, put out pulses. Fig. 6 shows the state of the pulses generated, wherein ③ shows the pulses generated by the
25 sensor 14-2 corresponding to the rotational movement of the

groove 22 as the reference mark of the rotary shaft 1 and time
t3 is a time of one rotation of the rotary shaft 1. On the
other hand, ④ of Fig. 6 shows the pulses generated by the
sensor 14-1 when the spiral groove 20 passes by the sensor 14-
5 1 and each of the pulses is generated per rotation of the
rotary shaft 1.

As the spiral groove 20, being arranged in a spiral
form, changes its position to pass by the sensor 14-1
corresponding to the axial elongation of the rotary shaft 1,
10 time t4 of Fig. 6 that is a time difference between the pulses
③ , ④ changes corresponding to the axial elongation.
Consequently, by measuring the change in the ratio $t4/t3$, the
axial elongation of the rotary shaft 1 can be obtained, like
in the case of the first embodiment.

15 It is to be noted that, while the present invention has
been concretely described based on the embodiments as
illustrated, the present invention is not limited to these
embodiments but, needless to mention, may be added with
various modifications in the concrete structure and
20 construction thereof as come within the scope of the claims as
appended.

For example, while in the above embodiments, the grooves
are formed as the reference mark and the measuring mark
provided on the rotational surface of the rotary shaft 1, a
25 wire member, such as a wire made of aluminum or stainless

steel, may be fitted instead as a mark by spot welding or the like so as to form a projection on the rotational surface.

Also, while in the first embodiment, the two marks are arranged to oppose one another inclinedly in the turned V
5 shape, the arrangement may be made such that one of the marks is arranged in parallel with the axis of the rotary shaft 1 and the other is inclined relative to the axial direction so that forming of the marks may be facilitated.

WHAT IS CLAIMED IS:

1. A rotary shaft axial elongation measuring method for measuring an axial elongation of a rotary shaft, comprising the steps of:

5 providing a reference mark and a measuring mark on a rotational surface of said rotary shaft (1), said reference mark and said measuring mark are oppositely inclined to each other relative to an axial direction of said rotary shaft (1) so as to form a turned V shape by said two marks,

10 arranging a sensor (14) fixedly so as to oppose the rotational surface of said rotary shaft (1), said sensor (14) generating pulses upon passing of said marks following a rotation of said rotary shaft (1); and

15 measuring the axial elongation of said rotary shaft (1) from a change in ratio between an interval of the pulses generated by said sensor (14) upon passing of said reference mark and measuring mark and an interval of successive pulses generated by the sensor (14) upon the successive passing of a selected one of the reference mark and the measuring mark during the rotation of the rotary shaft (1).

2. A rotary shaft axial elongation measuring device for measuring an axial elongation of a rotary shaft, comprising:

20 a reference mark and a measuring mark provided on a rotational surface of said rotary shaft (1), said reference mark and said measuring mark are oppositely inclined to each other relative to an axial direction of said rotary shaft (1) so as to form a turned V shape by said two marks,

a sensor (14) arranged fixedly so as to oppose the rotational surface of said rotary shaft (1), said sensor (14) generating pulses upon passing of said marks following a rotation of said rotary shaft (1); and

a data processing part (16) for measuring the axial elongation of said rotary shaft (1) from a change in ratio between an interval of the pulses generated by said sensor (14) upon passing of said reference mark and measuring mark and an interval of successive pulses generated by said sensor (14) upon the successive passing of a selected one of the reference mark and the measuring mark during the rotation of the rotary shaft (1).

10 3. A rotary shaft axial elongation measuring device as claimed in Claim 2, wherein said two marks are two grooves (10, 12).

4. A rotary shaft axial elongation measuring device as claimed in Claim 2, wherein said two marks are two wire members.

15

5. A rotary shaft axial elongation measuring device as claimed in any one of Claims 2 to 4, wherein said sensor (14) is any one of a capacitance type gap sensor, an eddy current gap sensor and a photoelectric sensor.

20 6. A rotary shaft axial elongation measuring device as claimed in Claim 2, wherein said measuring mark is a groove (20) provided in a spiral shape.

7. A rotary shaft axial elongation measuring device as claimed in Claim 2, wherein said measuring mark is a wire member fitted in a spiral shape.

8. A rotary shaft axial elongation measuring device as claimed in any one of Claims 2 to 7, wherein said sensor (14) is any one of a capacitance type gap sensor, an eddy current gap sensor and a photoelectric sensor.
- 5 9. A method of measuring axial elongation of a rotary shaft, comprising:
providing two marks on a rotational surface of a rotary shaft such that the marks are oppositely inclined to one another so as to form a V shape turned relative to an axial direction of the rotary shaft so that a circumferential direction interval between the marks changes according to the axial direction position along the rotary shaft;
- 10 providing a sensor opposite to the marks on the rotational surface of the rotary shaft, the sensor being operable to generate pulses when the marks pass the sensor during rotation of the rotary shaft; and
measuring the axial elongation of the rotary shaft from a change in an interval ratio of the pulses generated by the sensor when the marks pass the sensor during
- 15 rotation of the rotary shaft.
10. The method of claim 9, wherein the marks comprise a reference mark and a measuring mark, and wherein the interval ratio of the pulses is the ratio of the time from detection of the reference mark until detection of the measuring mark to the time it takes
- 20 for one rotation of the rotary shaft as determined by the sensor.
11. The method of claim 9, wherein the sensor is fixed.
12. A rotary shaft axial elongation measuring device, comprising:

two marks provided on a rotational surface of a rotary shaft, wherein said marks are oppositely inclined to one another relative to an axial direction of the rotary shaft such that a circumferential direction interval between the marks change according to the axial direction position along the rotary shaft;

5 a sensor positioned opposite to the marks on the rotational surface of said rotary shaft, said sensor being operable to generate pulses when said marks pass said sensor during rotation of the rotary shaft; and

a data processing part operable to determine axial elongation of the rotary shaft from a change in an interval ratio of the pulses generated by said sensor when said marks
10 pass said sensor during rotation of the rotary shaft.

13 The rotary shaft axial elongation measuring device of claim 12, wherein said plurality of marks comprises a reference mark and a measuring mark.

15 14. The rotary shaft axial elongation measuring device of claim 13, wherein said reference mark and said measuring mark comprise two grooves in the rotational surface provided so as to form a V shape.

20 15. The rotary shaft axial elongation measuring device of claim 14, wherein said sensor is any one of a capacitance type gap sensor, an eddy current gap sensor and a photoelectric sensor.

25 16. The rotary shaft axial elongation measuring device of claim 13, wherein said reference mark and said measuring mark comprise two wire members fitted on the rotational surface of the rotary shaft in a V shape.

17. The rotary shaft axial elongation measuring device of claim 16, wherein said sensor is any one of a capacitance type gap sensor, an eddy current gap sensor and a photoelectric sensor.
- 5
18. The rotary shaft axial elongation measuring device of claim 13, wherein said sensor is any one of a capacitance type gap sensor, an eddy current gap sensor and a photoelectric sensor.
- 10 19. The rotary shaft axial elongation measuring device of claim 12, wherein said sensor is any one of a capacitance type gap sensor, an eddy current gap sensor and a photoelectric sensor.
- 15 20. The rotary shaft axial elongation measuring device of claim 12, wherein said plurality of marks comprises a reference mark and a measuring mark, and wherein the interval ratio of the pulses is the ratio of the time from detection of the reference mark until detection of the measuring mark to the time it takes for one rotation of the rotary shaft as determined by said sensor.
- 20 21. The rotary shaft axial elongation measuring device of claim 12, wherein said sensor is fixed.

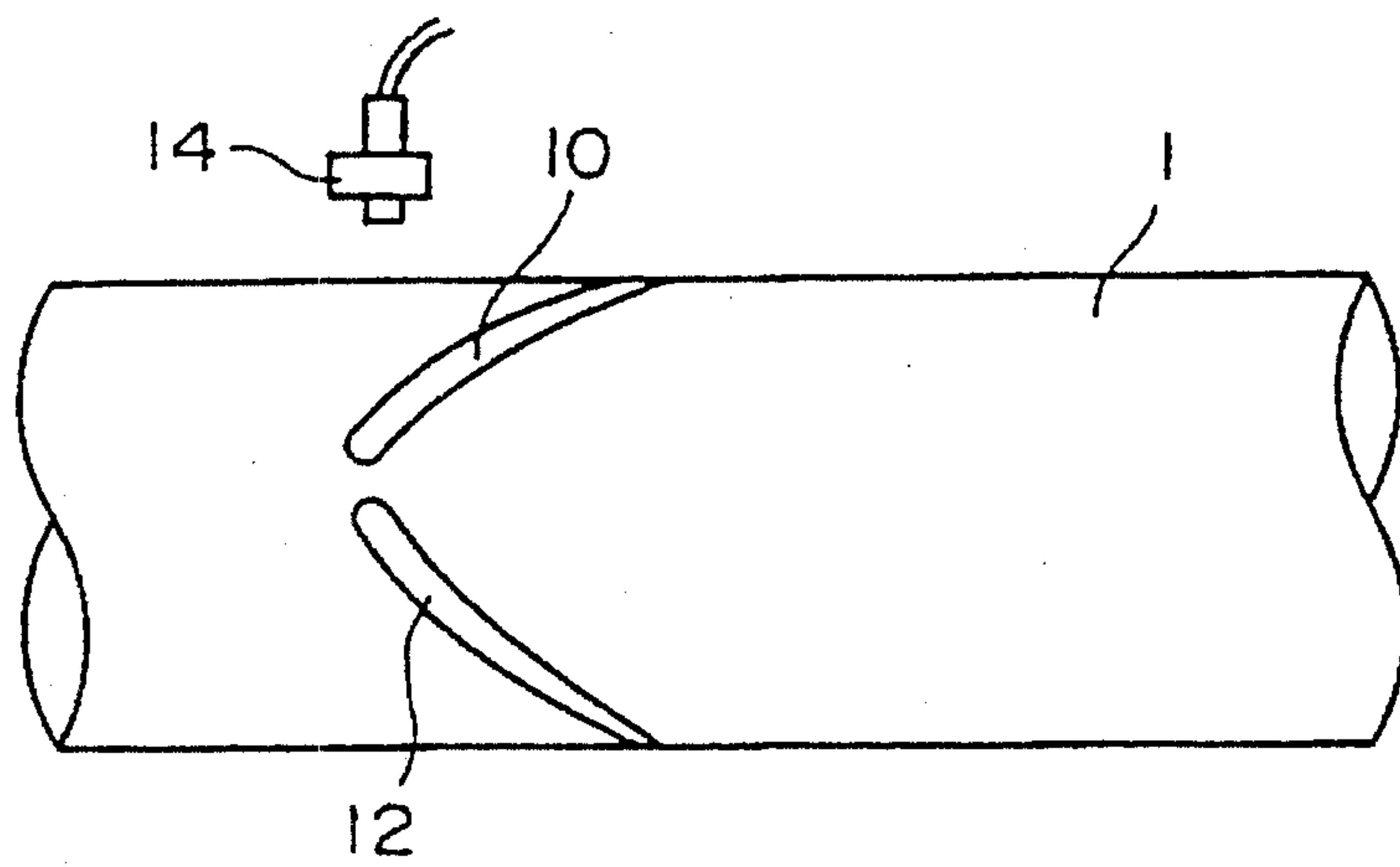

Fig. 1(a)

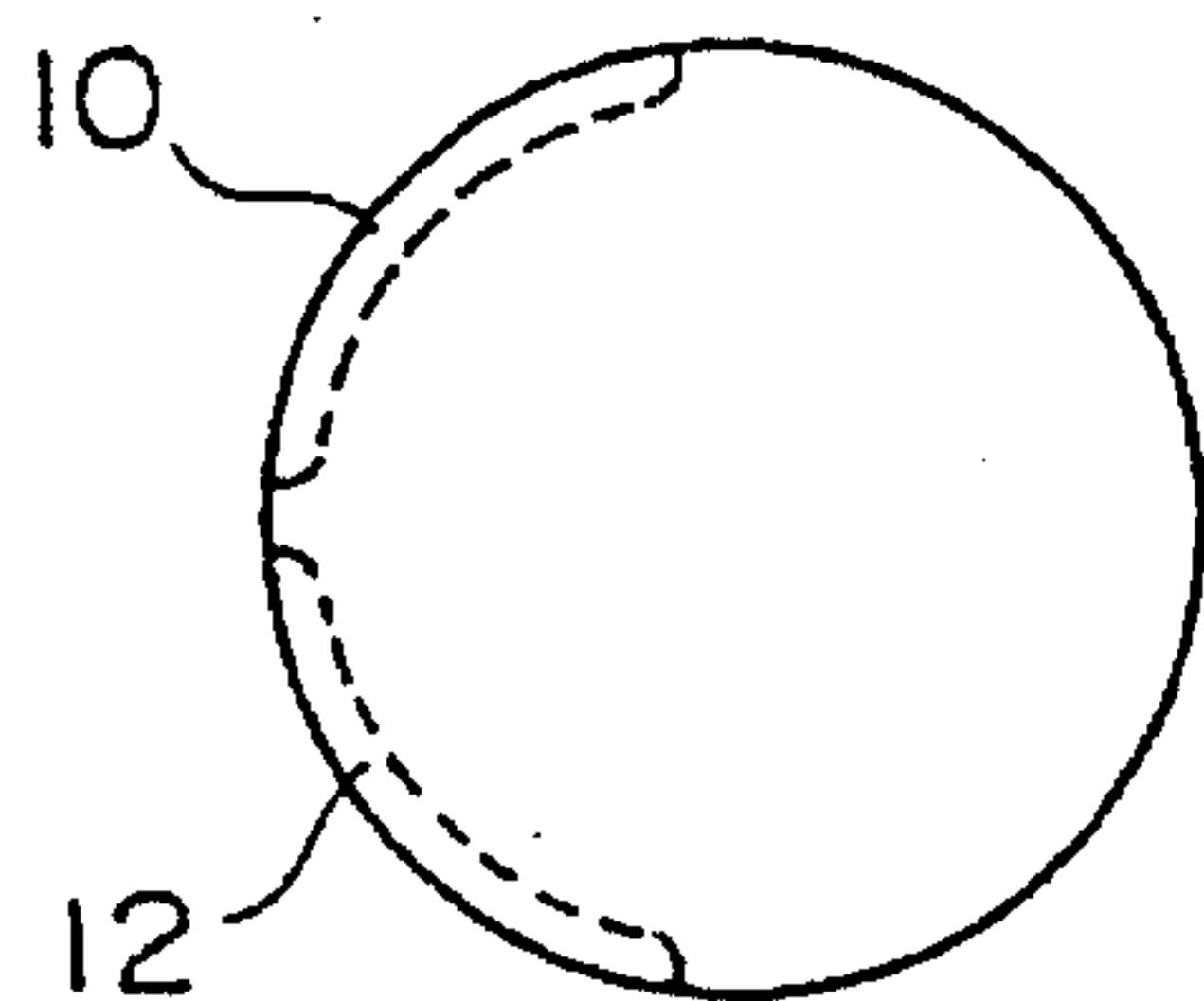

Fig. 1(b)

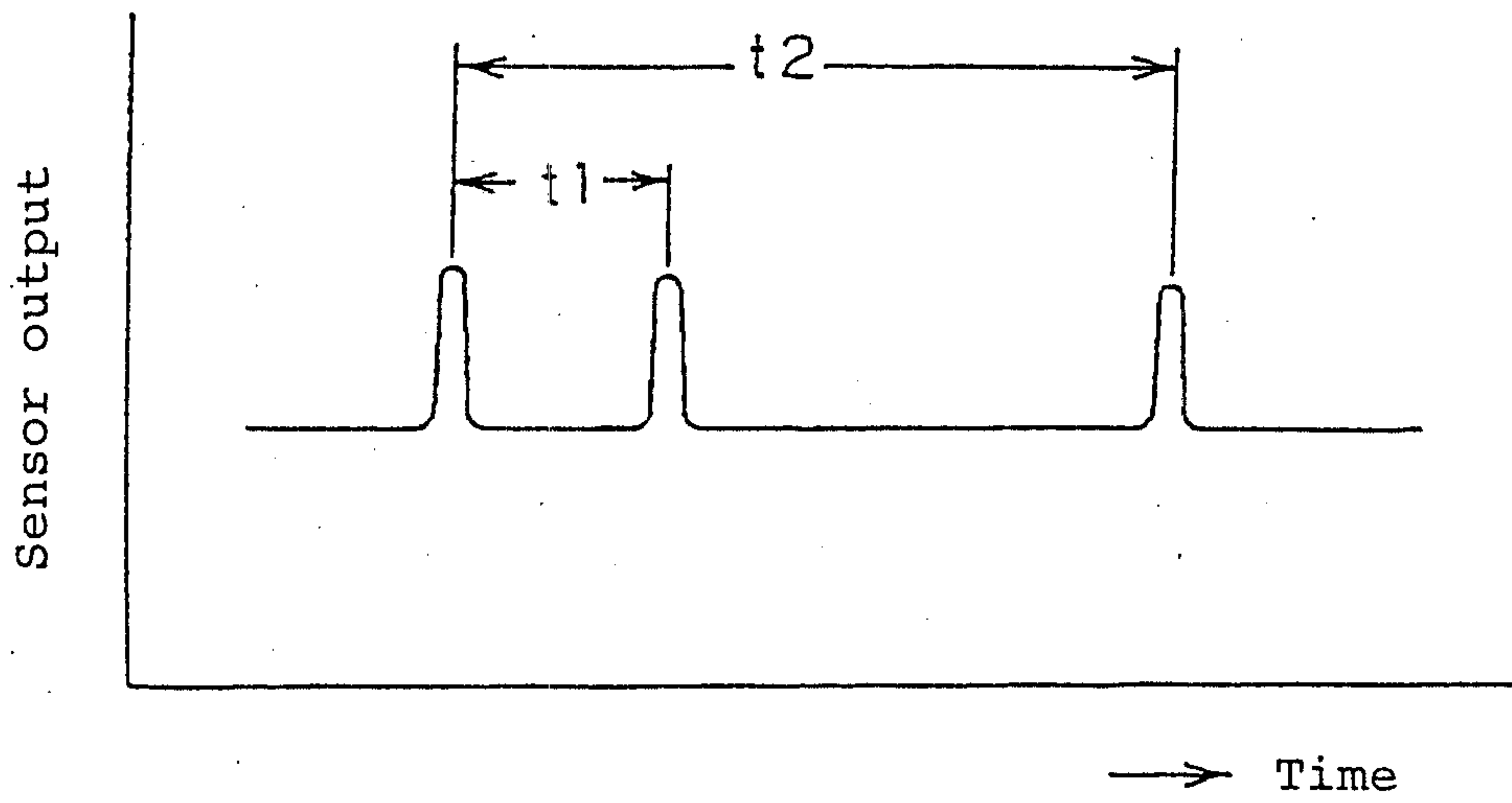

Fig. 2(a)

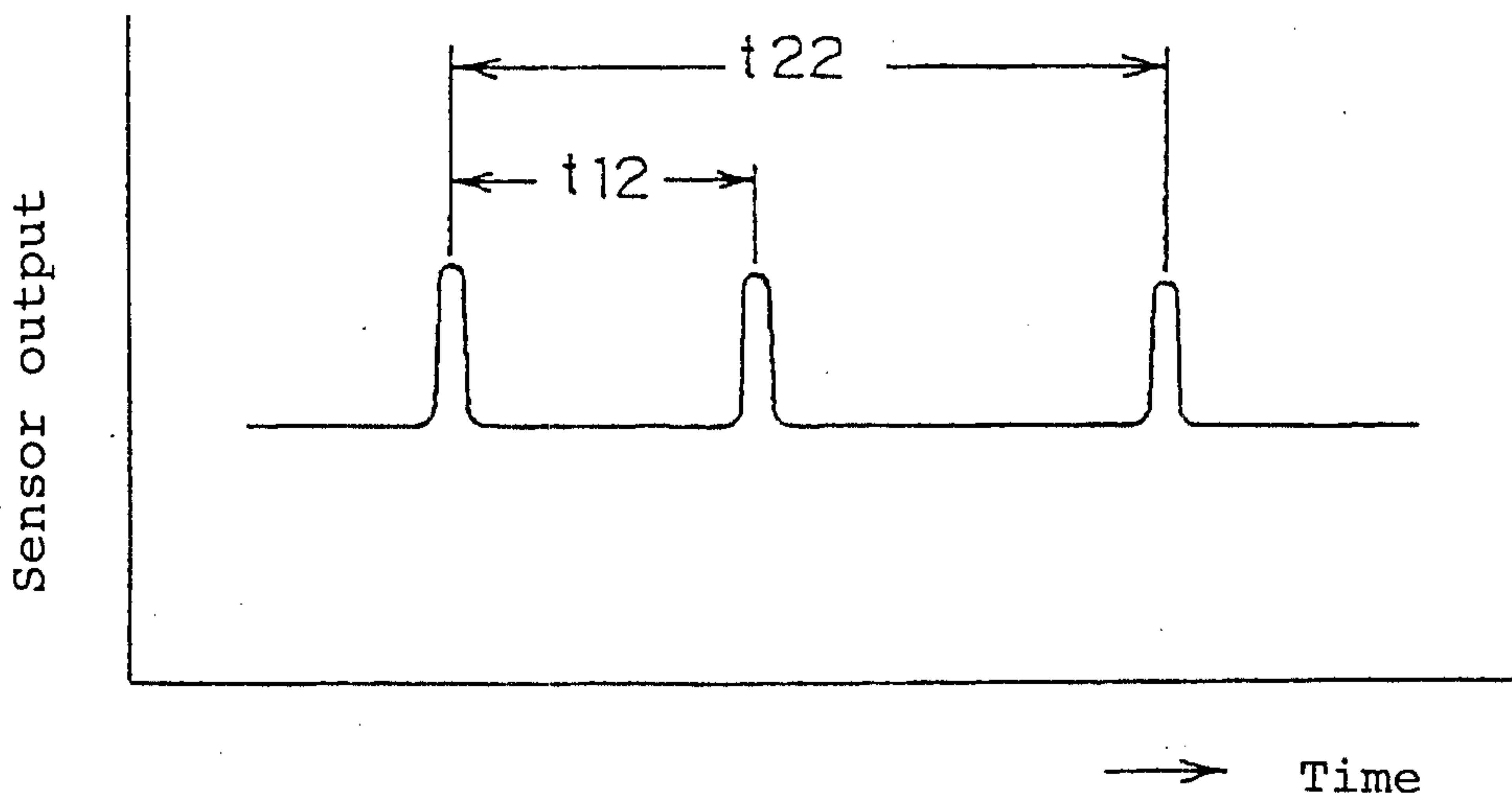

Fig. 2(b)

Fig. 3

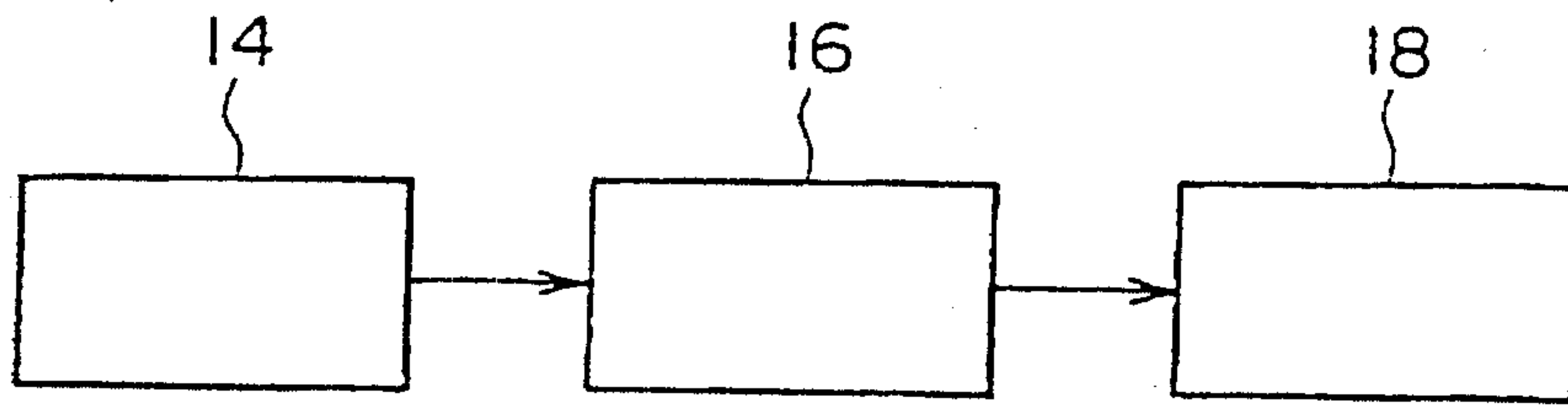

Fig. 4

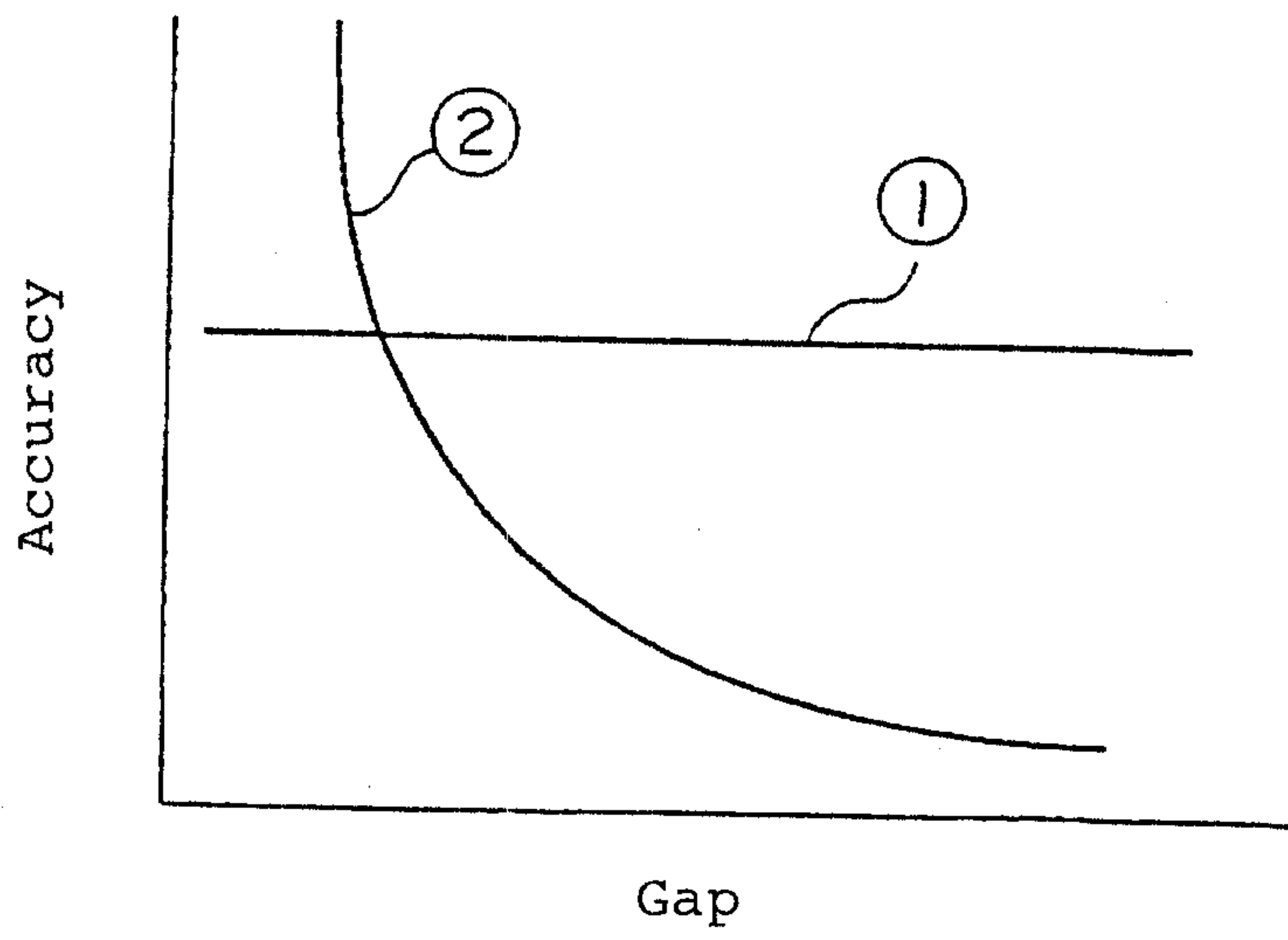
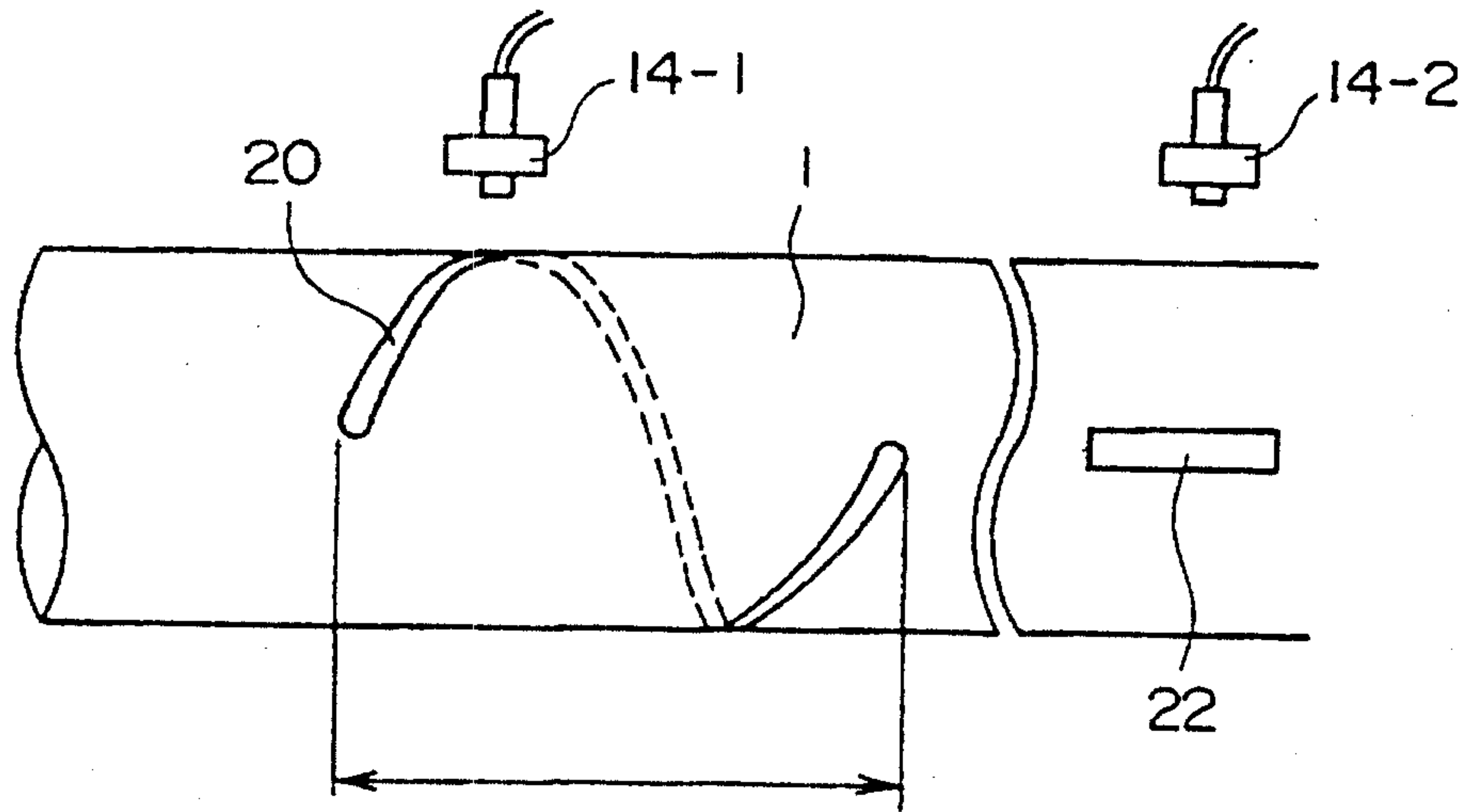

Fig. 5



Axial elongation measuring range

Fig. 6

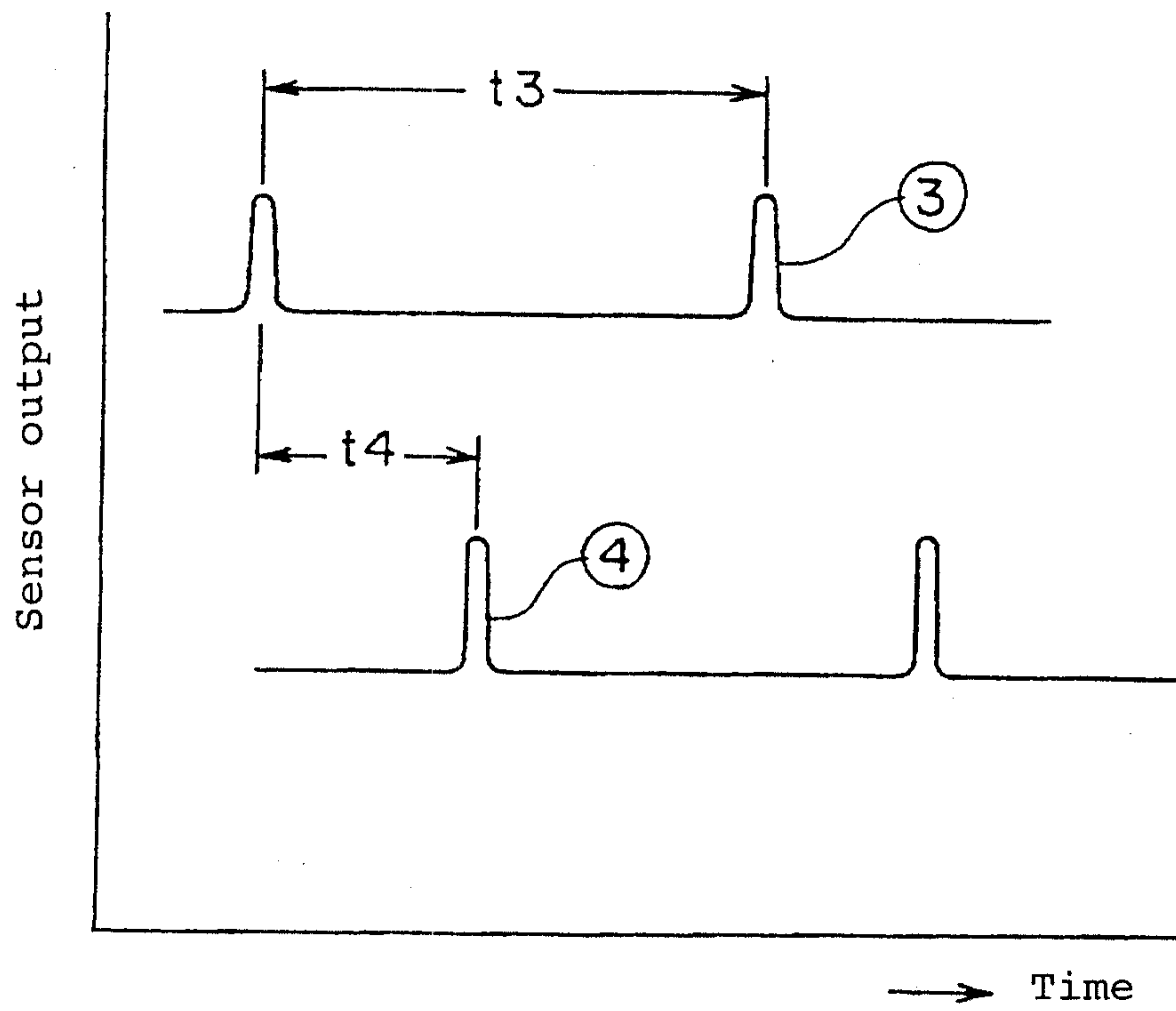

Fig. 7 (Prior Art)

