

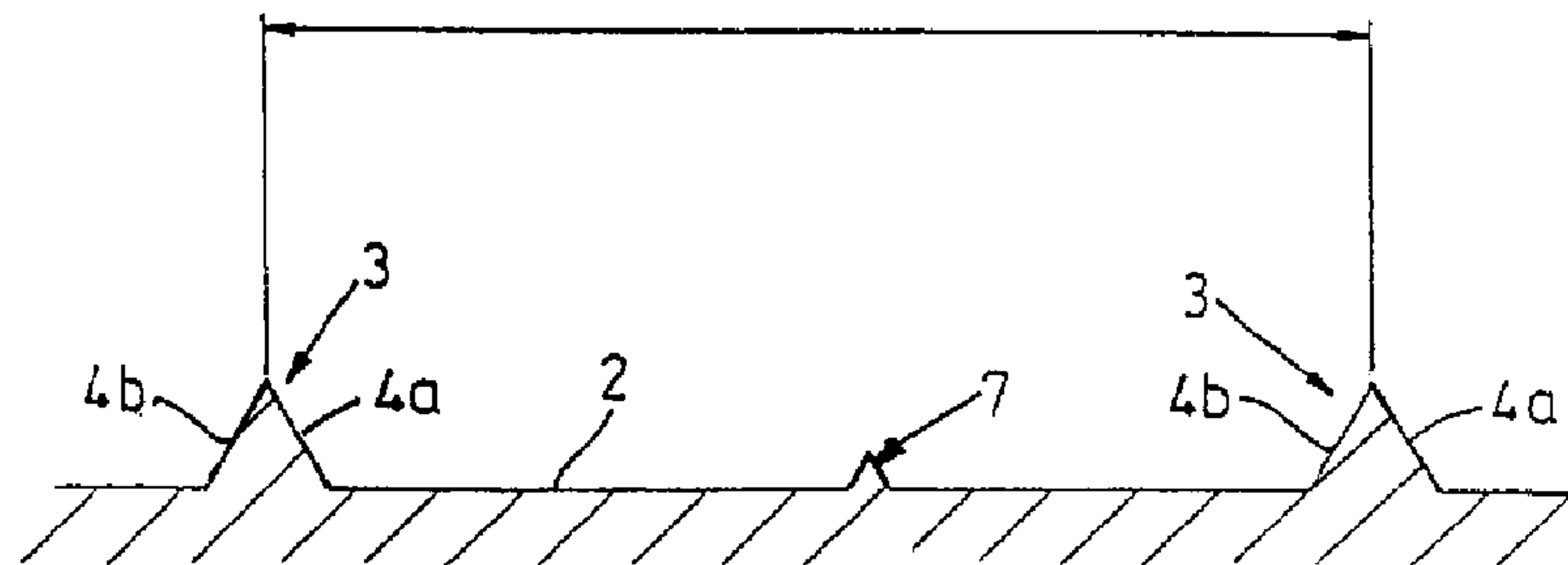

(86) Date de dépôt PCT/PCT Filing Date: 1998/07/27  
 (87) Date publication PCT/PCT Publication Date: 1999/02/04  
 (45) Date de délivrance/Issue Date: 2008/01/22  
 (85) Entrée phase nationale/National Entry: 2000/01/21  
 (86) N° demande PCT/PCT Application No.: GB 1998/002233  
 (87) N° publication PCT/PCT Publication No.: 1999/005421  
 (30) Priorité/Priority: 1997/07/26 (GB9715779.6)

(51) Cl.Int./Int.Cl. *F16B 33/02* (2006.01),  
*F16B 33/00* (2006.01), *F16B 25/00* (2006.01)  
 (72) Inventeur/Inventor:  
GLOVER, FRANK, GB  
 (73) Propriétaire/Owner:  
UNIFIX LIMITED, GB  
 (74) Agent: MACRAE & CO.

(54) Titre : ELEMENT D'ANCRAGE AMELIORE  
 (54) Title: IMPROVED FIXING ANCHOR

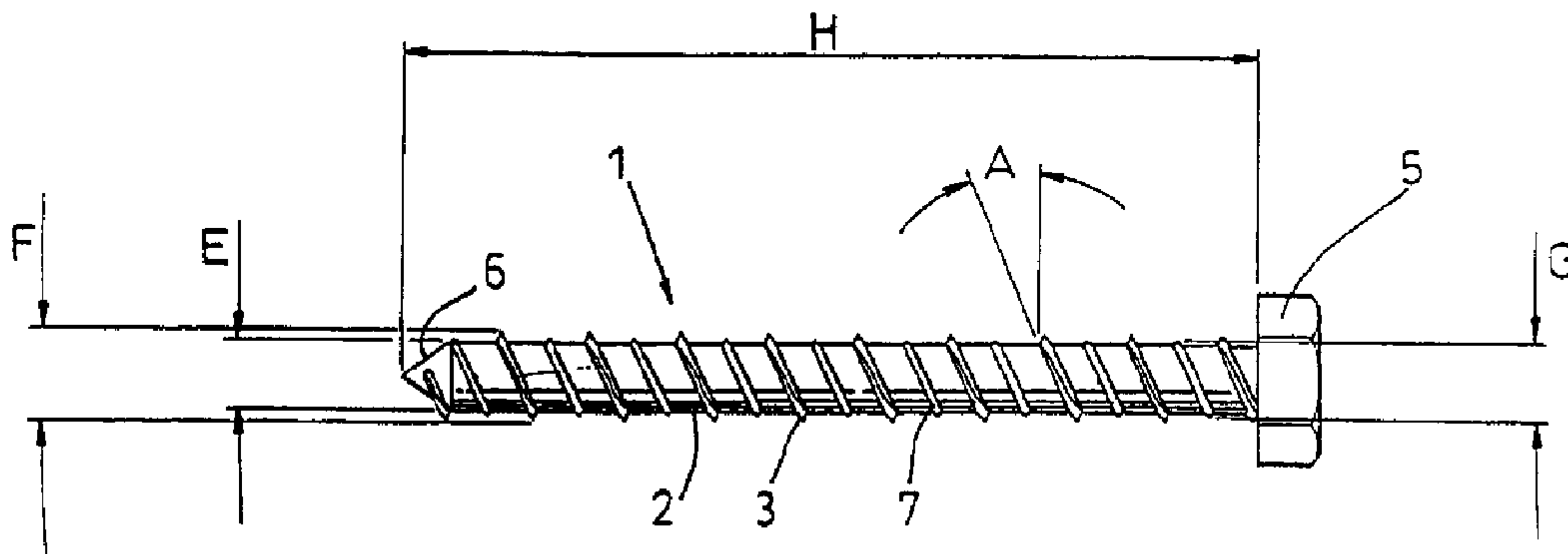

(57) Abrégé/Abstract:

A threaded fastener (1) is disclosed for anchoring into a substrate comprising a core portion (2) having at least one helical continuous thread provided along a substantial portion of the length of the core, in which the helical thread has a substantially V-shaped cross section defining two flanks (4a, 4b) which subtend an angle of between substantially 60° and 90°, and the thread has a helix angle of between approximately 20° and 45°. The crest of the thread may be flattened, and the fastener (1) is especially suited to anchoring to a masonry substrate.



PCT

WORLD INTELLECTUAL PROPERTY ORGANIZATION  
International Bureau

INTERNATIONAL APPLICATION PUBLISHED UNDER THE PATENT COOPERATION TREATY (PCT)

(51) International Patent Classification <sup>6</sup> : <b>F16B 33/02</b>	<b>A1</b>	(11) International Publication Number: <b>WO 99/05421</b> (43) International Publication Date: 4 February 1999 (04.02.99)
<p>(21) International Application Number: PCT/GB98/02233</p> <p>(22) International Filing Date: 27 July 1998 (27.07.98)</p> <p>(30) Priority Data: 9715779.6 26 July 1997 (26.07.97) GB</p> <p>(71) Applicant (for all designated States except US): UNIFIX LIMITED [GB/GB]; Bridge House, Grove Lane, Smethwick, Warley, West Midlands B66 2SA (GB).</p> <p>(72) Inventor; and (75) Inventor/Applicant (for US only): GLOVER, Frank [GB/GB]; 2 Velvetstone Cottage, Westwood Lane, Hatfield, Nr. Leominster, Herefordshire UR6 0SQ (GB).</p> <p>(74) Agent: BARKER BRETTELL; 138 Hagley Road, Edgbaston, Birmingham B16 9PW (GB).</p>	<p>(81) Designated States: AL, AM, AT, AU, AZ, BA, BB, BG, BR, BY, CA, CH, CN, CU, CZ, DE, DK, EE, ES, FI, GB, GE, GH, GM, HR, HU, ID, IL, IS, JP, KE, KG, KP, KR, KZ, LC, LK, LR, LS, LT, LU, LY, MD, MG, MK, MN, MW, MX, NO, NZ, PL, PT, RO, RU, SD, SE, SG, SI, SK, SL, TJ, TM, TR, TT, UA, UG, US, UZ, VN, YU, ZW, ARIPO patent (GH, GM, KE, LS, MW, SD, SZ, UG, ZW), Eurasian patent (AM, AZ, BY, KG, KZ, MD, RU, TJ, TM), European patent (AT, BE, CH, CY, DE, DK, ES, FI, FR, GB, GR, IE, IT, LU, MC, NL, PT, SE), OAPI patent (BF, BJ, CF, CG, CI, CM, GA, GN, GW, ML, MR, NE, SN, TD, TG).</p> <p><b>Published</b> With international search report. Before the expiration of the time limit for amending the claims and to be republished in the event of the receipt of amendments.</p>	

(54) Title: IMPROVED FIXING ANCHOR

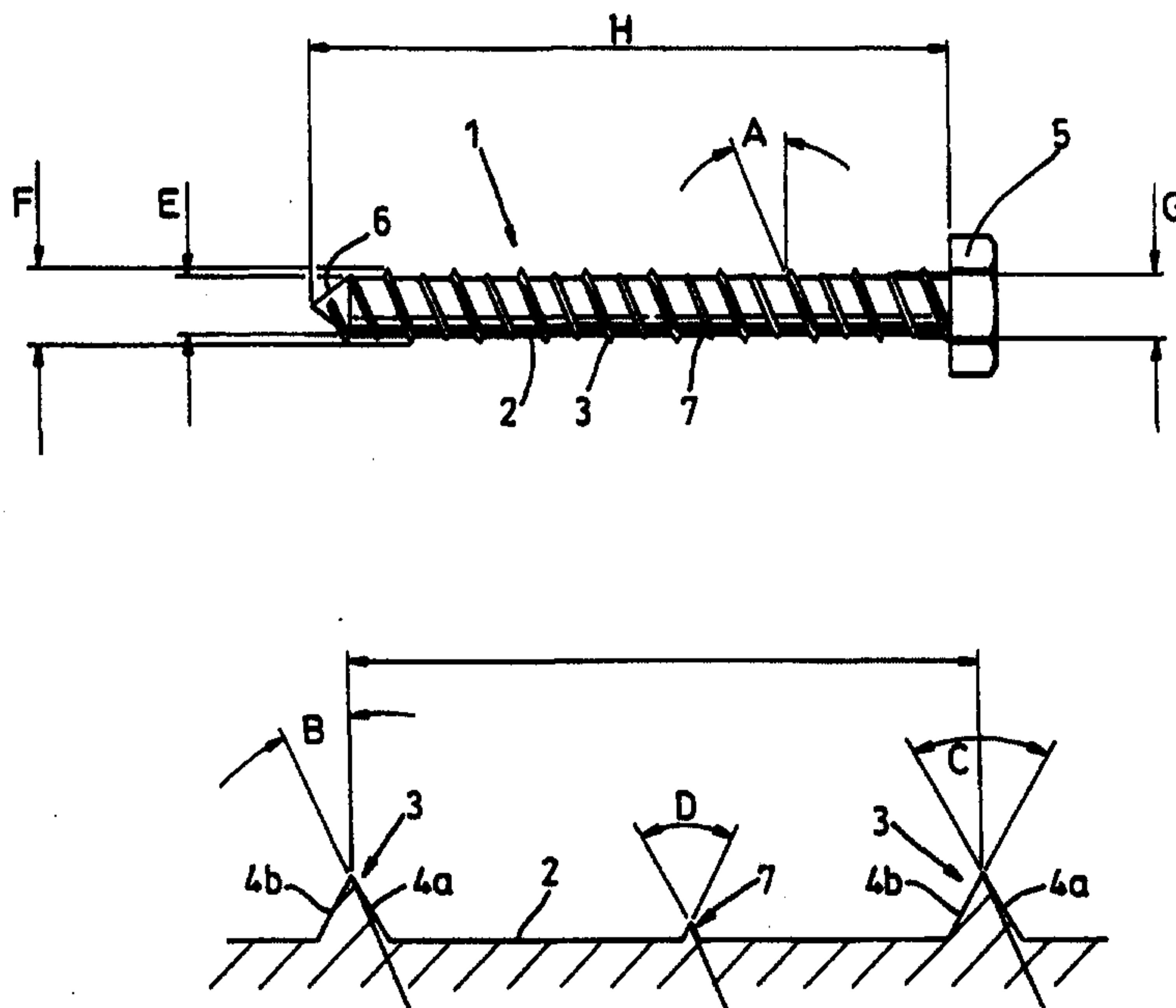

(57) Abstract

A threaded fastener (1) is disclosed for anchoring into a substrate comprising a core portion (2) having at least one helical continuous thread provided along a substantial portion of the length of the core, in which the helical thread has a substantially V-shaped cross section defining two flanks (4a, 4b) which subtend an angle of between substantially 60° and 90°, and the thread has a helix angle of between approximately 20° and 45°. The crest of the thread may be flattened, and the fastener (1) is especially suited to anchoring to a masonry substrate.

**IMPROVED FIXING ANCHOR**

This invention relates to improvements in fixing anchors, in particular threaded fasteners for fixing into brick, blocks, masonry or the  
5 like.

It is well known that with the exception of resin anchors, fixing anchors for use by the construction industry or hobbyists are generally designed to work in specific substrates such as concrete or masonry. One  
10 well known method for fixing to relatively hard and/or brittle substrates such as concrete or brick or stone, is to first drill a hole in the substrate and then insert an anchor which includes an expansion mechanism. A standard screw may then be inserted within the anchor which causes the anchor to expand as it is tightened. The expansion of the anchor exerts a radially  
15 directed compressive force on the walls of the pre-drilled hole which holds the anchor in place.

An alternative method of fixing into concrete is to employ a self tapping screw. However, such a fixing is suitable where only light loads  
20 are to be carried by the fixing, and is not well suited to soft substrates.

According to a first aspect of the invention, a threaded fastener for anchoring into a substrate comprises a core portion having at least one helical continuous thread provided along a substantial portion of the length  
25 of the core, in which the helical thread has a substantially V-shaped cross section defining two flanks which subtend an angle of between  $60^\circ$  and  $90^\circ$ , and the thread has a helix angle of between approximately  $20^\circ$  and  $45^\circ$ , and characterised in that the two flanks meet at a crest which is rounded.

The helix angle between  $20^\circ$  and  $45^\circ$  allows the fastener to be inserted into the substrate with a small number of turns compared to a small helix angle of, say,  $5^\circ$  to  $10^\circ$ . The choice of  $60^\circ$  to  $90^\circ$  for the thread ensures that tensile forces applied along the axis of the fastener are directed  
5 into the substrate at an angle well away from the axis providing good tensile performance in soft substrates and indeed across a wide range of substrates.

The threaded fastener is suitable for use with any substrate, but is most preferably used for fastening in relatively soft substrates such as brick  
10 or blockwork, sand stone or lime stone.

Most preferably, the helix angle of the thread is  $25^\circ$ .

A flat/radius for the crest of 0.01-0.015 inches is preferred.  
15

An advantage of the provision of only a single helical thread is that it provides a reduced insertion torque when compared to the provision of a dual thread. Also, a dual thread offers a reduced distance between the threads for any given helix angle which is disadvantageous.  
20

Preferably, the ratio of the outside diameter of the thread to the pitch of the thread is substantially within the range 0.5 to 0.9. This ensures good levels of performance in soft substrates.

25 Preferably, the ratio of the outside diameter of the thread to the inside diameter of the thread (i.e. the outside diameter of the core) is substantially in the range 1.25 to 1.5. Thus, the diameter of the thread is

quite large compared to the diameter of the core, which ensures that the fastener remains fast within the substrate under large tensile loads.

5 The threaded fastener may further include a secondary balancing thread which may be located in between the turns of the first helical thread. This thread can help guide the fastener when inserting into a pre-drilled hole, and may be chosen to have a diameter approximately equal to the hole diameter whilst the core is slightly smaller in diameter than the hole. The crest of the secondary thread may be flattened or rounded.

10

Preferably, the core portion is substantially smooth and cylindrical over a substantial portion of its length other than the provision of the first (and optional second) helical threads. Thus, no grooves are provided at the join between the sides of the thread and the shank which could clog  
15 with loose debris during installation.

The two flanks of the first and/or second threads may subtend equal angles with the core. Alternatively, the angle between one thread flank and the core and the other thread flank and the core may be different  
20 provided the angle subtended by the two flanks is in the range  $60^\circ$  to  $90^\circ$ .

A bolt head or other head form (such as a stud, hook or eye) may be provided on one end of the core which has a hexagonal outline for engagement with a suitably shaped insertion tool.

25

The other end of the core may finish at a point or taper, and may be provided with one or more axially extending grooves spaced around the circumference of the core. The first and/or second threads may extend to a point or taper at the tip of the core to facilitate self-tapping of the

fastener into the substrate. These notches help to facilitate ease of thread cutting in harder substrates.

5 A method of inserting the fastener according to the first aspect into a substrate may comprise pre-drilling a hole having a diameter greater than the core of the fastener but smaller than the outside diameter of the main thread and inserting the fastener into the hole. When a secondary thread is also provided, the diameter of the pre-drilled hole may be slightly smaller than or substantially equal to the outside diameter of the secondary thread. This allows the second threads to act as a guide in the hole or possibly bite into the substrate.

10 The fastener may be fabricated from a material, i.e. steel which is then hardened. This is particularly suitable for use of the fastener in relatively hard and/or abrasive substrates such as concrete. Alternatively, the fastener may be made from a plastics material, e.g. for use with aercrete substrates.

15 The fastener may be made by rolling to produce the thread or by turning or casting. The fastener may be hardened after it is produced.

20 There will now be described by way of example only two embodiments of the invention with reference to the accompanying drawings in which:

25

**Figure 1** is an illustration of a first embodiment of a threaded fastener;

30

**Figure 2** is a cross sectional view of the thread profile of the threaded fastener of Figure 1;

Figure 3 is an illustration of a second embodiment of a threaded fastener;

5 Figure 4 is an end view of the fastener of Figure 3;

Figure 5 shows a flat portion provided at the crest of the thread; and

10 Figure 6a,b,c show various possible thread cross sections.

A first embodiment of a threaded fastener is shown in Figures 1 and 2 of the accompanying drawings.

15 The fastener 1 comprises a solid elongate cylindrical core 2 having a central axis of rotation. A main thread 3 having a helical form is provided along a length of the core 2 from a point proximal a first end of the core 2 to a point proximal a second end of the core 2. A hexagonal head 5 is provided on the second end of the core to allow the fastener to  
20 be rotated using a spanner or grips, whilst the other end of the core 2 tapers to a point 6.

The core and thread are formed in one piece using a rolling die, and it is preferably made from steel. The steel is then hardened to  
25 produce a hard surface layer of approximately 0.008"-0.012".

The main thread 3 provided on the core has a helix angle A of between substantially 20 and 45 degrees, and preferably 25 degrees. The dimensions of the fastener are such that the ratio of the outside diameter F

6

of the thread to the outside diameter E of the core is between 1.25 and 1.5.

The ratio of the outside diameter of the thread F to the pitch of the  
5 thread is between 0.5 and 0.9 approximately, and the two sides 4a, 4b of  
the thread subtend an inclusive angle of between substantially  $60^\circ$  and  $90^\circ$   
and preferably  $60^\circ$  approximately. This ensures that when a tensile load  
is applied to the fastener it causes it to lock into place in the substrate  
rather than fracturing the surrounding substrate. A flat portion 8 may be  
10 provided at the crest of the thread as shown in Figure 5. The flat  
portion 8 is preferably for use with harder substrates such as concrete  
with flint aggregates. In hard substrates, a sharp crest may become  
burred or damaged which could remove the hard outer surface causing the  
required insertion force to rise or failure to cut a clean thread.

15

In addition to the first thread 3 a second thread 7 is provided which  
is disposed in between the first thread 3 and is also of a helical, spaced  
form. The second thread 7 has an outside diameter G smaller than the  
outside diameter F of the first thread 3 and acts as a guide to ensure the  
20 bolt is accurately guided during insertion into a hole in the substrate. The  
ratio of the outside diameter of the first thread 3 to the second thread 7 is  
between 1.05 and 1.2 with the two sides of the second thread subtending  
an angle of substantially  $60^\circ$ .

25

It is envisaged that several size fasteners can be manufactured and  
the fastener shown in the accompanying figures has a length H of  
approximately 100mm, with the core diameter being between 7.5mm and  
7.6mm. This allows the fastener to be inserted into a 8mm predrilled  
hole made using a masonry/hammer drill. Of course, larger and smaller  
30 fasteners are possible within the scope of the invention, up to 20mm core

7

diameter or larger being possible. Tensile loads of up to and in excess of 2 tonnes may be carried by the fixing, depending on dimensions chosen.

5 An alternative embodiment 100 is shown in Figures 3 and 4 of the accompanying drawings.

10 The fastener comprises a core 101, a main thread 102, a second thread 106 and a head 103 which correspond to the core 2, main thread 3 and second thread 7 and head 5 of the first embodiment. In this embodiment, a number of grooves 104 which run from a point adjacent the first end of the core 101 in an axial direction along the length of the core 101 are provided. The grooves 104 may have a U-shaped or V-shaped cross-section or other cross-section and help the fastener 100 to cut a thread as opposed to forming a thread. In addition, or alternatively, the grooves may run along the length of the fastener to define a plurality of notches 107 in the thread 102. These notches 107 help to allow dust and other debris to escape as the thread cuts into the substrate. The notches may only be in the thread and not penetrate the core of the fastener.

15 This helps to substantially eliminate any radial or axial stresses which may otherwise be imposed into the surrounding substrate.

25 Figure 6 is an illustration of the possible variations in thread cross-section which are envisaged within the scope of the invention. In Figure 6(a), the two flanks 4a,4b of the thread 3 subtend identical angles with the core 2. In Figures 6(b) and 6(c), the flanks subtend unequal angles so that the thread cross section is no longer symmetrical.

**CLAIMS:**

1. A threaded fastener (1) for anchoring into a substrate comprising a core portion (2) having at least one helical continuous thread (3) provided along a substantial portion of the length of the core portion, the helical thread (3) having a substantially V-shaped cross section defining two flanks which subtend an angle of between substantially  $60^\circ$  and  $90^\circ$ , and the thread (3) has a helix angle of between approximately  $20^\circ$  and  $45^\circ$ , and characterized in that the two flanks meet at a crest which is rounded.
2. A threaded fastener (1) according to claim 1 characterised in that the helix angle of the thread is  $25^\circ$ .
3. A threaded fastener according to claim 1 or claim 2 characterised in that the crest has a radius of 0.01 inches to 0.015 inches.
4. A threaded fastener according to any one of claims 1 to 3 characterised in that the ratio of the outside diameter of the thread to the pitch of the thread is substantially within the range 0.5 to 0.9.
5. A threaded fastener according to any one of claims 1 to 4 characterised in that the ratio of the outside diameter of the thread to the inside diameter of the thread is substantially in the range 1.25 to 1.5.
6. A threaded fastener according to any one of claims 1 to 5 which is characterised by further including a secondary balancing thread located in between the turns of the helical thread.
7. A threaded fastener according to claim 6 characterised in that the crest of the secondary thread is flattened or rounded.
8. A threaded fastener according to any one of claims 1 to 7 characterised in that the core

portion is substantially smooth and cylindrical over a substantial portion of its length other than the provision of the helical thread.

9. A threaded fastener according to any one of claims 1 to 8 characterised in that the two flanks of the helical thread subtend equal angles with the core portion.

5 10. A threaded fastener according to claim 6 or claim 7 characterised in that the two flanks of the secondary thread subtend equal angles with the core portion.

11. A threaded fastener according to any one of claims 1 to 10 characterised in that the angle between one thread flank and the core portion is different to that of the second thread flank to the core portion whilst the angle subtended by the two flanks is in the range  $60^\circ$  to  $90^\circ$ .

10 12. A threaded fastener according to any one of claims 1 to 11 characterised in that a head form is provided on one end of the core portion which has a hexagonal outline for engagement with a suitably shaped insertion tool.

13. A threaded fastener according to claim 12 characterised in that the other end of the core portion finishes at a point or taper.

15 14. A threaded fastener according to claim 13 characterised in that said other end of the fastener is provided with one or more axially extending grooves spaced around the circumference of the core portion.

15. A threaded fastener according to any one of claims 1 to 14 characterised by being fabricated from a material which is then hardened.

20 16. A threaded fastener according to any one of claims 1 to 14 characterised by being made from a plastics material.

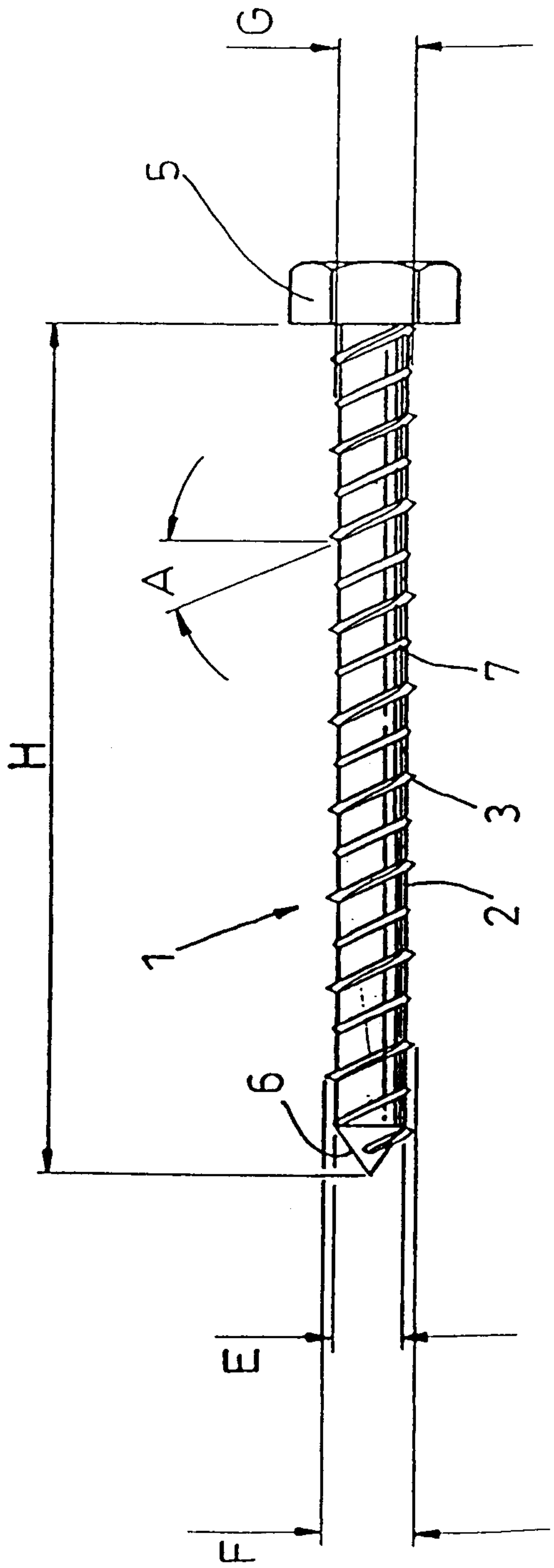

Fig. 1

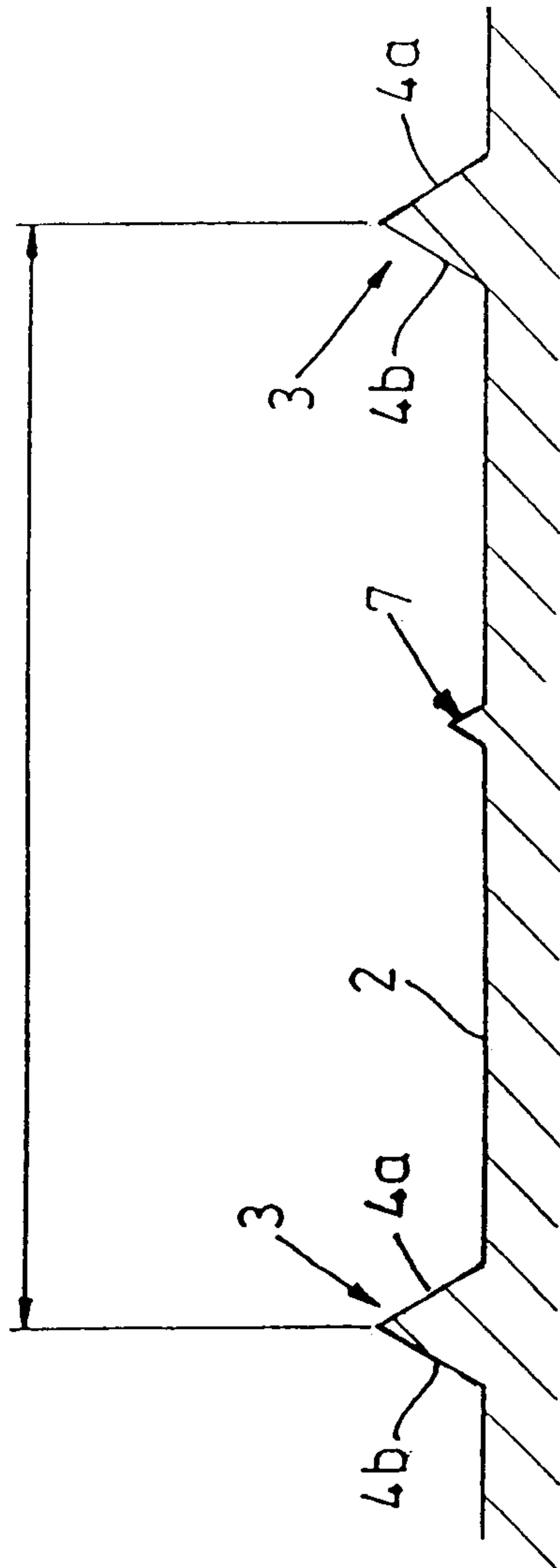
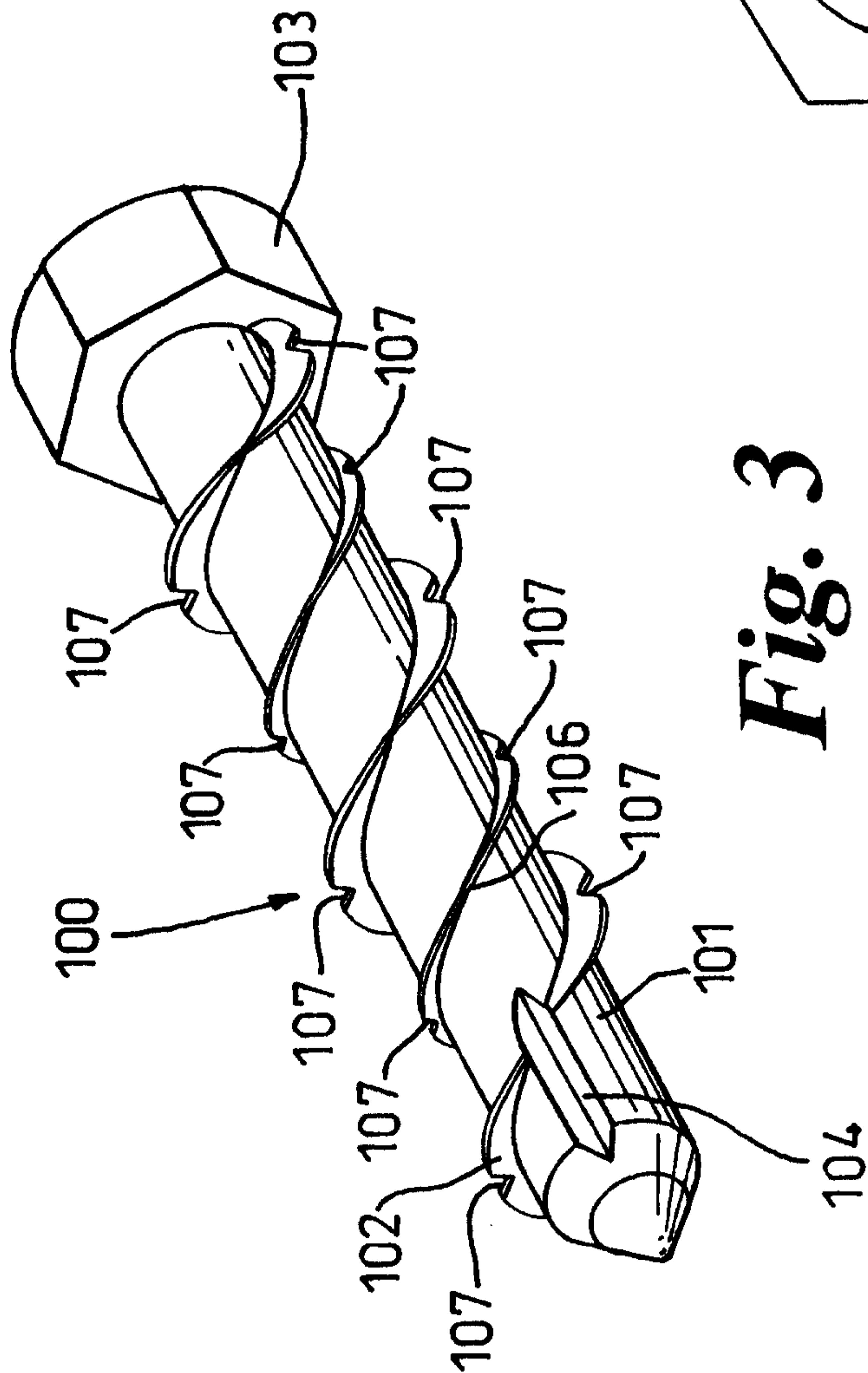
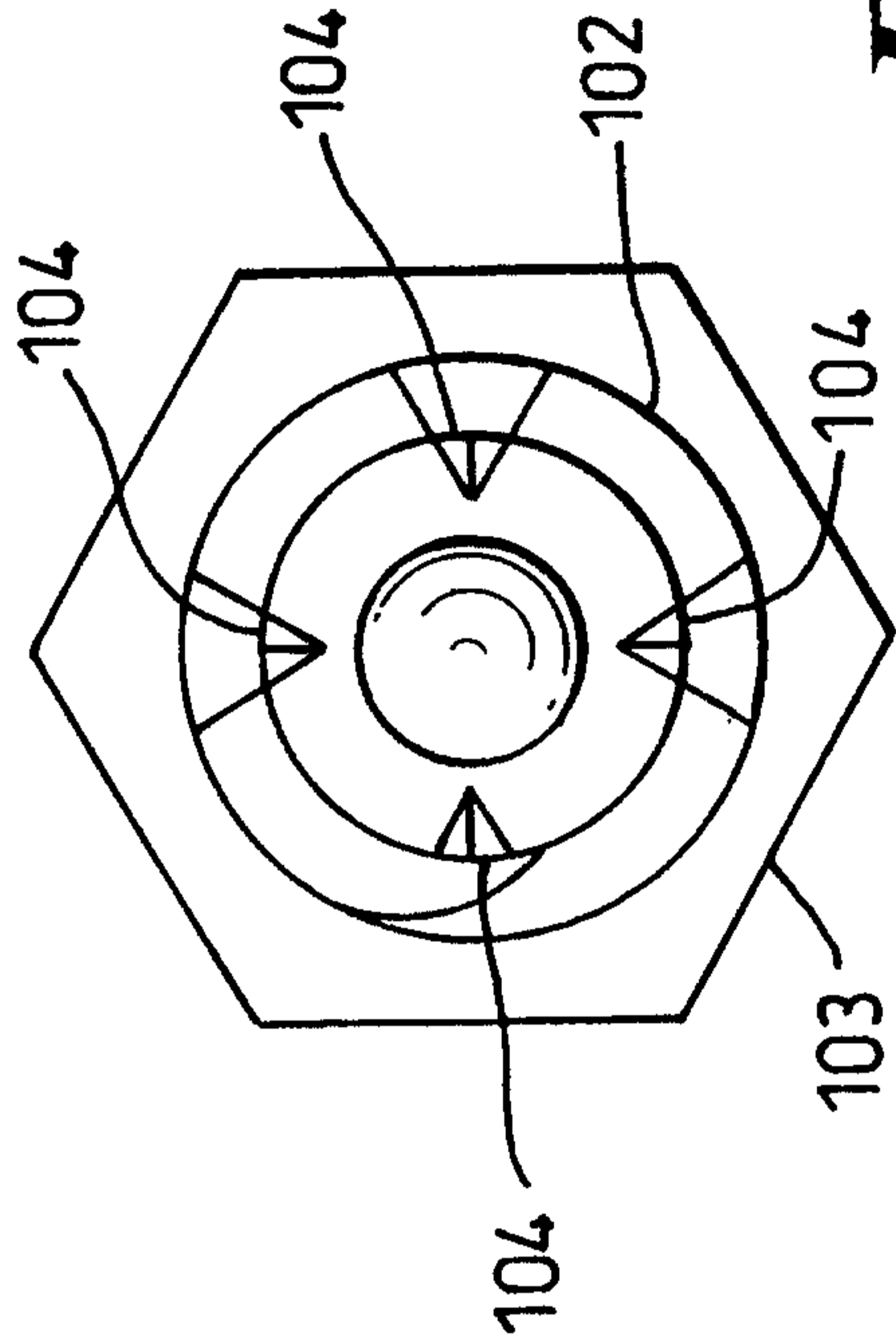

Fig. 2

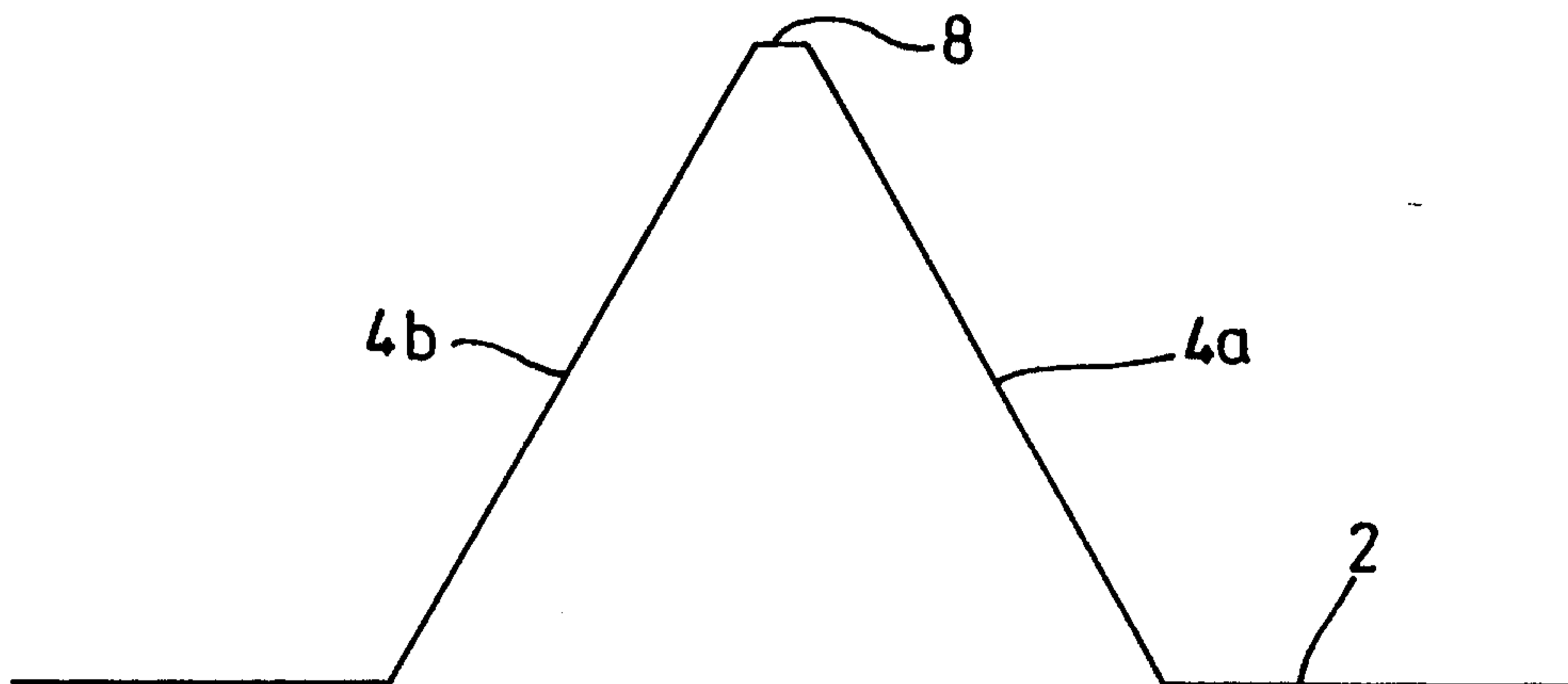

**Fig. 3**



**Fig. 4**

3/3



**Fig. 5**



**Fig. 6a**



**Fig. 6b**

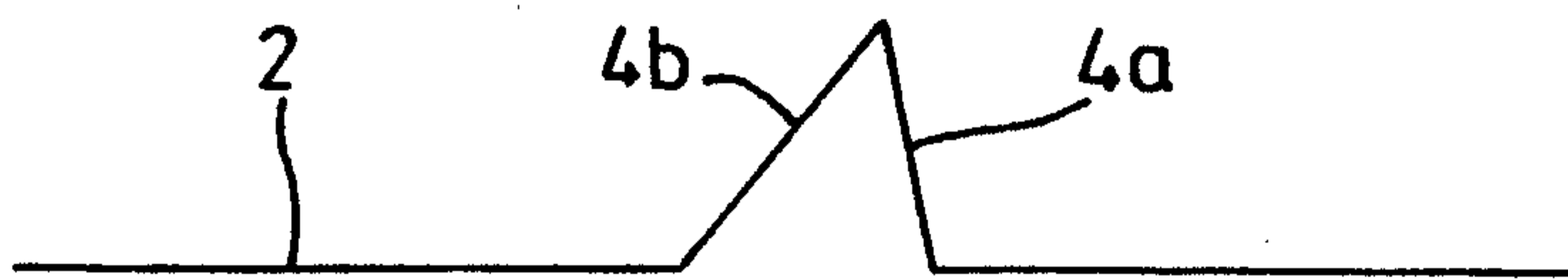

**Fig. 6c**

SUBSTITUTE SHEET (RULE 26)

