

(19)



Europäisches Patentamt  
European Patent Office  
Office européen des brevets



(11)

EP 1 635 312 A1

(12)

EUROPEAN PATENT APPLICATION

(43) Date of publication:  
15.03.2006 Bulletin 2006/11

(51) Int Cl.:  
G09F 21/04 (2006.01) G09F 15/00 (2006.01)

(21) Application number: 04104336.5

(22) Date of filing: 08.09.2004

(84) Designated Contracting States:  
AT BE BG CH CY CZ DE DK EE ES FI FR GB GR  
HU IE IT LI LU MC NL PL PT RO SE SI SK TR  
Designated Extension States:  
AL HR LT LV MK

- Kappelhoff, Rogier  
1018 MR Amsterdam (NL)
- Witte, Johannes, Hendricus  
1019 BB Amsterdam (NL)

(71) Applicant: America, Andreas Henri Gerardus  
2311 GN Leiden (NL)

(74) Representative: Metman, Karel Johannes et al  
De Vries & Metman  
Overschiestraat 180  
1062 XK Amsterdam (NL)

(72) Inventors:  
• America, Andreas, Henri, Gerardus  
2311 GN Leiden (NL)

(54) Vehicle display mounting structure

(57) A display mounting structure for a truck comprises at least a first profile section and a second profile section (7) adapted to be attached to the back doors of the truck in a position parallel to each other. The profile sections (6,7) each comprise holding means for holding a respective side of a sheet-like display (D) which is so stretched to show the image on the display at a distance from the underlying door surface.

tions (6,7) each comprise holding means for holding a respective side of a sheet-like display (D) which is so stretched to show the image on the display at a distance from the underlying door surface.

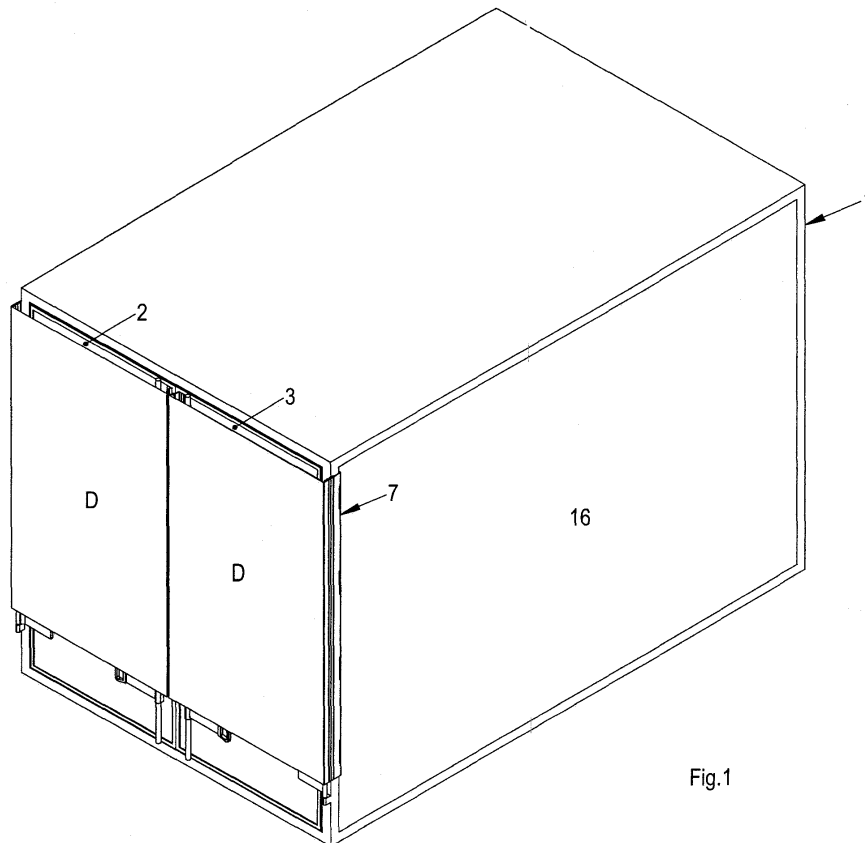

Fig.1

EP 1 635 312 A1

## Description

**[0001]** The invention relates to a display mounting structure for a vehicle, in particular a truck.

**[0002]** The most common way of displaying advertisements or other displayable representations on trucks and like vehicles is by using large stickers which are adhered to the side or the back door(s) of the vehicle. Adhering the stickers to the vehicle and especially taking them off again is a labour intensive and time consuming operation. There is also a considerable risk that the mounting surface of the vehicle or the paint thereon is damaged when the stickers are removed. In many cases the image on the sticker is interrupted by hinges or other projecting parts on the surface underlying the sticker.

**[0003]** An object of the present invention is to provide a vehicle display mounting structure by which these disadvantages are eliminated or at least reduced.

**[0004]** For obtaining this object, the invention provides a display mounting structure for a vehicle, in particular a truck, comprising at least a first profile section and a second profile section adapted to be attached to the vehicle in a position parallel to each other, said profile sections each comprising holding means for holding a respective side of a sheet-like display.

**[0005]** By using profile sections, which may be permanently fixed to the vehicle, a sheet-like display can be held and stretched on or close to the surface of the vehicle. The sheet-like display may be printed with the advertisement or other image. If the profile sections are slender or sleek, they hardly disturb the appearance of the vehicle. Changing displays means that the sides of the display are dismounted from the profile sections and a new display is mounted again by attaching the sides thereof to the profile sections. This may be a very simple operation, and there is hardly any risk of damage to the surface of the vehicle.

**[0006]** A simple and quick mounting and demounting of the sides of the sheet-like display can be obtained if the holding means of the profile sections comprises at least one longitudinal holding recess having a narrowed entrance opening in order to receive and hold a bead at the respective side of the sheet-like display.

**[0007]** In a particular embodiment, each profile section has an attachment portion for attachment of the section to the vehicle and a holding portion comprising the longitudinal holding recess at a distance from the attachment portion.

**[0008]** By this feature, the sheet-like display will be stretched at a distance from the respective surface of the vehicle so that any projection on this surface within the boundaries of the display has no effect on the appearance of the display.

**[0009]** In a preferred embodiment the second profile section comprises a plurality of holding recesses distributed along the width of the profile section.

**[0010]** Due to the presence of several holding recesses it is possible to compensate for tolerances in the dis-

play size, in the mounting position of the profiles or in the truck width, for example, by inserting the bead of the respective side of the display sheet to the holding recess that fits with the particular dimension of the sheet.

**[0011]** A preferred embodiment of the mounting structure according to the invention is adapted to be used for mounting a sheet like display to the back doors of a truck, the second profile section comprising an attachment portion and a holding portion which are connected to each other through a pivoting portion extending parallel to the at least one holding recess.

**[0012]** In this way it is possible to extend the display sheet to the respective end of the truck door, even beyond the pivoting structure thereof. By selecting a flat design of the pivoting parts of the profile section, the profile section will not interfere with the pivoting movements of the back door of the truck.

**[0013]** The invention also relates to a vehicle comprising the display mounting structure described above.

**[0014]** Further details and advantages of the invention will appear from the following description with reference to the drawings showing an embodiment of the vehicle display mounting structure according to the invention.

**[0015]** Fig. 1 is a very schematic perspective view of a truck upper structure having back doors on which the embodiment of the display mounting structure is provided.

**[0016]** Fig. 2 is a view similar to that of Fig. 2 but showing the truck with one back door in open position.

**[0017]** Figs. 3 and 4 are schematic plan/top views of the rear part of the truck in the positions of Figs. 1 and 2, respectively.

**[0018]** Fig. 5 is a side view of the first profile section in the display mounting structure according to Figs. 1-4.

**[0019]** Fig. 6 is an enlarged sectional view according to the line VI-VI in Fig. 5.

**[0020]** Fig. 7 is an enlarged side view of the second profile section in the display mounting structure according to Figs. 1-4.

**[0021]** Fig. 8 is a perspective view on the lower side of the second profile section of Fig. 7, on a slightly smaller scale.

**[0022]** Fig. 9 is an enlarged cross-sectional view according to the line IX-IX in Fig. 7.

**[0023]** Figs. 1-4 very schematically show the upper rear structure 1 of a vehicle, in particular a truck. This closed rear structure 1 can be opened by means of two back doors 2, 3, which are pivotable around substantially vertical pivots 4 fixed to the respective side of the truck upper structure 1. The back doors 2, 3 meet each other in the center of the upper structure 1 and may be locked in their closed position by means of a locking mechanism 5.

**[0024]** As is shown in Figs. 1-4, there is provided a display mounting structure on the rear side of the vehicle, comprising two first profile sections 6 and two second profile sections 7. The first profile sections 6 are fixed to the facing free ends of the back doors 2, 3 and are mount-

ed in a mirror image position. The second profile sections 7 are attached to the side of the truck adjacent the pivoting end of the respective back door 2, 3.

**[0025]** Figs. 5, 6 show the first profile section 6 in more detail. In this embodiment, the profile section is made as an extruded section, preferably made of metal, for example aluminum. It includes an attachment portion 8 adapted for fixing the section to the vehicle. In this embodiment, the attachment portion is a flat portion of the section comprising a plurality of holes 9 to allow the passage of a fastener, such as a screw. By means of these fasteners, the profile section will be fixed to a mounting surface of the vehicle. In the case of the first profile section 6, this mounting surface will be formed by the outer surface of the back doors of the vehicle.

**[0026]** Besides the attachment portion 8, the first profile section also comprises a holding portion 10, starting at right angles to the attachment portion and including at a distance from the attachment portion a holding recess 11. This holding recess 11 extends in longitudinal direction of the profile section 6 and includes a narrowed entrance opening 12. This entrance opening faces away from the attachment portion 8, in this case at an angle of substantially 135°. Substantially parallel to the entrance opening, there is a guiding edge 13 extending away from the attachment portion 8 and terminating at a distance there from.

**[0027]** The holding recess 11 is intended to hold a bead at the respective side of the sheet-like display D therein, and the guiding edge 13 is adapted to guide the display around the extremity thereof in a direction to the other (second) profile section. This means that, in the mounted condition, the guiding edge 13 points away from the other profile section (see Fig 4).

**[0028]** Figs. 7 - 9 show the second profile section 7. It again includes an attachment portion 8 and a holding portion 10, but in this case, both portions are connected to each other through a pivot 14. In fact, the attachment portion 8 includes a plurality of separate pivot blades 15, each connected to the integral holding portion 10 through their own pivot pin extending in longitudinal direction of the second profile section. The pivot blades 15 comprise holes 9 as well to allow the passage of fasteners for fixing the second profile section to a mounting surface. In this embodiment, the mounting surface for the second profile section is formed by the side surface 16 of the truck upper structure near the rear side of the truck.

**[0029]** In the embodiment shown, the holding portion 10 of the second profile section comprises a plurality of holding recesses 11, in this case four, distributed over the width of the holding portion 10 of the second profile section 7. In use, only one of the holding recesses 11 is used to hold a bead of the sheet-like display. Which holding recess is used depends on the exact width of the display. Thus, the plurality of recesses can be used to compensate for the dimensional tolerances in the display D. The holding portion 10 of the second profile section 7 also includes a guiding edge 13 extending in line with the

rest of the holding portion 10. The extent of the guiding edge will be such that in the mounted condition with the back door closed, the extremities of the guiding edges 13 of both profile sections 6, 7 will be at substantially equal distances from the surface of the back door 2, 3. As a result, the display D will be stretched at a desired distance from the surface of the respective back door 2, 3 and parallel thereof. Due to said distance, any protrusion from the back door surface, such as the locking mechanism 5 (see Figs. 1 - 4), will not interfere with the display D and the display will have a smooth plane surface when installed.

**[0030]** In use, the holding portion 10 of the second profile section 7 is kept in position with respect to the attachment portion 8 by the stretching force in the display D which keeps the display taut and holds the holding portion in its position according to Fig. 9, i.e. in a position in which the holding and attachment portions 8, 10 are parallel to each other. When the respective back door 2, 3 of the truck is opened the holding portion will be moved by the display/back door, and in the completely opened position as is shown in Fig. 4, the holding portion 10 will be pivoted substantially 180° and will be lying substantially in line with the attachment portion 8.

**[0031]** Returning to Figs. 1 - 4, there is shown a display mounting structure in use. In this embodiment, the first profile sections 6 are mounted such that in the closed position of the back doors 2, 3 the guiding edges 13 of both first profile sections near the free end of the back doors are positioned very closely together, so that the two sheet-like displays D together form a substantially uninterrupted display surface. In the embodiment shown, the displays D, extend only through a part of the height of the back doors 2, 3 such that the locking mechanisms 5 are positioned below the displays D, and do not interfere. It is however conceivable that the displays extend substantially over the entire height of the back doors. In this case, in order to be able to operate the locking mechanisms 5 of the back doors 2, 3 in an easy way, there can be made a provision in the displays D, such as a slit, to get easy access to the locking mechanisms. As an alternative, depending on the position and size of the locking mechanisms 5, the first profile sections 6 may be mounted more outwardly so that the locking mechanisms 5 will be positioned between the first profile sections 6. In that case, there will be a slight gap between the sheet-like displays D.

**[0032]** From the foregoing it will be clear that the invention provides a vehicle mounting structure which is simple, reliable and easy to mount and demount without a risk of damaging the mounting surface.

**[0033]** The invention is not restricted to the above-described embodiment as shown in the drawing, which can be varied in several ways without departing from the scope of the invention. For example, it is possible to include additional profile sections or other holding means to hold one or two of the other sides of the sheet-like display. Furthermore, the holding means of the profile

sections may be constructed differently depending on the cooperating part of the display. The number and position of the profile sections will also depend on the structure of the mounting surface of the vehicle, which may be on the back door(s) of the vehicle or on another part, such as the side thereof.

### Claims

1. A display mounting structure for a vehicle, in particular a truck, comprising at least a first profile section (6) and a second profile section (7) adapted to be attached to the vehicle in a position parallel to each other, said profile sections (6, 7) each comprising holding means (10 - 12) for holding a respective side of a sheet-like display (D). 5
2. The mounting structure of claim 1, wherein the holding means (10 - 12) of the profile sections (6, 7) comprises at least one longitudinal holding recess (11) having a narrowed entrance opening (12) in order to receive and hold a bead at the respective side of the sheet-like display (D). 10
3. The mounting structure of claim 1 or 2, wherein each profile section (6, 7) has an attachment portion (8) for attachment of the profile section to the vehicle and a holding portion (10) comprising the longitudinal holding recess (11) at a distance from the attachment portion. 15
4. The mounting structure of claim 3, wherein the holding portion (10) comprises a protruding guiding edge (13) adapted to guide and deflect the display sheet (D) towards the other profile section at a distance from the attachment portion (8), and preferably also at a distance from the holding means (10 - 12) . 20
5. The mounting structure of any one of claims 2 - 4, wherein the second profile section (7) comprises a plurality of holding recesses (11) distributed along the width of the profile section. 25
6. The mounting structure of any one of the preceding claims, adapted to be used for mounting a sheet like display (D) to the back doors (2, 3) of a truck, wherein the second profile section (7) comprises an attachment portion (8) and a holding portion (10) which are connected to each other through a pivoting portion (14) extending parallel to the at least one holding recess (11) . 30
7. The mounting structure of claim 6, wherein the attachment portion (8) is adapted to be attached to the side (16) of the truck adjacent the respective back door (2, 3), the attachment portion (8) and the holding portion (10) extending substantially parallel in the 35
8. A vehicle comprising the mounting structure according to any one of the preceding claims, the vehicle including at least one back door (2, 3), wherein the first profile section (6) is attached to the back door (2, 3) near the opening side thereof and the second profile section (7) is attached to the vehicle near the pivoting side of the back door (2, 3). 40
9. The vehicle of claim 8, wherein the second profile section (7) is attached to the side (16) of the vehicle near the respective back door (2, 3). 45
10. The vehicle of claim 8 or 9, wherein the vehicle comprises two back doors (2, 3) pivoting about substantially vertical pivoting axes (4). 50
11. The vehicle of claim 10, wherein the first profile section (6) has an attachment portion (8) for attachment of the profile section to the vehicle and a holding portion (10) comprising the longitudinal holding recess (11) at a distance from the attachment portion, the holding portion (10) comprising a protruding guiding edge (13) adapted to guide and deflect the display sheet towards the other profile section (3, 2) at a distance from the attachment portion, said protruding guiding edge (13) being positioned closer to the free end of the respective back (2, 3) door than the attachment portion (8). 55
12. A vehicle comprising a display mounting structure, the vehicle including at least one back door (2, 3), wherein a first profile section (6, 7) is attached to the back door near the opening side thereof and a second profile section (7) is attached to the vehicle near the pivoting side of the back door, said profile sections (6, 7) being adapted to hold and stretch a sheet-like display (D) between the profile sections (6, 7).

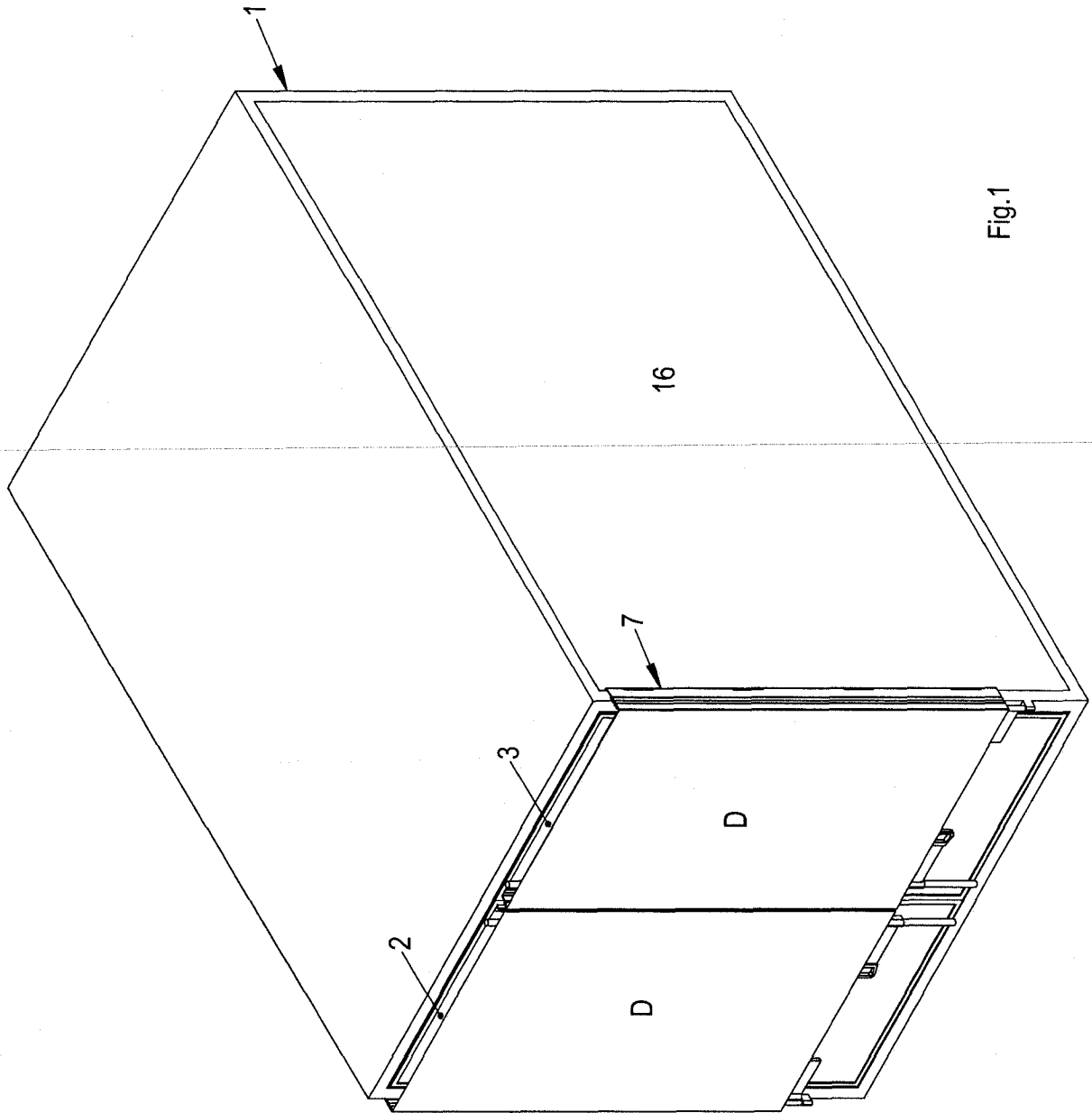

Fig.1

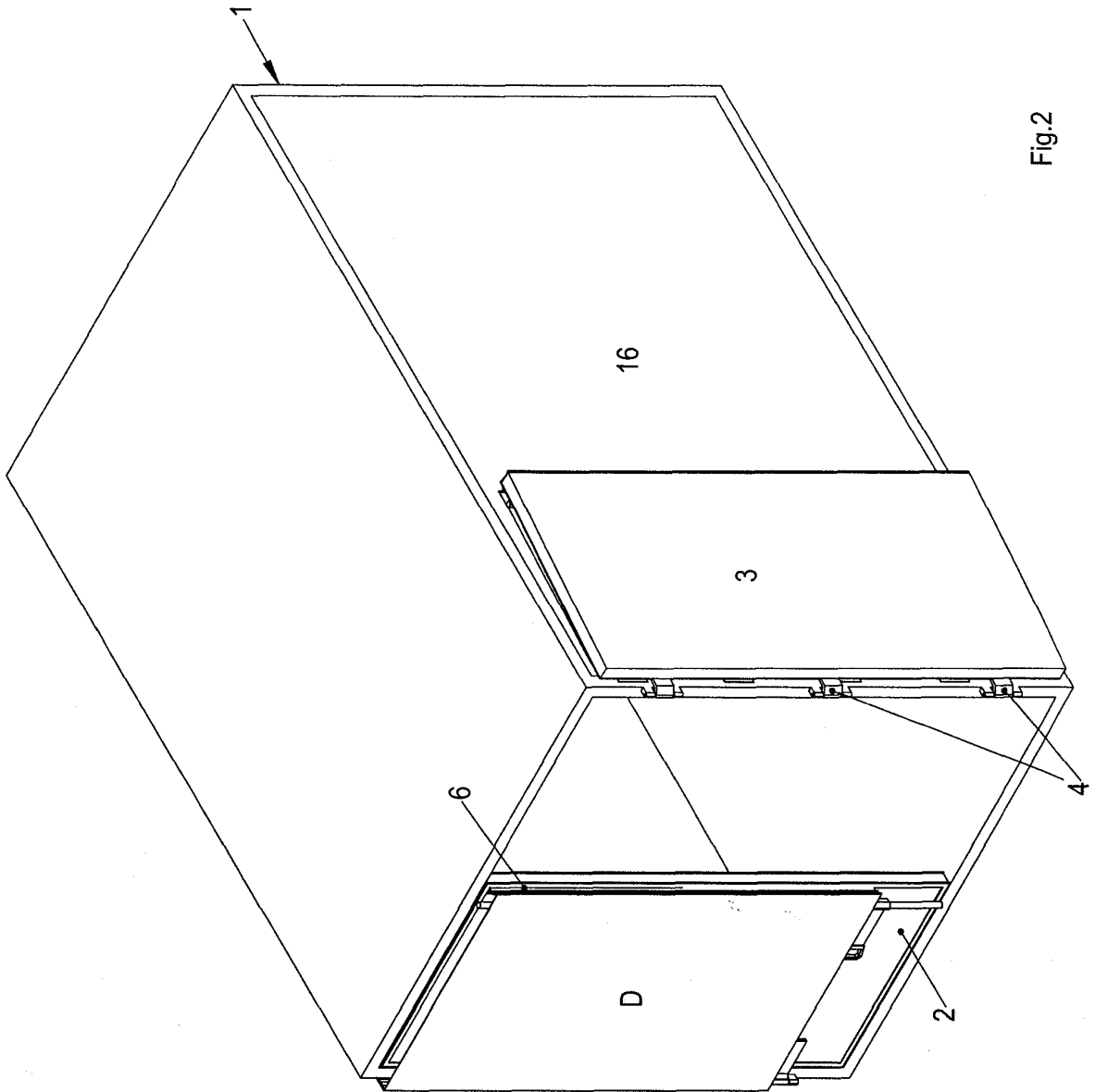

Fig.2

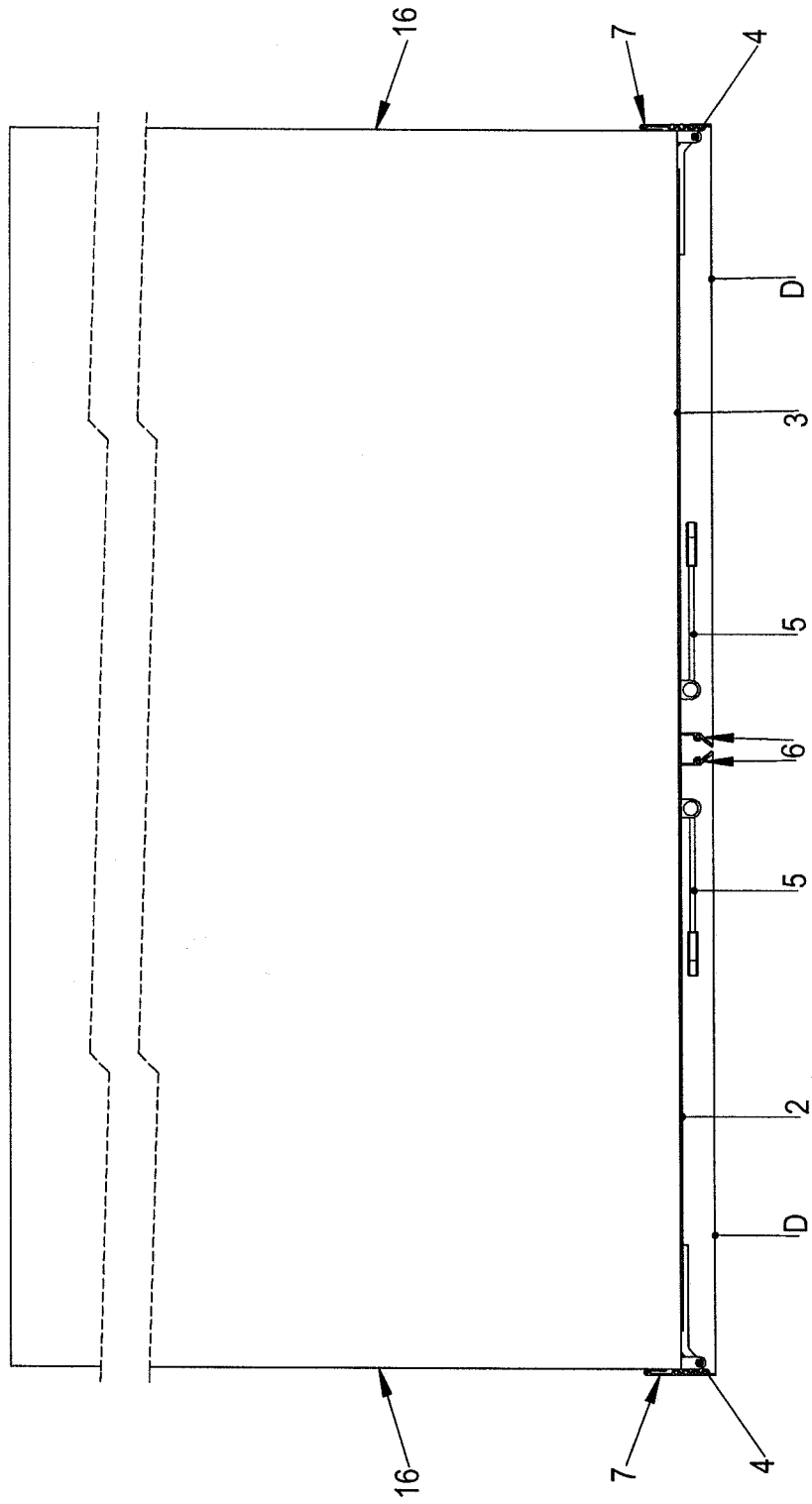

Fig.3

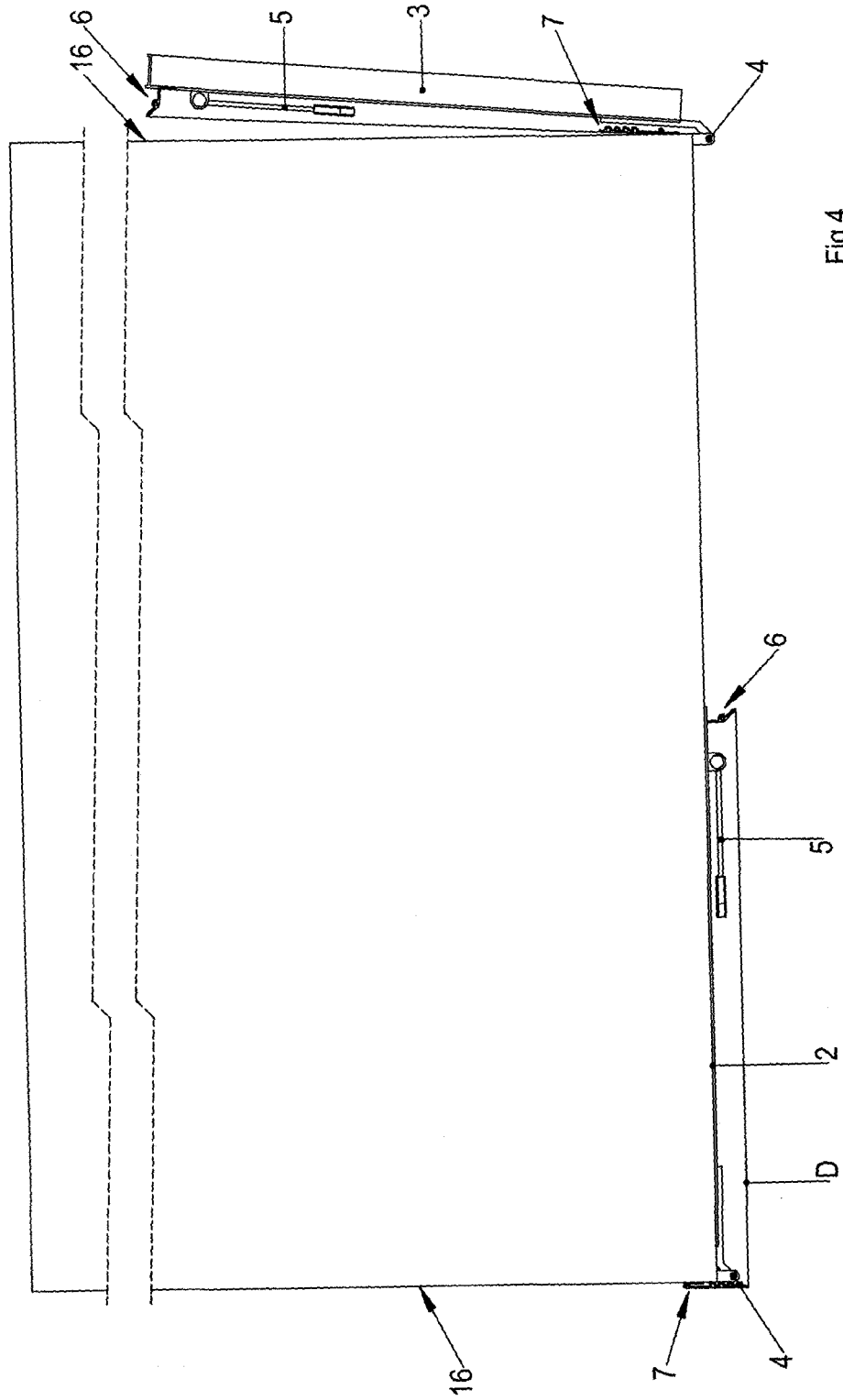

Fig.4

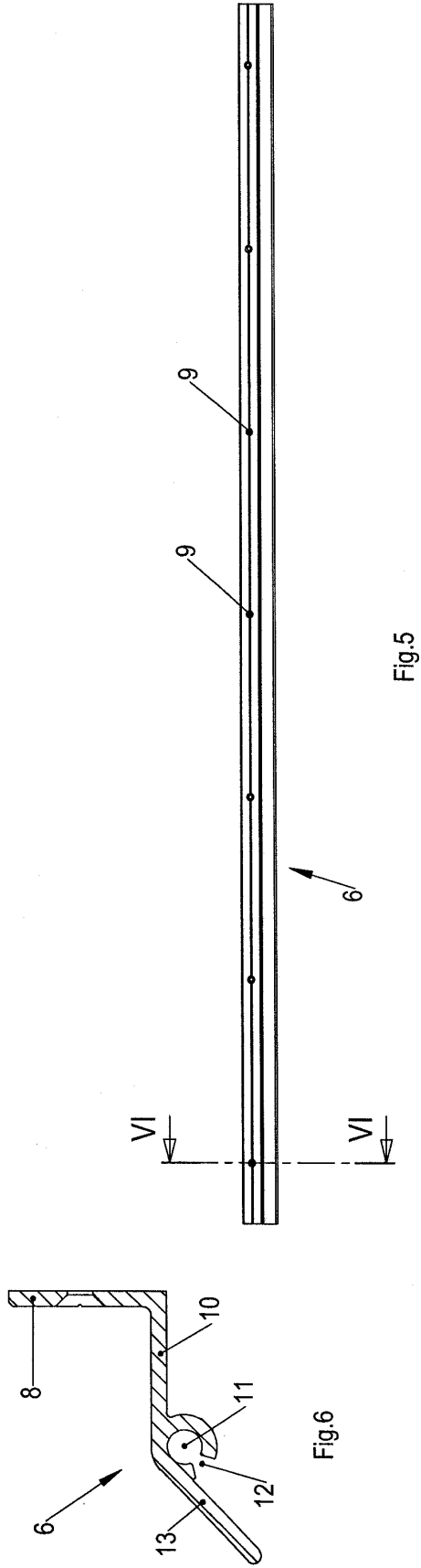
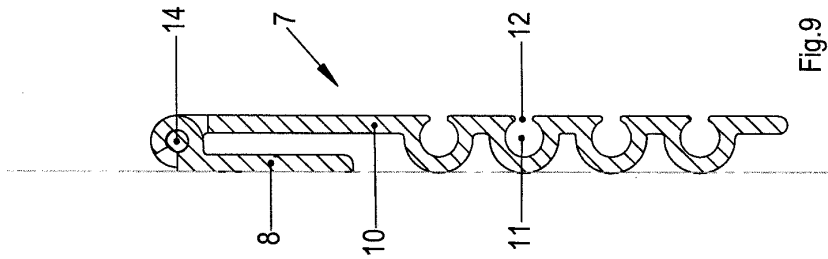
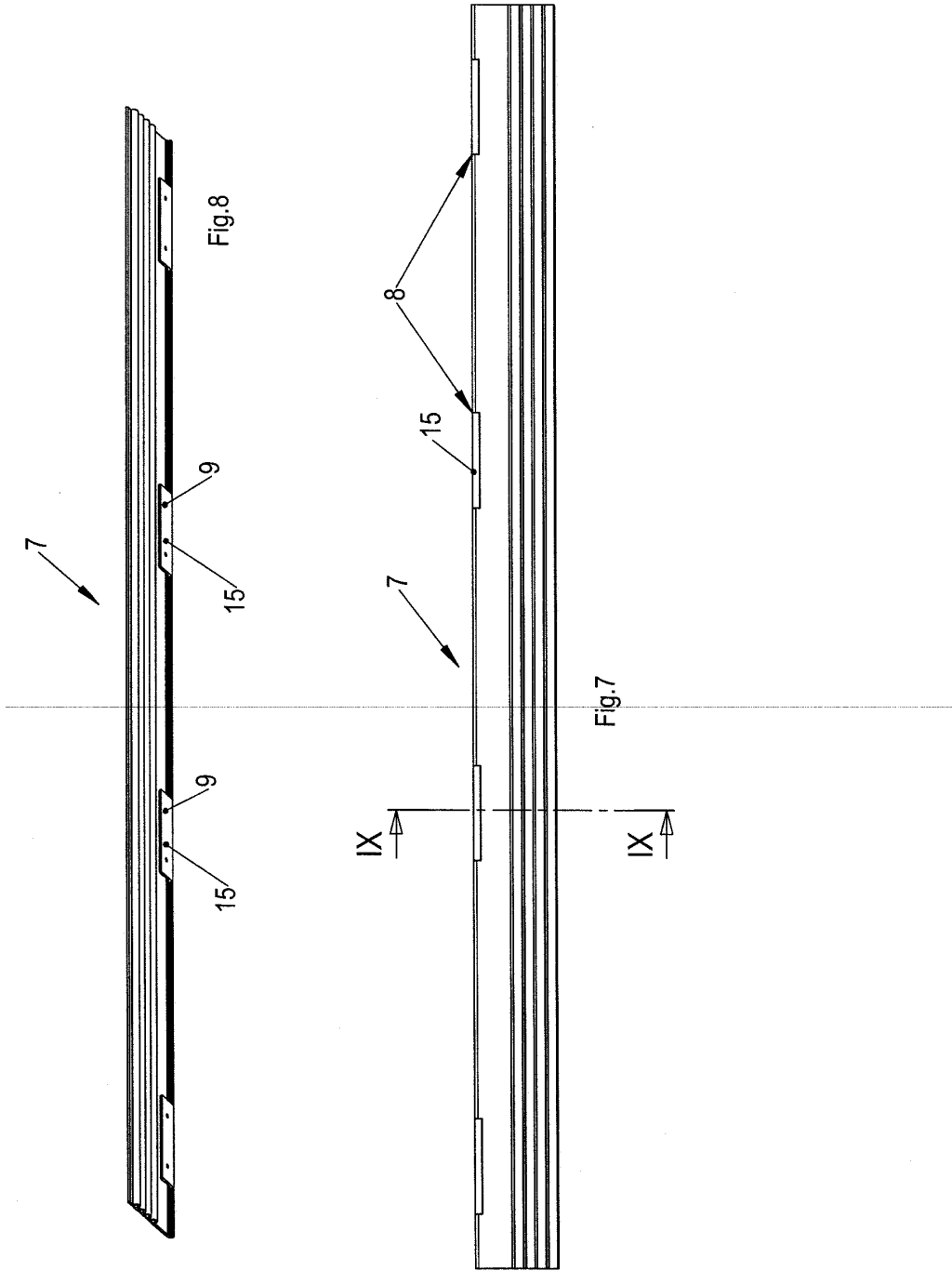

Fig.5

Fig.6





DOCUMENTS CONSIDERED TO BE RELEVANT			
Category	Citation of document with indication, where appropriate, of relevant passages	Relevant to claim	CLASSIFICATION OF THE APPLICATION (Int.Cl.7)
X	WO 98/55981 A (WITTENBERG, RON, LEO) 10 December 1998 (1998-12-10) * page 9, line 1 - line 20 * * page 10, line 2 - line 18 * * figures 4-6 *	1-4	G09F21/04 G09F15/00
X	----- EP 1 001 403 A (SCHMIDT, KEVIN) 17 May 2000 (2000-05-17) * paragraph [0017] * * paragraph [0021] * * paragraph [0026] * * figures 1-17 *	1-3,6	
A	-----	6-12	
X	US 2 724 917 A (NORFLEET CHARLES M) 29 November 1955 (1955-11-29) * column 2, line 29 - line 56 * * column 3, line 29 - line 60 * * figures 1-5 *	1,12	
A	-----	2-11	
X	EP 1 271 456 A (WITTENBERG, RON) 2 January 2003 (2003-01-02) * paragraph [0021] - paragraph [0025] * * figures 1,6-11 *	1-3,5	TECHNICAL FIELDS SEARCHED (Int.Cl.7) G09F
A	US 6 282 822 B1 (RINZLER LYONS KEITH ET AL) 4 September 2001 (2001-09-04) * column 4, line 34 - line 55 * * column 5, line 17 - line 62 * * figures 2,4,6,7 *	1-12	
A	EP 1 288 890 A (BOEJTJE, KALMAN) 5 March 2003 (2003-03-05) * paragraph [0050] - paragraph [0051] * * paragraph [0055] * * figures 1-5 *	1-12	
The present search report has been drawn up for all claims			
Place of search The Hague		Date of completion of the search 25 April 2005	Examiner Pantoja Conde, A
CATEGORY OF CITED DOCUMENTS X : particularly relevant if taken alone Y : particularly relevant if combined with another document of the same category A : technological background O : non-written disclosure P : intermediate document		T : theory or principle underlying the invention E : earlier patent document, but published on, or after the filing date D : document cited in the application L : document cited for other reasons ..... & : member of the same patent family, corresponding document	

2  
EPO FORM 1503 03.82 (P04C01)

**ANNEX TO THE EUROPEAN SEARCH REPORT  
ON EUROPEAN PATENT APPLICATION NO.**

EP 04 10 4336

This annex lists the patent family members relating to the patent documents cited in the above-mentioned European search report. The members are as contained in the European Patent Office EDP file on the above-mentioned patent application. The European Patent Office is in no way liable for these particulars which are merely given for the purpose of information.

25-04-2005

Patent document cited in search report		Publication date	Patent family member(s)	Publication date
WO 9855981	A	10-12-1998	AU 7813098 A	21-12-1998
			CA 2292951 A1	10-12-1998
			WO 9855981 A2	10-12-1998
			US 6250002 B1	26-06-2001
			US 6209245 B1	03-04-2001
-----				
EP 1001403	A	17-05-2000	DE 19852555 A1	18-05-2000
			DE 29820390 U1	18-02-1999
			EP 1001403 A2	17-05-2000
-----				
US 2724917	A	29-11-1955	NONE	
-----				
EP 1271456	A	02-01-2003	US 2002194760 A1	26-12-2002
			CA 2391730 A1	25-12-2002
			EP 1271456 A2	02-01-2003
-----				
US 6282822	B1	04-09-2001	AU 4047000 A	16-10-2000
			WO 0058590 A1	05-10-2000
-----				
EP 1288890	A	05-03-2003	EP 1288890 A1	05-03-2003
			DE 20121722 U1	24-04-2003
-----				

EPO FORM P0459

For more details about this annex : see Official Journal of the European Patent Office, No. 12/82