

Oct. 5, 1965

J. SHIFFMAN

3,209,624

TOOLS FOR REMOVING AND FITTING BACK PLATES OF WATCHES

Filed Feb. 11, 1963

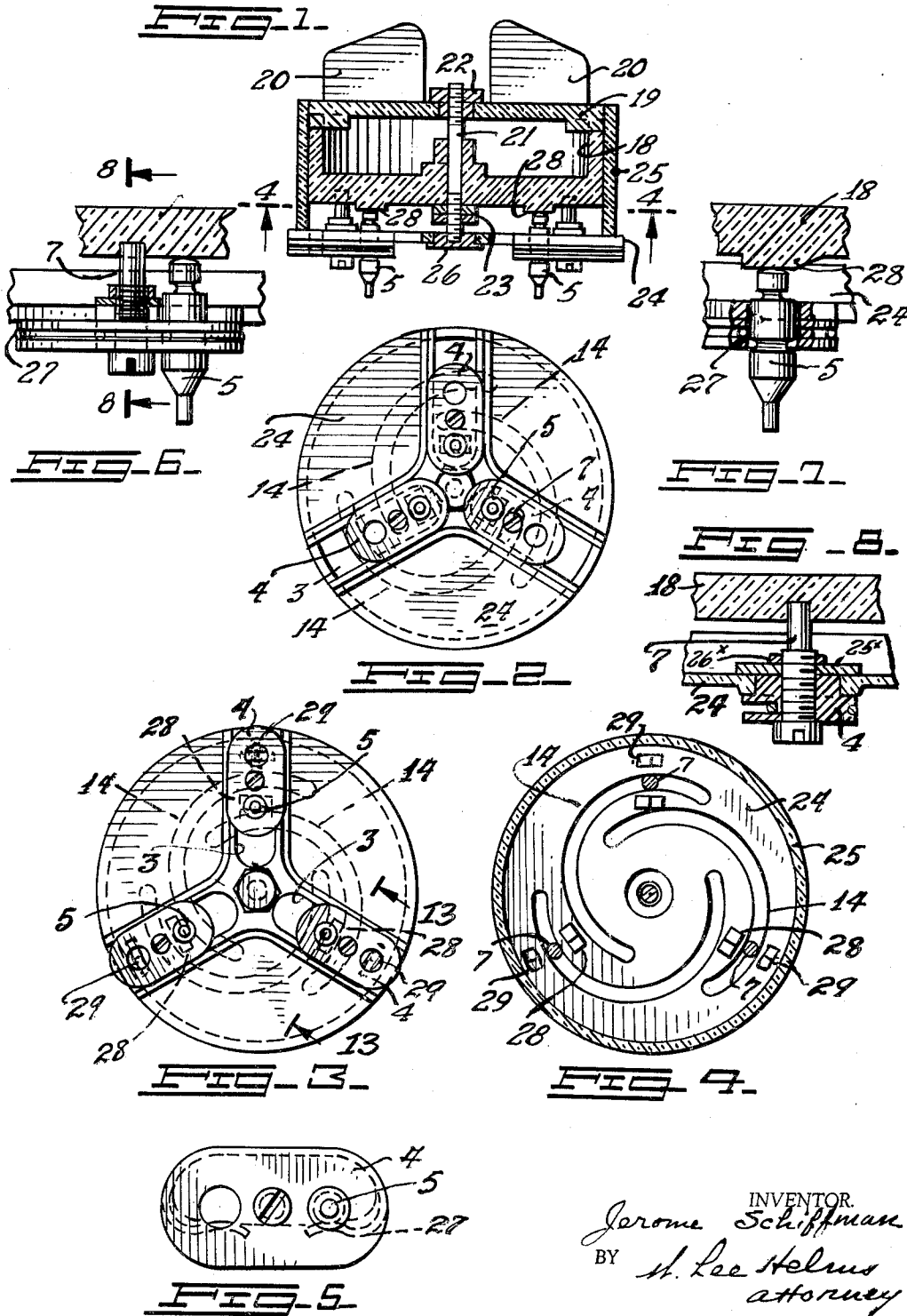

INVENTOR
Jerome Schiffman
BY *H. Lee Helms*
attorney

1

3,209,624

TOOLS FOR REMOVING AND FITTING BACK PLATES OF WATCHES

Jerome Shiffman, 128 Cartage Road, Scarsdale, N.Y.
Filed Feb. 11, 1963, Ser. No. 257,454
2 Claims. (Cl. 81-6)

This invention relates to tools for removing and fitting the back plates of watches, and which may also be employed for so handling watch crystals, particularly those which are of resilient material. The invention is particularly directed to a construction which will engage indented gripping areas of a watch back plate, and which may be rotated to remove the same.

The invention will be described with reference to the accompanying drawing, in which:

FIG. 1 is a vertical section through an embodiment.

FIG. 2 is a bottom plan view of said embodiment showing the gripping carriers moved inwardly.

FIG. 3 is a bottom plan view of said embodiment showing the gripping carriers moved outwardly.

FIG. 4 is a horizontal section taken on the line 4-4, FIG. 1, illustrating channelways in the rotor and the cams for ejecting the gripper pins.

FIG. 5 is a bottom plan view of the gripper pin carrier with one pin latched against free release by a spring, the spring being adapted to act upon two pin receiving apertures in the carrier.

FIG. 6 is an enlarged fragmentary vertical section, through the bottom wall of the rotor, showing the pin-carrier in full lines.

FIG. 7 is a fragmentary view vertical section similar to FIG. 6, showing the bottom wall of the rotor and a pin at the high point of its ejection cam.

FIG. 8 is a vertical section on the line 8-8, FIG. 6. Features of the embodiment are that the rotor is provided with a cover which carries an upstanding finger grip, a compartment in the rotor under the cover being adapted to hold gripper pins and other items as desired. In addition, the gripper element carriers are provided with apertures to receive gripper pins. The pins are spring held in position by spring 27. Also, the bottom wall of the rotor is provided with cam elements indicated at 28, so that when the rotor is turned to an extreme position, the pins are ejected by said cams.

Referring to FIGS. 1 to 8 of the drawings, I have shown at 25 a cup-like casing having a bottom wall 24, with the latter being formed with a plurality of radial slots at 3. In each slot is positioned a carrier 4 for a watch plate gripping pin 5. Each carrier 4 has an upstanding post 7 for a purpose now to be described.

At 18 is shown a rotor, which is a cup-like member positioned within the casing. The bottom of the casing is apertured to receive a nut 26 which is threaded on a shaft 21, the wall around the nut 26 being countersunk for abutment by the nut. The shaft 21 passes through the rotor and has threaded on its upper end a holding nut 22.

The bottom of the rotor 18, 19 is formed with three channelways 14, indicated more particularly in FIG. 1, each channelway receiving the post 7 of one of a plurality of gripping pin carriers. Each channelway is formed as a spiral gradually leading from the bottom wall area nearest the rim of the rotor interiorly thereof to a position nearer the axis of the rotor, so that movement of one

2

rotor in the direction will move gripper pin carriers inwardly, and a reverse action of the rotor will move the carriers with their gripper pins outwardly.

It will be seen that the rotor 18, 19 includes a removable top wall or cover having upstanding finger pieces 20 by which the rotor may conveniently be turned. The rotor cover is held in position by the shaft 21 by means of nut 22, the rotor being loosely mounted on the shaft, and it may be gravitationally supported by said washer or washers 23. As stated, the screw may be held in fixed position on the bottom wall 24 of the casing 25 by a lowermost nut 26.

The manner in which the pin carriers are slidingly supported in the radial apertures 3 of the casing bottom wall 24 will now be described. As shown more particularly in FIGURES 2 and 8, each pin carrier 4 overlaps depending ribs on the bottom wall, then passes through aperture 3, FIG. 3, and the threaded lower area of upstanding post 7 receives a plate 25x which may be held in position by a nut 26x.

Each carrier 4 may have two receiving apertures to selectively receive a gripper pin 5. Also, a lower area of each gripper pin may be slightly channeled, as indicated in FIG. 5, to receive a light latching spring 27, carried by the holder 4. Such a spring will have such light action that the gripper pin 5 may be removed or inserted, and will not obstruct the action of cam disengaging means now to be described.

In FIGURE 4 it will be noted that there are two sets of cam projections carried by said bottom wall 24 of the rotor, the first set being indicated at 28, and the second set at 29. The inner set of cam members 28 are in line with the watch plate gripping members 5, at the end of their position of release from a watch crystal, whereas the cams 29 are in line with gripper elements which may be inserted in holes of the carriers 4 which are positioned outermost therein.

When, as to each of the carriers 4, the gripper member therein is moved to extreme outward position, the appropriate cam member 28 or 29 will have engaged and have pushed outward the gripper finger from the position of FIG. 6 to released position, as shown in FIG. 7.

Having described my invention, what I claim and desire to secure by Letters Patent, is as follows:

1. A tool for removing and fitting back plates of watches, comprising a casing having a bottom wall, a plurality of slots in said bottom wall and extending radially from the center of said bottom wall, a plurality of gripper pins, a gripper pin carrier slidable in each slot and releasably holding a gripper pin, a post carried by each gripper carrier, a cup-like rotor in said casing and a removable cover therefor, said rotor holding said gripper pins in the paths of said slots, a plurality of arcuate channelways in the bottom wall of the rotor, each channelway having one end thereof at an outer area of the bottom wall of the rotor and the channelway thence continuing until the opposite end thereof lies to a greater degree near the axis of the rotor, said channelway having lateral guide walls and receiving a post of an appropriate gripper carrier, a shaft held by the casing and passing through the carrier as an axis therefor, and a plurality of cam members, one for and adjacent the path of each gripper pin at the gripper position, said cam members being carried by the rotor and moving the gripper pins outwardly of the gripper carriers when the latter are

3

moved into extreme outer positions relatively to said bottom wall of the casing.

2. A tool for removing and fitting back plates of watches, constructed in accordance with claim 1, in which the carriers of the gripping pins are channeled so that their outer wall overlies the slotted bottom wall of the casing, the carriers also having inwardly of their channels abutment means for the upper wall of the casing bottom, removal of said abutment means permitting movement of each carrier to free the carriers from the casing bottom wall.

5

10

4

References Cited by the Examiner

UNITED STATES PATENTS

562,516	6/96	Evans	81-6
1,110,173	9/14	Woodard	81-6
1,705,582	3/29	May	81-128 X
2,403,264	7/46	Cormier	81-6
2,644,354	7/53	Schlageter	81-3.42 X

FOREIGN PATENTS

912,069	7/46	France.
---------	------	---------

WILLIAM FELDMAN, *Primary Examiner.*