

No. 882,550.

PATENTED·MAR. 17, 1908.

E. D. CHELLIS.
CLOSURE FOR CONTAINING VESSELS.
APPLICATION FILED OCT. 9, 1907.

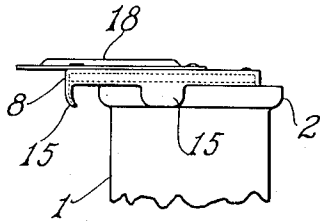

FIG. 1

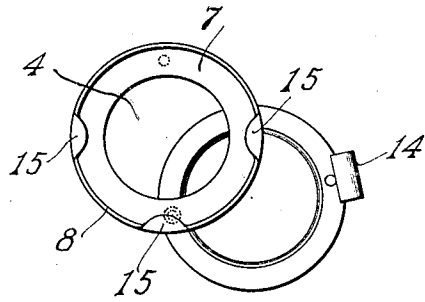

FIG. 4

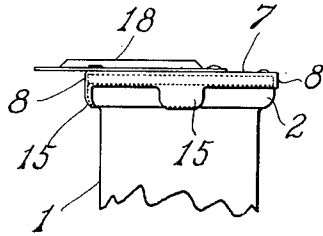

FIG. 2

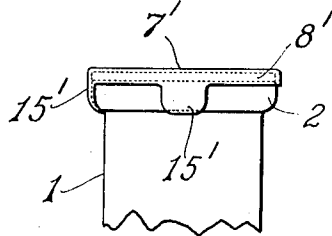

FIG. 5

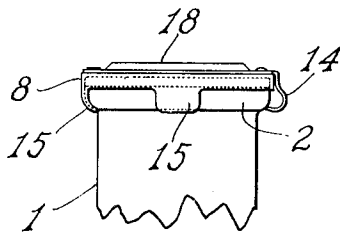

FIG. 3

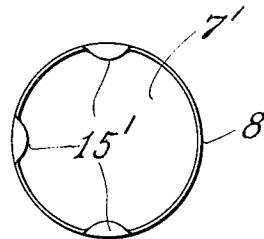

FIG. 6

WITNESSES
A. T. Palmer
L. Allen

INVENTOR
EUGENE D. CHELLIS
BY *Elli's Spear*
ATT'Y

UNITED STATES PATENT OFFICE.

EUGENE D. CHELLIS, OF PORTLAND, MAINE, ASSIGNOR TO NATIONAL METAL SEAL COMPANY, OF PORTLAND, MAINE, A CORPORATION OF MAINE.

CLOSURE FOR CONTAINING VESSELS.

No. 882,550.

Specification of Letters Patent.

Patented March 17, 1908.

Application filed October 9, 1907. Serial No. 396,532.

To all whom it may concern:

Be it known that I, EUGENE D. CHELLIS, a citizen of the United States, residing at Portland, county of Cumberland, State of Maine, have invented certain new and useful Improvements in Closures for Containing Vessels, of which the following is a specification.

The subject matter of my present invention relates to the attachment of the movable closures for containing vessels and is directed especially to the provision of means for allowing the ready adjustment of such a closure by a manual operation, without the aid of machinery or tools, by a construction which will assure a firm positioning of the closure on the bottle mouth.

In the embodiment of my invention, which I will more fully describe in the specification which follows, I have provided means for steadying the cap on the mouth of the bottle against transverse displacement and additional means to secure against longitudinal displacement, special additional means being so constructed and arranged as to allow and assist the cap proper in assuming its proper position on the mouth of the bottle and in holding it in such proper position after having been once located. I have illustrated an embodiment of these features in the accompanying drawings which form a part of the specification, in which drawings—

Figure 1 shows a cap partially positioned on the mouth of the bottle, Fig. 2 a cap in place, Fig. 3 a cap in place with the cover closed, Fig. 4 a lower plan view of such a cap, Fig. 5 a side view of a modified form of cap in place on the bottle, and Fig. 6 a plan view of the modified form of cap shown in Fig. 5.

1 is a bottle neck having its mouth sur- rounded by a shoulder 2.

Referring to Figs. 1 to 4, inclusive, 7 is a cap plate of suitable size and shape to cover the mouth of the bottle and provided with any appropriate delivery opening as 4. The plate 7 is surrounded by a depending flange 8 adapted to closely fit the outer edge of the bottle mouth and inclose the same. The flange 8 also provides a suitable recess for holding the packing which lies between the cap plate and the mouth of the bottle.

15 are clamping arms depending from the flange 8 which are adapted to engage the shoulder 2 of the bottle mouth. These arms are bent under and are formed of sheet metal so that they have a resiliency which allows

them to yield during the locating of the cap on the bottle.

18 is a cover pivoted to the cap plate at 19 and provided at its side opposite to the pivot 19 with a spring locking lip 14. The cap is applied in the following manner. The cover 18 is swung to one side and the cap applied to one side of the mouth of the bottle with the side opposite to the pivot 19 in advance. The clamping arms 15 are preferably opened so that for a portion of the circumference of the cap approximating half the cap is free from obstruction. I find it advantageous to arrange one or more clamping arms adjacent to the point of the pivot and a pair of arms oppositely located at points removable from the point of pivot by substantially a quarter circumference.

Referring to Fig. 1 it will be seen that as the cap is slid on to the bottle the side arms 15 come into engagement with the shoulder 2 first. At this point in the application of the cap the mouth of the bottle is wedging into the cap at an angle as shown in Fig. 1 and the arms 15 sprung slightly to permit the bottle to enter. As soon as the bottle mouth is pushed under the cap the arms 15 spring the depending flange 8 down over the mouth of the bottle so that a portion at least of the rim, or shoulder 2, is contained within the flange 8. The cap will then be held against any ordinary lateral or longitudinal displacement. With such a cap as shown in Figs. 1 to 4, where a transversely moving or swinging cover is employed, the locking lip 14 on the cover affords the shoulder engagement of the open side of the cap and when the cover is swung to, as shown in Fig. 3, the closure is held firmly against any transverse or longitudinal pressure which is brought to bear upon it. In some types of closures, however, for use with containing vessels to which frequent access is not needed the cap plate which I have indicated as 7¹ in Fig. 5 may be without an opening and may itself constitute the cover as well as the cap.

In the structure shown in Figs. 5 and 6, 8¹ indicates the depending flange and 15¹ the spring fingers. The application of this type of cap to a bottle is practically the same as in the forms shown in Figs. 1 to 4, the only difference being that when the cap is sprung into place the closure is complete as there is no separate cover to be brought into posi-

- tion. As stated above, this type of cap is only intended for such vessels or bottles as need only occasionally be opened or which do not need to be sealed with extreme tightness or withstand great pressure while the form shown in Figs. 1 to 4, inclusive, is adapted to use where more frequent access is required and more pressure is to be withstood.
- 10 Various modifications may obviously be made in the type of cover and in the form and arrangement of the spring arms as well as in other details of structure without departing from the spirit of my invention.
- 15 What I therefore claim and desire to secure by Letters Patent is:
1. A closure for a containing vessel having a shoulder about its mouth comprising a cap, a depending flange about said cap and oppositely disposed spring shoulder engaging fingers on said cap, and adapted to draw said flange down over the vessel mouth when the cap is laterally slid thereon.
2. A closure for a containing vessel having a shoulder about its mouth comprising a cap having a delivery opening therein, a pair of oppositely disposed shoulder engaging fingers on said cap, a laterally movable cover on said cap, a shoulder engaging lip on said cover and adapted to be disposed between

said fingers when the cover is in closed position.

3. A closure for a containing vessel having a shoulder about its mouth comprising a cap, a depending marginal flange entirely about said cap and a pair of oppositely disposed spring shoulder engaging fingers on said cap and adapted to draw said flange down over the vessel mouth when said cap is laterally slid thereon.

4. A closure for a containing vessel having a shoulder about its mouth comprising a cap having a delivery opening therein, a depending marginal flange entirely about said cap, a pair of oppositely disposed spring shoulder engaging fingers on said cap and adapted to draw said flange down over the vessel mouth when said cap is laterally slid thereon, a laterally movable cover on said cap and a shoulder engaging lip on said cover and adapted to be disposed between said fingers when the cover is in its closed position.

In testimony whereof, I affix my signature in presence of two witnesses.

EUGENE D. CHELLIS.

Witnesses:

GERRY L. BROOKS,
ERNEST O. CHELLIS.