

S. D. TILLMAN.

Improvement in Reciprocating-Engines.

No. 129,694.

Patented July 23, 1872.

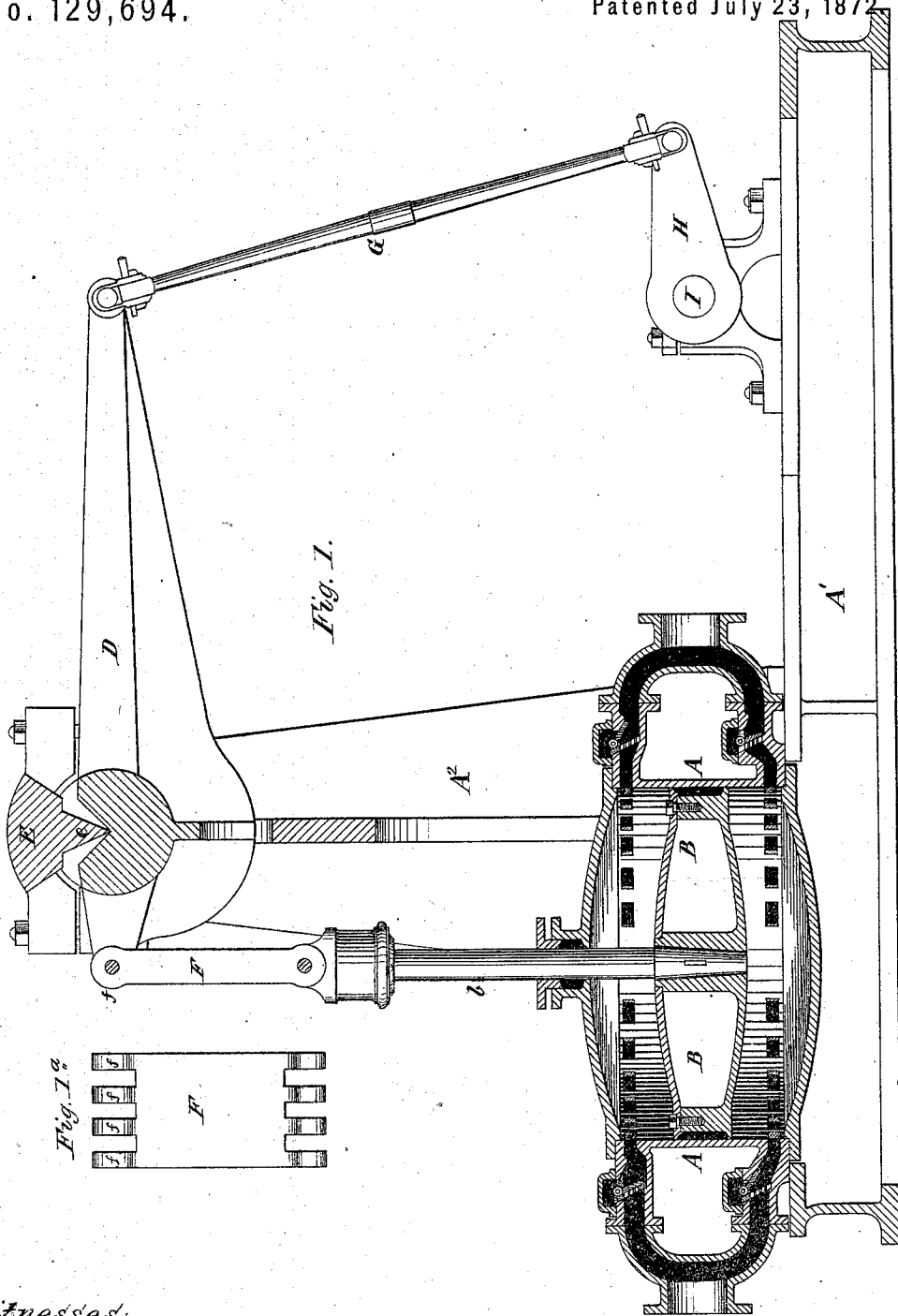

Fig. 1.

Witnesses:

J. C. Brecht.

C. E. Duffy

Inventor:

Samuel D. Tillman  
by his attorney, J. L. Stetson

S. D. TILLMAN.

Improvement in Reciprocating-Engines.

No. 129,694.

Patented July 23, 1872.

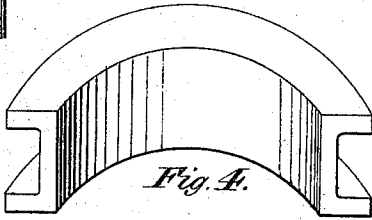
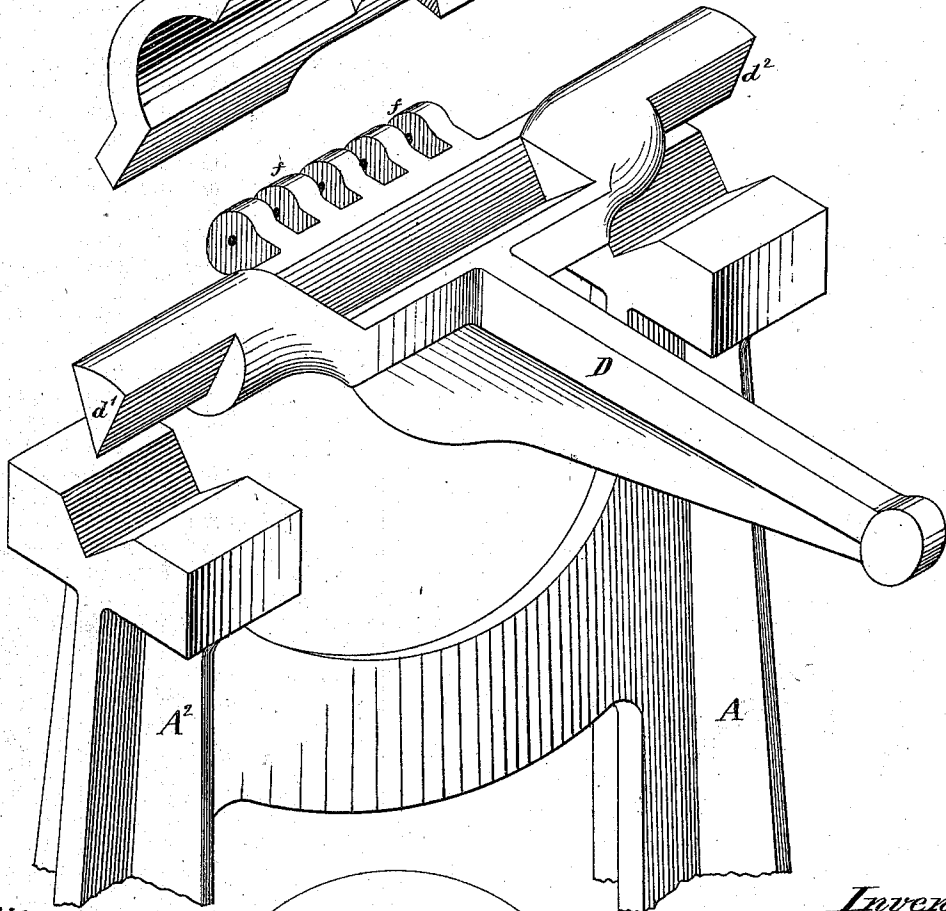
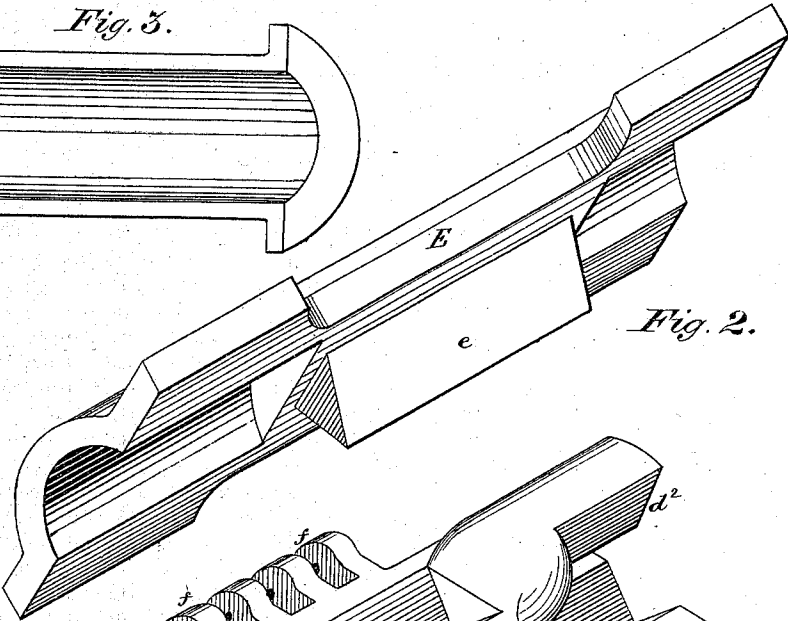
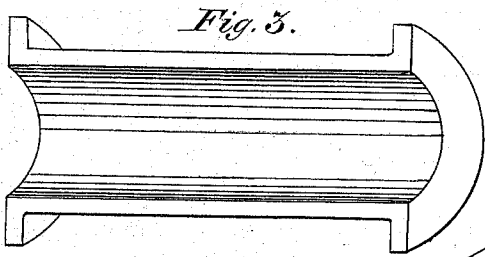

Witnesses:  
*J. C. Brecht.*  
*O. E. Duffy*

*Inventor:*  
*S. D. Tillman*  
*J. S. Wilson*

# UNITED STATES PATENT OFFICE.

SAMUEL D. TILLMAN, OF JERSEY CITY, NEW JERSEY.

## IMPROVEMENT IN RECIPROCATING ENGINES.

Specification forming part of Letters Patent No. 129,694, dated July 23, 1872.

Specification describing an Improvement in Steam-Engines, applicable, also, to pumps where a reciprocating is connected with a rotatory motion, invented by SAMUEL D. TILLMAN, of Jersey City, in the State of New Jersey.

The invention is intended for small engines and pumps, where the friction, when the parts are fitted with sufficient tightness to make permanent and practical work, becomes a very important element.

I will confine myself, mainly, to describing the steam-engine. It will be understood that in air or gas engines, pumps, and probably other apparatus, the same construction may be employed and the same advantages may be realized. A certain amount of pressure is necessary to maintain a proper tightness of fit between the piston and the interior of the cylinder. This involves friction, and with any ordinary packing it involves a considerable resistance from this cause. In proportion as the engine is enlarged the friction becomes of less and less importance; but in reducing the size of the engine it is possible to attain such a reduction that the friction will prevent its working unless correspondingly reduced by the introduction of delicacies in the adjustment which would require a constant attention.

The object of this invention is to allow the packing to be set up with ordinary force, and to wear for an ordinary period, or longer, if possible, than usual, and yet to render practicable the employment of engines of very small power and requiring a correspondingly small consumption of steam. As one fundamental step toward the attainment of this end, I increase the proportion of the diameter to the length of the cylinder. I give a very large area to the piston, with a very short stroke, and multiply the motion by means of an unequal beam. The laws by which the resistance due to the friction is thus lessened are too well known to require elucidation. A small piston, traversing in a long cylinder like a gun-barrel, involves very much more frictional rubbing of the piston and cylinder than one of corresponding volume contracted in length and expanded in diameter, like a blacking-box. It is easy in practice to efficiently clothe the extended cylinder-ends and prevent loss of heat. So far as yet described my invention

involves only an exaggeration of proportions which have been before approximated to. I have rendered a very great exaggeration practicable and highly beneficial by certain features of construction which I have applied in combination. These features have been known before in other and different combinations.

I connect the extended piston to the short arm of the beam by wide knuckle-joints, which allow the employment of small pins, and involve but slight friction in transmitting the relatively great force employed, and I mount the unequally-divided beam on knife-edges, so arranged that the strain in both directions is received on bearings which involve no friction and little necessity for lubrication or attention.

The following is a description of what I consider the best means of carrying out the invention.

The accompanying drawing forms a part of this specification.

Figure 1 is a central vertical section through the cylinder and piston, and also through a part of the beam near the central line, with an elevation of the crank and the other parts. Fig. 1<sup>a</sup> is an additional view of the connecting-link between the piston-rod and the beam. It will be understood that any ordinary means not represented may be employed for guiding the cross-head or upper end of the piston-rod. Fig. 2 is a perspective view, on a larger scale, of certain portions of the mechanism detached.

Similar letters of reference indicate like parts in both the figures.

Figs. 3 and 4 are merely graphic illustrations. They represent perspective views of halves of two cylinders of equal capacity, one of which is short and of the proper proportion for my invention, and the other is of the ordinary proportions for ordinary steam-engines.

It will be seen, from the construction and arrangement of the valves and passages, how the device may, with obvious modifications or additions, be used as a steam-engine, or, with no additions, be used as a pump. In describing it as a steam-engine it will be necessary to conceive of the addition of some ordinary mechanism for controlling the valves.

A is a short cylinder of large diameter, with swelled top and bottom, which may be thick

ly clothed on all sides to retain heat; and A' is a bed-plate, which supports all the parts. B is a strong, stiff piston, of such thickness as to leave room for but a short stroke. The piston-rod *b* is connected, by a wide knuckle-joint of many knuckles and a pin of small diameter, to a wide flat link, F, which is, in turn, connected, by a corresponding knuckle-joint, *f*, to the short arm of an unequal beam, D, the other end of which beam is connected, as usual, to a connecting-rod, G, which gives motion to a crank, H, of large throw, fixed on the main shaft I, which gives motion to the mechanism, and also through ordinary connections—not represented—to the valves of the engine, which may be of any ordinary or suitable character. These valves are represented here as simple hinged flaps, shutting onto inclined perforated seats. They may be worked by arms attached to the projecting ends of their shafts. The uprights A<sup>2</sup> of the framing support the double knife-edges, which carry the main center of the unequal beam D. These knife-edges are peculiar. The beam is cast in a single piece, of such thickness as to be almost perfectly rigid. Two knife-edges, *d*<sup>1</sup> *d*<sup>2</sup>, formed thereon at each side, rest in corresponding supports on the uprights A<sup>2</sup>, adapted to allow the proper rocking motion without friction. A wide space in between, exactly in line with these knife-edges, is recessed, as indicated, and receives a knife-edge, *e*, which is cast on the rigid binder E, which goes over the whole, and is secured by bolts, not represented. The beam D and the binder E may be cast with deep webs to make them very rigid. The uprights A<sup>2</sup> of the framing are connected by a transverse piece, so that the whole frame is as stiff as possible.

When, in the working of the machine, steam is admitted below the piston B the strain is thrown on the binder E, and as the crank H turns under the force transmitted the beam D rocks upon the knife-edge *e*. When, by the action of the valves, the steam is discharged below the piston and is admitted above, the strain due to the pressure on so large an area is received on the lower knife-edges *d*<sup>1</sup> *d*<sup>2</sup>, and the beam D rocks thereon, in both cases without friction. It will be understood that the knife-edges must be adjusted exactly in line with each other. The knuckle-joints *f*<sup>1</sup> *f*<sup>2</sup> being duplicated and extended widely, with narrow knuckles, as represented, allow the employment of so small a pin, on which the action turns, that the friction at these points involved in the transmission of a great force is very slight. The friction of a pin being as its di-

ameter, by making the pin of great length, comparatively, and supporting it at frequent intervals, as in this device, the friction of the pin is reduced to a minimum.

The law by which the saving in the loss by friction is governed is very simple, and it may be proper to lay it down here. The friction of a piston and cylinder, other things being equal, varies directly as the diameter of the cylinder. The capacity, and consequently the power, other things being equal, varies by a very different ratio, and is as the area of the piston—that is, as the square of its diameter. Hence, by increasing the diameter of a given piston and cylinder tenfold the force of the steam thereon becomes one hundred times greater, while the friction is only ten times greater than before; or, in other words, the friction is relatively to the power only one-tenth as great as before. This fact has long been known to many, and perhaps to most, engineers; but until my invention it has been incapable of utilization by reason of the great loss in the friction in the joints in the connections by which the motion is communicated. My invention allows the connections to be almost frictionless, and multiplies the small motion of the piston B, and makes it available on a light crank with large throw, so as to serve efficiently for very small engines and supply a want long felt and never yet fully met.

I claim as my invention—

1. The combination of the following elements: The cylinder A, and piston B of large diameter and short stroke, the unequal beam D, receiving the force from the piston on the short arm, the knife-edges *d*<sup>1</sup> *d*<sup>2</sup> to allow the motion of the beam D in one direction on a frictionless fulcrum, and the knife-edge *e* in a line with the knife-edges *d*<sup>1</sup> *d*<sup>2</sup> to allow the motion in the opposite direction, both motions being thus on nearly-frictionless fulcrums, all operating together as specified.

2. I also claim, in combination with the piston B of large diameter and short stroke and unequal beam D, the wide series of knuckles *f* of small diameter, adapted to support, by means of a pin of small diameter, a great force with little friction, as specified.

In testimony whereof I have hereunto set my hand in presence of two subscribing witnesses.

SAMUEL D. TILLMAN.

Witnesses:

A. HOERMANN,  
C. C. LIVINGS.